

HIGH AMPERAGE, SEALED/NON-SEALED, LOCKING/ NON-LOCKING POWER JACKS & PLUGS

NEW PRODUCT BULLETIN 599

SWITCHCRAFT®

A H E I C O C O M P A N Y



5555 N Elston Ave | Chicago, IL 60630 | P: 773.792.2700 | F: 773.792.2129 | www.switchcraft.com | Made in USA.

HIGH AMPERAGE, SEALED/NON-SEALED, LOCKING/ NON-LOCKING POWER JACKS & PLUGS

NEW PRODUCT BULLETIN 599



FEATURES & BENEFITS

- Up to 11A current rating (carry), 24 V DC
- -40°C to 105° C operating temperature
- Locking/Non-Locking versions available
- Automatic switch over from AC to DC permitted by sleeve shunt spring
- Available in sealed & non-sealed versions
- Sealed versions sealed to IP68, NEMA 250 (6P) (when mated)

APPLICATIONS

- Any sealed data transmission
- Military or industrial GPS location devices
- Instrumentation
- Medical equipment
- Marine Applications
- Transportation
- General industrial electronic applications
- Power supplies



Please visit switchcraft.com for the most up-to-date product specifications. Made in USA.

HIGH AMPERAGE, SEALED/NON-SEALED, LOCKING/ NON-LOCKING POWER JACKS & PLUGS

NEW PRODUCT BULLETIN 599

SPECIFICATIONS

Mechanical Specifications

Life:	5000 cycles minimum
Vibration:	Mil-Std 202G Method 201A (Locking Only)
Operating Forces:	5 lb maximum insertion. 0.5 lb minimum withdrawal
Panel Mounting Torque:	8-10 in-lb

Electrical Specifications

Voltage Rating:	24 V AC/DC
Current Rating:	Refer to current rating table
Insulation Resistance:	1000M Ω min
Contact Resistance (initial):	15 m Ω max

Environmental Specifications

Operating Temperature Rating:	-40 °C to +105 °C(-40°F to +221°F)
Moisture Resistance	MIL-STD 202G Method 106G (Sealed Only)
Insulation Resistance	MIL-STD 202G Method 302 Condition B
Thermal Shock:	MIL-STD 202G Method 107G
Salt Atmosphere (Corrosion):	MIL-STD 202G Method 101E Condition B (Sealed Only)
Weathertight Ratings:	IP66, IP67, IP68, NEMA 250 (6p) when mated (Sealed Only)

Material Specifications - Jacks

Housing, Cover (insulators):	Thermoplastic, Black
Mounting Bushing, Hex Nut:	Copper Alloy, Nickel Plated
Flat Washer:	Steel, Nickel Plated
O-Ring:	Elastomer, Black
Center Pin:	Copper Alloy, Nickel Plated
Center Pin Terminal & Shunt Terminals:	Copper Alloy, Silver or Matte Tin Plated
Sleeve Spring Terminal:	Spring Copper Alloy, Silver or Matte Tin Plated

Material Specifications - Plugs

Plug Barrel (Sleeve):	Copper Alloy, Nickel Plated
Coupling Ring:	Copper Alloy, Nickel Plated
Metal Handle:	Copper Alloy, Nickel Plated
Rubber Seal Handle:	Black Elastomer over Metal Handle
O-Ring:	Elastomer, Black
Center Contact (Tip):	Copper Alloy, Silver Plated
Tip & Sleeve Terminals:	Copper Alloy, Tin Plated
Tip Insulator:	Thermoplastic, Blue
Terminal Insulator:	Epoxy Glass FR4
Tubular Insulator:	Mylar



Please visit switchcraft.com for the most up-to-date product specifications. Made in USA.

HIGH AMPERAGE, SEALED/NON-SEALED, LOCKING/ NON-LOCKING POWER JACKS & PLUGS

NEW PRODUCT BULLETIN 599

PC-MOUNT HIGH AMERPAGE POWER JACKS

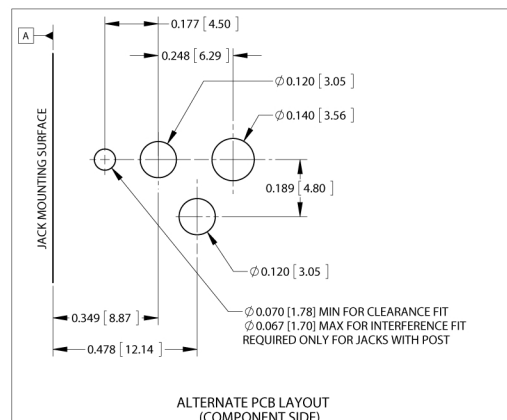
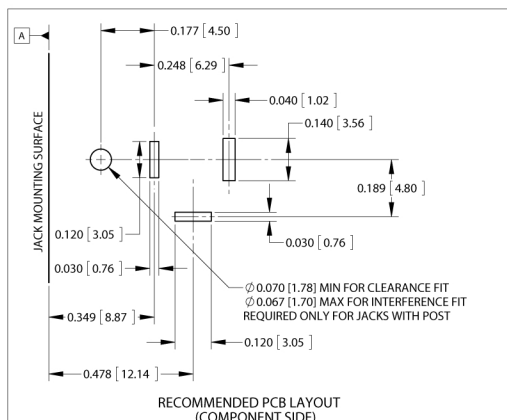
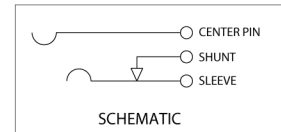
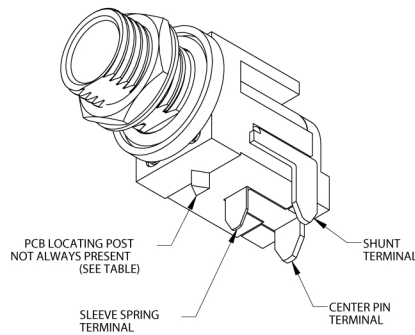
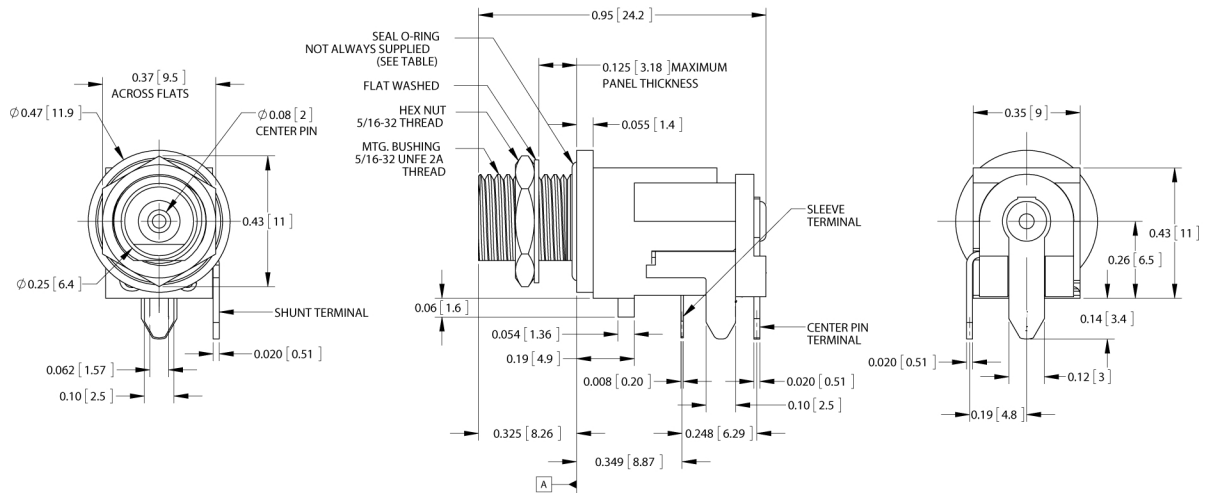

Please visit switchcraft.com for the most up-to-date product specifications. Made in USA.

HIGH AMPERAGE, SEALED/NON-SEALED, LOCKING/ NON-LOCKING POWER JACKS & PLUGS

NEW PRODUCT BULLETIN 599

SMT-MOUNT HIGH AMPERAGE POWER JACKS

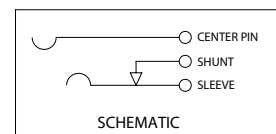
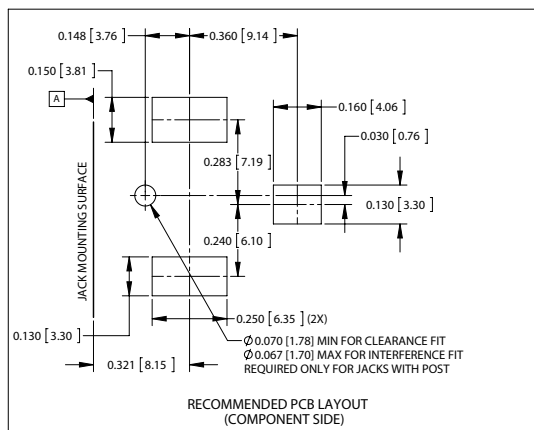
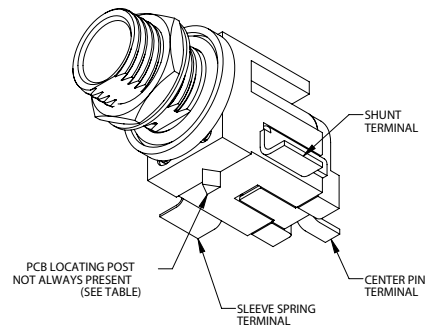
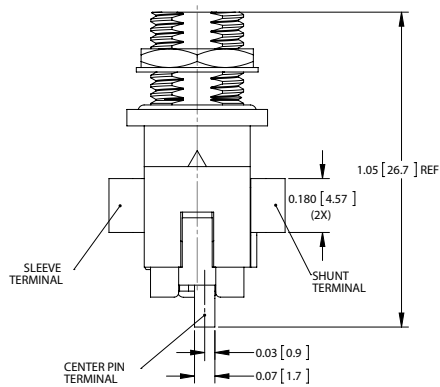
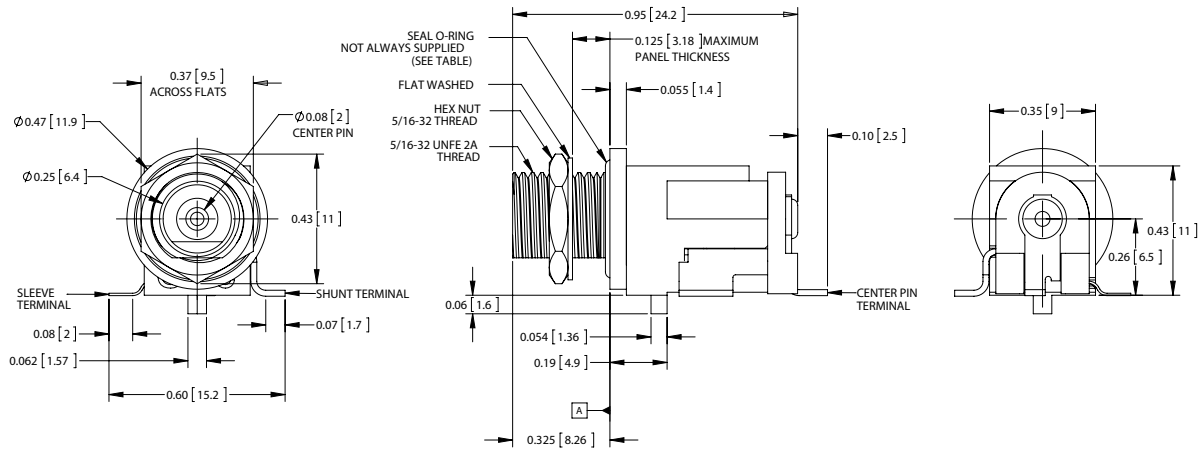

Please visit switchcraft.com for the most up-to-date product specifications. Made in USA.

HIGH AMPERAGE, SEALED/NON-SEALED, LOCKING/ NON-LOCKING POWER JACKS & PLUGS

NEW PRODUCT BULLETIN 599

HYBRID-MOUNT HIGH AMPERAGE POWER JACKS

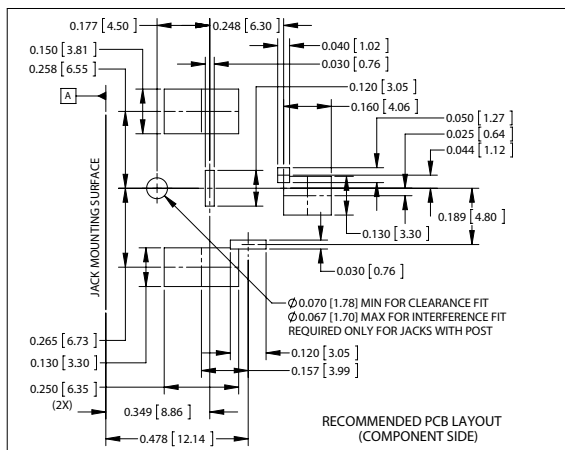
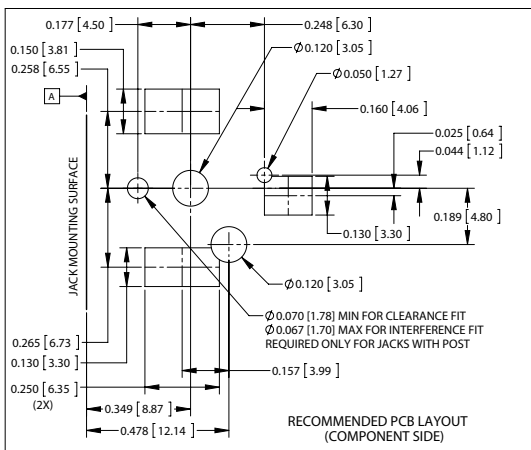
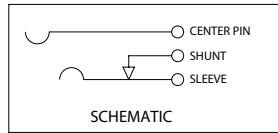
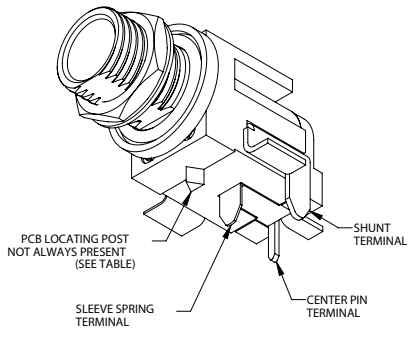
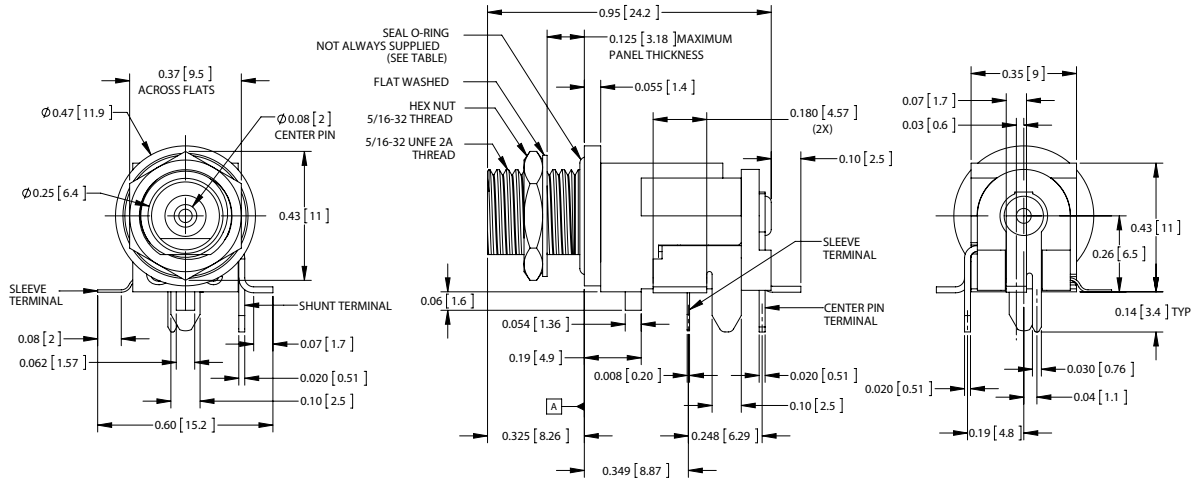

Please visit switchcraft.com for the most up-to-date product specifications. Made in USA.

HIGH AMPERAGE, SEALED/NON-SEALED, LOCKING/ NON-LOCKING POWER JACKS & PLUGS

NEW PRODUCT BULLETIN 599

LOCKING and SEALING PLUGS S10KS12, S10KS15, S10KS17

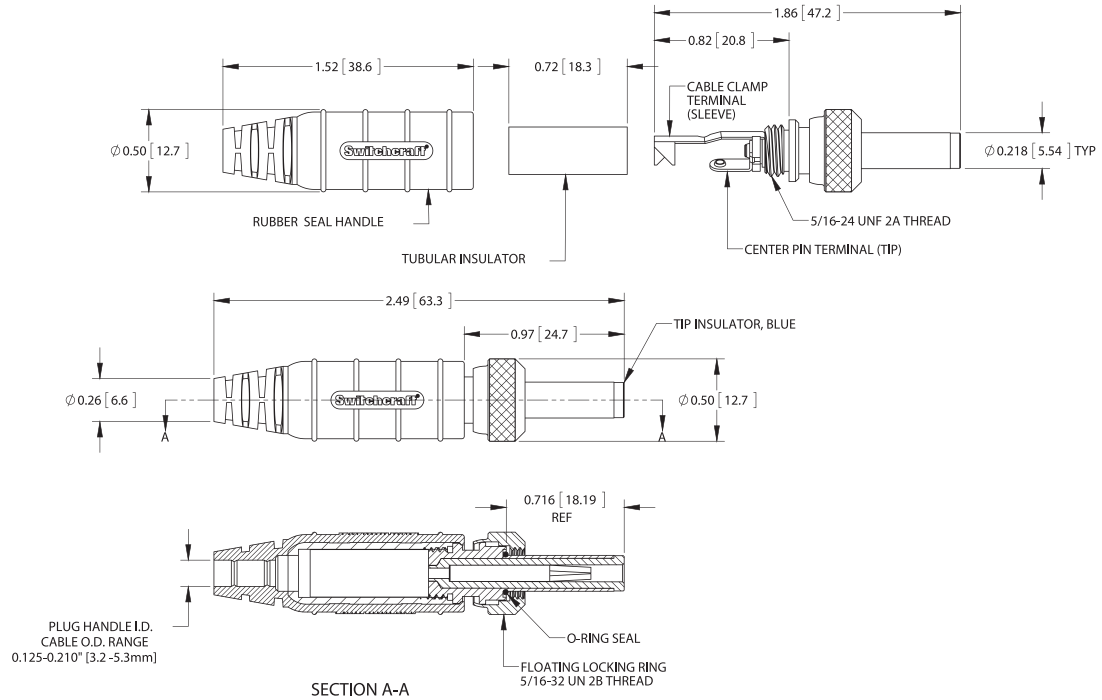

LOCKING, NON-SEALING PLUG S10K

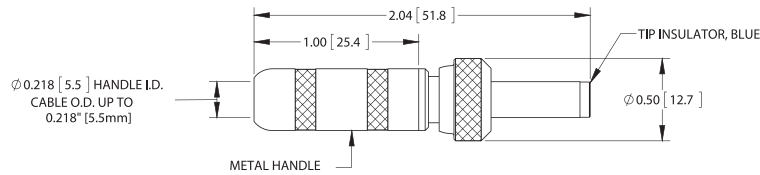

NON-LOCKING, NON-SEALING PLUGS S1012, S1015, S1017

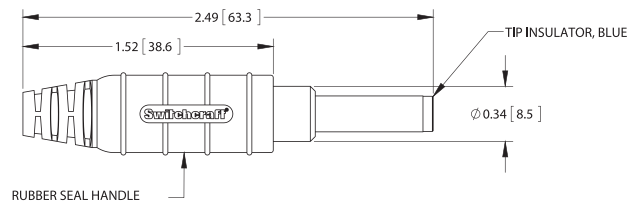

NON-LOCKING, NON-SEALING PLUG S10

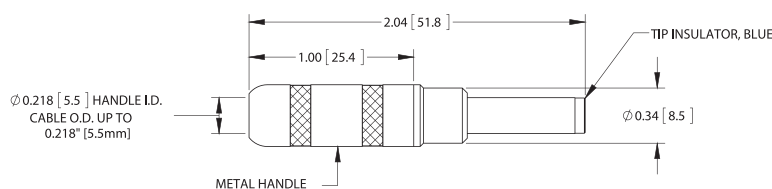

Please visit switchcraft.com for the most up-to-date product specifications. Made in USA.

HIGH AMPERAGE, SEALED/NON-SEALED, LOCKING/ NON-LOCKING POWER JACKS & PLUGS

NEW PRODUCT BULLETIN 599

CURRENT RATING TABLE

Jack Terminal Plating	Wire (awg)	Current Rating (A) at Operating Temperature (°C)					
		55°C max	65°C max	75°C max	85°C max	95°C max	105°C max
Silver	16	11	10	9.5	9	7.5	6
	18	9.5	9	8	7	5.5	5
	20	9	8	6.5	6	5	4
Tin	16	11	10	9	8	7	5.5
	18	9.5	9	8	7	5.5	5
	20	8.5	8	6.5	5.5	5	4

Note: DC Power Plugs & Jacks are for current carry only. Switching Power Jack on-off under resistive load is not recommended. The circuitry on-off switch should be off before connecting or disconnecting the Power Plug to Jack. For electrical life limitations under resistive load, consult factory.

HIGH AMPERAGE POWER PLUG ORDERING CODE:

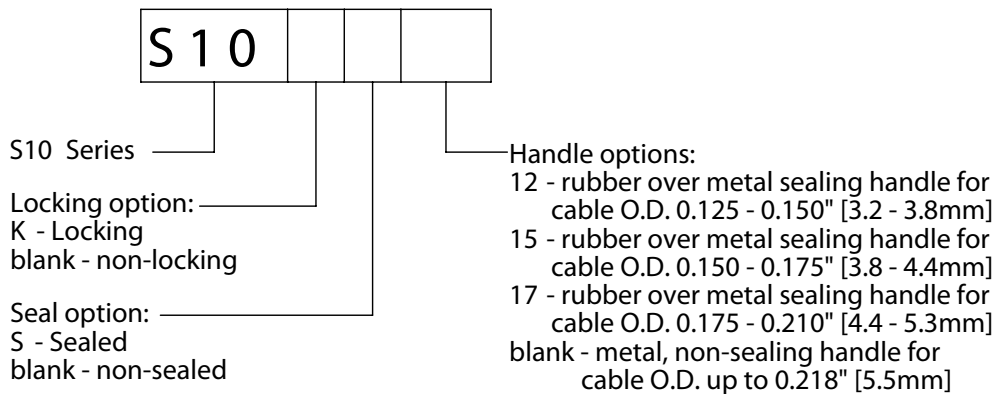

HIGH AMPERAGE POWER JACK ORDERING CODE:

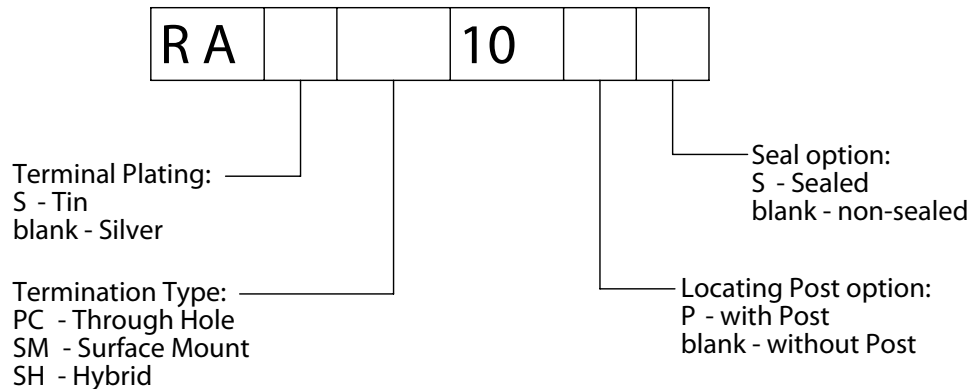

Notes:

- Standard packaging is bulk. Contact factory for tube or tape & reel packaging options.
- Tin plating currently not available for the hybrid (SH) termination option.



Please visit switchcraft.com for the most up-to-date product specifications. Made in USA.