

Type VF45&VF45(

RoHS

Slow Blow Square Ceramic Surface Mount Fuse



Electrical Characteristic

Cartridge Catalog Number	Ampere Rating [In]	Voltage Rating (V)	Nominal Resistance Cold Ohms	Nominal Melting I ² t A ² Sec
VF45GVF45I .100	100 mA	125V 86V	2.7860	0.028421
VF45GVF45I .125	125 mA		2.1360	0.032917
VF45GVF45I .160	160 mA		1.8886	0.054704
VF45GVF45I .200	200 mA		1.5743	0.061523
VF45GVF45I .250	250 mA		1.2553	0.068274
VF45GVF45I .300	300 mA		1.1475	0.090167
VF45GVF45I .350	350 mA		0.9277	0.105084
VF45GVF45I .375	375 mA		0.7247	0.215084
VF45GVF45I .400	400 mA		0.6902	0.246753
VF45GVF45I .450	450 mA		0.5005	0.304872
VF45GVF45I .500	500 mA		0.3283	0.385005
VF45GVF45I .700	700 mA		0.2673	0.482872
VF45GVF45I .750	750 mA		0.1601	0.633362
VF45GVF45I 001	1 A		0.1096	1.933045
VF45GVF45I 1.25	1.25 A		0.0874	3.278012
VF45GVF45I 1.50	1.5 A		0.0515	3.834080
VF45GVF45I 002	2 A		0.0451	8.548880
VF45GVF45I 2.50	2.5 A		0.0281	16.68000
VF45GVF45I 003	3 A		0.0216	23.25100
VF45GVF45I 3.50	3.5 A		0.0185	29.28420
VF45GVF45I 004	4 A		0.0141	36.06500
VF45GVF45I 005	5 A		0.0127	55.37600
VF45GVF45I 006	6 A		0.0088	64.67760
VF45GVF45I 007	7 A		0.0081	107.8320
VF45GVF45I 008	8 A		0.0075	134.5480
VF45GVF45I 010	10A		0.0068	172.4400
VF45GVF45I 012	12A		0.0061	251.6600
VF45GVF45I 015	15A		0.0055	301.1360
VF45GVF45I 018	18A		0.0042	415.8320
VF45GVF45I 020	20A		0.0035	447.8400
VF45GVF45I 025	25A	0.0026	530.8400	
VF45GVF45I 030	30A	0.0013	790.0000	

Approval

Recognized Component for Canada and U.S. 0.1~30A
TUV 0.1~12A(VF452/125V/86V)

Electrical Characteristic

Rated current	1 In		2 In		3 In		8 In	
	MIN	MIN	MAX	MIN	MAX	MIN	MAX	
100mA~12A	4hr	1 sec	60 sec	0.2 sec	3 sec	0.02 sec	0.1 sec	

Rated current	1 In	2 In
	MIN	MAX
15A~30A	4hr	60 sec

Environmental Temperature at 25°C

Interrupting Rating

100mA~15A: 100 amperes at 125VAC/DC (UL)
18A~30A: 50 amperes at 125VAC/DC
100mA~30A: 150 amperes at 86VAC (UL)
100mA~30A: 200 amperes at 86V DC (UL)
100mA~7A: 100 amperes at 125V AC/DC (TUV)
8A~12A: 50 amperes at 86V AC/DC (TUV)

Mechanical Dimension

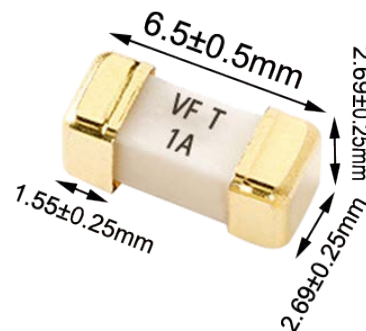

Physical Specification

Material

Body: Ceramic
Terminations: Gold plated brass caps(VF452)
Silver Plated Brass Caps(VF454)

Packaging

1,000 Fuses in 7 inches dia. reel, or 5,000 fuses in 13 inches dia. reel, 12mm wide tape, per EIA Standard 481

Environmental Specification

Operating Temperature

-55°C to +125°C

Vibration

MIL-STD-202G, Method 201 (10-55 Hz, 0.06 inch, total excursion)

Salt Spray

MIL-STD-202G, Method 101, Test Condition B (48Hrs)

Insulation Resistance

MIL-STD-202G, Method 302, Test Condition A (10,000 ohms minimum)

Resistance to Solder Heat

MIL-STD-202G, Method 210, Test Condition B (10sec, at 260°C)

Thermal Shock

MIL-STD-202G, Method 107, Test Condition B (-65°C to +125°C)

Temperature Derating Curve

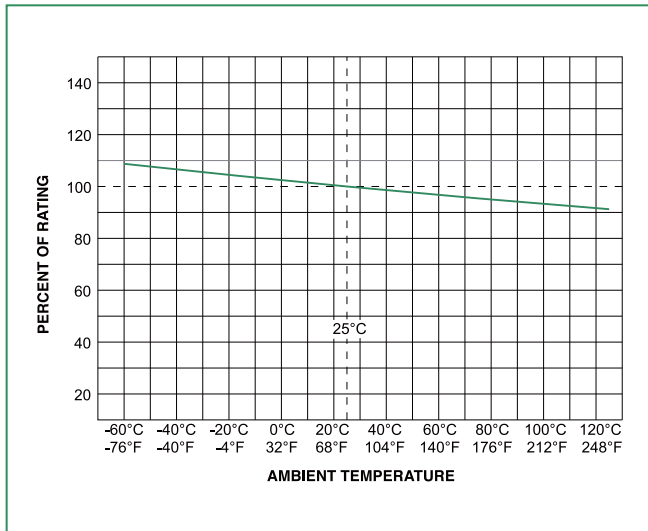

Note:
1. Derating depicted in this curve is in addition to the standard derating of 25% for continuous operation.

Average Time Current Curves

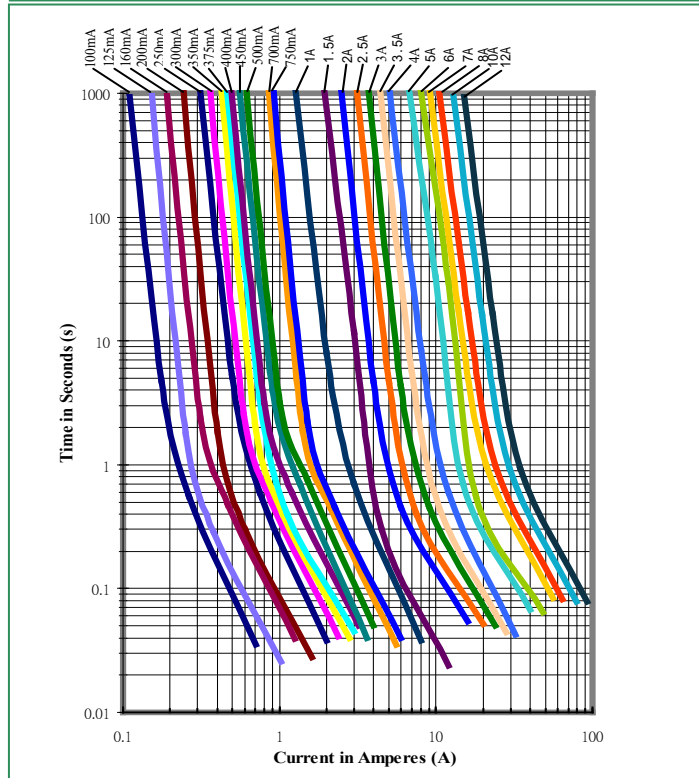

Soldering Parameters

Reflow Condition		Pb - Free assembly
Pre Heat	- Temperature Min ($T_{s(min)}$)	150°C
	- Temperature Max ($T_{s(max)}$)	200°C
	- Time (Min to Max) (t_s)	60 - 180 secs
Average ramp up rate (Liquidus Temp (T_L) to peak)		5°C/second max.
$T_{s(max)}$ to T_L - Ramp-up Rate		5°C/second max.
Reflow	- Temperature (T_L) (Liquidus)	217°C
	- Temperature (t_L)	60 - 150 seconds
Peak Temperature (T_p)		260 ^{+0/-5} °C
Time within 5°C of actual peak Temperature (t_p)		20 - 40 seconds
Ramp-down Rate		5°C/second max.
Time 25°C to peak Temperature (T_p)		8 minutes max.
Do not exceed		260°C
Wave Soldering Parameters	260°C Peak Temperature, 10 seconds max.	

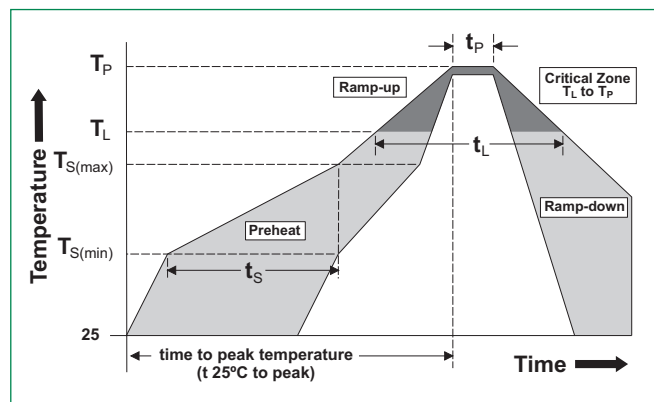

Hand Soldering: 350 ,3Sec.max.The tip of the soldering iron should not touch the copper fuse cap.

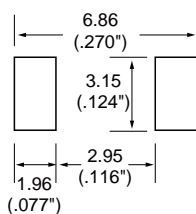

Recommended pad layout

With Fuse Block: 100mA~7A

Mechanical Dimension(mm)

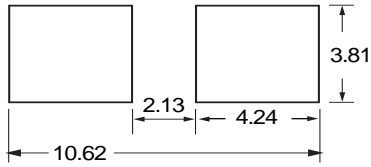

Recommended Pad Layout

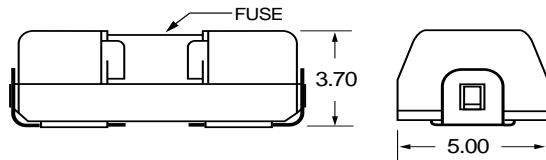
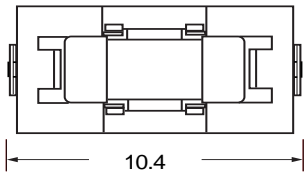

Part Numbering System

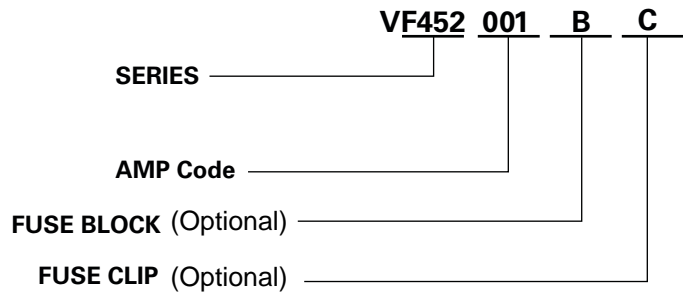

With Fuse Clip: 100mA~5A

Mechanical Dimension(mm)

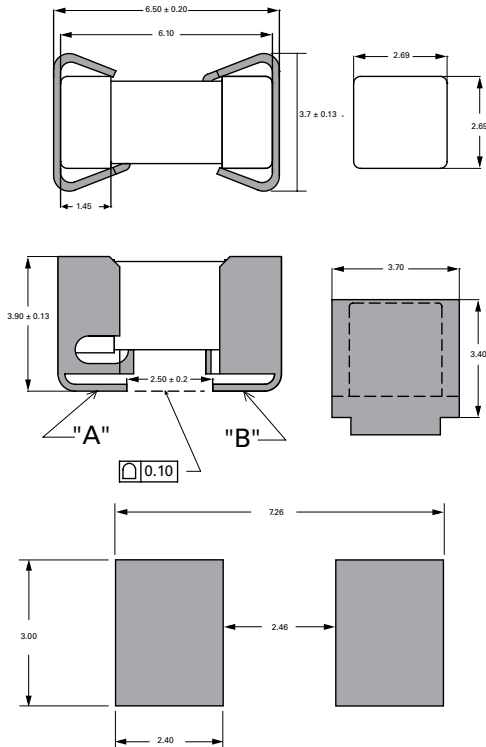

PCB Recommendation for Thermal Management

1. Minimum Copper Layer Thickness = 100um
2. Minimum Copper Trace Width = 10mm

Note:

Alternate methods of thermal management may be used. In such cases, under normal operations, the maximum temperature of the fuse body should not exceed 80°C in a 25°C ambient environment.