

**SERIES:** PHP1-M | **DESCRIPTION:** DC-DC CONVERTER

**FEATURES**

- up to 1 W isolated output
- surface mount package
- 1:1 input range
- single unregulated output
- 2,000 Vdc isolation voltage
- -40 to 100°C temperature range
- efficiency up to 76%
- UL/cUL certified



**MODEL**

MODEL	input voltage		output voltage	output current	output power	ripple & noise <sup>1</sup>	efficiency
	typ (Vdc)	range (Vdc)	(Vdc)	max (mA)	max (W)	max (mVp-p)	typ (%)
PHP1-S3-S5-M	3.3	2.97~3.63	5	200	1	100	75
PHP1-S5-S5-M	5	4.5~5.5	5	200	1	100	75
PHP1-S5-S12-M	5	4.5~5.5	12	84	1	100	76
PHP1-S5-S15-M	5	4.5~5.5	15	66	1	100	76
PHP1-S12-S5-M	12	10.8~13.2	5	200	1	100	73
PHP1-S15-S5-M	15	13.5~16.5	5	200	1	100	74

Notes: 1. At full load, nominal input, 20 MHz bandwidth oscilloscope, output terminated with a 0.1  $\mu$ F multilayer low ESR ceramic capacitor.  
2. All specifications measured at Ta=25°C, nominal input voltage, rated output load, and after warm up unless otherwise specified.

**PART NUMBER KEY**

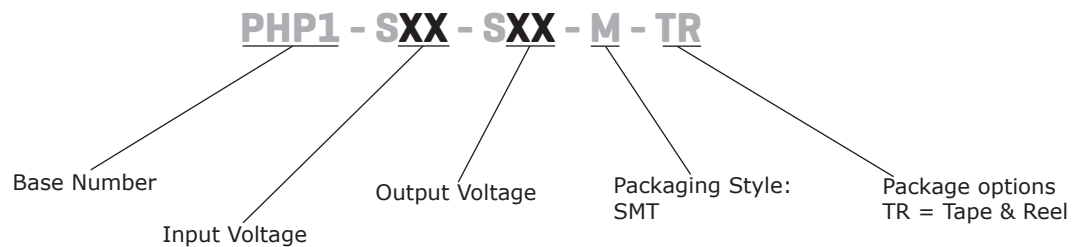

## INPUT

parameter	conditions/description	min	typ	max	units
operating input voltage	3.3 Vdc input model	2.97	3.3	3.63	Vdc
	5 Vdc input models	4.5	5	5.5	Vdc
	12 Vdc input model	10.8	12	13.2	Vdc
	15 Vdc input model	13.5	15	16.5	Vdc

## OUTPUT

parameter	conditions/description	min	typ	max	units
maximum capacitive load <sup>1</sup>	5 Vdc output models			1000	μF
	12 Vdc output model			330	μF
	15 Vdc output model			220	μF
voltage accuracy	at Vin nominal, full load, see tolerance envelope curves			±5	%
line regulation	measured from low to high line, full load		±1	±1.5	%
load regulation	measured from 20~100% load		±6	±10	%
switching frequency	at Vin nominal	20	60	100	kHz

Note: 1. Maximum capacitive load is defined as the capacitive load that will allow start up in under 1 second without damage.

## SAFETY AND COMPLIANCE

parameter	conditions/description	min	typ	max	units
isolation voltage	input to output for 1 second		2,000		Vdc
isolation resistance	at 500 Vdc	10,000			MΩ
isolation capacitance				75	pF
safety approvals	UL/cUL (60950-1, 2nd Edition)				
MTBF	as per MIL-HDBK-217F, full load, 25°C	2,992,000			hours
	as per MIL-HDBK-217F, full load, 85°C	955,000			hours
RoHS	yes				

## ENVIRONMENTAL

parameter	conditions/description	min	typ	max	units
operating temperature		-40		100	°C
storage temperature		-55		125	°C
operating humidity	non-condensing			95	%

## SOLDERABILITY

parameter	conditions/description	min	typ	max	units
reflow soldering <sup>2</sup>	see reflow solder profile			245	°C

Note: 2. In accordance with JEDEC STD-020C.

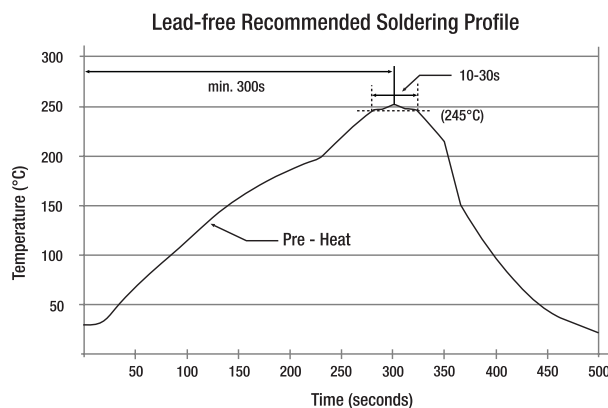

## MECHANICAL

parameter	conditions/description	min	typ	max	units
dimensions	12.75 x 10.7 x 7.0				mm
case material	non-conductive black plastic (UL94V-0)				
weight			1.0		g

## MECHANICAL DRAWING

units: mm  
 tolerance: XX.X = ±0.5 mm  
 XX.XX = ±0.25 mm

PIN CONNECTIONS	
PIN	Function
1	-Vin
2	+Vin
4	-Vout
5	+Vout
8	NC

NC = no connection

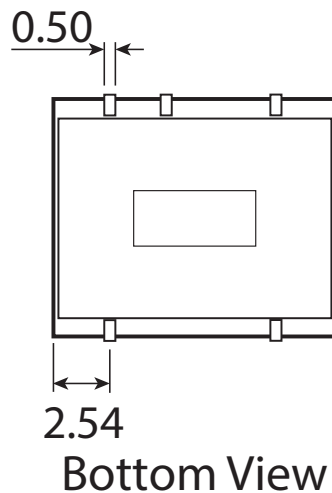
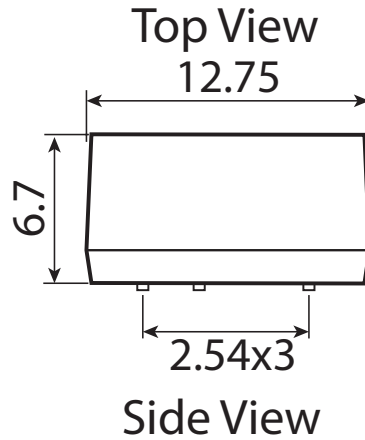
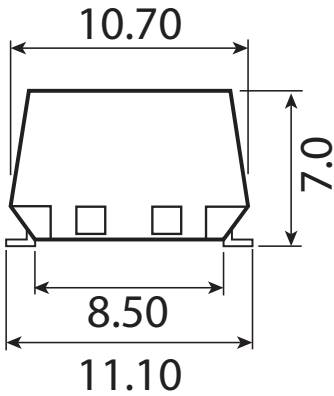
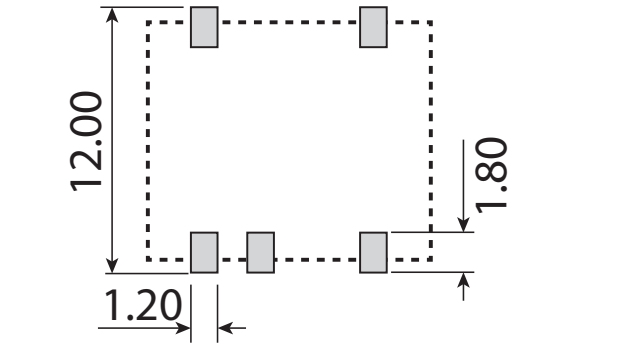
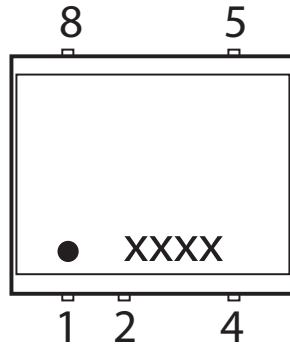

## PERFORMANCE CURVES

**OUTPUT REGULATION CURVE**  
(nominal input)

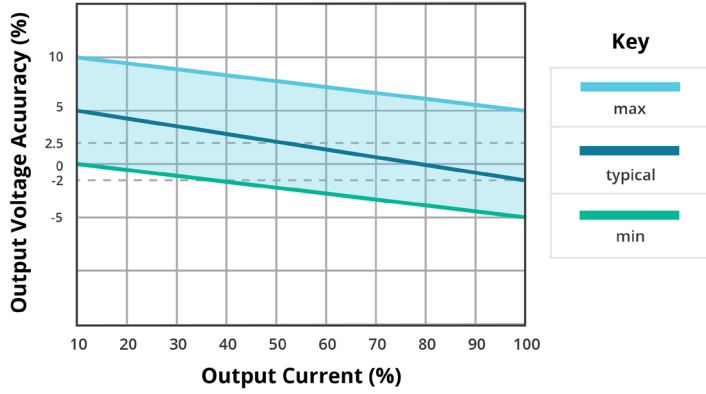

**EFFICIENCY VS OUTPUT LOAD**

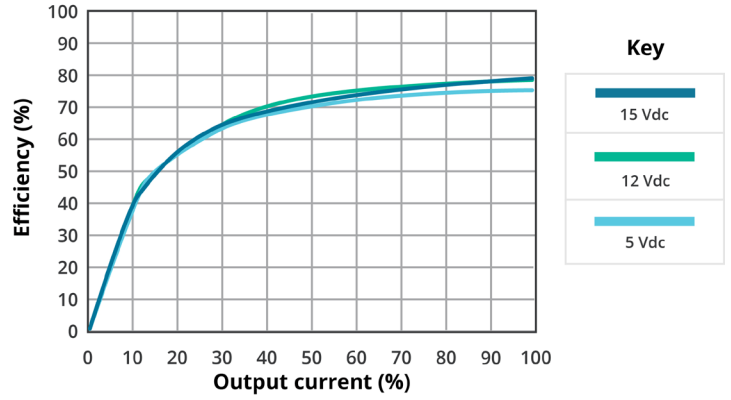

## PACKAGING

units: mm

Tape & Reel: Conforms to EIA-481-2  
 Reel Size: Ø13"  
 QTY: 500 pcs per reel

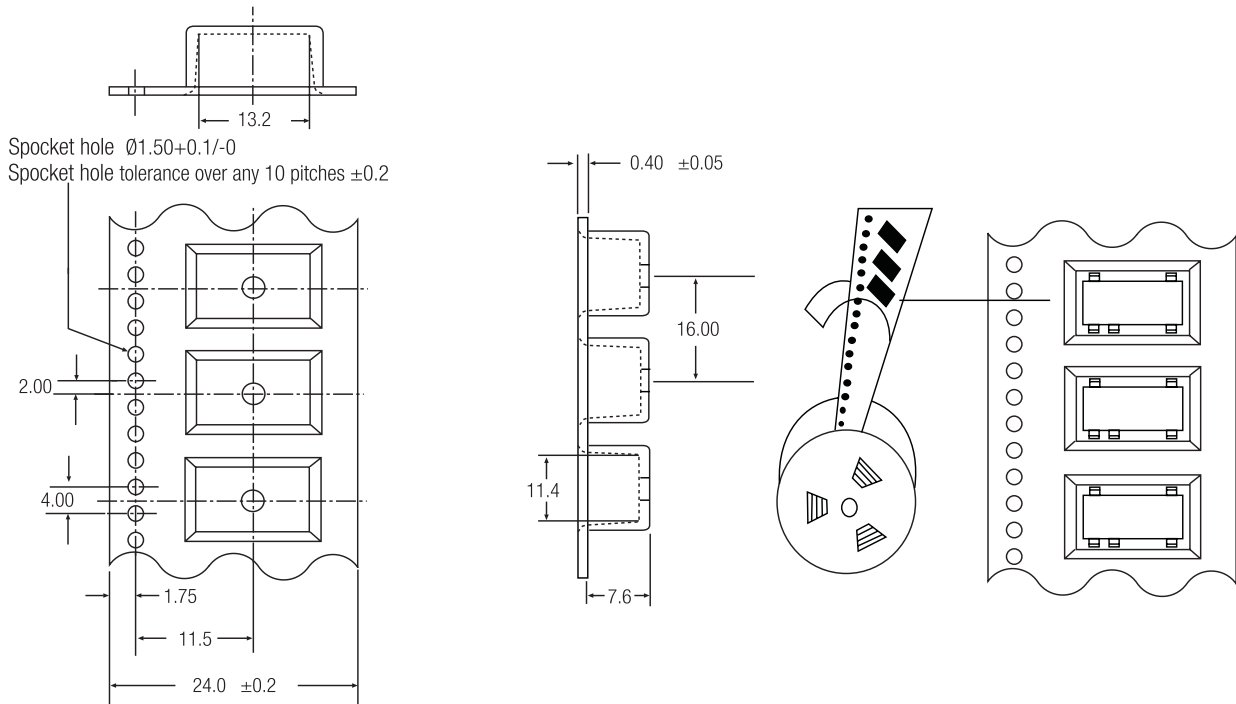

## REVISION HISTORY

rev.	description	date
1.0	initial release	07/25/2016
1.01	company logo updated	03/30/2021
1.02	performance curves updated	07/06/2021
1.03	packaging updated	06/13/2024
1.04	company address updated	11/05/2024
1.05	datasheet updated	04/24/2025

The revision history provided is for informational purposes only and is believed to be accurate.



# CUI INC

a bel group

**Headquarters**

15575 SW Sequoia Pkwy #100  
Portland, OR 97224  
**800.275.4899**

Fax 503.612.2383

**cui.com**  
techsupport@cui.com

CUI offers a two (2) year limited warranty. Complete warranty information is listed on our website.

CUI reserves the right to make changes to the product at any time without notice. Information provided by CUI is believed to be accurate and reliable. However, no responsibility is assumed by CUI for its use, nor for any infringements of patents or other rights of third parties which may result from its use.

CUI products are not authorized or warranted for use as critical components in equipment that requires an extremely high level of reliability. A critical component is any component of a life support device or system whose failure to perform can be reasonably expected to cause the failure of the life support device or system, or to affect its safety or effectiveness.

Please read our datasheet & drawing disclaimer [here](#).