

EMI Suppression Safety Capacitor, Ceramic Disc, Class X1, 760 V_{AC}, Class Y1, 500 V_{AC}

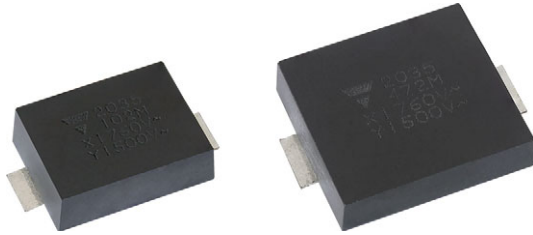

LINKS TO ADDITIONAL RESOURCES



QUICK REFERENCE DATA		
DESCRIPTION	VALUE	
Ceramic class	2	
Ceramic dielectric	Y5U	
Voltage (V _{AC})	500	760
Min. capacitance (pF)	470	
Max. capacitance (pF)	4700	
Mounting	Surface-mount (reflow soldering)	

OPERATING TEMPERATURE RANGE

-55 °C to +125 °C

TEMPERATURE CHARACTERISTICS

Y5U

SECTIONAL SPECIFICATIONS

Climatic category (according to EN 60058-1)
Class 2: 55 / 125 / 21

MOLDING

According to UL 94 V-0
Epoxy resin, isolating, flame retardant
Halogen-free
Reinforced insulation
Moisture sensitivity level: MSL 2a

APPROVALS

IEC 60384-14
UL 60384-14
DIN EN 60384-14
CSA E60384-1:14, CSA E60384-14:14
CQC11-471112-2015

FEATURES

- AEC-Q200 qualification planned for Q1/2025
- Complying with IEC 60384-14
- Humidity class IIB annex I achieved
- Singlelayer AC disc safety capacitors
- Mounting: surface-mount
- Material categorization:
for definitions of compliance please see
www.vishay.com/doc?99912



RoHS
COMPLIANT
HALOGEN
FREE

APPLICATIONS

- X1, Y1 according to IEC 60384-14
- Line-to-line filtering (Class X)
- Line-to-ground filtering (Class Y)
- Primary and secondary coupling (SMPS)
- Industrial and consumer
- EMI / RFI suppression and filtering

DESIGN

The capacitor consists of a ceramic disc which is copper plated on both sides. Encapsulation is made of flame retardant epoxy resin in accordance with UL 94 V-0.

CAPACITANCE RANGE

470 pF to 4700 pF

RATED VOLTAGE U_R

IEC 60384-14:

(X1): 760 V_{AC}, 50 Hz

(Y1): 500 V_{AC}, 50 Hz

Annex H: 1500 V_{DC}

TEST VOLTAGE

Component test (100 %):

4000 V_{AC}, 50 Hz, 2 s

Random sampling test (destructive test):

4000 V_{AC}, 50 Hz, 60 s

Voltage proof of molding (destructive test):

4000 V_{AC}, 50 Hz, 60 s

INSULATION RESISTANCE

≥ 10 000 MΩ

CAPACITANCE TOLERANCE

± 20 % (code M)

DISSIPATION FACTOR

Class 2: max. 2.5 % (1 kHz)



DIMENSIONS in millimeters

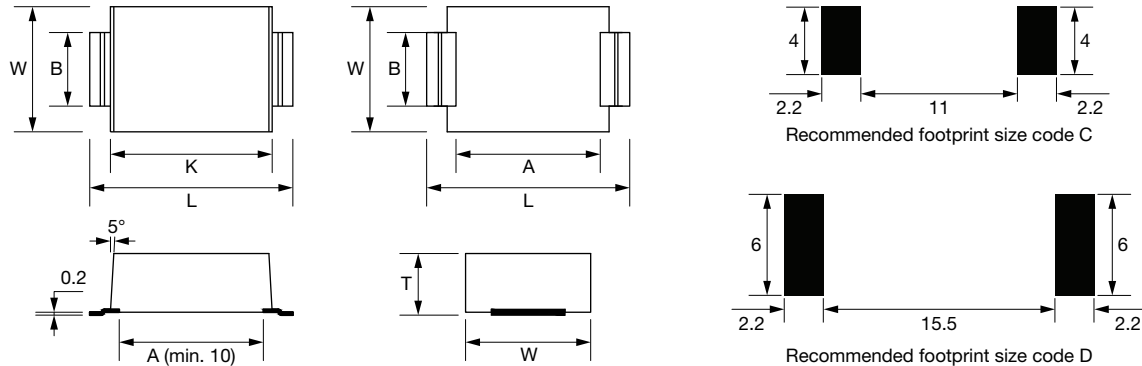

SIZE CODE	W (± 0.5)	L (± 0.5)	A (± 0.5)	B (± 0.5)	K (± 0.1)	T _{max.}
C	8.60	14.80	10.50	3.50	11.80	4.00
D	14.60	19.20	15.00	5.00	16.20	4.00

Note

- For soldering recommendation please see www.vishay.com/doc?28572

TECHNICAL DATA

CAPACITANCE (pF)	TOLERANCE (%)	SIZE CODE	PART NUMBER
			MISSING DIGITS SEE ORDERING CODE BELOW
Y5U			
470	± 20	C	SMDY1471MY5UC#
680		C	SMDY1681MY5UC#
1000		C	SMDY1102MY5UC#
1500		C	SMDY1152MY5UC#
2200		D	SMDY1222MY5UD#
3300		D	SMDY1332MY5UD#
3900		D	SMDY1392MY5UD#
4700		D	SMDY1472MY5UD#

ORDERING CODE

Example	SMDY1	472	M	Y5U	D	B
	Series	Capacitance value	Tolerance code	Temperature coefficient	Size code	Packaging code
						B = bulk R = tape and reel

PACKAGING

SIZE CODE	PACKAGING QUANTITIES	
	BULK	REEL
C	1000	1000
D	500	500

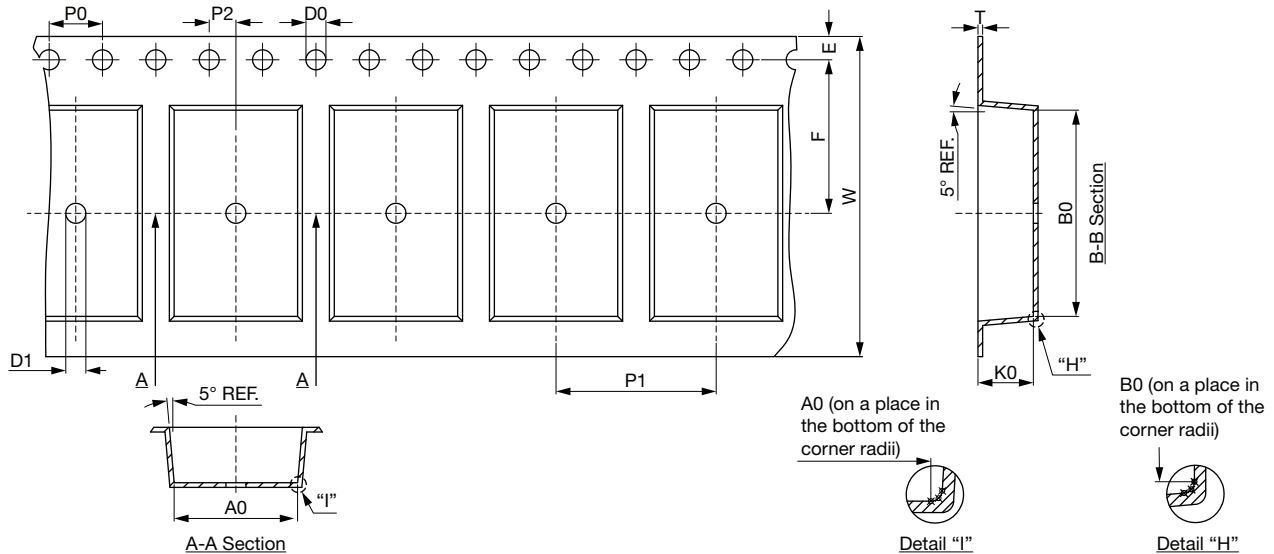
CARRIER TAPE DIMENSIONS FOR SIZE CODE C in millimeters

A0	B0	K0	P0	P1	P2	T	W	10 P0	E	F	D0	D1
9.25 ± 0.10	15.45 ± 0.10	4.15 ± 0.10	4.00 ± 0.10	12.00 ± 0.10	2.00 ± 0.10	0.35 ± 0.05	24.00 ± 0.30	40.00 ± 0.20	1.75 ± 0.10	11.50 ± 0.10	1.55 ± 0.05	1.5 min.

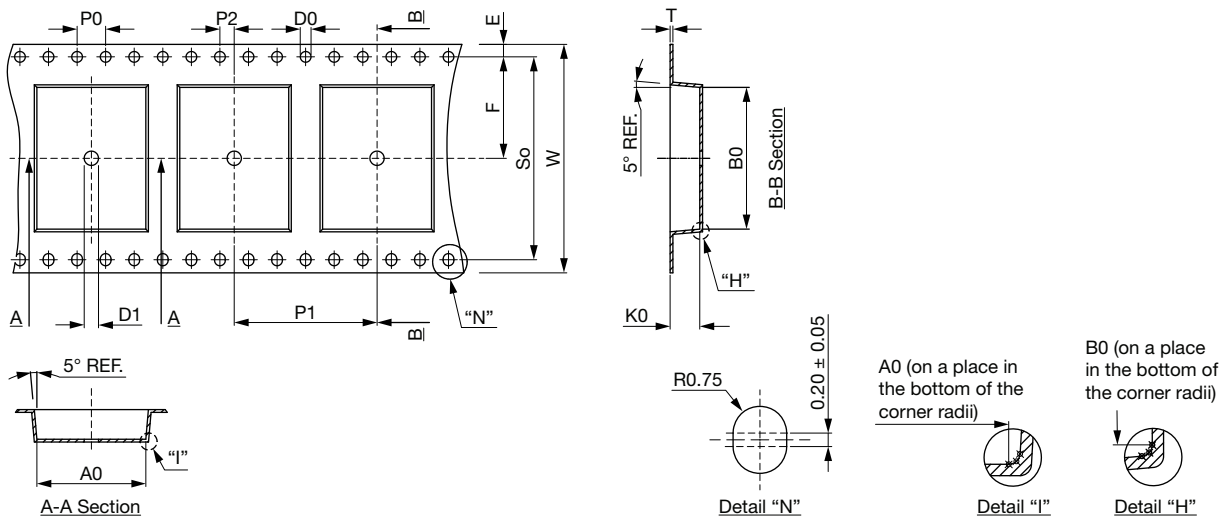
CARRIER TAPE DIMENSIONS FOR SIZE CODE D in millimeters

A0	B0	K0	P0	P1	P2	T	W	10 P0	So	E	F	D0	D1
15.25 ± 0.10	19.85 ± 0.10	4.15 ± 0.10	4.00 ± 0.10	20.00 ± 0.10	2.00 ± 0.10	0.35 ± 0.05	32.00 ± 0.30	40.00 ± 0.20	28.40 ± 0.10	1.75 ± 0.10	14.20 ± 0.10	1.50 + 0.10	2.0 min.

APPROVALS				
IEC 60384-14 - Safety tests This approval together with CB test certificate substitutes all national approvals.				
CB Certificate (www.vishay.com/doc?22268)				
Y1-capacitor: CB test certificate:	DE1-63889/A2	470 pF to 4.7 nF	500 V _{AC}	
X1-capacitor: CB test certificate:	DE1-63889/A2	470 pF to 4.7 nF	760 V _{AC}	
VDE (www.vishay.com/doc?22269)				
Y1-capacitor: VDE marks approval:	40052244	470 pF to 4.7 nF	500 V _{AC}	
X1-capacitor: VDE marks approval:	40052244	470 pF to 4.7 nF	760 V _{AC}	
DIN EN 60384-14 (VDE 0565-1-1):2014-04; EN 60384-14:2013-08				
DIN EN 60384-14/A1 (VDE 0565-1-1/A1):2017-04; EN 60384-14:2013/A1:2016				
Underwriters Laboratories Inc. / Canadian Standards Association (www.vishay.com/doc?22271)				
Y1-capacitor: CSA test certificate:	E183844	470 pF to 4.7 nF	500 V _{AC}	
X1-capacitor: CSA test certificate:	E183844	470 pF to 4.7 nF	760 V _{AC}	
UL 60384-14, CSA E60384-1:14, CSA E60384-14:14				
Fixed capacitors for electromagnetic interference suppression and connection to the supply mains.				
CQC (www.vishay.com/doc?22270)				
Y1-capacitor: CQC test certificate:	CQC20001274917	470 pF to 4.7 nF	500 V _{AC}	
X1-capacitor: CQC test certificate:	CQC20001274917	470 pF to 4.7 nF	760 V _{AC}	

MARKING	
<p>YY: year, ΔΔ: week, XXX: capacitance value, t: tolerance code ⁽¹⁾</p>	

Note

⁽¹⁾ Identify "XXX" and "t" by the ordering code

PERFORMANCE		
TEST	TEST CONDITION	TEST LIMITS
Visual and mechanical inspection	Optical inspection, dimensions measured with caliper	No visual damage, marking legible
Capacitance (C)	25 °C ± 3 °C; RH ≤ 75 %; 1.0 V _{RMS} ± 0.2 V _{RMS} at 1 kHz	Capacitance within specified tolerance
Dissipation factor (DF)		DF ≤ 2.5 %
Insulation resistance (IR)	Measured with 60 s ± 5 s after charging at 500 V _{DC}	Min. 10 000 MΩ
Dielectric strength	4000 V _{AC} at 50 Hz / 60 Hz for 1 min 50 mA max.	No failure
Solderability of termination	Immerse in solder bath for 2 s with 255 °C ± 5 °C after fluxing	95 % of the terminations are to be soldered
Impulse voltage	3 pulses of 8 kV	No failure

PERFORMANCE				
TEST	TEST CONDITION	TEST LIMITS		
Life test	125 °C; 1.5 kV _{AC} at 50 Hz; 1000 h 125 °C; 2250 V _{DC} ; 1000 h	No visual damage		
		$\Delta C/C < \pm 15\%$		
		DF $\leq 5\%$		
		IR $\geq 3000\text{ M}\Omega$		
		Dielectric strength: no failure		
Humidity test	500 h +48 h / -0 h; 40 °C \pm 2 °C; 90 % to 95 % RH; 760 V _{AC} at 50 Hz 500 h +48 h / -0 h; 40 °C \pm 2 °C; 90 % to 95 % RH; 1500 V _{DC}	No visual damage		
		$\Delta C/C < \pm 15\%$		
		DF $\leq 5\%$		
		IR $\geq 3000\text{ M}\Omega$		
		Dielectric strength: no failure		
		500 h +48 h / -0 h; 40 °C \pm 2 °C / 90 % to 95 % RH; 0 V loading	No visual damage	
	$\Delta C/C < \pm 15\%$			
	DF $\leq 5\%$			
	IR $\geq 3000\text{ M}\Omega$			
	Dielectric strength: no failure			
	500 h +48 h / -0 h; 85 °C \pm 3 °C / 85 % RH; 760 V _{AC} at 50 Hz 500 h +48 h / -0 h; 85 °C \pm 3 °C / 85 % RH; 1500 V _{DC}		No visual damage	
		$\Delta C/C < \pm 15\%$		
DF $\leq 5\%$				
IR $\geq 3000\text{ M}\Omega$				
Dielectric strength: no failure				
Robustness of termination		Shear test: 17.7 N for 10 s \pm 1 s for soldered on PCB		No damage to capacitor body and pin
	Bending test: 1 mm bending constant for 5 s \pm 1 s			
		Resistance to soldering heat (solder bath)	20 mm/s dipping speed; dwell 10 s at 2 mm dipping; 260 °C \pm 5 °C	
	$\Delta C/C < \pm 10\%$			
	DF $\leq 5\%$			
	IR $\geq 3000\text{ M}\Omega$			
	Dielectric strength: no failure			
	Temperature cycling	-55 °C to +125 °C; 5 cycles	No visual damage	
			$\Delta C/C < \pm 30\%$	
			DF $\leq 5\%$	
			IR $\geq 3000\text{ M}\Omega$	
			Dielectric strength: no failure	



PERFORMANCE		
TEST	TEST CONDITION	TEST LIMITS
Electrical characterization	25 °C and -40 °C, +125 °C	Capacitance within specified tolerance
		DF ≤ 2.5 %
		Min. 10 000 MΩ
Mechanical shock	Half-sine; 100 g/s; 6 ms; 3 shocks each of 6 orientation	No visual damage
		ΔC/C < ± 10 %
		DF ≤ 5 %
Vibration	5 g/s; 1.5 mm amplitude; 20 min; 12 cycles each of orientation; 10 Hz to 2000 Hz	IR ≥ 10 000 MΩ
		No visual damage
		ΔC/C < ± 10 %
		DF ≤ 5 %
		IR ≥ 10 000 MΩ

AC CURRENT VS. VOLTAGE (Typical)

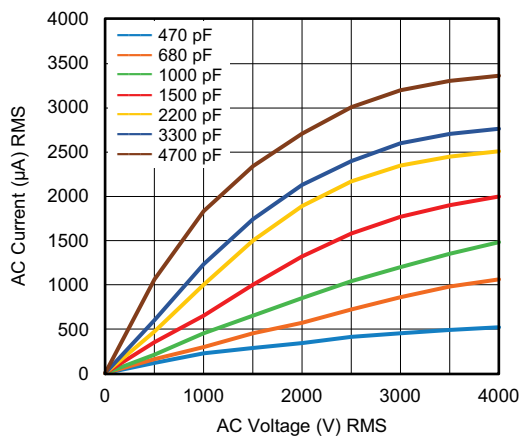

IMPEDANCE VS. FREQUENCY (Typical)

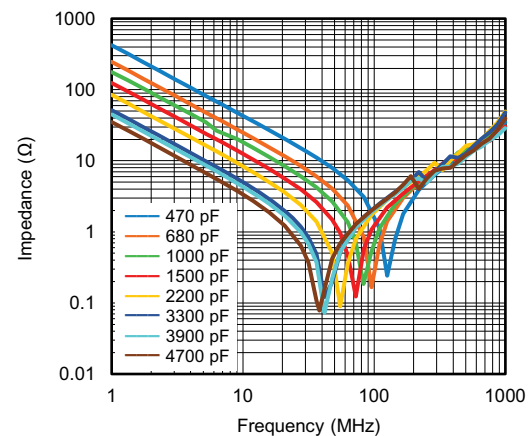

Note

- Unless stated otherwise all electrical values apply at an ambient temperature of 25 °C ± 3 °C, at normal atmospheric conditions

STORAGE AND OPERATION RECOMMENDATIONS

The molding resin of the molding type ceramic capacitor does not form a perfect seal, avoid corrosive gas and direct sunlight, and use (storage) in the condition without moisture condensation.

This series is declared to MSL 2a.

Solder the enclosed capacitors within 168 h after opening the moisture-proof package.

After opening, store it in the packing condition at the time of delivery or in a similar state.

Temperature: 10 °C to 30 °C

Humidity: 60 % max.

If it has been more than 4 weeks since opening, or if the 10 % display of the HIC (humidity indicator card) is pink, perform baking according to J-STD-033B0.1.

RELATED DOCUMENTS	
CB Test Certificate	www.vishay.com/doc?22268
VDE Marks Approval	www.vishay.com/doc?22269
UL Test Certificate	www.vishay.com/doc?22271
CQC Test Certificate	www.vishay.com/doc?22270
Soldering Recommendation	www.vishay.com/doc?28572



Disclaimer

ALL PRODUCT, PRODUCT SPECIFICATIONS AND DATA ARE SUBJECT TO CHANGE WITHOUT NOTICE TO IMPROVE RELIABILITY, FUNCTION OR DESIGN OR OTHERWISE.

Vishay Intertechnology, Inc., its affiliates, agents, and employees, and all persons acting on its or their behalf (collectively, "Vishay"), disclaim any and all liability for any errors, inaccuracies or incompleteness contained in any datasheet or in any other disclosure relating to any product.

Vishay makes no warranty, representation or guarantee regarding the suitability of the products for any particular purpose or the continuing production of any product. To the maximum extent permitted by applicable law, Vishay disclaims (i) any and all liability arising out of the application or use of any product, (ii) any and all liability, including without limitation special, consequential or incidental damages, and (iii) any and all implied warranties, including warranties of fitness for particular purpose, non-infringement and merchantability.

Statements regarding the suitability of products for certain types of applications are based on Vishay's knowledge of typical requirements that are often placed on Vishay products in generic applications. Such statements are not binding statements about the suitability of products for a particular application. It is the customer's responsibility to validate that a particular product with the properties described in the product specification is suitable for use in a particular application. Parameters provided in datasheets and / or specifications may vary in different applications and performance may vary over time. All operating parameters, including typical parameters, must be validated for each customer application by the customer's technical experts. Product specifications do not expand or otherwise modify Vishay's terms and conditions of purchase, including but not limited to the warranty expressed therein.

Hyperlinks included in this datasheet may direct users to third-party websites. These links are provided as a convenience and for informational purposes only. Inclusion of these hyperlinks does not constitute an endorsement or an approval by Vishay of any of the products, services or opinions of the corporation, organization or individual associated with the third-party website. Vishay disclaims any and all liability and bears no responsibility for the accuracy, legality or content of the third-party website or for that of subsequent links.

Vishay products are not designed for use in life-saving or life-sustaining applications or any application in which the failure of the Vishay product could result in personal injury or death unless specifically qualified in writing by Vishay. Customers using or selling Vishay products not expressly indicated for use in such applications do so at their own risk. Please contact authorized Vishay personnel to obtain written terms and conditions regarding products designed for such applications.

No license, express or implied, by estoppel or otherwise, to any intellectual property rights is granted by this document or by any conduct of Vishay. Product names and markings noted herein may be trademarks of their respective owners.