

| | | | | |
|-------------------------------------|----------------|------------------|--|------|
| Connector: SMA Jack (Female Socket) | | | | |
| Termination: PCB Surface Mount | | | | |
| Part Number | CON SMA001-SMD | CON SMA001-SMD-G | CON SMA001-SMD-G-T | |
| Packaging Type | Bulk | Bulk | Tape and Reel 400 Pieces per Reel 9 | |
| Connector Part | Material | Finish | | |
| Body | Brass | Nickel | Gold | Gold |
| Center Contact | Socket: BeCu | Gold | Gold | Gold |
| Insulator | PTFE | - | - | - |

| REVISIONS | | | |
|-----------|---|-----------|------|
| REV | DESCRIPTION | DATE | APPV |
| B | RECOMMENDED FOOTPRINT REVISED; GOLD & NICKEL FINISH OPTIONS | 9/25/09 | CJ |
| C | ADDED NEW TITLE BLOCK; UPDATED RECOMMENDED FOOTPRINT | 19-JUL-13 | BPM |
| D | ADDED DIMPLING TO PART; REMOVED FINISH OPTIONS | 3-JUN-13 | SAH |
| E | ADDED CONTACT TO STANDOFF DIMENSION; UPDATED NOTE 3 | 3-MAY-16 | SAH |
| F | UPDATED OUTER BARREL DIMENSION WAS Ø0.200 IS Ø0.212 | 29-NOV-17 | CLL |
| G | UPDATED DIMENSION UNITS; COMBINED GOLD AND NICKEL PLATED VERSIONS; ADDED SPECIFICATION SHEETS AND TAPE AND REEL VERSION | 1-OCT-19 | CLL |

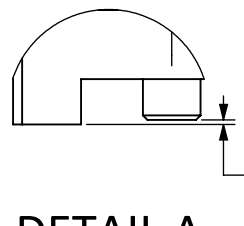

DETAIL A
SCALE 6 : 1

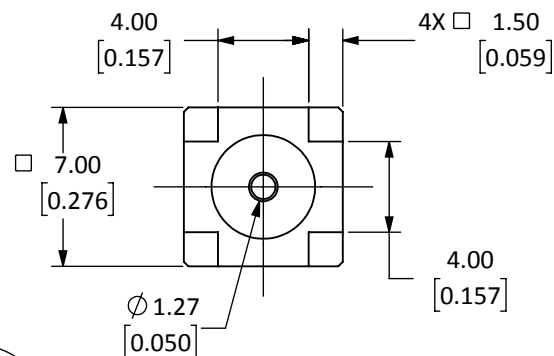
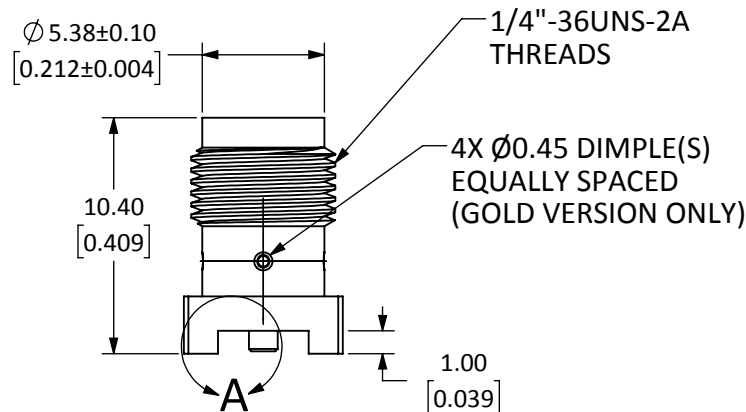
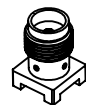

SCALE 1 : 1

NOTES: (UNLESS OTHERWISE SPECIFIED)

- ALL DIMENSIONS ARE IN MILLIMETERS [INCHES].
- DIMENSIONS APPLY AFTER FINISHING.
- MANUFACTURE TO BE COMPLIANT WITH EU RoHS DIRECTIVE, USE MATERIALS THAT DO NOT CONTAIN REACH SUBSTANCES OF VERY HIGH CONCERN >1000ppm, AND USE DRC CONFLICT-FREE SOURCED MATERIALS.
- SAFETY BREAK ALL SHARP CORNERS AND EDGES 0.5 MAXIMUM.
- SEE TABLE I FOR ELECTRICAL SPECIFICATIONS. (SHEET 2)
- SEE TABLE II FOR ENVIRONMENTAL SPECIFICATIONS. (SHEET 2)
- SEE TABLE III FOR MECHANICAL SPECIFICATIONS. (SHEET 2)
- SEE PARTSLIST. "*" INDICATE FINISH AND PACKAGING TYPE.
- PACKAGING INSTRUCTIONS (TAPE AND REEL VERSION ONLY):
 - APPLY LABEL, LBL-REEL-2.8x2.0, TO OUTSIDE OF REEL.
 - MARK LABEL WITH LINX PART NUMBER, MFG CODE, LINX PO NUMBER (LINX PO NUMBER IN LOT CODE FIELD) AND QUANTITY.
 - VACUUM PACK REEL WITH DESSICANT PACK (NO HIT CARD) INSIDE.
 - APPLY SECOND LINX LABEL, LBL-REEL-2.8x2.0, TO VACUUM SEALED BAG.
 - MARK SECOND LABEL WITH LINX PART NUMBER, MFG CODE, LINX PO NUMBER, (LINX PO NUMBER IN LOT CODE FIELD) AND QUANTITY

WARNING: THIS DRAWING CONTAINS PROPRIETARY INFORMATION THAT IS THE SOLE PROPERTY OF LINX TECHNOLOGIES, AND SHALL BE TREATED AS SUCH. NO DISCLOSURE OR REPRODUCTION OF THIS DOCUMENT IS PERMITTED, IN WHOLE OR IN PART, WITHOUT THE EXPRESS WRITTEN PERMISSION OF LINX TECHNOLOGIES OR ITS DESIGNATED AGENTS.

| | | |
|-----------|---|-------------------------------|
| MATERIAL: | TOLERANCES: 0.50 [0.020]-5.00 [0.200]= ±0.20 [0.008] 5.00 [0.200]-30.00 [1.200]= ±0.40 [0.016] 30.0 [1.200]-120.0 [4.75]= ±0.60 [0.24] 120.0 [4.75]-315.0 [12.40]= ±1.0 [0.040] | PROJECTION: |
| FINISH: | DRAWN: B.MURPHY ENGR: S.HOGAN | DT: 22-APR-13 DT: 3-JUN-13 |



TITLE:
**SMA FEMALE PCB MOUNT
SURFACE MOUNT**

| | | |
|------------|---------------------------|--------------|
| SIZE | DWG. NO. | REV |
| A | CON SMA001-SMD-*_* | G |
| SCALE: 3:1 | DO NOT SCALE DRAWING | SHEET 1 OF 3 |

5 TABLE I

| Electrical Data | Detail | |
|-----------------------|--|--|
| Part Number | CONSMA001-SMD | CONSMA001-SMD-G |
| Impedance | 50 Ω | 50 Ω |
| Frequency Range | 0 to 18 GHz | 0 to 18 GHz |
| Insulation Resistance | - | - |
| Voltage Rating | 750 V RMS | 1000 V RMS |
| Contact Resistance | Center: ≤ 2.0 m Ω Outer: ≤ 2.0 m Ω | Center: ≤ 2.0 m Ω Outer: ≤ 2.0 m Ω |
| VSWR | 1.2 Max @ 6 GHz | 1.3 Max @ 6 GHz |

6 TABLE II

| Environmental Data | Detail |
|--------------------------|---|
| Corrosion (Salt spray) | ASTM B-117 |
| Thermal Shock | MIL-STD-202 Method 107 test condition B |
| Vibration | MIL-STD-202 Method 204 test condition D |
| Mechanical Shock | MIL-STD-202 Method 213 test condition I |
| Temperature Range | -65 °C to +165 °C |
| Environmental Compliance | RoHS |

7 TABLE III

| Mechanical Data | Detail |
|------------------------|---|
| Mounting Type | Panel Mount, Surface Mount, Right Angle |
| Fastening Type | 1/4"-36 Threaded Coupling |
| Recommended Torque | 0.57 N·m (5.0 in·lbs) |
| Coupling Nut Retention | 60 lbs. min. |
| Connector Durability | 500 cycles min. |
| Weight | 1.5 g (0.05 oz) |

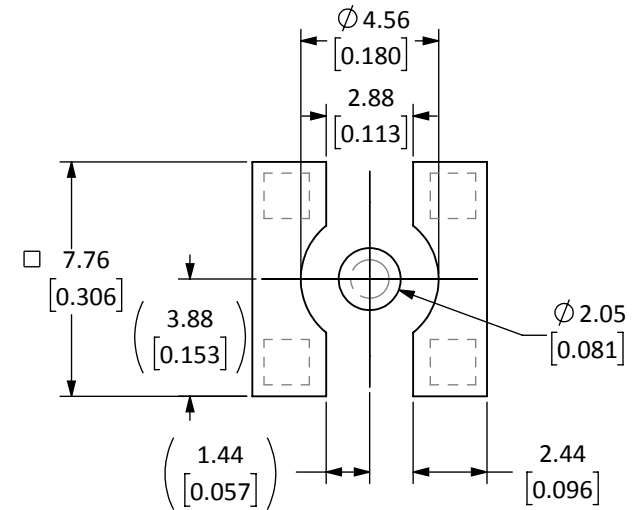

RECOMMENDED FOOTPRINT

| | | |
|------------|----------------------|--------------|
| SIZE | DWG. NO. | REV |
| A | CONSMA001-SMD-*-* | G |
| SCALE: 4:1 | DO NOT SCALE DRAWING | SHEET 2 OF 3 |

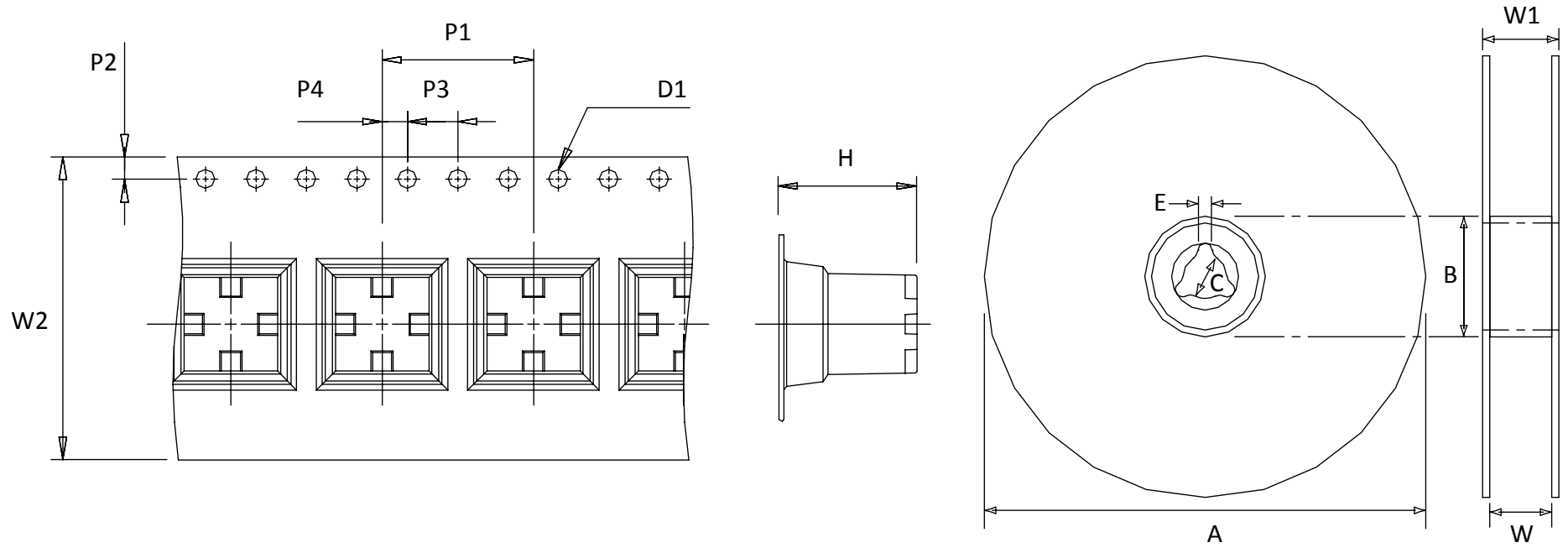

| TAPE DIMENSIONS | | |
|-----------------|----------------|-----------|
| SYMBOL | DIMENSION (mm) | TOLERANCE |
| D1 | Ø1.55 | ± 0.10 |
| H | 10.8 | ± 0.20 |
| P1 | 12.00 | ± 0.20 |
| P2 | 1.75 | ± 0.10 |
| P3 | 4.0 | ± 0.20 |
| P4 | 2.0 | ± 0.20 |
| W2 | 24.00 | ± 0.30 |

| REEL DIMENSIONS | | |
|-----------------|----------------|------------------|
| SYMBOL | DIMENSION (mm) | TOLERANCE |
| A | 330 | ± 1.50 |
| B | 100 | ± 1.00 |
| C | 13.3 | ± 0.30 |
| E | 2.5 | ± 0.30 |
| W | 24.5 | + 1.50 - 0.10 |
| W1 | 28.7 | ± 0.40 |

| | | |
|------------|----------------------|--------------|
| SIZE | DWG. NO. | REV |
| A | CON SMA001-SMD-**-* | G |
| SCALE: 4:1 | DO NOT SCALE DRAWING | SHEET 3 OF 3 |