

ASSEMBLY NUMBER	B +0.010 -0.005	C APPROX	D MAX	L MAX	M +0.010 +0.000	N DIA +0.001 -0.005	SS DIA +0.000 -0.016	CAP	DISK
10-101957-6	.125	3.000	.562	.754	.368	.348	.439	10-101958-6	10-150925-1
-8			.688			.473	.563	-8	-2
-10			.812			.590	.680	-10	-3
-12		3.500	.969			.750	.859	-12	-4
-14			1.094			.875	.984	-14	-5
-16			1.219			1.000	1.108	-16	-6
-18			1.344			1.125	1.233	-18	-7
-20		4.000	1.469	.817	.430	1.250	1.358	-20	-8
-22			1.594	.817	.430	1.375	1.483	-22	-9
-24	.140		1.719	.850	.463	1.500	1.610	-24	-10

REL NO. 32508-164		REVISIONS	
CHG NO.	SYM	DESCRIPTION	DATE APPROVED
45525-169	A4	REDRAWN WAS SAME SIZE; REVISED DATA	9-28-65 SLUZNIS
46810-9	A5	REV L MAX COL; CHG PICT (REM UNDERCUT)	1-16-67 CABLE
56815-5	A6	SEE CHANGE NOTICE 56815-5	8-4-75 Gaudin
	B	(CL II) ADD & REL-XX9 & DATA RLSE: 76500-22	2-7-85 Prescott
	C	ADD & RELEASE-XXX & DATA	6-17-88
	D	SEE CHANGE NOTICE 90851	10/1/62
97704	E	(CL II) ADDED AND RELEASE-XXX & DATA	8-18-65 DEMATTEO
A8362	F	(CL II) ADDED SUFFIX -XXY TO NOTES	4-13-11 JONES
C3030	G	SEE ECN	6/10/16 A.Prescott

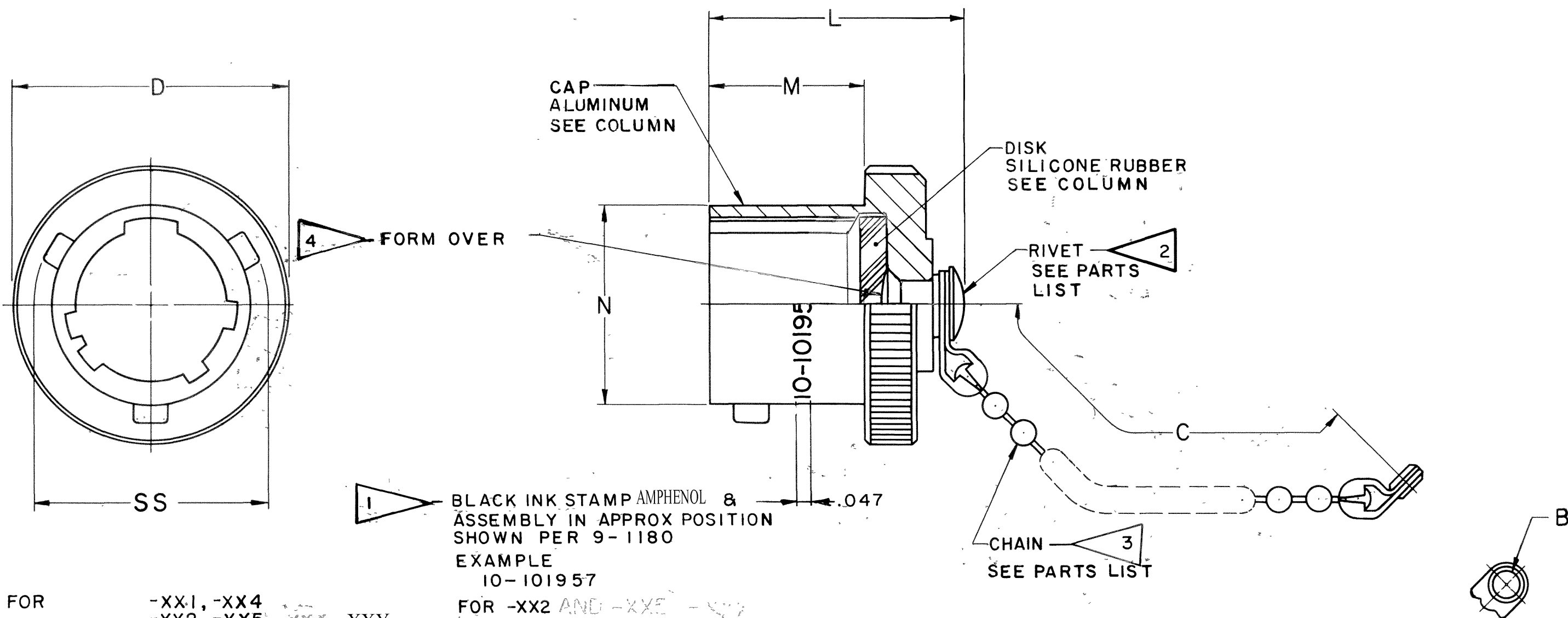

5. CAP TO BE USED WITH 72-127606/50 AND OTHERS

4. CHAIN MUST MOVE FREELY ON PROTECTIVE CAP AFTER ASSEMBLY.

3. CHAIN:
 MATERIAL BRASS
 FINISH: NICKEL PLATED FOR BLACK OXIDIZED
 OLIVE DRAB, CADMIUM PLATED
 MATERIAL STAINLESS STEEL
 FINISH: NONE FOR

2. RIVET:
 MATERIAL ALUMINUM ALLOY
 FINISH: BRIGHT CADMIUM PLATED FOR BLACK ANODIZED
 CADMIUM PLATE, OLIVE DRAB
 GREY ANODIZED
 CHROMATE TREATED
 STAINLESS STEEL

1. TO COMPLETE ASSEMBLY NUMBER AND CAP NO. ADD APPLICABLE LAST DIGIT SUFFIX FOR DESIRED FINISH.

CHROMATE TREATED	SUFFIX -XX0	BLACK ZINC CONDUCTIVE ALLOY PLATE	SUFFIX-XXX
BRIGHT CADMIUM PLATED	SUFFIX -XX1	BLACK ZINC COBALT PALTE	SUFFIX-XXY
BLACK ANODIZED	SUFFIX -XX2	GRAY ZINC NICKEL PLATE	SUFFIX -XXFL
CADMIUM PLATE, OLIVE DRAB	SUFFIX -XX3		
GREY ANODIZED	SUFFIX -XX4		
ANODIC COATED	SUFFIX -XX5		
OLIVE DRAB CADMIUM PLATE, NICKEL BASE PLATE	SUFFIX -XX9		
NICKEL ALLOY PLATE	SUFFIX -XX0		

BLACK INK STAMP AMPHENOL & ASSEMBLY IN APPROX POSITION SHOWN PER 9-1180
 EXAMPLE 10-101957
 FOR -XX2 AND -XX5
 WHITE INK STAMP PER 9-1180

USE OF THIS DOCUMENT IS UNLIMITED. DOCUMENTS REFERENCED HEREON CONTAIN LIMITED RIGHTS DATA.

ITEM NO.	QTY REQD	DESCRIPTION	PART NUMBER	CODE IDENT	ZONE	NEXT ASSEMBLY
PARTS LIST						
UNLESS OTHERWISE SPECIFIED		DRAWN: RINES	DATE: 3-29-57	AMPHENOL CORPORATION 40-60 DELAWARE AVENUE SIDNEY, NEW YORK		
LINEAR DIMENSIONS ARE IN INCHES. TOLERANCES: 3 PLACES ±.010; 2 PLACES ±.03, 1 PLACE ±.1; ANGLES ±2°. OTHER STANDARDS PER SCRITILLA SPEC. 9-3800 AND MIL-STD 8.		CHECKED: Testa	DATE: 1-2-65	TITLE: CAP, PROTECTIVE, PLUG, TYPE PT ()		
MATERIAL SPEC	PROCESS SPEC	STANDARDS: J. Balantine 11-4-65	DRAFTING: J. Amstutz 11-8-65	CODE IDENT NO	SIZE	
	9-1180	ENGINEERING:	DEVELOPMENT:	77820	C	10-101957
				SCALE NONE	WT	REF SHEET

NOTES: REF SYMBOL (CONTINUED TO RIGHT)

Mouser Electronics

Authorized Distributor

Click to View Pricing, Inventory, Delivery & Lifecycle Information:

Amphenol:

[10-101957-103](#) [10-101957-123](#) [10-101957-183](#) [10-101957-16FL](#) [10-101957-18FL](#) [10-101957-12FL](#) [10-101957-14FL](#) [10-101957-20FL](#) [10-101957-22FL](#)