

MIMX8QXnAVxFZAC
MIMX8DXnAVxFZAC

i.MX 8QuadXPlus and 8DualXPlus Automotive and Infotainment Applications Processors

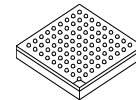

Package Information

21 x 21 mm package case outline
17 x 17 mm package case outline

Ordering Information

See [Section 1.1 Table 2 on page 5](#)

1 Introduction

This data sheet contains specifications for the i.MX 8QuadXPlus and 8DualXPlus processors, which, along with the i.MX 8DualX processor, comprise the i.MX 8X Family (for i.MX 8DualX specifications, see *i.MX 8DualX Automotive and Infotainment Processors* [IMX8DXAEC]). The i.MX 8X processors consist of three to five Arm cores (two to four Arm Cortex[®]-A35 and one Cortex[®]-M4F). All devices include separate GPU and VPU subsystems as well as a failover-ready display controller. Advanced multicore audio processing is supported by the Arm cores and a high performance Tensilica[®] HiFi 4 DSP for pre- and post-audio processing as well as voice recognition. The i.MX 8X Family supports up to three displays with multiple display output options, including parallel, MIPI-DSI, and LVDS. Memory interfaces for this device include:

- LPDDR4 (no error correcting code [ECC])
- DDR3L (optional ECC)
- 2× Quad SPI or 1× Octal SPI (FlexSPI)
- eMMC 5.1, RAW NAND, and SD 3.0

| | | |
|------|--|-----|
| 1 | Introduction | 1 |
| 1.1 | Ordering Information | 5 |
| 1.2 | System Controller Firmware (SCFW) Requirements | 6 |
| 1.3 | Package options | 7 |
| 1.4 | Related resources | 7 |
| 2 | Architectural Overview | 8 |
| 2.1 | Block Diagram | 9 |
| 3 | Modules List | 10 |
| 3.1 | Special Signal Considerations | 16 |
| 3.2 | Recommended Connections for Unused Interfaces | 16 |
| 4 | Electrical characteristics | 17 |
| 4.1 | Chip-level conditions | 17 |
| 4.2 | Power supplies requirements and restrictions | 27 |
| 4.3 | PLL electrical characteristics | 30 |
| 4.4 | On-chip oscillators | 33 |
| 4.5 | I/O DC Parameters | 36 |
| 4.6 | I/O AC Parameters | 43 |
| 4.7 | Output Buffer Impedance Parameters | 45 |
| 4.8 | System Modules Timing | 50 |
| 4.9 | General-Purpose Media Interface (GPMI) Timing | 54 |
| 4.10 | External Peripheral Interface Parameters | 63 |
| 4.11 | Analog-to-digital converter (ADC) | 111 |
| 5 | Boot mode configuration | 114 |
| 5.1 | Boot mode configuration pins | 114 |
| 5.2 | Boot devices interfaces allocation | 114 |
| 6 | Package information and contact assignments | 116 |
| 6.1 | FCPBGA, 21 x 21 mm, 0.8 mm pitch | 116 |
| 6.2 | FCPBGA, 17 x 17 mm, 0.8 mm pitch | 133 |
| 7 | Release Notes | 150 |

NXP reserves the right to change the detail specifications as may be required to permit improvements in the design of its products.



Introduction

A wide range of peripheral I/Os such as CAN, parallel or MIPI CSI camera input, Gigabit Ethernet, USB 2.0 OTG, USB 3.0 (8QuadXPlus/8DualXPlus only), ADC, and PCIe 3.0 provide impressive flexibility.

The i.MX 8QuadXPlus/8DualXPlus processors offer numerous advanced features as shown in this table.

Table 1. i.MX 8QuadXPlus/8DualXPlus advanced features

| Function | Feature |
|--|---|
| Multicore architecture provides 2×–4× Cortex-A35 and 1× Cortex-M4F cores | AArch64 for 64-bit support and new architectural features |
| | AArch32 for full backward compatibility with ARMv7 |
| | Cortex-A35 cores support ARM virtualization extensions. |
| | Cortex-M4F cores for real-time applications |
| Graphics Processing Unit (GPU) | 4× Vec4 shaders with 16 execution units optimized for higher performance |
| | Supports OpenGL 3.0, 2.1,; OpenGL ES 3.1, 3.0, 2.0, and 1.1; OpenCL 1.2 Full Profile and 1.1; OpenVG 1.1; and Vulkan |
| | High-performance 2D Blit Engine |
| Video Processing Unit (VPU) | H.265 decode (4Kp30) |
| | H.264 decode (4Kp30) |
| | WMV9/VC-1 imple decode |
| | MPEG 1 and 2 decode |
| | AVS decode |
| | MPEG4.2 ASP, H.263, Sorenson Spark decode |
| | Divx 3.11 including GMC decode |
| | ON2/Google VP6/VP8 decode |
| | RealVideo 8/9/10 decode |
| | JPEG and MJPEG decode |
| | H.264 encode (1080p30) |
| Tensilica HiFi 4 DSP for pre- and post-processing | 640 MHz Fixed-point and vector-floating-point support 32 KB instruction cache, 48 KB data cache, 512 KB SRAM (448 KB of OGRAM and 64 KB of TCM) |

Table 1. i.MX 8QuadXPlus/8DualXPlus advanced features (continued)

| Function | Feature |
|----------------------|--|
| Memory | 32-bit LPDDR4 @1200 MHz 40-bit DDR3L @933 MHz (ECC option) |
| | 1× Quad SPI which can be used to connect to an FPGA |
| | 2× Quad SPI or 1× Octal SPI (FlexSPI) for fast boot from SPI NOR flash |
| | 2× SD 3.0 card interfaces (note: if eMMC is used, then 1× SD 3.0 available in IOMUX) |
| | 1× eMMC5.1/SD3.0 (note: use of eMMC will restrict SD card availability to 1× SD 3.0 due to IOMUX restrictions) |
| | RAW NAND (62-bit ECC support via BCH-62 module) |
| Display Controller | Supports up to 3 independent displays (2× MIPI or LVDS + 1× Parallel) |
| | Up to 18-layer composition |
| | Complementary 2D blitting engines and online warping functionality |
| | Integrated Failover Path (SafeAssure) to ensure display content stays valid even in event of a software failure |
| Display I/O | Two MIPI-DSI/LVDS Combo PHYs (each up to 1080p60): Each single PHY can either be a 4-lane MIPI-DSI or a 4-lane channel LVDS interface for a total of 2 display interfaces. In combination, the two PHYs can be configured to be a single dual-channel LVDS interface. 1× 24-bit parallel LCD up to 720p60 (DDR bandwidth might limit the available resolution). |
| Camera I/O and video | 1× MIPI-CSI with 4-lanes |
| | 1× 8-bit/10-bit parallel CSI |
| Security | Advanced High Assurance Boot (AHAB) secure & encrypted boot |
| | Random Number Generator with a high-quality entropy source generator and Hash_DRBG (based on hash functions) |
| | RSA up to 4096, Elliptic Curve up to 1023 |
| | AES-128/192/256, DES, 3DES, MD5, SHA-1, SHA-224/256/384/512 |
| | Dedicated Security Controller for Flashless SHE and HSM support, Trustzone, RTIC |
| | Built-in ECDSA/DSA protocol support |
| | See the security reference manual for this chip for a full list of security features. |
| | 10× tamper pins (up to 5 active or 10 passive) |
| | Voltage and Temperature tamper detection |
| | 64 kB Secure RAM (can be erased via tamper detection) |
| System Control | <ul style="list-style-type: none"> • 2× I²C tightly coupled with Cortex-M4 cores (1× per Cortex M4F core) <ul style="list-style-type: none"> • The tightly coupled M4 I²C ports cannot be used for general-purpose use • System Control Unit (SCU): <ul style="list-style-type: none"> • Power control, clocks, reset • Boot ROMs • PMIC interface • Resource Domain Controller |

Table 1. i.MX 8QuadXPlus/8DualXPlus advanced features (continued)

| Function | Feature |
|-----------|--|
| I/O | 1× PCIe 3.0 (1-lane) with L1 substate support |
| | 1× USBOTG 3.0 with PHY—USB 3.0 can be used as USB 2.0 |
| | 1× USBOTG 2.0 (with PHY) |
| | 2× 1Gb Ethernet with AVB (can be used as 10/100 Mbps ENET with AVB) |
| | 3× CAN/CAN-FD Note: Legacy CAN mode supports both Mailbox (MB) and RX FIFO (with DMA support) operation. Flexible Data (FD) mode supports MB operation only. There is no enhanced RX FIFO or DMA support in FD mode. |
| | 1× Media Local Bus (MLB25/50) |
| | 6× UARTs: <ul style="list-style-type: none"> • 4× UARTs (3× with hardware flow control) • 1× UART tightly coupled with Cortex-M4F cores • 1× SCU UART (Note: SCU UART is dedicated to the SCU and not available for general use) |
| | 10× I ² C (note that there are two types of I ² C: High-speed I ² C ports with DMA support, and low-speed I ² C ports with no DMA support, which are used in conjunction with a specific PHY interface—for example, for touchscreen): <ul style="list-style-type: none"> • 4× I2C: High Speed, DMA support • 4× I2C: Low Speed, no DMA support • 1× I2C: PMIC control (dedicated) • 1× I2C: Cortex M4F (dedicated) Note: I2C ports associated with a PHY (e.g. MIPI DSI) can be used generally but require the PHY to be powered on even if the PHY interface itself is not used. |
| | 4× SAI (SAI0 and SAI1 are transmit/receive; SAI2 and SAI3 are receive only) |
| | 1× Enhanced Serial Audio Interface (ESAI) |
| | 2× ASRC (Asynchronous Sample Rate Converter) (note: no I/O signals are directly connected to this module) |
| | 1× SPDIF (Tx and Rx) |
| | 1× 6-channel ADC converter |
| | 3.3 V/1.8 V GPIO |
| | 4× PWM channels |
| | 1× 6×8 KPP (Key Pad Port) |
| | 1× MQS (Medium Quality Sound) |
| 4× SPI | |
| Packaging | Case FCPBGA 21 x 21 mm, 0.8 mm pitch |
| | Case FCPBGA 17 x 17 mm, 0.8 mm pitch |

1.1 Ordering Information

For ordering information, contact an NXP representative at nxp.com.

Table 2. i.MX 8QuadXPlus Orderable part numbers

| Part Number | Options | Cortex-A35 Speed Grade | Cortex-M4F Speed Grade | Temperature Grade | Package |
|-----------------|--|------------------------|------------------------|-------------------|--|
| MiMX8QX6AVLFZAC | With GPU, VPU, DSP, 24-bit Parallel LCD | 1.2 GHz | 264 MHz | Automotive | 21 mm X 21 mm, 0.8 mm pitch, FCPBGA (lidded) |
| MiMX8QX5AVLFZAC | With GPU, VPU, 24-bit Parallel LCD | 1.2 GHz | 264 MHz | Automotive | 21 mm X 21 mm, 0.8 mm pitch, FCPBGA (lidded) |
| MiMX8QX2AVLFZAC | With DSP. Features not supported: GPU, Display Controller, VPU, 24-bit Parallel LCD | 1.2 GHz | 264 MHz | Automotive | 21 mm X 21 mm, 0.8 mm pitch, FCPBGA (lidded) |
| MiMX8QX1AVLFZAC | Features not supported: GPU, Display Controller, VPU, 24-bit Parallel LCD, DSP | 1.2 GHz | 264 MHz | Automotive | 21 mm X 21 mm, 0.8 mm pitch, FCPBGA (lidded) |
| MiMX8QX2AVOFZAC | With DSP, 16-bit DDR. Features not supported: GPU, USB3, Display Controller, VPU, 24-bit Parallel LCD, ECC on DDR3 | 1.2 GHz | 264 MHz | Automotive | 17 mm X 17 mm, 0.8 mm pitch, FCPBGA (lidded) |
| MiMX8QX1AVOFZAC | With 16-bit DDR. Features not supported: GPU, USB3, Display Controller, VPU, 24-bit Parallel LCD, ECC on DDR3, DSP | 1.2 GHz | 264 MHz | Automotive | 17 mm X 17 mm, 0.8 mm pitch, FCPBGA (lidded) |

Table 3. i.MX 8DualXPlus Orderable part numbers

| Part Number | Options | Cortex-A35 Speed Grade | Cortex-M4F Speed Grade | Temperature Grade | Package |
|-----------------|---|------------------------|------------------------|-------------------|--|
| MiMX8DX6AVLFZAC | With GPU, VPU, DSP, 24-bit Parallel LCD | 1.2 GHz | 264 MHz | Automotive | 21 mm X 21 mm, 0.8 mm pitch, FCPBGA (lidded) |
| MiMX8DX5AVLFZAC | With GPU, VPU, 24-bit Parallel LCD | 1.2 GHz | 264 MHz | Automotive | 21 mm X 21 mm, 0.8 mm pitch, FCPBGA (lidded) |

Table 3. i.MX 8DualXPlus Orderable part numbers (continued)

| | | | | | |
|-----------------|--|---------|---------|------------|--|
| MiMX8DX2AVLFZAC | With DSP. Features not supported: GPU, Display Controller, VPU, 24-bit Parallel LCD | 1.2 GHz | 264 MHz | Automotive | 21 mm X 21 mm, 0.8 mm pitch, FCPBGA (lidded) |
| MiMX8DX1AVLFZAC | Features not supported: GPU, Display Controller, VPU, 24-bit Parallel LCD, DSP | 1.2 GHz | 264 MHz | Automotive | 21 mm X 21 mm, 0.8 mm pitch, FCPBGA (lidded) |
| MiMX8DX2AVOFZAC | With DSP, 16-bit DDR. Features not supported: GPU, USB3, Display Controller, VPU, 24-bit Parallel LCD, ECC on DDR3 | 1.2 GHz | 264 MHz | Automotive | 17 mm X 17 mm, 0.8 mm pitch, FCPBGA (lidded) |
| MiMX8DX1AVOFZAC | With 16-bit DDR. Features not supported: GPU, USB3, Display Controller, VPU, 24-bit Parallel LCD, ECC on DDR3, DSP | 1.2 GHz | 264 MHz | Automotive | 17 mm X 17 mm, 0.8 mm pitch, FCPBGA (lidded) |

1.2 System Controller Firmware (SCFW) Requirements

The i.MX 8 and 8X families require a minimum SCFW release version for correct operation and to prevent potential reliability issues.

The SCFW is released as part of a Board Support Package (e.g. Linux, Android) which may vary in version number for a specific BSP.

For example, NXP Yocto Linux release 4.14.98_2.3.0 contains SCFW version 1.3.0, NXP Yocto Linux release 4.14.98_2.0.0 GA contains SCFW version 1.2.10, whereas NXP Yocto Linux release 4.14.78_1.0.0GA contains SCFW version 1.1.10.

The released SCFW version associated within each BSP is the minimum version required to correctly support the wider BSP functionality.

Customers should always check that they are using the specific SCFW binary delivered within their chosen BSP release. Customers should not mix newer BSP versions with older revisions of the SCFW.

1.3 Package options

This data sheet lists and describes the superset of features in the i.MX 8X family of parts. The feature lists are subsets and differ between packages. This table describes the differences in feature availability per package.

Table 4. Feature differences per package¹

| Function | 21 x 21 mm 0.8 mm FCPBGA | 17 x 17 mm 0.8 mm FCPBGA | Comment |
|----------|---|--|--|
| DRAM | 32-bit LPDDR4, and 40-bit DDR3L with optional ECC | 16-bit LPDDR4 and 16-bit DDR3L (no ECC) | Due to the reduced DDR interface on the 17 x 17 package, the maximum DDR density supported is also reduced. |
| MIPI-CSI | 1 (4-lane plus dedicated GPIO) | 1 (4-lane interface and MIPI_CSI0_MCLK_OUT only) | MIPI_CSI0_I2C0, MIPI_CSI0_GPIO0_00 and MIPI_CSI0_GPIO0_01 balls removed |
| MIPI-DSI | 2 (4-lane plus dedicated GPIO) | 2 (4-lane interface and MIPI_DSIX_I2C0 only) | MIPI_DSIX_GPIO0_00 and MIPI_DSIX_GPIO0_01 balls removed (x is 0 or 1) |
| SAI | 4 | 2 | SAI0 and SAI1 (RX only) balls removed NOTE: By removing these interfaces the LCDIF is reduced from 24-bit to 18-bit maximum |
| SPI | 4 | 3 | SPI2 balls removed |
| USB | USB3 (SS3 plus OTG2) and OTG1 | OTG1 only | SS3 and OTG2 balls removed |
| USDHC | 2 | 1 | USDHC1 balls removed Note: Boot from SD not supported in 17x17 packages |

¹ Alternate IOMUX options may exist to replace some of the removed functionality, such as SAI0, SAI1 and SPI2; however, that will place different restrictions on the overall IOMUX capabilities of the smaller package parts.

1.4 Related resources

Table 5. Related resources

| Type | Description |
|------------------|--|
| Reference manual | The <i>i.MX 8DualX/8DualXPlus/8QuadXPlus Applications Processor Reference Manual</i> (IMX8DQXPRM) contains a comprehensive description of the structure and function (operation) of the SoC. |
| Data sheet | This data sheet includes electrical characteristics and signal connections. |
| Chip Errata | The chip mask set errata provides additional and/or corrective information for a particular device mask set. |
| Package drawing | Package dimensions are provided in Section 6, "Package information and contact assignments" . |
| Hardware guide | Contact an NXP representative for access. |

2 Architectural Overview

The following subsections provide an architectural overview of the i.MX 8QuadXPlus/8DualXPlus processor system.

2.1 Block Diagram

The following figure shows the functional modules in the processor system.

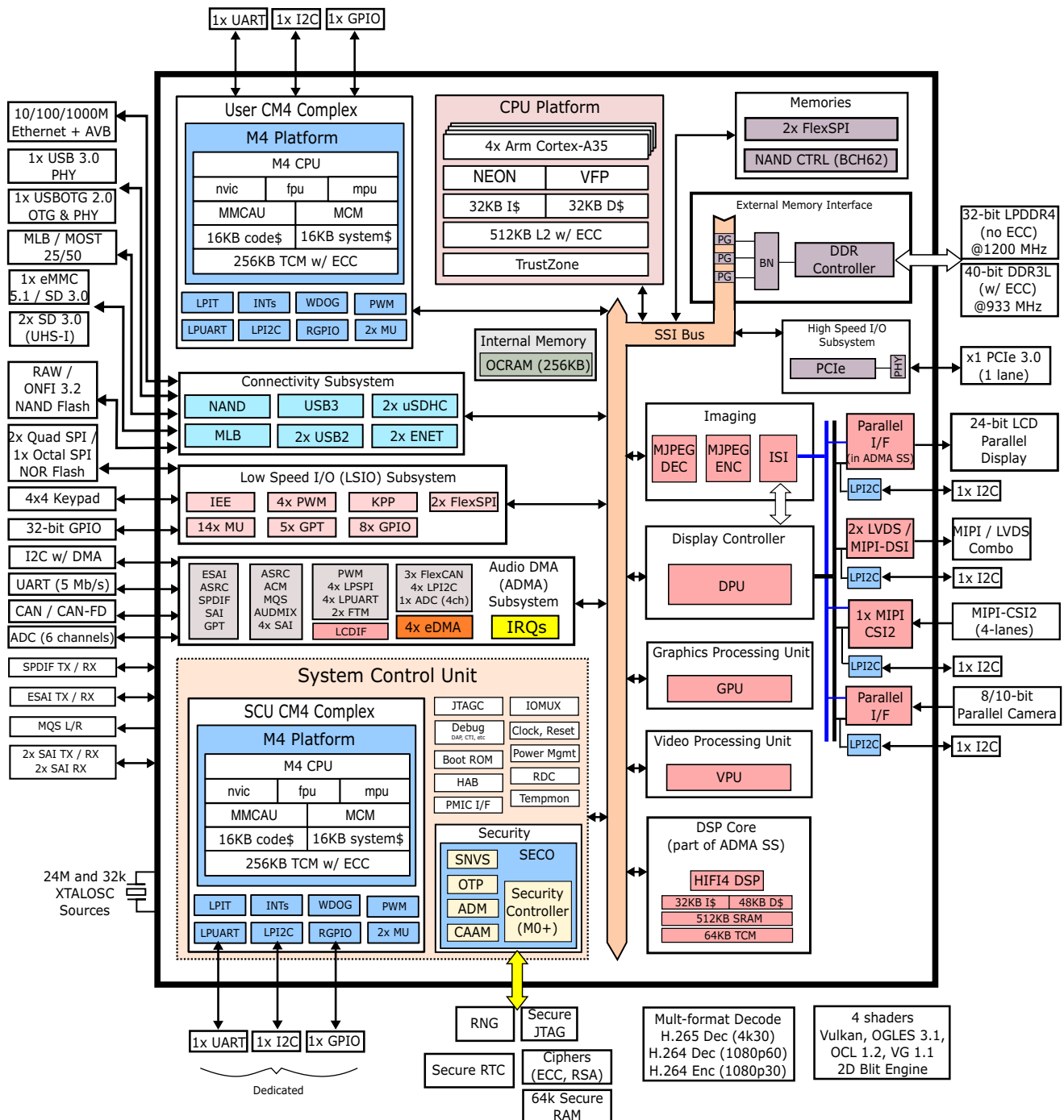

Figure 1. i.MX 8QuadXPlus/8DualXPlus System Block Diagram

3 Modules List

The i.MX 8QuadXPlus/8DualXPlus processors contain a variety of digital and analog modules. This table describes the processor modules in alphabetical order.

Table 6. i.MX 8QuadXPlus/8DualXPlus modules list

| Block Mnemonic | Block Name | Brief Description |
|----------------|--|--|
| ADC | Analog-to-Digital Converter | The analog-to-digital converter (ADC) is a successive approximation ADC designed for operation within a SoC. |
| APBH-DMA | NAND Flash and BCH ECC DMA Controller | The AHB-to-APBH bridge provides the chip with a peripheral attachment bus running on the AHB's HCLK, which includes the AHB-to-APB PIO bridge for a memory-mapped I/O to the APB devices, as well as a central DMA facility for devices on this bus and a vectored interrupt controller for the Arm core. |
| A35 | Arm (CPU1) | 2–4x Cortex-A35 CPUs with a 32KB L1 instruction cache and a 32 KB data cache. The CPUs share a 512 KB L2 cache. |
| ASRC | Asynchronous Sample Rate Converter | The Asynchronous Sample Rate Converter (ASRC) converts the sampling rate of a signal associated to an input clock into a signal associated to a different output clock. The ASRC supports concurrent sample rate conversion of up to 10 channels of about -120dB THD+N. The sample rate conversion of each channel is associated to a pair of incoming and outgoing sampling rates. The ASRC supports up to three sampling rate pairs. |
| BCH-62 | Binary-BCH ECC Processor | The BCH62 module provides up to 62-bit ECC for NAND Flash controller (GPMI2) |
| CAAM | Cryptographic Accelerator and Assurance Module | CAAM is a cryptographic accelerator and assurance module. CAAM implements several encryption and hashing functions, a run-time integrity checker, and a Pseudo Random Number Generator (PRNG). CAAM also implements a Secure Memory mechanism. In this device the security memory provided is 64 KB. |
| CTI | Cross Trigger Interface | CTI sends signals across the chip indicating that debug events have occurred. It is used by features of the Coresight infrastructure. |
| CTM | Cross Trigger Matrix | Cross Trigger Matrix IP is used to route triggering events between CTIs. |
| DAP | Debug Access Port | The DAP provides real-time access for the debugger without halting the core to: <ul style="list-style-type: none"> • System memory and peripheral registers • All debug configuration registers The DAP also provides debugger access to JTAG scan chains. |
| DC | Display Controller | Dual display controller |
| DDR Controller | DRAM Controller | <ul style="list-style-type: none"> • Memory types: LPDDR4 (no ECC) and DDR3L (ECC option) • One channel of 32-bit memory: <ul style="list-style-type: none"> • LPDDR4 up to 1.2 GHz • DDR3L up to 933MHz |
| DPR | Display/Prefetch/Resolve | The DPR prefetches data from memory and converts the data to raster format for display output. Raster source buffers can also be prefetched unconverted. The resolve process supports graphics and video formatted tile frame buffers and converts them to raster format. Embedded display memory is used as temporary storage for data which is sourced by the display controller to drive the display. |

Table 6. i.MX 8QuadXPlus/8DualXPlus modules list (continued)

| Block Mnemonic | Block Name | Brief Description |
|----------------|--------------------------------------|--|
| DTCP | Digital Transport Content Protection | Provides encryption function according to Digital Transmission Content Protection standard for traffic over MLB25/50. |
| eDMA | Enhanced Direct Memory Access | <ul style="list-style-type: none"> • 4× eDMA with a total of 96 channels (note: all channels are not assigned; see the product reference manual for more information): <ul style="list-style-type: none"> • 2× instances with 32 channels each • 2× instances with 16 channels each • Programmable source, destination addresses, transfer size, plus support for enhanced addressing modes • Internal data buffer, used as temporary storage to support 64-byte burst transfers, one outstanding transaction per DMA controller. • Transfer control descriptor organized to support two-deep, nested transfer operations • Channel service request via one of three methods: <ul style="list-style-type: none"> • Explicit software initiation • Initiation via a channel-to-channel linking mechanism for continuous transfers • Peripheral-paced hardware requests (one per channel) • Support for fixed-priority and round-robin channel arbitration • Channel completion reported via interrupt requests • Support for scatter/gather DMA processing • Support for complex data structures via transfer descriptors • Support to cancel transfers via software or hardware • Each eDMA instance can be uniquely assigned to a different resource domain, security (TZ) state, and virtual machine • In scatter-gather mode, each transfer descriptor's buffers can be assigned to different SMMU translation |
| ENET | Ethernet Controller | 2× 1 Gbps Ethernet + AVB (Audio Video Bridging, IEEE 802.1Qav) |
| ESAI | Enhanced Serial Audio Interface | <p>The Enhanced Serial Audio Interface (ESAI) provides a full-duplex serial port for serial communication with a variety of serial devices, including industry-standard codecs, SPDIF transceivers, and other processors. The ESAI consists of independent transmitter and receiver sections, each section with its own clock generator. All serial transfers are synchronized to a clock. Additional synchronization signals are used to delineate the word frames. The normal mode of operation is used to transfer data at a periodic rate, one word per period. The network mode is also intended for periodic transfers; however, it supports up to 32 words (time slots) per period. This mode can be used to build time division multiplexed (TDM) networks. In contrast, the on-demand mode is intended for non-periodic transfers of data and to transfer data serially at high speed when the data becomes available.</p> <p>The ESAI has 12 pins for data and clocking connection to external devices.</p> |
| FTM | FlexTimer | Provides input signal capture and PWM support |
| FlexCAN | Flexible Controller Area Network | Communication controller implementing the CAN with Flexible Data rate (CAN FD) protocol and the CAN protocol according to the CAN 2.0B protocol specification. |

Table 6. i.MX 8QuadXPlus/8DualXPlus modules list (continued)

| Block Mnemonic | Block Name | Brief Description |
|------------------------------|--------------------------------------|---|
| FlexSpi (Quad SPI/Octal SPI) | Flexible Serial Peripheral Interface | <ul style="list-style-type: none"> • Flexible sequence engine to support various flash vendor devices, including HyperBus™ devices: • Support for FPGA interface • Single, dual, quad, and octal mode of operation. • DDR/DTR mode wherein the data is generated on every edge of the serial flash clock. • Support for flash data strobe signal for data sampling in DDR and SDR mode. • Two identical serial flash devices can be connected and accessed in parallel for data read operations, forming one (virtual) flash memory with doubled readout bandwidth. |
| GIC | Generic Interrupt Controller | The GIC-500 handles all interrupts from the various subsystems and is ready for virtualization. |
| GPIO | General Purpose I/O Modules | Used for general purpose input/output to external devices. Each GPIO module supports 32 bits of I/O. |
| GPMI | General Purpose Media Interface | The GPMI module supports up to 8× NAND devices. 62-bit ECC (BCH) for NAND Flash controller (GPMI). The GPMI supports separate DMA channels per NAND device. |
| GPT | General Purpose Timer | Each GPT is a 32-bit “free-running” or “set and forget” mode timer with programmable prescaler and compare and capture register. A timer counter value can be captured using an external event and can be configured to trigger a capture event on either the leading or trailing edges of an input pulse. When the timer is configured to operate in “set and forget” mode, it is capable of providing precise interrupts at regular intervals with minimal processor intervention. The counter has output compare logic to provide the status and interrupt at comparison. This timer can be configured to run either on an external clock or on an internal clock. |
| GPU | Graphics Processing | 1× GC7000Lite with 4x Vec4 shader cores (16 execution units) |
| HiFi 4 DSP | Audio Processor | A highly optimized audio processor geared for efficient execution of audio and voice codecs and pre- and post-processing modules to offload the Arm core. |
| I ² C | I ² C Interface | I ² C provides serial interface for external devices. |
| IEE | | <ul style="list-style-type: none"> • Supports direct encryption and decryption of FlexSPI memory type • Provides decryption services (lower performance) for DRAM traffic • Supports I/O direct encrypted storage and retrieval • Support for a number of cryptographic standards: <ul style="list-style-type: none"> • 128/256-bit AES Encryption (AES-CTR, AES-XTS mode options) • Multiple keys supported: <ul style="list-style-type: none"> • Loaded via secure key channel from security block • Key selection is per access and based on source of transaction |
| IOMUXC | IOMUX Control | This module enables flexible I/O multiplexing. Each I/O pad has default and several alternate functions. The alternate functions are software configurable. |
| JPEG/dec | MJPEG engine for decode | Provides up to 4-stream decoding in parallel. |
| JPEG/enc | MJPEG engine for encode | Provides up to 4-stream encoding in parallel. |

Table 6. i.MX 8QuadXPlus/8DualXPlus modules list (continued)

| Block Mnemonic | Block Name | Brief Description |
|------------------|------------------------------------|--|
| KPP | Key Pad Port | The Keypad Port (KPP) is a 16-bit peripheral that can be used as a 4 x 4 keypad matrix interface or as general purpose input/output (I/O). |
| LPIT-1 LPIT-2 | Low-Power Periodic Interrupt Timer | Each LPIT is a 32-bit "set and forget" timer that starts counting after the LPIT is enabled by software. It is capable of providing precise interrupts at regular intervals with minimal processor intervention. It has a 12-bit prescaler for division of input clock frequency to get the required time setting for the interrupts to occur, and counter value can be programmed on the fly. |
| LPSP1 0–3 | Configurable SPI | Full-duplex enhanced Synchronous Serial Interface. It is configurable to support Master/Slave modes, four chip selects to support multiple peripherals. |
| M4F | Arm (CPU3) | <ul style="list-style-type: none"> • Cortex-M4F core • AHB LMEM (Local Memory Controller) including controllers for TCM and cache memories • 256 KB tightly coupled memory(TCM) (128 KB TCMU, 128 KB TCML) • 16 KB Code Bus Cache • 16 KB System Bus Cache • ECC for TCM memories and parity for code and system caches • Integrated Nested Vector Interrupt Controller (NVIC) • Wakeup Interrupt Controller (WIC) • FPU (Floating Point Unit) • Core MPU (Memory Protection Unit) • Support for exclusive access on the system bus • MMCAU (Crypto Acceleration Unit) • MCM (Miscellaneous Control Module) |
| MIPI CSI-2 | MIPI CSI-2 Interface | The MIPI CSI-2 IP provides MIPI CSI-2 standard camera interface ports. The MIPI CSI-2 interface supports up to 1.5 Gbps for up to 4 data lanes |
| MIPI-DSI/LVDS | MIPI DSI/LVDS Combo interface | The MIPI DSI IP provides DSI standard display serial interface with 4 data lines. The DSI interface supports 80 Mbps to 1.05 Gbps speed per data lane. The LVDS is a high-performance 2-channel serializer that interfaces with LVDS displays. Note: This is a combination PHY interface. It includes the digital logic and physical interface pins for both MIPI DSI (4 data lanes) and LVDS (4 differential pairs plus one for clock). The interface can be pinned out either as MIPI DSI or as LVDS. However, it does not allow for simultaneous use on one interface |
| MLB | MediaLB | Media local bus interface module that provides a link to a MOST® data network, using the standardized MediaLB protocol. Supports 3-wire interface (MLB25, MLB50). |
| MQS | Medium Quality Sound | Medium Quality Sound (MQS) is used to generate 2-channel medium quality PWM-like audio via two standard digital GPIO pins. |
| OCOTP_CTRL | OTP Controller | The On-Chip OTP controller (OCOTP_CTRL) provides an interface for reading, programming, and/or overriding identification and control information stored in on-chip fuse elements. The module supports electrically-programmable poly fuses (eFUSES). The OCOTP_CTRL also provides a set of volatile software-accessible signals that can be used for software control of hardware elements, not requiring non-volatility. The OCOTP_CTRL provides the primary user-visible mechanism for interfacing with on-chip fuse elements. Among the uses for the fuses are unique chip identifiers, mask revision numbers, cryptographic keys, JTAG secure mode, boot characteristics, and various control signals requiring permanent nonvolatility. |

Table 6. i.MX 8QuadXPlus/8DualXPlus modules list (continued)

| Block Mnemonic | Block Name | Brief Description |
|----------------------------|----------------------------|---|
| OCRAM | On-Chip Memory Controller | The On-Chip Memory controller (OCRAM) module is designed as an interface between the system's AXI bus and the internal (on-chip) SRAM memory module. The OCRM is used for controlling the 256 KB multimedia RAM through a 64-bit AXI bus. |
| Parallel CSI | Parallel CSI interface | The Parallel Port Capture Subsystem interfaces to Parallel CSI sensors and includes the following features: <ul style="list-style-type: none"> • Configurable interface logic to support the most commonly used parallel CMOS sensors • Configurable master clock output to drive external sensor (24 MHz nominal) • Up to 150 MHz input clock from sensor • Input data formats supported: <ul style="list-style-type: none"> • 8-bit/10-bit BT.656 • 8-bit/24-bit data port for RGB, YCbCr, and YUV data input • 8-bit/12-bit/10-bit/16-bit data port for Bayer data input Note: For some formats a single pixel is sent per clock, for others two or three are sent per clock. |
| PCIe | PCI Express 3.0 | The PCIe IP provides PCI Express Gen 3.0 functionality . |
| PRG | Prefetch/Resolve Gasket | The PRG is a gasket which translates system memory accesses to local display RTRAM accesses for display refresh. It works with the DPR to complete the prefetch and resolving operations needed to drive the display. |
| PWM | Pulse Width Modulation | The pulse-width modulator (PWM) has a 16-bit counter and is optimized to generate sound from stored sample audio images and it can also generate tones. It uses 16-bit resolution and a 4x16 data FIFO to generate square waveforms. |
| RAM 64 KB Secure RAM | Secure/non-secure RAM | Secure/non-secure Internal RAM, interfaced through the CAAM. |
| RAM 256 KB | Internal RAM | Internal RAM, which is accessed through OCRM memory controllers. |
| RNG | Random Number Generator | The purpose of the RNG is to generate cryptographically strong random data. It uses a true random number generator (TRNG) and a pseudo-random number generator (PRNG) to achieve true randomness and cryptographic strength. The RNG generates random numbers for secret keys, per message secrets, random challenges, and other similar quantities used in cryptographic algorithms. |
| SAI | I2S/SSI/AC97 Interface | The SAI module provides a synchronous audio interface that supports full duplex serial interfaces with frame synchronization, such as I2S, AC97, TDM, and codec/DSP interfaces. |
| SECO | Security Controller | Core and associated memory and hardware responsible for key management. |
| SJC | Secure JTAG Controller | The SJC provides the JTAG interface, which is compatible with JTAG TAP standards, to internal logic. This device uses JTAG port for production, testing, and system debugging. Additionally, the SJC provides BSR (Boundary Scan Register) standard support, which is compatible with IEEE1149.1 and IEEE1149.6 standards. The JTAG port must be accessible during platform initial laboratory bring-up, for manufacturing tests and troubleshooting, as well as for software debugging by authorized entities. The SJC incorporates three security modes for protecting against unauthorized accesses. Modes are selected through eFUSE configuration. |

Table 6. i.MX 8QuadXPlus/8DualXPlus modules list (continued)

| Block Mnemonic | Block Name | Brief Description |
|----------------|--|---|
| SNVS | Secure Non-Volatile Storage | Secure Non-Volatile Storage, including Secure Real Time Clock, Security State Machine, Master Key Control, and Violation/Tamper Detection and reporting. |
| SPDIF | Sony Philips Digital Interconnect Format | The Sony/Philips Digital Interface (SPDIF) audio block is a stereo transceiver that allows the processor to receive and transmit digital audio. The SPDIF transceiver allows the handling of both SPDIF channel status (CS) and User (U) data and includes a frequency measurement block that allows the precise measurement of an incoming sampling frequency. |
| TEMPMON | Temperature Monitor | The temperature monitor/sensor IP module for detecting high temperature conditions. The temperature read out does not reflect case or ambient temperature. It reflects the temperature in proximity of the sensor location on the die. Temperature distribution may not be uniformly distributed; therefore, the read-out value may not be the reflection of the temperature value for the entire die. |
| UART | UART Interface | <ul style="list-style-type: none"> • High-speed TIA/EIA-232-F compatible, up to 5.0 Mbps • Serial IR interface low-speed, IrDA-compatible (up to 115.2 Kbit/s) • 9-bit or Multidrop mode (RS-485) support (automatic slave address detection) • 7, 8, 9, or 10-bit data characters (7-bits only with parity) • 1 or 2 stop bits • Programmable parity (even, odd, and no parity) • Hardware flow control support for request to send (RTS_B) and clear to send (CTS_B) signals |
| USB3/USB2 | | <p>The USB3/USB2 OTG module has been specified to perform USB 3.0 dual role and USB 2.0 On-The-Go (OTG) compatible with the USB 3.0, and USB 2.0 specification with OTG supplementary specifications. This controller supports two independent USB cores (1× USB3.0 dual-role, 1× USB2.0 OTG) and includes the PHY and I/O interfaces to support this operation. The full pinout of the USB 3.0 controller includes the signaling for both USB 3.0 and USB 2.0. This does not mean there is a separate USB 2.0 controller that can be used independently and simultaneously with USB 3.0. This device has an additional separate, independent USB 2.0 OTG controller which can be used simultaneously with this USB 3.0. Specific features requested for this updated module:</p> <ul style="list-style-type: none"> • Super Speed (5 Gbps), High Speed (480 Mbps), full speed (12 Mbps) and low speed (1.5 Mbps) • Fully compatible with the USB 3.0 specification (backward compatible with USB 2.0) • Fully compatible with the USB On-The-Go supplement to the USB 2.0 specification • Hardware support for OTG signaling • Host Negotiation Protocol (HNP) and Session Request Protocol (SRP) implemented in hardware, which can also be controlled by software |

Table 6. i.MX 8QuadXPlus/8DualXPlus modules list (continued)

| Block Mnemonic | Block Name | Brief Description |
|----------------|---|---|
| USBOH | | <p>The USBOH module has been specified which performs USB 2.0 On-The-Go (OTG) and USB 2.0 Host functionality compatible with the USB 2.0 with OTG supplement specification. This controller supports one independent USB core (1× USB2.0 OTG) and includes the PHY and I/O interfaces to support this operation.</p> <p>Key features:</p> <ul style="list-style-type: none"> • One USB2.0 OTG controller • High Speed (480 Mbps), full speed (12 Mbps) and low speed (1.5 Mbps) • Fully compatible with the USB 2.0 specification • Fully compatible with the USB On-The-Go supplement to the USB 2.0 specification • Hardware support for OTG signaling <p>Host Negotiation Protocol (HNP) and Session Request Protocol (SRP) implemented in hardware, which can also be controlled by software</p> |
| uSDHC | SD/eMMC and SDXC Enhanced Multi-Media Card / Secure Digital Host Controller | <p>The uSDHC is a host controller used to communicate with external low cost data storage and communication media. It supports the previous versions of the MultiMediaCard (MMC) and Secure Digital Card (SD) standards. Specifically, the uSDHC supports:</p> <ul style="list-style-type: none"> • SD Host Controller Standard Specification v3.0 with the exception that all the registers do not match the standards address mapping. • SD Physical Layer Specification v3.0 UHS-I (SDR104/DDR50) • SDIO specification v3.0 • eMMC System Specification v5.1 |
| VPU | Video Processing Unit | See the device reference manual for the complete list of the VPU's decoding/encoding capabilities. |
| WDOG | Watchdog | The Watchdog Timer supports two comparison points during each counting period. Each of the comparison points is configurable to evoke an interrupt to the Arm core, and a second point evokes an external event on the WDOG line. |
| XTAL OSC24M | | The 24 MHz clock source is an external crystal that acts as one of two main clock sources to the chip. The OSC24M is used as the source clock for subsystem PLLs. OSC24M can be turned off by the System Control Unit (SCU) during sleep mode. |
| XTAL OSC32K | | The 32 KHz clock source is an external crystal that is one of two main clock sources to the chip. The OSC32K is intended to be always on and is distributed by the SCU to modules in the chip. |

3.1 Special Signal Considerations

The package contact assignments can be found in [Section 6, “Package information and contact assignments”](#). Signal descriptions are defined in the device reference manual.

3.2 Recommended Connections for Unused Interfaces

The recommended connections for unused analog interfaces can be found in the section, “Unused Input/Output Terminations,” in the hardware development guide for this device.

4 Electrical characteristics

This section provides the device and module-level electrical characteristics for these processors.

4.1 Chip-level conditions

This section provides the device-level electrical characteristics for the SoC. See the following table for a quick reference to the individual tables and sections.

Table 7. Chip-level conditions

| For these characteristics, ... | Topic appears ... |
|--|-------------------|
| Absolute maximum ratings | on page 17 |
| FCPBGA package thermal resistance data | on page 19 |
| Operating ranges | on page 20 |
| External Input Clock Frequency | on page 22 |
| Maximum supply currents | on page 23 |
| USB 2.0 PHY typical current consumption in Power-Down Mode | on page 26 |
| USB 3.0 PHY typical current consumption in Power-Down Mode | on page 26 |
| Typical current consumption in Power-Down mode for USB 2.0 PHY embedded in USB 3.0 PHY | on page 26 |

4.1.1 Absolute Maximum Ratings

CAUTION

Stresses beyond those listed under [Table 8](#) may affect reliability or cause permanent damage to the device. These are stress ratings only. Functional operation of the device at these or any other conditions beyond those indicated in the “[Operating ranges](#)” or other parameter tables is not implied. Exposure to absolute-maximum-rated conditions for extended periods will affect device reliability.

Table 8. Absolute maximum ratings

| Parameter Description | Symbol | Min | Max | Units |
|-----------------------------|--------------|------|------|-------|
| Core Supplies Input Voltage | VDD_A35 | -0.3 | 1.2 | V |
| | VDD_GPU | | | |
| | VDD_MAIN | | | |
| DDR PHY supplies | VDD_DDR_VDDQ | -0.3 | 1.75 | V |

Electrical characteristics

Table 8. Absolute maximum ratings (continued)

| Parameter Description | Symbol | Min | Max | Units |
|---|------------------------------------|------|------|-------|
| 1.0V IO supplies | VDD_MIPI_1P0 | -0.3 | 1.2 | V |
| | VDD_USB_OTG_1P0 | | | |
| IO Supply for GPIO Type 1.8V IO Single supply | VDD_ADC_1P8 | -0.5 | 2.1 | V |
| | VDD_ADC_DIG_1P8 | | | |
| | VDD_ANA0_1P8 (IO, analog, OSC SCU) | | | |
| | VDD_ANA1_1P8 (IO, analog, OSC SCU) | | | |
| | VDD_DDR_PLL_1P8 (memory PLLs) | | | |
| | VDD_MIPI_1P8 (PHY, GPIO) | | | |
| | VDD_MIPI_CSI_DIG_1P8 (PHY, GPIO) | | | |
| | VDD_PCIE_1P8 (PHY) | | | |
| | VDD_USB_1P8 (PHY, GPIO) | | | |
| IO Supply for GPIO Type 1.8 / 2.5 / 3.3V IO Tri-voltage Supply | VDD_ENET0_VSELECT_1P8_2P5_3P3 | -0.3 | 3.8 | V |
| | VDD_ENET0_1P8_2P5_3P3 | | | |
| | VDD_ESAI_SPDIF_1P8_2P5_3P3 | | | |
| IO Supply for GPIO Type 1.8 / 3.3V IO Dual Voltage Supply | VDD_CAN_UART_1P8_3P3 | -0.3 | 3.8 | V |
| | VDD_CSI_1P8_3P3 | | | |
| | VDD_EMMC0_1P8_3P3 | | | |
| | VDD_EMMC0_VSELECT_1P8_3P3 | | | |
| | VDD_ENET_MDIO_1P8_3P3 | | | |
| | VDD_MIPI_DSI_DIG_1P8_3P3 | | | |
| | VDD_PCIE_DIG_1P8_3P3 | | | |
| | VDD_QSPI0A_1P8_3P3 | | | |
| | VDD_QSPI0B_1P8_3P3 | | | |
| | VDD_SPI_MCLK_UART_1P8_3P3 | | | |
| | VDD_SPI_SAI_1P8_3P3 | | | |
| | VDD_TMPR_CSI_1P8_3P3 | | | |
| | VDD_USB_3P3 (PHY & GPIO) | | | |
| | VDD_USDHC1_1P8_3P3 | | | |
| | VDD_USDHC1_VSELECT_1P8_3P3 | | | |
| SNVS Coin Cell | VDD_SNVS_4P2 | -0.3 | 4.3 | V |
| USB VBUS (OTG2) | USB_OTG2_VBUS | -0.3 | 3.63 | V |
| USB VBUS (OTG1) | USB_OTG1_VBUS | -0.3 | 5.5 | V |

Table 8. Absolute maximum ratings (continued)

| Parameter Description | Symbol | Min | Max | Units |
|--|-------------------------|------|-------------------------|-------|
| I/O Voltage for USB Drivers | USB_OTG1_DP/USB_OTG1_DN | -0.3 | 3.63 | V |
| | USB_OTG2_DP/USB_OTG2_DN | | | |
| I/O Voltage for ADC | ADC_INx | -0.1 | 2.1 | V |
| Vin/Vout input/output voltage range (GPIO Type Pins) | Vin/Vout | -0.3 | OVDD+0.3 ¹ | V |
| Vin/Vout input/output voltage range (DDR pins) | Vin/Vout | -0.3 | OVDD+0.4 ^{1,2} | V |
| ESD immunity (HBM). | Vesd_HBMX | — | 1000 | V |
| ESD immunity (CDM). | Vesd_CDM | — | 250 | V |
| Storage temperature range | Tstorage | -55 | 150 | °C |

¹ OVDD is the I/O supply voltage.

² The absolute maximum voltage includes an allowance for 400 mV of overshoot on the I/O pins. Per JEDEC standard the allowed signal overshoot must be derated if NVCC_DRAM exceeds 1.575 V.

4.1.2 Thermal resistance

4.1.2.1 FCPBGA package thermal resistance

This table provides the FCPBGA package thermal resistance data.

Table 9. FCPBGA package thermal resistance data

| Rating | Board Type ¹ | Symbol | Value, 21x21 mm package | Value, 17x17 mm package | Unit |
|---|-------------------------|------------------|-------------------------------|----------------------------------|------|
| Junction to Ambient Thermal Resistance ² | JESD51-9, 2s2p | R _{θJA} | 15.2 | 15.8 | °C/W |
| Junction to Package Top Thermal Resistance ² | JESD51-9, 2s2p | Ψ _{JT} | 0.1 | 0.1 | °C/W |
| Junction to Case Thermal Resistance ³ | JESD51-9, 1s | R _{θJC} | 0.7 | 0.9 | °C/W |

¹ Thermal test board meets JEDEC specification for this package (JESD51-9).

² Determined in accordance to JEDEC JESD51-2A natural convection environment. Thermal resistance data in this report is solely for a thermal performance comparison of one package to another in a standardized specified environment. It is not meant to predict the performance of a package in an application-specific environment.

³ Junction-to-Case thermal resistance determined using an isothermal cold plate. Case temperature refers to the mold surface temperature at the package top side dead center.

4.1.3 Operating Ranges

The following table provides the operating ranges of these processors.

Table 10. Operating ranges¹

| Symbol | Description | Mode | Min | Typ | Max | Unit | Comments |
|---|---|-----------|------|------|------|------|--|
| VDD_A35 | Power supply of Cortex-A35 cluster | Overdrive | 1.05 | 1.10 | 1.15 | V | Max frequency: 1.2 GHz |
| | | Nominal | 0.95 | 1.00 | 1.10 | V | Max frequency: 900 MHz |
| VDD_GPU | Power supply of GPU instance | Overdrive | 1.05 | 1.10 | 1.15 | V | Max frequencies: • Shaders: 850MHz • Core: 700 MHz |
| | | Nominal | 0.95 | 1.00 | 1.10 | V | Max frequencies: shaders: 372 MHz; core: 372 MHz |
| VDD_MAIN ² | Power supply of remaining core logic | N/A | 0.95 | 1.00 | 1.10 | V | Max freq.: HiFi4 DSP 640 MHz Max freq.: M4 264 MHz Max freq.: VPU 600 MHz |
| VDD_DDR_VDDQ | Power supplies of memory IOs | DDR3L | 1.30 | 1.35 | 1.45 | V | Max frequency: 933 MHz to support DDR3L-1866 |
| | | LPDDR4 | 1.06 | 1.10 | 1.17 | V | Max frequency: 1.2GHz to support LPDDR4-2400 |
| VDD_DDR_PLL_1P8 | Power supplies of memory PLLs | N/A | 1.65 | 1.80 | 1.95 | V | PLL supply can be merged with other 1.8V supplies with proper on board decoupling. |
| VDD_MIPI_1P0 | Power supplies of PHYs (1.0V part) | N/A | 0.95 | 1.00 | 1.10 | V | — |
| VDD_ANA0_1P8 VDD_ANA1_1P8 | Power supplies of IOs, analog and oscillator of the SCU | N/A | 1.65 | 1.80 | 1.95 | V | These balls shall be powered by a dedicated supply |
| VDD_ADC_1P8 VDD_ADC_DIG_1P8 VDD_MIPI_1P8 VDD_MIPI_CSI_DIG_1P8 VDD_USB_1P8 | Power supplies of PHYs (1.8V part) and GPIO operating at 1.8V only. | N/A | 1.65 | 1.80 | 1.95 | V | — |
| VDD_PCIE_1P8 | Power supplies of PCIE PHY (1.8 V part) | | 1.71 | 1.80 | 1.89 | V | — |

Table 10. Operating ranges¹ (continued)

| Symbol | Description | Mode | Min | Typ | Max | Unit | Comments |
|--|--|------|------|------|------|------|--|
| VDD_USB_3P3 | Power supplies of PHYs (3.3V part) and GPIO operating at 3.3V only | N/A | 3.00 | 3.30 | 3.60 | V | — |
| VDD_CAN_UART_1P8_3P3 VDD_CSI_1P8_3P3 VDD_EMMC0_1P8_3P3 VDD_EMMC0_VSELECT_1P8_3P3 VDD_ENET_MDIO_1P8_3P3 VDD_MIPI_DSI_DIG_1P8_3P3 VDD_PCIE_DIG_1P8_3P3 VDD_QSPI0A_1P8_3P3 VDD_QSPI0B_1P8_3P3 VDD_SPI_MCLK_UART_1P8_3P3 VDD_SPI_SAI_1P8_3P3 VDD_TMPR_CSI_1P8_3P3 VDD_USDHC1_1P8_3P3 VDD_USDHC1_VSELECT_1P8_3P3 | Power supplies of GPIO supporting both 1.8V or 3.3V | 1.8V | 1.65 | 1.80 | 1.95 | V | When VDD_USDHC1_1P8_3P3 is used to support an SD card, then it shall be on a dedicated 1.8V/3.3V regulator. When VDD_SIM0_1P8_3P3 is used to support a SIM card, it shall be on a dedicated 1.8V/3.3V regulator. When VDD_TMPR_CSI_1P8_3P3 is used as a GPIO it can be connected to the 1.8/3.3V supply. VDDs of this list targeting 1.8V can share 1.8V regulator of 1.8V only VDDs VDDs of this list targeting 3.3V can share 3.3V regulator of 3.3V only VDDs |
| | | 3.3V | 3.00 | 3.30 | 3.60 | V | — |
| VDD_ENET0_1P8_2P5_3P3 VDD_ENET0_VSELECT_1P8_2P5_3P3 VDD_ESAI_SPDIF_1P8_2P5_3P3 | Power supplies of ethernet IOs | 1.8V | 1.65 | 1.80 | 1.95 | V | — |
| | | 2.5V | 2.40 | 2.50 | 2.60 | V | — |
| | | 3.3V | 3.00 | 3.30 | 3.60 | V | — |
| VDD_SNVS_4P2 | Power supply of SNVS | N/A | 2.80 | 3.30 | 4.20 | V | It can be supplied by a backup battery: a coin cell or a super cap. |
| Output of embedded LDOs | | | | | | | |
| VDD_PCIE_LDO_1P0_CAP VDD_USB_SS3_LDO_1P0_CAP | 1.0V output of embedded LDOs | N/A | — | 1.00 | — | V | — |
| VDD_SNVS_LDO_1P8_CAP | 1.8V output of SNVS embedded LDO | N/A | — | 1.80 | — | V | — |

Table 10. Operating ranges¹ (continued)

| Symbol | Description | Mode | Min | Typ | Max | Unit | Comments |
|--|-------------|------|-----|------|-----|------|--|
| Power supplies that shall be connected to output of an embedded LDO | | | | | | | |
| VDD_TMPR_CSI_1P8_3P3 | — | N/A | — | 1.80 | — | V | Shall be connected to VDD_SNVLS_LDO_1P8_CAP when used as a tamper pin. In CSI mode use an external 1.8 V supply. In this case, follow the 1.8 V I/O specification above. |
| VDD_USB_OTG_1P0 | — | N/A | — | 1.00 | — | V | Shall be externally connected to VDD_USB_SS3_LDO_1P0_CAP |
| Junction temperature | | | | | | | |
| Junction temperature | — | — | -40 | — | 125 | °C | — |

¹ Voltage ranges are defined to group as many supplies as possible. Some supplies may have a wider range than listed here.

² During low power state (see Section 4.1.6, "Low power mode supply currents"), this voltage can be dropped to 0.8 V +/- 3% for retention.

4.1.4 External clock sources

Each processor has two external input system clocks: a low frequency (RTC_XTALI) and a high frequency (XTALI).

The RTC_XTALI is used for real time functions. It supplies the clock for real time clock operation and for slow-system and watchdog counters. The clock input can be connected to either an external oscillator or a crystal using the internal oscillator amplifier.

The system clock input XTALI is used to generate the main system clock. It supplies the PLLs and other peripherals. The system clock input requires a crystal using the internal oscillator amplifier.

The PCIe oscillator can be sourced internally or input to the chip. In both cases, it is a 100 MHz nominal clock using HCSL signaling to provide the PCIe reference clock.

The following table shows the interface frequency requirements.

Table 11. External Input Clock Frequency

| Parameter Description | Symbol | Min | Typ | Max | Unit |
|-------------------------------------|------------|-----|---------------------------|------|------|
| RTC_XTALI Oscillator ^{1,2} | f_{ckil} | — | 32.768 ³ /32.0 | — | kHz |
| XTALI Oscillator ^{4,2} | f_{xtal} | — | 24 | — | MHz |
| PCIe oscillator ⁵ | f_{100M} | — | 100 | — | MHz |
| Frequency accuracy | — | — | — | ±300 | ppm |

- ¹ External oscillator or a crystal with internal oscillator amplifier.
- ² The required frequency stability of this clock source is application dependent. For recommendations, see the hardware development guide for this device.
- ³ Recommended nominal frequency 32.768 kHz.
- ⁴ Fundamental frequency crystal with internal oscillator amplifier.
- ⁵ If using an external clock instead of the internal clock source, an HCSL-compatible clock is required.

The typical values shown in [Table 11](#) are required for use with NXP board support packages (BSPs) to ensure precise time keeping and USB operations.

4.1.5 Maximum Supply Currents

NOTE

Some of the numbers shown in this table are based on the companion regulator limits and not actual use cases. Work is in progress to provide use case-based numbers in future data sheet releases.

Table 12. Maximum supply currents

| Symbol | Value | Unit | Comments |
|-------------------------------|-------|------|----------------------------------|
| VDD_A35 ¹ | 2500 | mA | |
| VDD_GPU ¹ | 2500 | mA | |
| VDD_MAIN | 5000 | mA | |
| VDD_DDR_VDDQ | 1200 | mA | Does not comprehend IO of memory |
| VDD_DDR_PLL_1P8 | 20 | mA | |
| VDD_ANA0_1P8 | 200 | mA | |
| VDD_ANA1_1P8 | 200 | mA | |
| VDD_MIPI_1P0 | 100 | mA | |
| VDD_MIPI_1P8 | 115 | mA | |
| VDD_ADC_DIG_1P8 | 18 | mA | |
| VDD_CAN_UART_1P8_3P3 | 30 | mA | |
| VDD_CSI_1P8_3P3 | 12 | mA | |
| VDD_EMMC0_1P8_3P3 | 30 | mA | |
| VDD_EMMC0_VSELECT_1P8_3P3 | 30 | mA | |
| VDD_ENET_MDIO_1P8_3P3 | 15 | mA | |
| VDD_ENET0_1P8_2P5_3P3 | 30 | mA | |
| VDD_ENET0_VSELECT_1P8_2P5_3P3 | 30 | mA | |
| VDD_ESAI_SPDIF_1P8_2P5_3P3 | 39 | mA | |
| VDD_MIPI_CSI_DIG_1P8 | 15 | mA | |

Electrical characteristics

Table 12. Maximum supply currents (continued)

| Symbol | Value | Unit | Comments |
|----------------------------|-------|------|--|
| VDD_MIPI_DSI_DIG_1P8_3P3 | 24 | mA | |
| VDD_PCIE_DIG_1P8_3P3 | 9 | mA | |
| VDD_QSPI0A_1P8_3P3 | 40 | mA | |
| VDD_QSPI0B_1P8_3P3 | 40 | mA | |
| VDD_SPI_MCLK_UART_1P8_3P3 | 36 | mA | |
| VDD_SPI_SAI_1P8_3P3 | 48 | mA | |
| VDD_TMPR_CSI_1P8_3P3 | 30 | mA | |
| VDD_USDHC1_1P8_3P3 | 30 | mA | |
| VDD_USDHC1_VSELECT_1P8_3P3 | 20 | mA | |
| VDD_ADC_1P8 | 5 | mA | |
| VDD_USB_OTG_1P0 | 36 | mA | Shall be externally connected to VDD_USB_SS3_LDO_1P0_CAP |
| VDD_USB_1P8 | 175 | mA | |
| VDD_USB_3P3 | 40 | mA | |
| VDD_PCIE_1P8 | 255 | mA | |
| VDD_SNVS_4P2 ² | 5 | mA | Start-up current |

¹ VDD_A35 and VDD_GPU can be combined with one power supply.

² Under normal operating conditions, the maximum current on VDD_SNVS_4P2 is shown Table 11. During initial power on, VDD_SNVS_4P2 can draw up to 5 mA if the supply is capable of sourcing that current. If less than 5 mA is available, the VDD_SNVS_LDO_1P8_CAP charge time will increase.

4.1.6 Low power mode supply currents

The following table shows the current core consumption (not including I/O) in selected low power modes.

Table 13. i.MX 8QuadXPlus/8DualXPlus Key State (KSx) power consumption

| Mode | Test conditions | Supply | Max | Unit |
|------------------|--|----------------------|------|------|
| KS0 | SNVS only, all other supplies OFF. RTC running, tamper not active, external 32K crystal. | VDD_SNVS_4P2 (4.2 V) | 50 | μA |
| KS1 ¹ | RAM and IO state retained. DRAM in self-refresh, associated I/O's OFF. 32K running, 24M, PLLs and ring oscillators OFF. PHYs are in idle state. A35 and GPU supplies OFF. MAIN ² dropped to 0.8 V. | VDD_ANAx_1P8 (1.8 V) | 0.9 | mA |
| | | VDD_A35 (OFF) | — | mA |
| | | VDD_GPU (OFF) | — | mA |
| | | VDD_MAIN (0.8 V) | 33 | mA |
| | | VDD_DDR_VDDQ (1.1 V) | 0.5 | mA |
| | | Total | 28.6 | mW |
| KS4 ³ | Leakage test, not intended as a customer use case. Overdrive conditions set, memories active, all sub-systems powered ON. Active power minimized. | VDD_ANAx_1P8 (1.8 V) | 3.6 | mA |
| | | VDD_A35 (1.1 V) | 660 | mA |
| | | VDD_GPU (1.1 V) | 300 | mA |
| | | VDD_MAIN (1.0 V) | 1700 | mA |
| | | Total | 2763 | mW |

¹ Maximum values are for 25 °C T_{ambient}.

² 0.8 V nominal—voltage specification under this case is ± 3%.

³ Maximum values are for 125 °C T_{junction}.

4.1.7 USB 2.0 PHY typical current consumption in Power-Down mode

In power down mode, everything is powered down, including the VBUS valid detectors, typical condition. The following table shows the USB interface typical current consumption in Power-Down mode.

Table 14. USB 2.0 PHY typical current consumption in Power-Down Mode

| | VDD_USB_3P3 (3.3 V) | VDD_USB_1P8 (1.8 V) | VDD_USB_OTG_1P0 (1.0 V) |
|---------|---------------------|---------------------|-------------------------|
| Current | 1 μ A | 0.06 μ A | 0.5 μ A |

4.1.8 USB 3.0 PHY typical current consumption in Power-Down mode

In power down mode, everything is powered down, including the VBUS valid detectors, typical condition. The following table shows the USB interface typical current consumption in Power-Down mode.

Table 15. USB 3.0 PHY typical current consumption in Power-Down Mode

| | — | VDD_USB_1P8 (1.8 V) | VDD_USB_OTG_1P0 (1.0 V) |
|---------|---|---------------------|-------------------------|
| Current | — | 10 μ A | 70 μ A |

The following table shows the current consumption for the USB 2.0 PHY embedded in the USB 3.0 PHY.

Table 16. Typical current consumption in Power-Down mode for USB 2.0 PHY embedded in USB 3.0 PHY

| | VDD_USB_3P3 (3.3 V) | VDD_USB_1P8 (1.8 V) | VDD_USB_OTG2_1P0VDD_U SB_OTG_1P0 (1.0 V) |
|---------------------|---------------------|---------------------|---|
| Current—Host mode | 22.6 μ A | 12.7 μ A | 81.5 μ A |
| Current—Device mode | 12.6 μ A | 85.7 μ A | 78.5 μ A |

4.1.8.1 USB 3.0 Type-C connector considerations

The device supports USB 3.0 Type-C connection when used in conjunction with the following devices:

- PTN36043
- PTN5150A
- NX5P3090UK

NXP supports many other configurations and implementations for USB 3.0 Type-C connections. See [NXP USB Type-C: True Plug'n Play](#).

4.2 Power supplies requirements and restrictions

The system design must comply with power-up sequence, power-down sequence, and steady state guidelines as described in this section to ensure the reliable operation of the device. Any deviation from these sequences may result in the following situations:

- Excessive current during power-up phase
- Prevention of the device from booting
- Irreversible damage to the processor

4.2.1 Power-up sequence

The device has the following power-up sequence requirements:

- Supply group 0 (SNVS) must be powered first. It is expected that group 0 will typically remain always on after the first power-on.
- Supply group 1 (MAIN and SCU) and group 0 must both be powered to their nominal values prior to boot. They must power up after or simultaneously with group 0.
- Supply group 2 (I/O's and DDR interface) consists of those modules required to start the boot process by accessing external storage devices. These must be fully powered prior to POR release if booting from one of these supplies interfaces. They must power up after or simultaneously with group 1.
- Supply group 3 consists of the remaining portions of the SoC. This includes nonboot I/O voltages and supplies for the major computational units. These can be sequenced in any order and as required to perform the desired functions for the intended application. They must power up after or simultaneously with group 2.

NOTE

The definition of “power-up” refers to a stable voltage operating within the range defined in [Table 10](#). This should be taken into consideration, along with the different capacitive loading on each rail, if considering simultaneous switch-on of the different supply groups.

4.2.2 Power-down sequence

The device processor has the following power-down sequence requirements:

- Supply group 0 must be turned off last, after all other supplies.
- Supply group 1 can be turned off just prior to group 0.

All remaining supplies can be turned off prior to group 1.

NOTE

When switching off supply group 0 (SNVS), VDD_SNVS_4P2 must be discharged below 2.4 V before starting the next power-up sequence to ensure correct operation. This will generate a full SNVS reset, allowing correct operation on the next power-up sequence. This would also be a requirement to clear any security related flag as a result of an SNVS voltage drop, when tamper features are enabled.

4.2.3 Power Supplies Usage

The following table shows the power supplies usage by group.

Table 17. Power supplies usage

| Supply Groups | Voltage | | | | |
|---------------|----------------------|-----------------------------------|-----------------------------------|--------------------------------|-------------|
| Group 0 | 2.4 - 4.2v | 1.8v internal LDO | | | |
| | VDD_SNV5_4P2 | VDD_TMPR_CSI_1P8_3P3 ¹ | | | |
| Group 1 | 1.0v | 1.8v | | | |
| | VDD_MAIN | VDD_ANAx_1P8 | | | |
| | VDD_MIPI_1P0 | | | | |
| Group 2 | 1.1 - 1.35v | 1.8v | 1.8v or 3.3v | 1.8v or 3.3v switchable | 3.3v |
| | VDD_DDR_VDDQ | VDD_ADC_DIG_1P8 | VDD_CAN_UART_1P8_3P3 | VDD_EMMC0_1P8_3P3 | VDD_USB_3P3 |
| | | VDD_ADC_1P8 | VDD_CSI_1P8_3P3 | VDD_USDHC1_1P8_3P3 | |
| | | VDD_DDR_PLL_1P8 | VDD_EMMC0_VSELECT_1P8_3P3 | | |
| | | VDD_MIPI_1P8 | VDD_ENET_MDIO_1P8_3P3 | | |
| | | VDD_MIPI_CSI_DIG_1P8 | VDD_MIPI_DSI_DIG_1P8_3P3 | | |
| | | VDD_PCIE_1P8 | VDD_PCIE_DIG_1P8_3P3 | | |
| | | VDD_USB_1P8 | VDD_QSPI0x_1P8_3P3 | | |
| | | | VDD_SPI_MCLK_UART_1P8_3P3 | | |
| | | | VDD_SPI_SAI_1P8_3P3 | | |
| | | | VDD_TMPR_CSI_1P8_3P3 ¹ | | |
| | | VDD_USDHC1_VSELECT_1P8_3P3 | | | |
| Group 3 | 1.1 - 1.1v | 1.0v internal LDO's | 1.8v or 2.5v or 3.3v | | |
| | VDD_A35 ² | VDD_USB_OTG_1P0 | VDD_ENET0_1P8_2P5_3P3 | | |
| | VDD_GPU ² | | VDD_ENET0_VSELECT_1P8_2P5_3P3 | | |
| | | | VDD_ESAI_SPDIF_1P8_2P5_3P3 | | |

¹ Supply connection and Supply Group vary depending on use case. For use as tamper pin, it must be tied to the VDD_SNV5_LDO_1P8_CAP. If used as a CSI/SAI, it is tied to I/O supply.

² VDD_A35 and VDD_GPU can be combined with one power supply.

4.3 PLL electrical characteristics

4.3.1 PLLs of subsystems

i.MX 8QuadXPlus/8DualXPlus embeds a large number of PLLs to address clocking requirements of the various subsystems. These PLLs are controlled through the SCU and not directly by Cortex-A or Cortex-M4F processors. A software API shall be used by those processors to access the PLL settings. Additional PLLs are specific to high-performance interfaces. These are described in the following sections.

This table summarizes the PLLs controlled by the SCU.

Table 18. PLLs controlled by SCU

| Subsystem | PLL usage | Source clock | Locking range ¹ | | Lock freq. | Unit |
|-----------------------|------------------------------|--------------|----------------------------|-----------|--|------|
| | | | Min freq. | Max freq. | | |
| Cortex-A35 | Subsystem | 24 | 650 | 1300 | <ul style="list-style-type: none"> Overdrive: 1200 Nominal: 900² | |
| GPU | PLL #0: subsystem | 24 | 648 | 1344 | <ul style="list-style-type: none"> Overdrive: 700 Nominal: 744³ | MHz |
| | PLL #1: shaders | 24 | 648 | 1344 | <ul style="list-style-type: none"> Overdrive: : 850 Nominal: 744⁴ | MHz |
| DRC (DRAM Controller) | Subsystem | 24 | 1250 | 2500 | <ul style="list-style-type: none"> LPDDR4: 2400 DDR3L: 1866⁵ | MHz |
| DB (DRAM Block) | Subsystem | 24 | 650 | 1300 | 1200 | MHz |
| Display Controller 0 | PLL #0: subsystem | 24 | 650 | 1300 | 800 | MHz |
| | PLL #1: display clock #0 | 24 | 650 | 1300 | User-configurable | MHz |
| | PLL #2: display clock #1 | 24 | 650 | 1300 | User-configurable | MHz |
| Imaging | Subsystem | 24 | 650 | 1300 | 1200 | MHz |
| ADMA ⁶ | PLL #0: subsystem | 24 | 650 | 1300 | 1280 | MHz |
| | PLL #1: audio PLL #0 | 24 | 650 | 1300 | User-configurable | MHz |
| | PLL #2: audio PLL #1 | 24 | 650 | 1300 | User-configurable | MHz |
| | PLL #3: Parallel LCD display | 24 | 650 | 1300 | Pixel freq. $\times N$ | MHz |
| Connectivity | PLL #0: Subsystem | 24 | 650 | 1300 | 792 | MHz |
| | PLL #1: PHY | 24 | 650 | 1300 | 1000 | MHz |
| HSIO (High-speed I/O) | Subsystem | 24 | 650 | 1300 | 800 | MHz |
| LSIO (Low-speed I/O) | Subsystem | 24 | 650 | 1300 | 800 | MHz |

Table 18. PLLs controlled by SCU (continued)

| Subsystem | PLL usage | Source clock | Locking range ¹ | | Lock freq. | Unit |
|------------------------------|-------------------|--------------|----------------------------|-----------|------------|------|
| | | | Min freq. | Max freq. | | |
| Cortex-M4 | Subsystem | 24 | 650 | 1300 | 792 | MHz |
| VPU | PLL #0: subsystem | 24 | 650 | 1300 | 1200 | MHz |
| MIPI-DSI | Subsystem | 24 | 650 | 1300 | 864 | MHz |
| MIPI-CSI | Subsystem | 24 | 650 | 1300 | 720 | MHz |
| SCU (System Controller Unit) | Subsystem | 24 | 650 | 1300 | 1056 | MHz |

¹ Operating frequencies are limited to only those supported by the SCFW.

² 1200 MHz is used to generate the max frequency points, and 1000 MHz for the typical frequency point. See Table 10 to get associated voltages.

³ 700 MHz is used to generate the max frequency point, and 744 is used to generate the typical point (372 MHz).

⁴ 850 MHz is used to generate the max frequency point, and 744 is used to generate the typical point (372 MHz)

⁵ 2400 MHz is used to generate 1200 MHz when in LPDDR4 mode. 1866 MHz is used to generate 933 MHz when in DDR3L mode. See Table 10 to get associated voltages.

⁶ The audio PLLs support on-the-fly frequency changes for clock synchronization applications, 25 Hz steps, up to a maximum change of +/- 250 KHz is supported.

4.3.2 PLLs dedicated to specific interfaces

The following sections cover PLLs used for specific interfaces. Clock output frequency and clock output range refer to the output of the PLL. Additional clock dividers may be on the output path to divide the output frequency down to the targeted frequency. See the related sections in the reference manual for settings of these clock dividers.

4.3.2.1 Ethernet PLL

This PLL is controlled by the SCU.

Table 19. Ethernet PLL

| Parameter | Value | Unit |
|------------------------|-------|------|
| Reference clock | 24 | MHz |
| Clock output frequency | 1 | GHz |

4.3.2.2 USB 3.0 PLLs

USB 3.0 has two PLLs. One is embedded in Super-Speed PHY. The other one is embedded in the USB 2.0 OTG PHY that is part of the USB 3.0 interface.

Electrical characteristics

The table below describes the PLL embedded in the Super-Speed PHY.

Table 20. USB 2.0 PLL embedded in Super Speed PHY

| Parameter | Value | Unit |
|------------------------|-------|------|
| Reference clock | 24 | MHz |
| Clock output frequency | 5 | GHz |

The table below describes the PLL embedded in the USBOTG PHY.

Table 21. USB 2.0 PLL embedded in USBOTG PHY

| Parameter | Value | Unit |
|------------------------|-------|------|
| Reference clock | 24 | MHz |
| Clock output frequency | 480 | MHz |

4.3.2.3 USB 2.0 OTG PLLs

This PLL is embedded in the USB 2.0 OTG PHY (the one which is not part of the USB 3.0 feature).

Table 22. USB 2.0 OTG PLLs

| Parameter | Value | Unit |
|------------------------|-------|------|
| Reference clock | 24 | MHz |
| Clock output frequency | 480 | MHz |

4.3.2.4 PCIe PLLs

The PCIe interface has three PLLs:

- One is used to generate the single, common 100 MHz reference clock to each lane
- One Transmit and one Receive PLL in one lane

The table below shows the characteristics for the reference clock PLL.

Table 23. PCIe reference clock PLLs

| Parameter | Value | Unit | Comments |
|------------------------|-------|------|---|
| Reference clock | 24 | MHz | — |
| Clock output frequency | 100 | MHz | Used to generate internal 100 MHz reference clock to PCIe lanes |

The table below shows characteristics of the TX and RX PLLs used in each lane.

Table 24. PCIe Transmit and Receive PLLs

| Parameter | Value | Unit | Comments |
|--------------------|--------|------|--|
| Reference clock | 100 | MHz | From differential input clock pads or from internal PLL |
| Clock output range | 6 ~ 10 | GHz | PCIe gen3: 8GHz to get 8GHz baud clock PCIe gen2: 10GHz to get 5GHz baud clock PCIe gen3: 10GHz to get 2.5GHz baud clock |

4.3.2.5 MIPI-DSI/LVDS combo PLL

The table below shows characteristics of the PLL embedded in the MIPI-DSI/LVDS combo PHY.

Table 25. MIPI-DSI/LVDS combo PHY PLL

| Parameter | Value | Unit | Comments |
|--------------------|-------------|------|---|
| Reference clock | 24 | MHz | — |
| Clock output range | 0.75 ~ 1.05 | GHz | Dependent on targeted display configuration |

4.4 On-chip oscillators

4.4.1 OSC24M

This block integrates trimmable internal loading capacitors and driving circuitry. When combined with a suitable 24 MHz external quartz element, it can generate a low-jitter clock. The oscillator is powered from VDD_ANA1_1P8. The internal loading capacitors are trimmable to provide fine adjustment of the 24 MHz oscillation frequency. It is expected that customers burn appropriate trim values for the selected crystal and board parasitics.

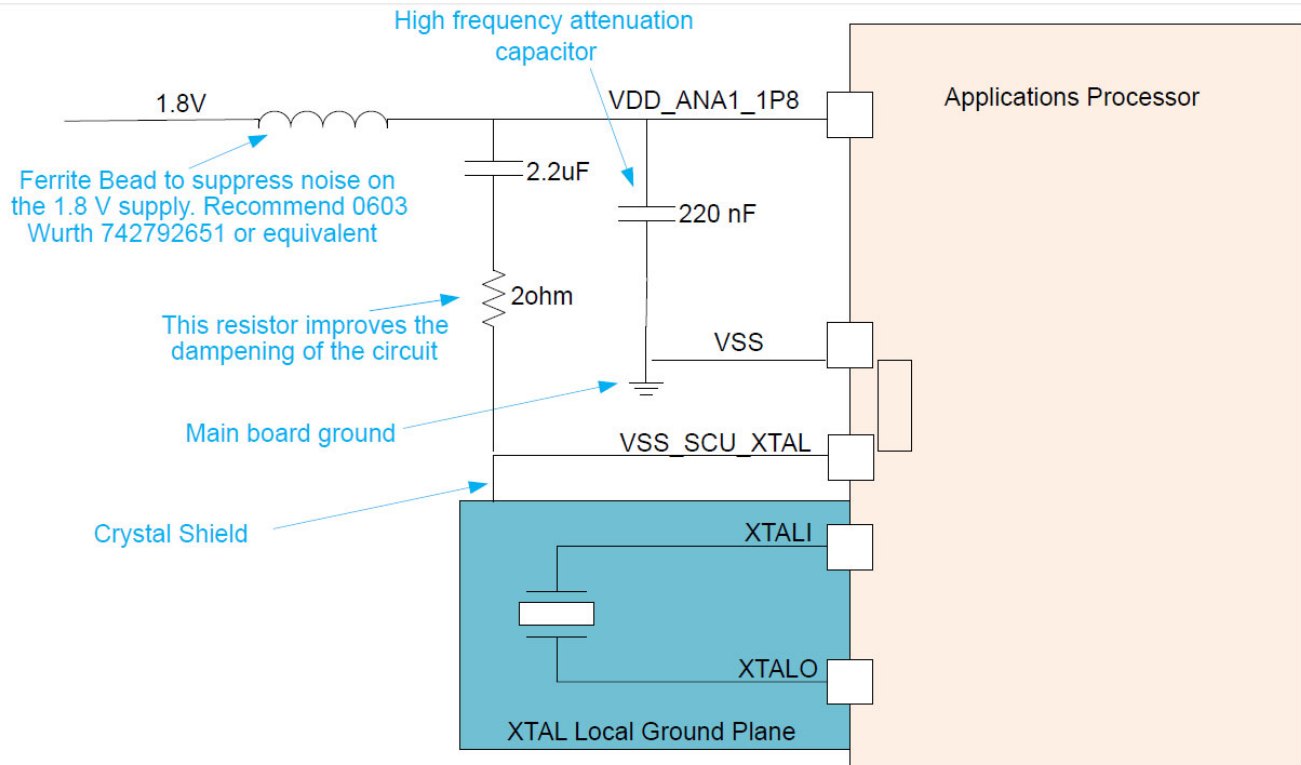

Figure 2. Normal Crystal Oscillation mode

Table 26. Crystal specifications

| Parameter description | Min | Typ | Max | Unit |
|------------------------|-----|-----|-----|------|
| Frequency ¹ | — | 24 | — | MHz |
| Clload ² | — | 18 | — | pF |
| Maximum drive level | 200 | — | — | μW |
| ESR | — | — | 60 | Ω |

¹ The required frequency accuracy is set by the serial interfaces utilized for a specific application and is detailed in the respective standard documents.

² Clload is the specification of the quartz element, not for the capacitors coupled to the quartz element.

4.4.2 OSC32K

This block implements an internal amplifier, trimmable load capacitors and a bias network that when combined with a suitable quartz crystal implements a low power oscillator.

Additionally, if the clock monitor determines that the 32KHz oscillation is not present, then the source of the 32 KHz clock will automatically switch to the internal relaxation oscillator of lesser frequency accuracy.

CAUTION

The internal ring oscillator is not meant to be used in customer applications, due to gross frequency variation over wafer processing, temperature, and supply voltage. These variations will cause timing issues to many different circuits that use the internal ring oscillator for reference; and, if this timing is critical, application issues will occur. To prevent application issues, it is recommended to only use an external crystal or an accurate external clock. If this recommendation is not followed, NXP cannot guarantee full compliance of any circuit using this clock. The OSC32K runs from VDD_SNVS_LDO_1P8_CAP, which is regulated from VDD_SNVS. The target battery/voltage range is 2.8 to 4.2 V for VDD_SNVS, with a regulated output of approximately 1.75 V.

Table 27. OSC32K main characteristics

| Parameter | Min | Typ | Max | Comments |
|----------------------------------|-----|---|----------------|--|
| Fosc | — | 32.768 kHz | — | This frequency is nominal and determined mainly by the crystal selected. 32.0 KHz is also supported. |
| Current consumption | — | <ul style="list-style-type: none"> • xtal oscillator mode: 5 μA • 32K internal oscillator mode: 10 μA | — | These values are for typical process and room temperature. Values will be updated after silicon characterization. |
| Bias resistor | — | 200 M Ω | — | This the integrated bias resistor that sets the amplifier into a high gain state. Any leakage through the ESD network, external board leakage, or even a scope probe that is significant relative to this value will debias the amplifier. The debiasing will result in low gain, and will impact the circuit's ability to start up and maintain oscillations. |
| Target Crystal Properties | | | | |
| Cload | — | 10 pF | — | Usually crystals can be purchased tuned for different Cloads. This Cload value is typically 1/2 of the capacitances realized on the PCB on either side of the quartz. A higher Cload will decrease oscillation margin, but increases current oscillating through the crystal. |
| ESR | — | 50 k Ω | 100 k Ω | Equivalent series resistance of the crystal. Choosing a crystal with a higher value will decrease the oscillating margin. |

Table 28. External input clock for OSC32K

| | Min | Typ | Max | Unit | Notes |
|---------------------------|-----|--------------|----------------------|------|-------|
| Frequency | — | 32.768 or 32 | — | kHz | — |
| V _{pp} RTC_XTALI | 700 | — | VDD_SNVS_LDO_1P8_CAP | mV | 1,2,3 |
| Rise/fall time | — | — | — | ns | 4 |

Electrical characteristics

- ¹ The external clock is fed into the chip from the RTC_XTALI pin; the RTC_XTALO pin should be left floating.
- ² The parameter specified here is a peak-to-peak value and V_{IH}/V_{IL} specifications do not apply.
- ³ The voltage applied on RTC_XTALI must be within the range of VSS to VDD_SNV5_LDO_1P8_CAP.
- ⁴ The rise/fall time of the applied clock are not strictly confined.

4.5 I/O DC Parameters

This section includes the DC parameters of the following I/O types:

- XTALI and RTC_XTALI (clock inputs) DC parameters
- General Purpose I/O (GPIO) DC parameters

NOTE

The term ‘OVDD’ in this section refers to the associated supply rail of an input or output.

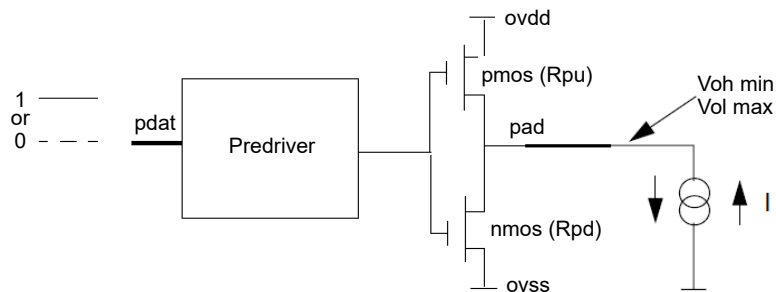

Figure 3. Circuit for Parameters Voh and Vol for I/O Cells

4.5.1 XTALI and RTC_XTALI (Clock Inputs) DC Parameters

For RTC_XTALI, V_{IH}/V_{IL} specifications do not apply. The high and low levels of the applied clock on this pin are not strictly defined, as long as the input's peak-to-peak amplitude meet the requirements and the input's voltage value does not exceed the limits.

4.5.2 General-purpose I/O (GPIO) DC parameters

4.5.2.1 Tri-voltage GPIO DC parameters

The following tables show tri-voltage 1.8V, 2.5 V, and 3.3 V DC parameters, respectively, for GPIO pads. These parameters are guaranteed per the operating ranges in [Table 10](#), unless otherwise noted.

Table 29. Tri-voltage 1.8 V GPIO DC parameters¹

| Parameter | Symbol | Test Conditions | Min | Max | Units |
|--|-------------------|--|--------------|--------------|-------|
| High-level output voltage ^{2,3} | V _{OH} | I _{OH} = -0.1mA DSE=1 | 0.8 × OVDD | — | V |
| | | I _{OH} = -2mA DSE=0 | | | |
| Low-level output voltage ^{2,3} | V _{OL} | I _{OL} = -0.1mA DSE=1 | — | 0.125 × OVDD | V |
| | | I _{OL} = -2mA DSE=0 | | | |
| High-Level input voltage ^{2,4} | V _{IH} | — | 0.625 × OVDD | OVDD | V |
| Low-Level input voltage | V _{IL} | — | 0 | 0.25 × OVDD | V |
| Pull-up resistance | R _{PU} | V _{IN} =0V (Pullup Resistor) PUN = "L", PDN = "H" | 15 | 50 | kΩ |
| Pull-down resistance | R _{DOWN} | V _{IN} =OVDD (Pulldown Resistor) PUN = "H", PDN = "L" | 15 | 50 | kΩ |
| Input current (no PU/PD) | I _{IN} | V _I = 0, V _I = OVDD PUN = "H", PDN = "H" | -1 | 1 | μA |

¹ For tri-voltage I/O, the associated IOMUXD compensation control register PSW_OVR and COMP bits must be set correctly. For 1.8 or 3.3 V operation, the SCFW API must be used to set PSW_OVR = 0b0 and COMP=0b000. For 2.5 V operation, PSW_OVR = 0b1 and COMP = 0b010.

² Overshoot and undershoot conditions (transitions above OVDD and below GND) on switching pads must be held below 0.3 V, and the duration of the overshoot/undershoot must not exceed 10% of the system clock cycle. Overshoot/undershoot must be controlled through printed circuit board layout, transmission line impedance matching, signal line termination, or other methods. Noncompliance to this specification may affect device reliability or cause permanent damage to the device. (OVDD is the I/O Supply)

³ DSE is the setting of the PDRV register. High Drive mode is recommended for 3v3 and 2v5 modes. Low Drive mode is recommended for 1v8 mode.

⁴ To maintain a valid level, the transition edge of the input must sustain a constant slew rate (monotonic) from the current DC level through to the target DC level, V_{IL} or V_{IH}. Monotonic input transition time is from 0.1 ns to 1 ns.

Table 30. Tri-voltage 2.5 V GPIO DC parameters¹

| Parameter | Symbol | Test Conditions | Min | Max | Units |
|--|-----------------|---|--------------|--------------|-------|
| High-level output voltage ^{2,3} | V _{OH} | I _{OH} = -2mA DSE=0 | 0.8 × OVDD | — | V |
| Low-level output voltage ^{2,3} | V _{OL} | I _{OL} = -2mA DSE=0 | — | 0.125 × OVDD | V |
| High-Level input voltage ^{2,4} | V _{IH} | — | 0.625 × OVDD | OVDD | V |
| Low-Level input voltage | V _{IL} | — | 0 | 0.25 × OVDD | V |
| Pull-up resistance | R _{PU} | V _{IN} =0V (Pullup Resistor) PUN = "L", PDN = "H" | 10 | 100 | kΩ |

Electrical characteristics

Table 30. Tri-voltage 2.5 V GPIO DC parameters¹ (continued)

| Parameter | Symbol | Test Conditions | Min | Max | Units |
|--------------------------|------------|---|-----|-----|-----------|
| Pull-down resistance | R_{DOWN} | $V_{IN}=OVDD$ (Pulldown Resistor) PUN = "H", PDN = "L" | 10 | 100 | $k\Omega$ |
| Input current (no PU/PD) | I_{IN} | $V_I = 0, V_I = OVDD$ PUN = "H", PDN = "H" | -1 | 1 | μA |

- ¹ For tri-voltage I/O, the associated IOMUXD compensation control register PSW_OVR and COMP bits must be set correctly. For 1.8 or 3.3 V operation, the SCFW API must be used to set PSW_OVR = 0b0 and COMP=0b000. For 2.5 V operation, PSW_OVR = 0b1 and COMP = 0b010.
- ² Overshoot and undershoot conditions (transitions above OVDD and below GND) on switching pads must be held below 0.3 V, and the duration of the overshoot/undershoot must not exceed 10% of the system clock cycle. Overshoot/undershoot must be controlled through printed circuit board layout, transmission line impedance matching, signal line termination, or other methods. Noncompliance to this specification may affect device reliability or cause permanent damage to the device. (OVDD is the I/O supply.)
- ³ DSE is the setting of the PDRV register. High Drive mode is recommended for 3v3 and 2v5 modes. Low Drive mode is recommended for 1v8 mode.
- ⁴ To maintain a valid level, the transition edge of the input must sustain a constant slew rate (monotonic) from the current DC level through to the target DC level, V_{IL} or V_{IH} . Monotonic input transition time is from 0.1 ns to 1 ns.

Table 31. Tri-voltage 3.3 V GPIO DC parameters¹

| Parameter | Symbol | Test Conditions | Min | Max | Units |
|---|------------|---|---------------------|---------------------|-----------|
| High-level output voltage ^{2,3} | V_{OH} | $I_{OH} = -0.1mA$ 4DSE=1 | $0.8 \times OVDD$ | | V |
| | | $I_{OH} = -2mA$ 4DSE=0 | | | |
| Low-level output voltage ^{2,3} | V_{OL} | $I_{OL} = -0.1mA$ 4DSE ³ =1 | — | $0.125 \times OVDD$ | V |
| | | $I_{OL} = -2mA$ 4DSE=0 | | | |
| High-Level input voltage ^{2,4,3} | V_{IH} | — | $0.725 \times OVDD$ | OVDD | V |
| Low-Level input voltage | V_{IL} | — | 0 | $0.25 \times OVDD$ | V |
| Pull-up resistance | RPU | $V_{IN}=0V$ (Pullup Resistor) PUN = "L", PDN = "H" | 10 | 100 | $k\Omega$ |
| Pull-down resistance | R_{DOWN} | $V_{IN}=OVDD$ (Pulldown Resistor) PUN = "H", PDN = "L" | 10 | 100 | $k\Omega$ |
| Input current (no PU/PD) | IIN | $V_I = 0, V_I = OVDD$ PUN = "H", PDN = "H" | -2 | 2 | μA |

- ¹ For tri-voltage I/O, the associated IOMUXD compensation control register PSW_OVR and COMP bits must be set correctly. For 1.8 or 3.3 V operation, the SCFW API must be used to set PSW_OVR = 0b0 and COMP=0b000. For 2.5 V operation, PSW_OVR = 0b1 and COMP = 0b010.

- ² Overshoot and undershoot conditions (transitions above OVDD and below GND) on switching pads must be held below 0.3 V, and the duration of the overshoot/undershoot must not exceed 10% of the system clock cycle. Overshoot/undershoot must be controlled through printed circuit board layout, transmission line impedance matching, signal line termination, or other methods. Noncompliance to this specification may affect device reliability or cause permanent damage to the device. (OVDD is the I/O Supply.)
- ³ DSE is the setting of the PDRV register. High Drive mode recommended for 3v3 and 2v5 modes. Low Drive mode is recommended for 1v8 mode.
- ⁴ To maintain a valid level, the transition edge of the input must sustain a constant slew rate (monotonic) from the current DC level through to the target DC level, V_{IL} or V_{IH} . Monotonic input transition time is from 0.1 ns to 1 ns.

4.5.2.2 Dual-voltage GPIO DC parameters

The following two tables show dual-voltage 1.8 V and 3.3 V DC parameters, respectively, for GPIO pads. These parameters are guaranteed per the operating ranges in [Table 10](#), unless otherwise noted.

Table 32. Dual-voltage 1.8 V GPIO DC parameters

| Parameter | Symbol | Test Conditions | Min | Max | Units |
|--|------------|--|-------------------------|-------------------------|------------|
| High-level output voltage ^{1,2} | V_{OH} | Ioh= -0.1mA DSE=1 | $0.8 \times OVDD$ | — | V |
| | | Ioh= -2mA DSE=0 | | | |
| Low-level output voltage ^{1,2} | V_{OL} | Iol= -0.1mA DSE=1 | — | $0.125 \times OVD$ D | V |
| | | Iol= -2mA DSE=0 | | | |
| High-Level input voltage ^{1,3} | V_{IH} | — | $0.625 \times OVD$ D | OVDD | V |
| Low-Level input voltage | V_{IL} | — | 0 | $0.25 \times OVDD$ | V |
| Pull-up resistance | R_{PU} | Vin=0 V (Pullup Resistor) PUN = "L", PDN = "H" | 15 | 50 | k Ω |
| Pull-down resistance | R_{down} | Vin=OVDD (Pulldown Resistor) PUN = "H", PDN = "L" | 15 | 50 | k Ω |
| Input current (no PU/PD) | I_{IN} | $V_I = 0$, $V_I = OVDD$ PUN = "H", PDN = "H" | -1 | 1 | μA |

- ¹ Overshoot and undershoot conditions (transitions above OVDD and below GND) on switching pads must be held below 0.3 V, and the duration of the overshoot/undershoot must not exceed 10% of the system clock cycle. Overshoot/undershoot must be controlled through printed circuit board layout, transmission line impedance matching, signal line termination, or other methods. Noncompliance to this specification may affect device reliability or cause permanent damage to the device. (OVDD is the IO Supply.)
- ² DSE is the setting of the PDRV register. High Drive mode is recommended for SD standard (3v3 mode) and MMC standard (1v8/3v3 modes). Low Drive mode is recommended for SD standard (1v8 mode).
- ³ To maintain a valid level, the transition edge of the input must sustain a constant slew rate (monotonic) from the current DC level through to the target DC level, V_{IL} or V_{IH} . Monotonic input transition time is from 0.1 ns to 1 ns.

Table 33. Dual-voltage 3.3 V GPIO DC parameters

| Parameter | Symbol | Test Conditions | Min | Max | Units |
|--|-------------------|---|--------------|--------------|-------|
| High-level output voltage ^{1,2} | V _{OH} | I _{oh} = -0.1mA DSE=1 | 0.8 × OVDD | — | V |
| | | I _{oh} = -2mA DSE=0 | | | |
| Low-level output voltage ^{1,2} | V _{OL} | I _{ol} = -0.1mA DSE=1 | — | 0.125 × OVDD | V |
| | | I _{ol} = -2mA DSE=0 | | | |
| High-Level input voltage ^{1,3} | V _{IH} | — | 0.725 × OVDD | OVDD | V |
| Low-Level input voltage | V _{IL} | — | 0 | 0.25 × OVDD | V |
| Pull-upresistance | R _{PU} | V _{in} =0V (Pullup Resistor) PUN = "L", PDN = "H" | 10 | 100 | kΩ |
| Pull-down resistance | R _{down} | V _{in} =OVDD(Pulldown Resistor) PUN = "H", PDN = "L" | 10 | 100 | kΩ |
| Input current (no PU/PD) | I _{IN} | V _I = 0, V _I = OVDD PUN = "H", PDN = "H" | -2 | 2 | μA |

¹ Overshoot and undershoot conditions (transitions above OVDD and below GND) on switching pads must be held below 0.3 V, and the duration of the overshoot/undershoot must not exceed 10% of the system clock cycle. Overshoot/undershoot must be controlled through printed circuit board layout, transmission line impedance matching, signal line termination, or other methods. Noncompliance to this specification may affect device reliability or cause permanent damage to the device. (OVDD is the I/O Supply.)

² DSE is the setting of the PDRV register. High Drive mode is recommended for SD standard (3v3 mode) and MMC standard (1v8/3v3 modes). Low Drive mode is recommended for SD standard (1v8 mode).

³ To maintain a valid level, the transition edge of the input must sustain a constant slew rate (monotonic) from the current DC level through to the target DC level, V_{IL} or V_{IH}. Monotonic input transition time is from 0.1 ns to 1 ns.

4.5.2.3 Single-voltage GPIO DC parameters

Table 34 and Table 35 show single-voltage 1.8 V and 3.3 V DC parameters, respectively, for GPIO pads. These parameters are guaranteed per the operating ranges in Table 10 unless otherwise noted.

Table 34. Single-voltage 1.8 V GPIO DC parameters

| Parameter | Symbol | Test Conditions | Min | Max | Units |
|--|-----------------|--|------------|-----|-------|
| High-level output voltage ^{1,2} | V _{OH} | I _{OH} = -0.1mA DSE = 000 or 001 | OVDD × 0.8 | — | V |
| | | I _{OH} = -2mA DSE = 010 or 011 | | | |
| | | I _{OH} = -4mA DSE = 100 to 110 | | | |

Table 34. Single-voltage 1.8 V GPIO DC parameters (continued)

| Parameter | Symbol | Test Conditions | Min | Max | Units |
|---|--------------|--|--------------------|--------------------|---------------|
| Low-level output voltage ^{1,2} | V_{OL} | $I_{OL} = 0.1\text{mA}$ DSE = 000 or 001 | — | $OVDD \times 0.2$ | V |
| | | $I_{OL} = 2\text{mA}$ DSE = 010 or 011 | | | |
| | | $I_{OL} = 4\text{mA}$ DSE = 100 to 110 | | | |
| High-Level input voltage ^{2,3} | V_{IH} | — | $0.65 \times OVDD$ | OVDD | V |
| Low-Level input voltage ^{2,3} | V_{IL} | — | 0 | $0.35 \times OVDD$ | V |
| Pull-up resistance | R_{PU} | $V_{in}=0\text{V}$ (Pullup Resistor) PUN = "L", PDN = "H" | 20 | 90 | k Ω |
| Pull-down resistance | R_{down} | $V_{in}=OVDD$ (Pulldown Resistor) PUN = "H", PDN = "L" | 20 | 90 | k Ω |
| Input current (no PU/PD) | I_{IN} | $V_I = 0, V_I = OVDD$ PUN = "H", PDN = "H" | -5 | 5 | μA |
| Keeper Circuit Resistance | R_{Keeper} | $V_I = .3 \times OVDD, V_I = .7 \times OVDD$ PUN = "L", PDN = "L" | 20 | 90 | k Ω |

¹ As programmed in the associated IOMUX (DSE field) register.

² Overshoot and undershoot conditions (transitions above OVDD and below GND) on switching pads must be held below 0.3 V, and the duration of the overshoot/undershoot must not exceed 10% of the system clock cycle. Overshoot/undershoot must be controlled through printed circuit board layout, transmission line impedance matching, signal line termination, or other methods. Noncompliance to this specification may affect device reliability or cause permanent damage to the device. (OVDD is the IO supply.)

³ To maintain a valid level, the transition edge of the input must sustain a constant slew rate (monotonic) from the current DC level through to the target DC level, V_{IL} or V_{IH} . Monotonic input transition time is from 0.1 ns to 1 ns.

Table 35. Single-voltage 3.3 V GPIO DC parameters

| Parameter | Symbol | Test Conditions | Min | Max | Units |
|--|----------|---|--------------------|--------------------|------------|
| High-level output voltage ^{1,2} | V_{OH} | $I_{OH} = -0.1\text{mA}$ DSE = 00 or 01 | $0.8 \times OVDD$ | — | V |
| | | $I_{OH} = -2\text{mA}$ DSE = 10 or 11 | | | |
| Low-level output voltage ^{1,2} | V_{OL} | $I_{OL} = 0.1\text{mA}$ DSE = 00 or 01 | — | $0.2 \times OVDD$ | V |
| | | $I_{OL} = 2\text{mA}$ DSE = 10 or 11 | | | |
| High-Level input voltage ^{2,3} | V_{IH} | — | $0.75 \times OVDD$ | OVDD | V |
| Low-Level input voltage ^{2,3} | V_{IL} | — | 0 | $0.25 \times OVDD$ | V |
| Pull-upresistance | R_{PU} | $V_{in}=0\text{ V}$ (Pullup Resistor) PUN = "L", PDN = "H" | 20 | 90 | k Ω |

Electrical characteristics

Table 35. Single-voltage 3.3 V GPIO DC parameters (continued)

| Parameter | Symbol | Test Conditions | Min | Max | Units |
|---------------------------|--------------|--|-----|-----|-----------|
| Pull-down resistance | R_{down} | $V_{in}=OVDD$ (Pulldown Resistor) PUN = "H", PDN = "L" | 20 | 90 | $k\Omega$ |
| Input current (no PU/PD) | I_{IN} | $V_I = 0, V_I = OVDD$ PUN = "H", PDN = "H" | -5 | 5 | μA |
| Keeper Circuit Resistance | R_{Keeper} | $V_I = .3xOVDD, V_I = .7x OVDD$ PUN = "L", PDN = "L" | 20 | 90 | $k\Omega$ |

¹ As programmed in the associated IOMUX (DSE field) register.

² Overshoot and undershoot conditions (transitions above OVDD and below GND) on switching pads must be held below 0.3 V, and the duration of the overshoot/undershoot must not exceed 10% of the system clock cycle. Overshoot/undershoot must be controlled through printed circuit board layout, transmission line impedance matching, signal line termination, or other methods. Noncompliance to this specification may affect device reliability or cause permanent damage to the device. (OVDD is the IO supply.)

³ To maintain a valid level, the transition edge of the input must sustain a constant slew rate (monotonic) from the current DC level through to the target DC level, V_{IL} or V_{IH} . Monotonic input transition time is from 0.1 ns to 1 ns.

4.5.3 DDR I/O DC parameters

4.5.3.1 LPDDR4 mode I/O DC parameters

These parameters are guaranteed per the operating ranges in [Table 10](#) unless otherwise noted.

Table 36. LPDDR4 DC parameters

| Parameter | Symbol | Test Conditions | Min | Max | Units |
|--|--------------|--|----------------------|----------------------|---------|
| High-level output voltage ¹ | V_{OH} | Out Drive = All setting (40,48,60,80,120,240) unterminated outputs loaded with 1pF capacitor load | $0.9 \times V_{DDQ}$ | — | V |
| Low-level output voltage ¹ | V_{OL} | Out Drive = All setting (40,48,60,80,120,240) unterminated outputs loaded with 1pF capacitor load | — | $0.1 \times V_{DDQ}$ | V |
| Input current (no ODT) | I_{IN} | $V_I = VSSQ, V_I = VDDQ$ | -2 | 2 | μA |
| DC High-Level input voltage | V_{IH_DC} | — | $VREF + 0.1$ | $VDDQ$ | V |
| DC Low-Level input voltage | V_{IL_DC} | — | $VSSQ$ | $VREF - 0.1$ | V |

¹ Maximum peak amplitude allowed for overshoot and undershoot area = 0.35 V. Maximum overshoot area above VDD/VDDQ 0.8 V-ns; maximum undershoot area below VSS/VSSQ 0.8 V-ns.

4.5.3.2 DDR3L mode I/O DC parameters

Table 37. SSTL DDR3L DC parameters

| Parameter | Symbol | Test Conditions | Min | Max | Units |
|--|--------------|---|----------------------|----------------------|----------|
| DC High-level output voltage ¹ | V_{OH} | Out Drive = All setting (40,60,120) unterminated outputs loaded with 1pF capacitor load | $0.8 \times V_{DDQ}$ | — | V |
| DC Low-level output voltage ¹ | V_{OL} | Out Drive = All setting (40,60,120) unterminated outputs loaded with 1pF capacitor load | — | $0.2 \times V_{DDQ}$ | V |
| Input termination resistance (ODT) to VDDQ/2 | RTT | 40 Ω setting | 36 | 44 | Ω |
| | | 60 Ω setting | 54 | 66 | |
| | | 120 Ω setting | 100 | 140 | |
| Input current (no ODT) | I_{IN} | $V_I = V_{SSQ}, V_I = V_{DDQ}$ | -2 | 2 | μA |
| DC High-Level input voltage | V_{IH_DC} | | VREF + 0.09 | VDDQ | V |
| DC Low-Level input voltage | V_{IL_DC} | | VSSQ | VREF - 0.09 | V |

¹ Maximum peak amplitude allowed for overshoot and undershoot area = 0.35 V. Maximum overshoot area above VDD/VDDQ 0.8 V-ns; maximum undershoot area below VSS/VSSQ 0.8 V-ns.

4.6 I/O AC Parameters

The GPIO and DDR I/O load circuit and output transition time waveforms are shown in Figure 4 and Figure 5.

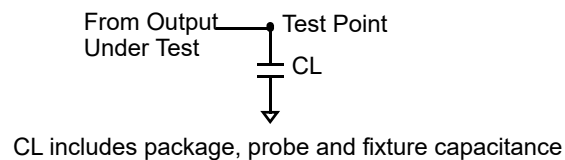

Figure 4. Load Circuit for Output

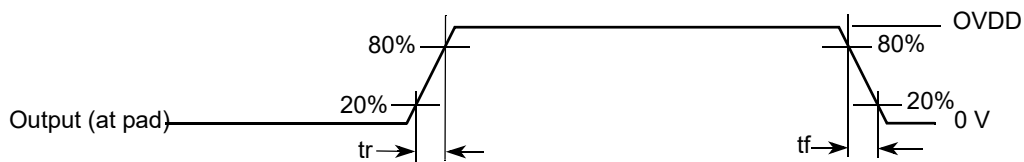

Figure 5. Output Transition Time Waveform

4.6.1 General Purpose I/O (GPIO) AC Parameters

Table 38. General Purpose I/O AC Parameters¹

| Symbol | Parameter | Test Condition | Min | Typ | Max | Unit |
|---|-------------------|--|-----|-----|------|------|
| 1.8 V application² | | | | | | |
| f _{max} | Maximum frequency | Load = 21 pF (PDRV = H, high drive, Type A, 33 Ω) | — | — | 208 | MHz |
| | | Load = 15 pF (PDRV = L, low drive, Type B, 50 Ω) | | | | |
| t _r | Rise time | Measured between V _{OL} and V _{OH} | 0.4 | — | 1.32 | ns |
| t _f | Fall time | Measured between V _{OH} and V _{OL} | 0.4 | — | 1.32 | ns |
| Driver 3.3 V application³ | | | | | | |
| f _{max} | Maximum frequency | Load = 30 pF | — | — | 52 | MHz |
| t _r | Rise time | Measured between V _{OL} and V _{OH} | — | — | 3 | ns |
| t _f | Fall time | Measured between V _{OH} and V _{OL} | — | — | 3 | ns |

¹ All output I/O specifications are guaranteed for Accurate mode of the compensation cell operation. This is applicable for both DC and AC specifications.

² All timing specifications in 1.8 V application are valid for High Drive mode (PDRV = H). In Low Drive mode (PDRV = L), the driver is functional.

³ All timing specifications in 3.3 V application are valid for Type B driver only. In Type A, the driver is functional.

Table 39. Dynamic input characteristics

| Symbol | Parameter | Condition ^{1,2} | Min | Max | Unit |
|--|------------------------------|--|--------|---------------|------|
| Dynamic Input Characteristics for 3.3 V Application | | | | | |
| f _{op} | Input frequency of operation | — | — | 52 | MHz |
| INPSL | Slope of input signal at I/O | Measured between 10% to 90% of the I/O swing | — | 3.5 | ns |
| IOMAX | High level input voltage | — | — | 3.3 V + 0.3 V | V |
| IOMIN | Low level input voltage | — | -0.3 V | — | |
| Dynamic Input Characteristics for 1.8 V Application | | | | | |
| f _{op} | Input frequency of operation | — | — | 208 | MHz |
| INPSL | Slope of input signal at I/O | Measured between 10% to 90% of the I/O swing | — | 1.5 | ns |
| IOMAX | High level input voltage | — | — | 1.8 V + 0.3 V | V |
| IOMIN | Low level input voltage | — | -0.3 V | — | |

¹ For all supply ranges of operation.

² The dynamic input characteristic specifications are applicable for the digital bidirectional cells.

4.7 Output Buffer Impedance Parameters

This section defines the I/O impedance parameters for the following I/O types:

- General Purpose I/O (GPIO) output buffer impedance
- Double Data Rate I/O (DDR) output buffer impedance for LPDDR4 and DDR3L modes

NOTE

GPIO and DDR I/O output driver impedance is measured with “long” transmission line of impedance Z_{tl} attached to I/O pad and incident wave launched into transmission line. R_{pu}/R_{pd} and Z_{tl} form a voltage divider that defines specific voltage of incident wave relative to OVDD. Output driver impedance is calculated from this voltage divider (see [Figure 6](#)).

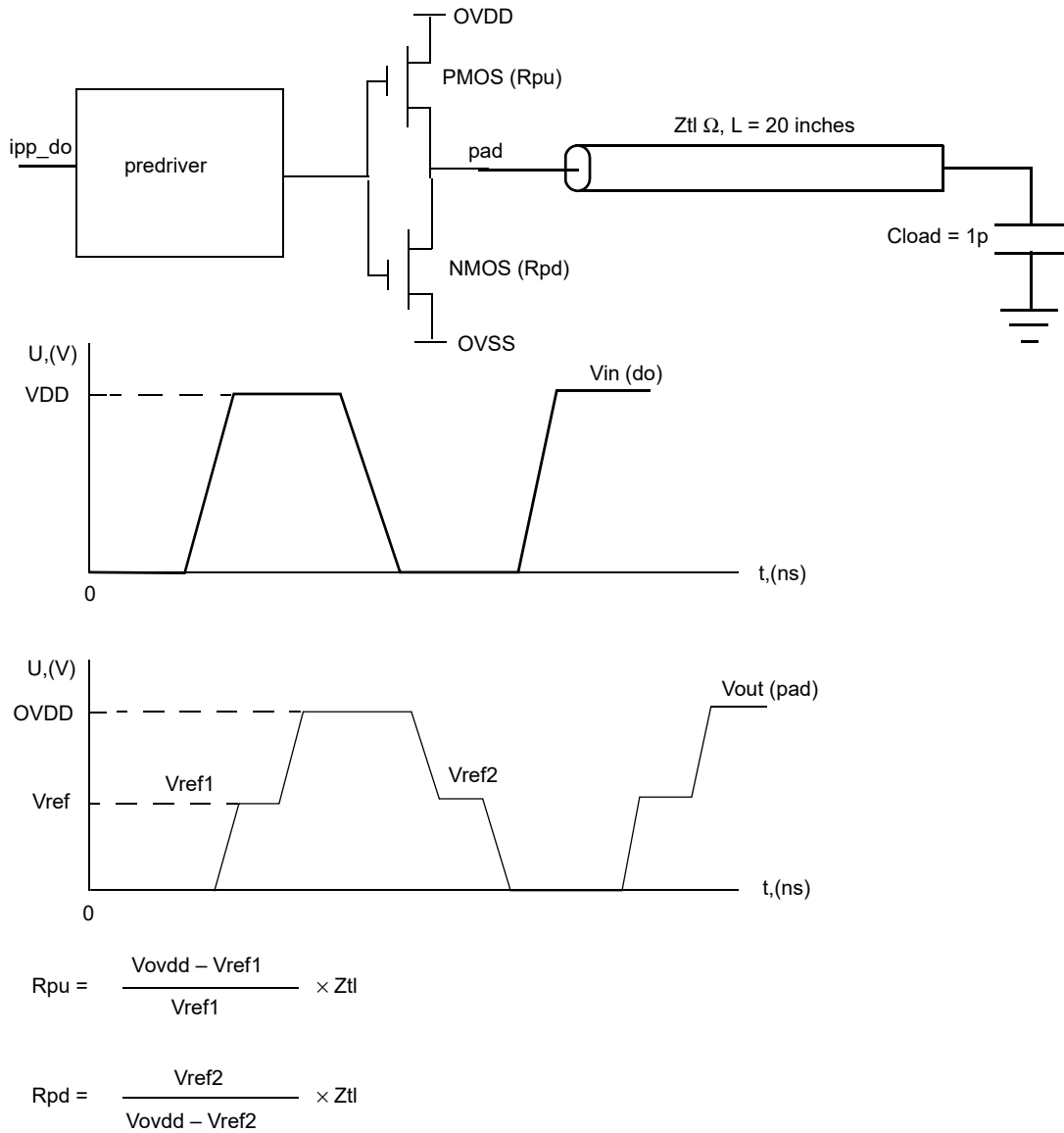

Figure 6. Impedance Matching Load for Measurement

4.7.1 GPIO output buffer impedance

4.7.1.1 Tri-voltage GPIO output buffer impedance

Table 40. Tri-voltage 1.8 V GPIO output impedance DC parameters

| Parameter | Symbol | Test conditions | Typical | Units |
|------------------|--------|--------------------|---------|----------|
| Output impedance | Z_O | ¹ DSE=0 | 33 | Ω |
| Output impedance | Z_O | ¹ DSE=1 | 50 | Ω |

¹ As programmed in the associated IOMUX (PDRV field) register.

Table 41. Tri-voltage 2.5 V GPIO output impedance DC parameters

| Parameter | Symbol | Test conditions | Typical | Units |
|------------------|--------|--------------------|---------|----------|
| Output impedance | Z_O | ¹ DSE=0 | 25 | Ω |
| Output impedance | Z_O | ¹ DSE=1 | 33 | Ω |

¹ As programmed in the associated IOMUX (PDRV field) register.

Table 42. Tri-voltage 3.3 V GPIO output impedance DC parameters

| Parameter | Symbol | Test conditions | Typical | Units |
|------------------|--------|--------------------|---------|----------|
| Output impedance | Z_O | ¹ DSE=0 | 25 | Ω |
| Output impedance | Z_O | ¹ DSE=1 | 37 | Ω |

¹ As programmed in the associated IOMUX (PDRV field) register.

4.7.1.2 Dual-voltage GPIO output buffer impedance

Table 43. Dual-voltage 1.8 V GPIO output impedance DC parameters

| Parameter | Symbol | Test conditions | Typical | Units |
|------------------|--------|--------------------|---------|----------|
| Output impedance | Z_O | ¹ DSE=0 | 33 | Ω |
| Output impedance | Z_O | ¹ DSE=1 | 50 | Ω |

¹ 'As programmed in the associated IOMUX (PDRV field) register.

Table 44. Dual-voltage 3.3 V GPIO output impedance DC parameters

| Parameter | Symbol | Test conditions | Typical | Units |
|------------------|--------|--------------------|---------|----------|
| Output impedance | Z_O | ¹ DSE=0 | 25 | Ω |
| Output impedance | Z_O | ¹ DSE=1 | 37 | Ω |

¹ As programmed in the associated IOMUX (PDRV field) register.

4.7.1.3 Single-voltage 1.8 V GPIO output buffer drive strength

The following table shows the GPIO output buffer drive strength (OVDD 1.8 V).

Table 45. Single-voltage GPIO 1.8 V output impedance DC parameters

| Parameter | Symbol | Test conditions | Typical | Units |
|------------------|--------|----------------------|---------|----------|
| Output impedance | Z_O | ¹ DSE=000 | 200 | Ω |
| | | ¹ DSE=001 | 100 | |
| | | ¹ DSE=010 | 55 | |
| | | ¹ DSE=011 | 40 | |
| | | ¹ DSE=100 | 30 | |
| | | ¹ DSE=101 | 24 | |
| | | ¹ DSE=110 | 20 | |
| | | ¹ DSE=111 | 18 | |

¹ As programmed in the associated IOMUX (DSE field) register.

4.7.1.4 Single-voltage 3.3 V GPIO output buffer drive strength

The following table shows the GPIO output buffer drive strength (OVDD 3.3 V).

Table 46. Single-voltage GPIO 3.3 V output impedance DC parameters

| Parameter | Symbol | Test conditions | Typical | Units |
|------------------|--------|---------------------|---------|----------|
| Output impedance | Z_O | ¹ DSE=00 | 400 | Ω |
| | | ¹ DSE=01 | 200 | |
| | | ¹ DSE=10 | 100 | |
| | | ¹ DSE=11 | 50 | |

¹ As programmed in the associated IOMUX (DSE field) register.

4.7.2 DDR I/O output buffer impedance

The following tables show DDR3L and LPDDR4 I/O output buffer impedance of the device.

The ZQ Calibration cell uses a single register (ZQnPR0) to determine the target output buffer impedances of the pull-up driver and the pull-down driver, as well as the target on-die termination impedance. The resulting calibration setting is then applied to all DDR pads within the PHY complex.

Table 47 and Table 49 show, respectively, the recommended ZQnPR0 field settings for the DDR3L and LPDDR4 I/Os to achieve the desired output buffer impedances. Table 48 and Table 50 show, respectively, the recommended ZQnPR0 field settings for the DDR3L and LPDDR4 I/Os to achieve the desired ODT settings.

Table 47. LPDDR4 I/O output buffer impedance

| Parameter | Typical | | | |
|---|-----------------------------|-------------|-----------------------------|--------------|
| | ZQnPR0 ZPROG_ASYM_PU_DRV | Impedance | ZQnPR0 ZPROG_ASYM_PD_DRV | Impedance |
| Recommended combinations for DQ /CA pins | 5 | 80 Ω | 3 | 120 Ω |
| | 7 | 60 Ω | 5 | 80 Ω |
| | 9 | 48 Ω | 7 | 60 Ω |
| | 11 | 40 Ω | 9 | 48 Ω |

Table 48. LPDDR4 I/O on-die termination impedance

| Parameter | Typical Impedance | ZQnPR0. ZPROG_HOST_ODT |
|--|----------------------|------------------------|
| Recommended combinations for DQ/CA pins | 120.0 Ω | 3 |
| | 80.0 Ω | 5 |
| | 60.0 Ω | 7 |
| | 48.0 Ω | 9 |
| | 40.0 Ω | 11 |

Table 49. DDR3L I/O output buffer impedance

| Parameter | Typical Impedance | ZQnPR0. ZPROG_ASYM_PU_DRV | ZQnPR0. ZPROG_ASYM_PD_DRV |
|--|----------------------|---------------------------|---------------------------|
| Recommended combinations for DQ/CA pins | 48.0 Ω | 9 | 9 |
| | 40.0 Ω | 11 | 11 |
| | 34.3 Ω | 13 | 13 |

Table 50. DDR3L I/O on-die termination impedance

| Parameter | Typical Impedance | ZQnPR0. ZPROG_HOST_ODT |
|---|-------------------|------------------------|
| Recommended combinations for DQ/CA pins | 120.0 Ω | 1 |
| | 60.0 Ω | 3 |
| | 40.0 Ω | 5 |

NOTE

- Output driver impedance is controlled across PVTs using ZQ calibration procedure.
- Calibration is done against 240 Ω external reference resistor.
- Output driver impedance deviation (calibration accuracy) is $\pm 5\%$ (max/min impedance) across PVTs.

4.8 System Modules Timing

This section contains the timing and electrical parameters for the modules in each processor.

4.8.1 Reset Timing Parameters

The following figure shows the reset timing and [Table 51](#) lists the timing parameters.

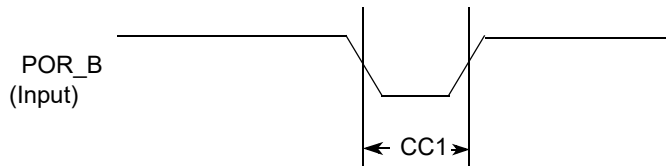

Figure 7. Reset timing diagram

Table 51. Reset timing parameters

| ID | Parameter | Min | Max | Unit |
|-----|--|-----|-----|-------------------------|
| CC1 | Duration of SRC_POR_B to be qualified as valid | 1 | — | XTALOSC_RTC_XTALI cycle |

4.8.2 WDOG reset timing parameters

The following figure shows the WDOG reset timing and Table 52 lists the timing parameters.

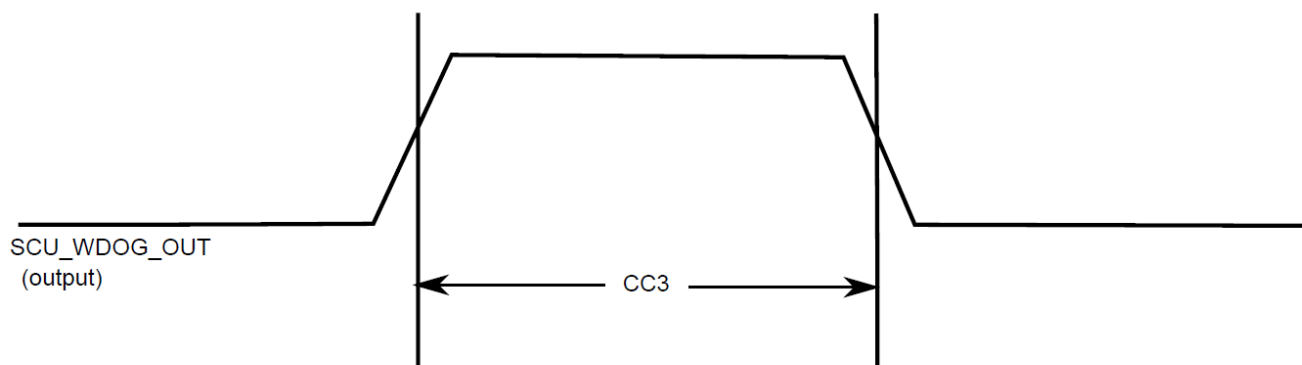

Figure 8. SCU_WDOG_OUT timing diagram

Table 52. WDOG1_B timing parameters

| ID | Parameter | Min | Max | Unit |
|-----|------------------------------------|-----|-----|-------------------------|
| CC3 | Duration of SCU_WDOG_OUT assertion | 1 | — | XTALOSC_RTC_XTALI cycle |

NOTE

XTALOSC_RTC_XTALI is approximately 32 kHz.

XTALOSC_RTC_XTALI cycle is one period or approximately 30 μ s.

4.8.3 DDR SDRAM-specific parameters (LPDDR4 and DDR3L)

The i.MX 8x Family of processors have been designed and tested to work with JEDEC JESD209-4A-compliant LPDDR4 memory and with JEDEC JESD79-3-1 DDR3L compliant with DDR3L memory. Timing diagrams and tolerances required to work with these memories are specified in the respective documents and are not reprinted here.

Meeting the necessary timing requirements for a DDR memory system is highly dependent on the components chosen and the design layout of the system as a whole. NXP cannot cover in this document all the requirements needed to achieve a design that meets full system performance over temperature, voltage, and part variation; PCB trace routing, PCB dielectric material, number of routing layers used, placement of bulk/decoupling capacitors on critical power rails, VIA placement, GND and Supply planes layout, and DDR controller/PHY register settings all are factors affecting the performance of the memory system. Consult the hardware user guide for this device and NXP validated design layouts for information on how to properly design a PCB for best DDR performance. NXP strongly recommends duplicating an NXP validated design as much as possible in the design of critical power rails, placement of bulk/decoupling capacitors and DDR trace routing between the processor and the selected DDR memory. All supporting material is readily available on the device web page on

Electrical characteristics

<https://www.nxp.com/products/processors-and-microcontrollers/applications-processors/i.mx-applications-processors/i.mx-8-processors:IMX8-SERIES> .

Processors that demonstrate full DDR performance on NXP validated designs, but do not function on customer designs, are not considered marginal parts. A report detailing how the returned part behaved on an NXP validated system will be provided to the customer as closure to a customer's reported DDR issue. Customers bear the responsibility of properly designing the Printed Circuit Board, correctly simulating and modeling the designed DDR system, and validating the system under all expected operating conditions (temperatures, voltages) prior to releasing their product to market.

Table 53. i.MX 8 Family DRAM controller supported SDRAM configurations

| Parameter | LPDDR4 |
|-------------------------|---------------------------------|
| Number of Controllers | 2 |
| Number of Channels | 2 per controller |
| Number of Chip Selects | 2 per channel |
| Bus Width | 16 bit per channel ¹ |
| Maximum Clock Frequency | 1600 MHz |

¹ Only 16-bit external memory configurations are supported.

Table 54. i.MX 8QuadXPlus/8DualXPlus DRAM controller supported SDRAM configurations

| Parameter | LPDDR4 | DDR3L |
|-------------------------|--------------------|-----------------------------------|
| Number of Controllers | 1 | |
| Number of Channels | 2 per controller | N/A |
| Number of Chip Selects | 2 per channel | 2 per controller |
| Bus Width | 16-bit per channel | 32-bit (optional 40-bit with ECC) |
| Maximum Clock Frequency | 1200 MHz | 933 MHz |

4.8.3.1 Clock/data/command/address pin allocations

These processors use generic names for clock, data and command address bus (DCF—DRAM controller functions); the following table provides mapping of clock, data and command address signals for LPDDR4 and DDR3L modes.

Table 55. Clock, data, and command address signals for LPDDR4 and DDR3L modes

| Signal name | LPDDR4 |
|-------------|--------|
| DDR_CK0_P | CK_t_A |
| DDR_CK0_N | CK_c_A |

Table 55. Clock, data, and command address signals for LPDDR4 and DDR3L modes (continued)

| Signal name | LPDDR4 |
|-----------------|-------------|
| DDR_CK1_P | CK_t_B |
| DDR_CK1_N | CK_c_B |
| DDR_DQ_[15:0] | DQ[15:0]_A |
| DDR_DQ_[31:16] | DQ[15:0]_B |
| DDR_DQ_[39:32] | |
| DDR_DQS_N_[3:0] | DQS_N_[3:0] |
| DDR_DQS_P_[3:0] | DQS_P_[3:0] |
| DDR_DQS_N_4 | |
| DDR_DQS_P_4 | |
| DDR_DM_[3:0] | DM_[3:0] |
| DDR_DM_4 | |
| DDR_DCF00 | CA2_A |
| DDR_DCF01 | CA4_A |
| DDR_DCF03 | CA5_A |
| DDR_DCF04 | |
| DDR_DCF05 | |
| DDR_DCF07 | |
| DDR_DCF08 | CA3_A |
| DDR_DCF09 | ODT_CA_A |
| DDR_DCF10 | CS0_A |
| DDR_DCF11 | CA0_A |
| DDR_DCF12 | CS1_A |
| DDR_DCF14 | CKE0_A |
| DDR_DCF15 | CKE1_A |
| DDR_DCF16 | CA1_A |
| DDR_DCF17 | CA4_B |
| DDR_DCF18 | RESET_N |
| DDR_DCF19 | CA5_B |
| DDR_DCF20 | |
| DDR_DCF21 | |
| DDR_DCF22 | |
| DDR_DCF23 | |
| DDR_DCF24 | |

Table 55. Clock, data, and command address signals for LPDDR4 and DDR3L modes (continued)

| Signal name | LPDDR4 |
|-------------|----------|
| DDR_DCF25 | ODT_CA_B |
| DDR_DCF26 | CA3_B |
| DDR_DCF27 | CA0_B |
| DDR_DCF28 | CS0_B |
| DDR_DCF29 | CS1_B |
| DDR_DCF30 | CKE0_B |
| DDR_DCF31 | CKE1_B |
| DDR_DCF32 | CA1_B |
| DDR_DCF33 | CA2_B |

4.8.3.2 ECC for DDR3L

i.MX 8QuadXPlus/8DualXPlus supports up to 8-bit ECC when using DDR3L only. This is accomplished through the use of a fifth byte lane (DQS4[P:N],DM4, DQ[32:39]). When using the fifth byte lane, it is not a requirement that all DDR3L devices be identical, but it is required that all devices be able to operate with the same timing parameters. This can be easily accomplished by using memory containing the same die(s), but contained in different packages. Consult the DDR3L device datasheets for timing requirements. The fifth byte lane is for the exclusive use of ECC. If not using ECC, leave the pins as not connected. For LPDDR4 mode, pins DQS4[P:N],DM4, DQ[32:39] are not used and cannot be substituted for one of the other byte lanes. If using LPDDR4 mode, leave these pins as not connected.

4.9 General-Purpose Media Interface (GPMI) Timing

The GPMI controller is a flexible interface NAND Flash controller with 8-bit data width, up to 400 MB/s I/O speed, and individual chip select. It supports Asynchronous Timing mode, Source Synchronous Timing mode, and Toggle Timing mode, as described in the following subsections.

4.9.1 GPMI Asynchronous mode AC timing (ONFI 1.0 compatible)

Asynchronous mode AC timings are provided as multiplications of the clock cycle and fixed delay. The Maximum I/O speed of GPMI in Asynchronous mode is about 50 MB/s. Figure 9 through Figure 12 depict the relative timing between GPMI signals at the module level for different operations under Asynchronous mode. Table 56 describes the timing parameters (NF1–NF17) that are shown in the figures.

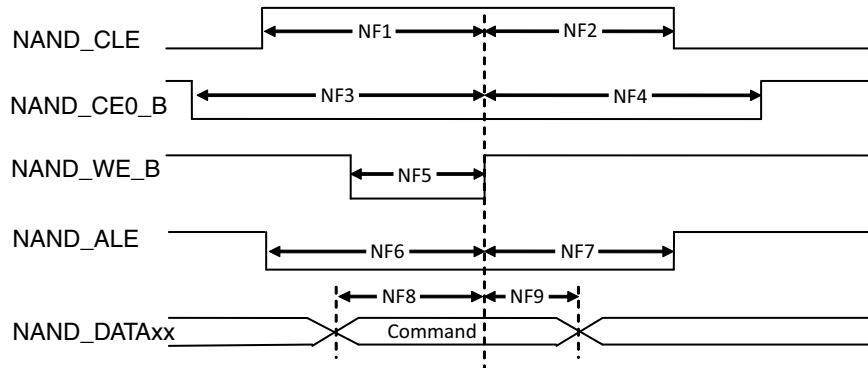

Figure 9. Command Latch Cycle Timing Diagram

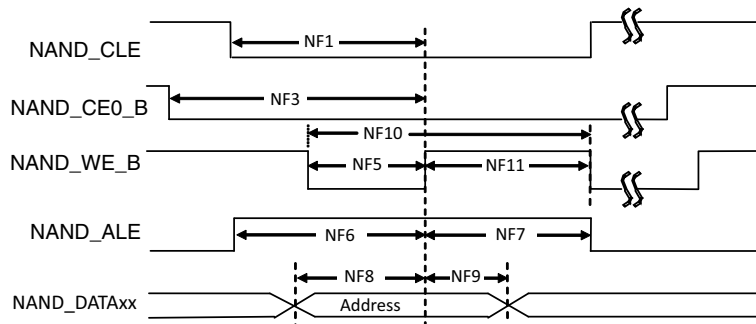

Figure 10. Address Latch Cycle Timing Diagram

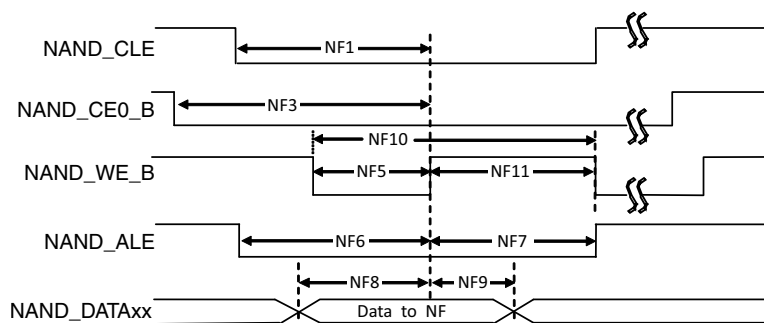

Figure 11. Write Data Latch Cycle Timing Diagram

Electrical characteristics

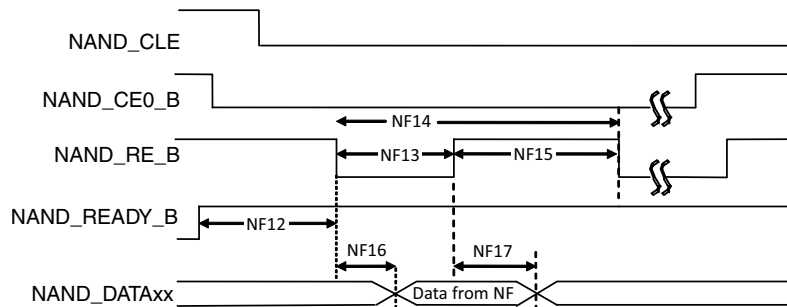

Figure 12. Read Data Latch Cycle Timing Diagram (Non-EDO Mode)

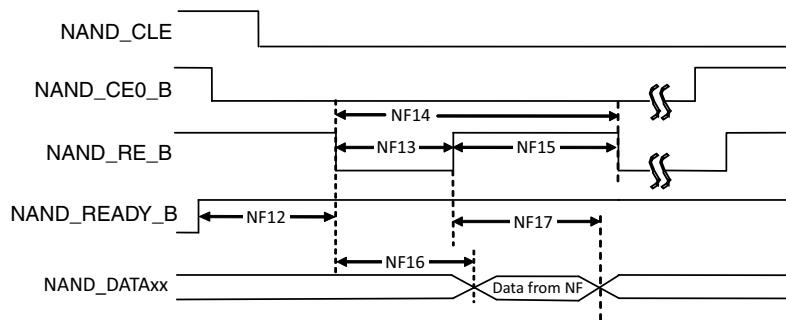

Figure 13. Read Data Latch Cycle Timing Diagram (EDO Mode)

Table 56. Asynchronous Mode Timing Parameters¹

| ID | Parameter | Symbol | Timing T = GPMI Clock Cycle | | Unit |
|------|--------------------------|------------------|---|-----|------|
| | | | Min | Max | |
| NF1 | NAND_CLE setup time | tCLS | $(AS + DS) \times T - 0.12$ [see ^{2,3}] | | ns |
| NF2 | NAND_CLE hold time | tCLH | $DH \times T - 0.72$ [see ²] | | ns |
| NF3 | NAND_CEx_B setup time | tCS | $(AS + DS + 1) \times T$ [see ^{3,2}] | | ns |
| NF4 | NAND_CEx_B hold time | tCH | $(DH+1) \times T - 1$ [see ²] | | ns |
| NF5 | NAND_WE_B pulse width | tWP | $DS \times T$ [see ²] | | ns |
| NF6 | NAND_ALE setup time | tALS | $(AS + DS) \times T - 0.49$ [see ^{3,2}] | | ns |
| NF7 | NAND_ALE hold time | tALH | $(DH \times T - 0.42)$ [see ²] | | ns |
| NF8 | Data setup time | tDS | $DS \times T - 0.26$ [see ²] | | ns |
| NF9 | Data hold time | tDH | $DH \times T - 1.37$ [see ²] | | ns |
| NF10 | Write cycle time | tWC | $(DS + DH) \times T$ [see ²] | | ns |
| NF11 | NAND_WE_B hold time | tWH | $DH \times T$ [see ²] | | ns |
| NF12 | Ready to NAND_RE_B low | tRR ⁴ | $(AS + 2) \times T$ [see ^{3,2}] | — | ns |
| NF13 | NAND_RE_B pulse width | tRP | $DS \times T$ [see ²] | | ns |
| NF14 | READ cycle time | tRC | $(DS + DH) \times T$ [see ²] | | ns |
| NF15 | NAND_RE_B high hold time | tREH | $DH \times T$ [see ²] | | ns |

Table 56. Asynchronous Mode Timing Parameters¹ (continued)

| ID | Parameter | Symbol | Timing T = GPMI Clock Cycle | | Unit |
|------|--------------------|--------|------------------------------------|--|------|
| | | | Min | Max | |
| NF16 | Data setup on read | tDSR | — | $(DS \times T - 0.67)/18.38$ [see ^{5,6}]] | ns |
| NF17 | Data hold on read | tDHR | 0.82/11.83 [see ^{5,6}]] | — | ns |

¹ The GPMI asynchronous mode output timing can be controlled by the module's internal registers HW_GPMI_TIMING0_ADDRESS_SETUP, HW_GPMI_TIMING0_DATA_SETUP, and HW_GPMI_TIMING0_DATA_HOLD. This AC timing depends on these registers settings. In the table, AS/DS/DH represents each of these settings.

² AS minimum value can be 0, while DS/DH minimum value is 1.

³ T = GPMI clock period - 0.075ns (half of maximum p-p jitter).

⁴ NF12 is met automatically by the design.

⁵ Non-EDO mode.

⁶ EDO mode, GPMI clock \approx 100 MHz
(AS=DS=DH=1, GPMI_CTL1 [RDN_DELAY] = 8, GPMI_CTL1 [HALF_PERIOD] = 0).

In EDO mode (Figure 13), NF16/NF17 are different from the definition in non-EDO mode (Figure 12). They are called tREA/tRHOH (NAND_RE_B access time/NAND_RE_B HIGH to output hold). The typical value for them are 16 ns (max for tREA)/15 ns (min for tRHOH) at 50 MB/s EDO mode. In EDO mode, GPMI will sample NAND_DATAxx at rising edge of delayed NAND_RE_B provided by an internal DPLL. The delay value can be controlled by GPMI_CTRL1.RDN_DELAY (see the GPMI chapter of the device reference manual. The typical value of this control register is 0x8 at 50 MT/s EDO mode. However, if the board delay is large enough and cannot be ignored, the delay value should be made larger to compensate the board delay.

4.9.2 GPMI Source Synchronous mode AC timing (ONFI 2.x compatible)

The following figure shows the write and read timing of Source Synchronous mode.

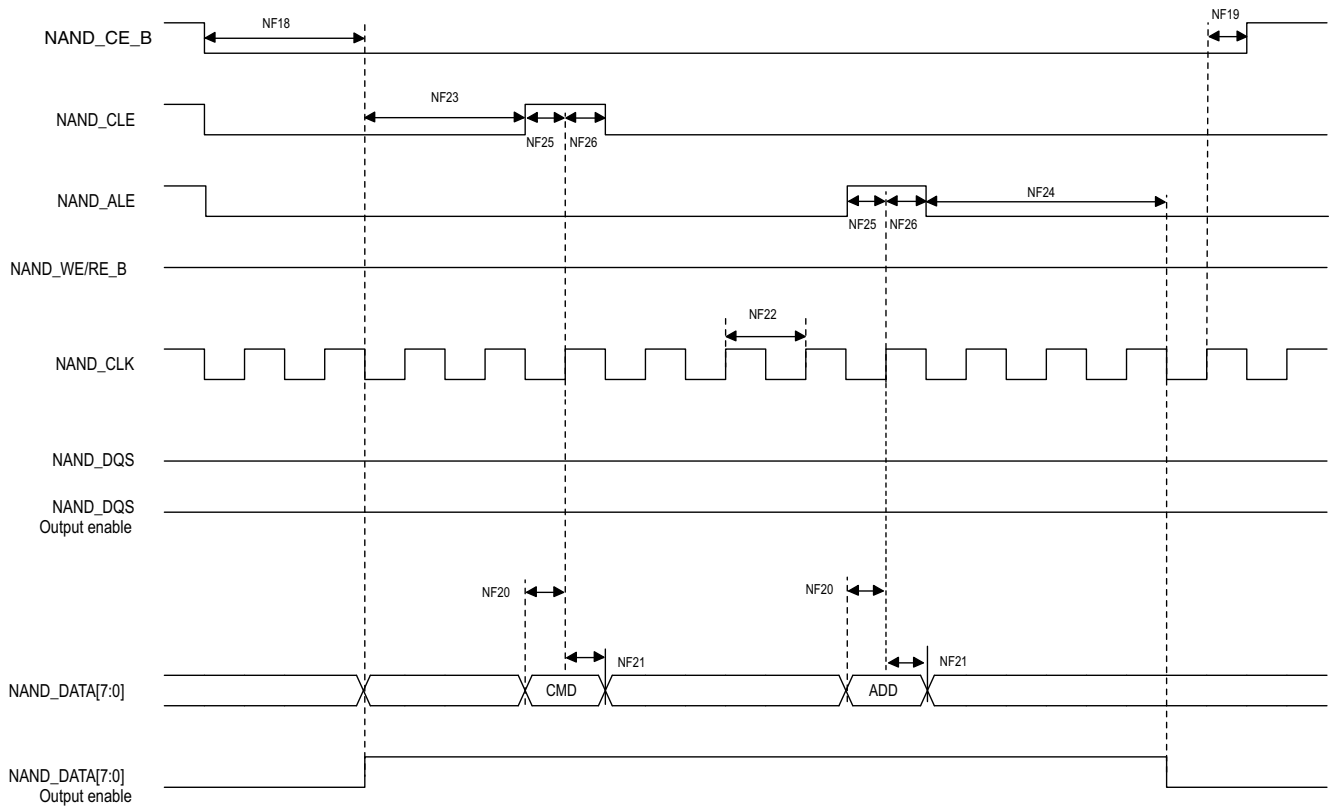

Figure 14. Source Synchronous Mode Command and Address Timing Diagram

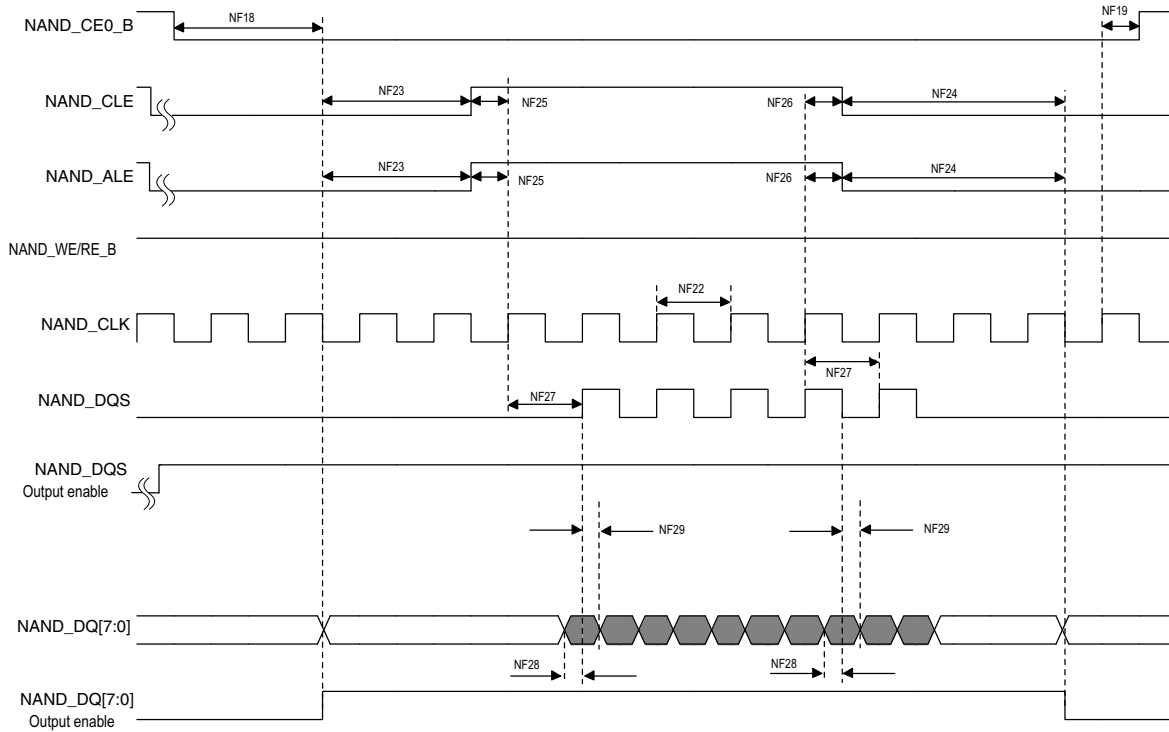

Figure 15. Source Synchronous Mode Data Write Timing Diagram

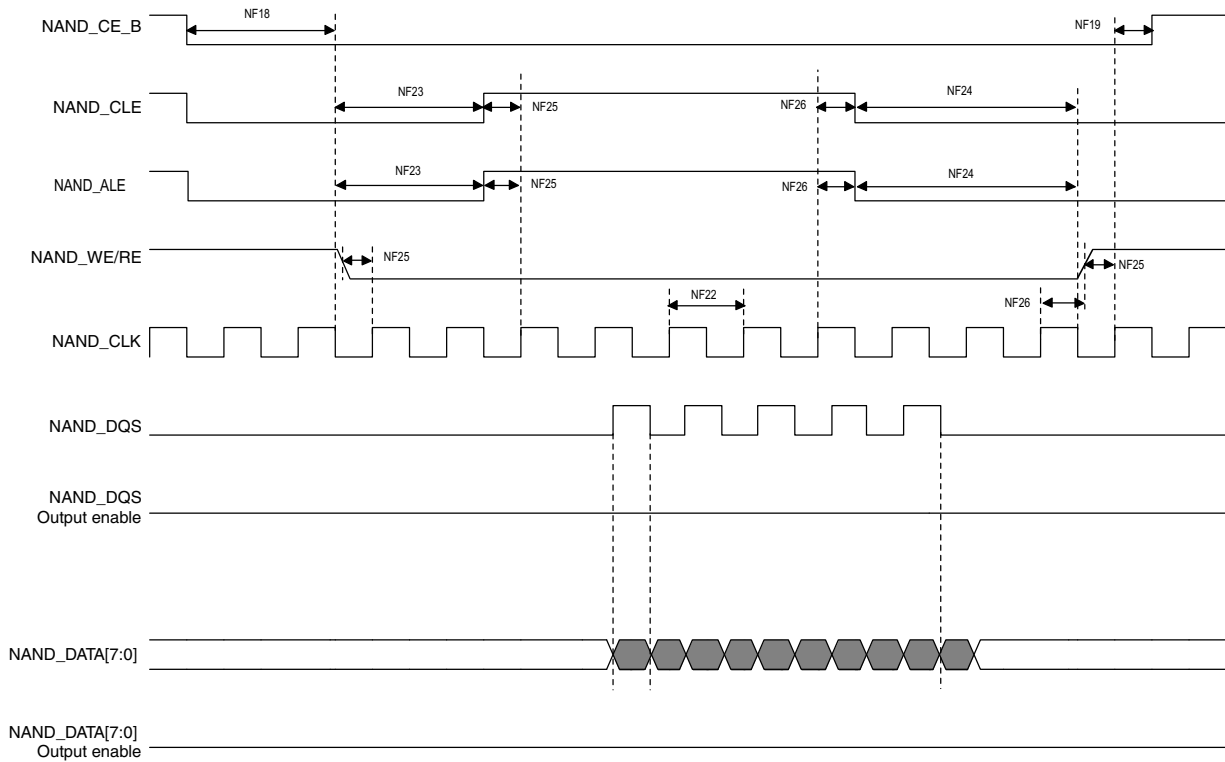

Figure 16. Source Synchronous Mode Data Read Timing Diagram

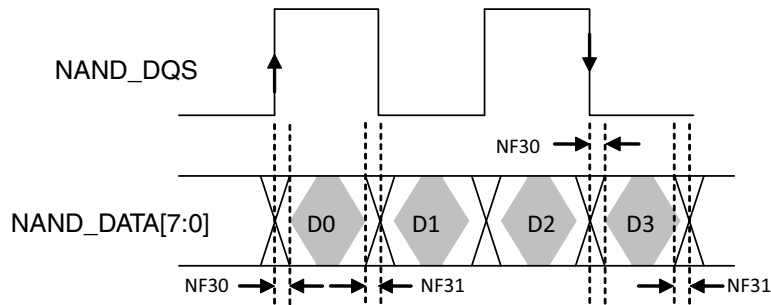

Figure 17. NAND_DQS/NAND_DQ Read Valid Window

Table 57. Source Synchronous Mode Timing Parameters¹

| ID | Parameter | Symbol | Timing T = GPMI Clock Cycle | | Unit |
|------|--|--------|---|------|------|
| | | | Min | Max | |
| NF18 | NAND_CEx_B access time | tCE | $CE_DELAY \times T - 0.79$ [see ²] | | ns |
| NF19 | NAND_CEx_B hold time | tCH | $0.5 \times tCK - 0.63$ [see ²] | | ns |
| NF20 | Command/address NAND_DATAxx setup time | tCAS | $0.5 \times tCK - 0.05$ | | ns |
| NF21 | Command/address NAND_DATAxx hold time | tCAH | $0.5 \times tCK - 1.23$ | | ns |
| NF22 | clock period | tCK | — | | ns |
| NF23 | preamble delay | tPRE | $PRE_DELAY \times T - 0.29$ [see ²] | | ns |
| NF24 | postamble delay | tPOST | $POST_DELAY \times T - 0.78$ [see ²] | | ns |
| NF25 | NAND_CLE and NAND_ALE setup time | tCALs | $0.5 \times tCK - 0.86$ | | ns |
| NF26 | NAND_CLE and NAND_ALE hold time | tCALH | $0.5 \times tCK - 0.37$ | | ns |
| NF27 | NAND_CLK to first NAND_DQS latching transition | tDQSS | $T - 0.41$ [see ²] | | ns |
| NF28 | Data write setup | tDS | $0.25 \times tCK - 0.35$ | | ns |
| NF29 | Data write hold | tDH | $0.25 \times tCK - 0.85$ | | ns |
| NF30 | NAND_DQS/NAND_DQ read setup skew | tDQSQ | — | 2.06 | — |
| NF31 | NAND_DQS/NAND_DQ read hold skew | tQHS | — | 1.95 | — |

¹ The GPMI source synchronous mode output timing can be controlled by the module's internal registers GPMI_TIMING2_CE_DELAY, GPMI_TIMING2_PREAMBLE_DELAY, GPMI_TIMING2_POST_DELAY. This AC timing depends on these registers settings. In the table, CE_DELAY/PRE_DELAY/POST_DELAY represents each of these settings.

² T = tCK (GPMI clock period) - 0.075ns (half of maximum p-p jitter).

Figure 17 shows the timing diagram of NAND_DQS/NAND_DATAxx read valid window. For Source Synchronous mode, the typical value of tDQSQ is 0.85 ns (max) and 1 ns (max) for tQHS at 200 MB/s. GPMI will sample NAND_DATA[7:0] at both rising and falling edge of a delayed NAND_DQS signal, which can be provided by an internal DPLL. The delay value can be controlled by GPMI register GPMI_READ_DDR_DLL_CTRL.SLV_DLY_TARGET (see the GPMI chapter of the device reference manual. Generally, the typical delay value of this register is equal to 0x7 which means 1/4 clock cycle delay expected. However, if the board delay is large enough and cannot be ignored, the delay value should be made larger to compensate the board delay.

4.9.3 ONFI NV-DDR2 mode (ONFI 3.2 compatible)

4.9.3.1 Command and address timing

ONFI 3.2 mode command and address timing is the same as ONFI 1.0 compatible Async mode AC timing. See [Section 4.9.1, “GPMI Asynchronous mode AC timing \(ONFI 1.0 compatible\)”](#), for details.

4.9.3.2 Read and write timing

ONFI 3.2 mode read and write timing is the same as Toggle mode AC timing. See [Section 4.9.4, “Toggle mode AC Timing”](#), for details.

4.9.4 Toggle mode AC Timing

4.9.4.1 Command and address timing

NOTE

Toggle mode command and address timing is the same as ONFI 1.0 compatible Asynchronous mode AC timing. See [Section 4.9.1, “GPMI Asynchronous mode AC timing \(ONFI 1.0 compatible\)”](#), for details.

4.9.4.2 Read and write timing

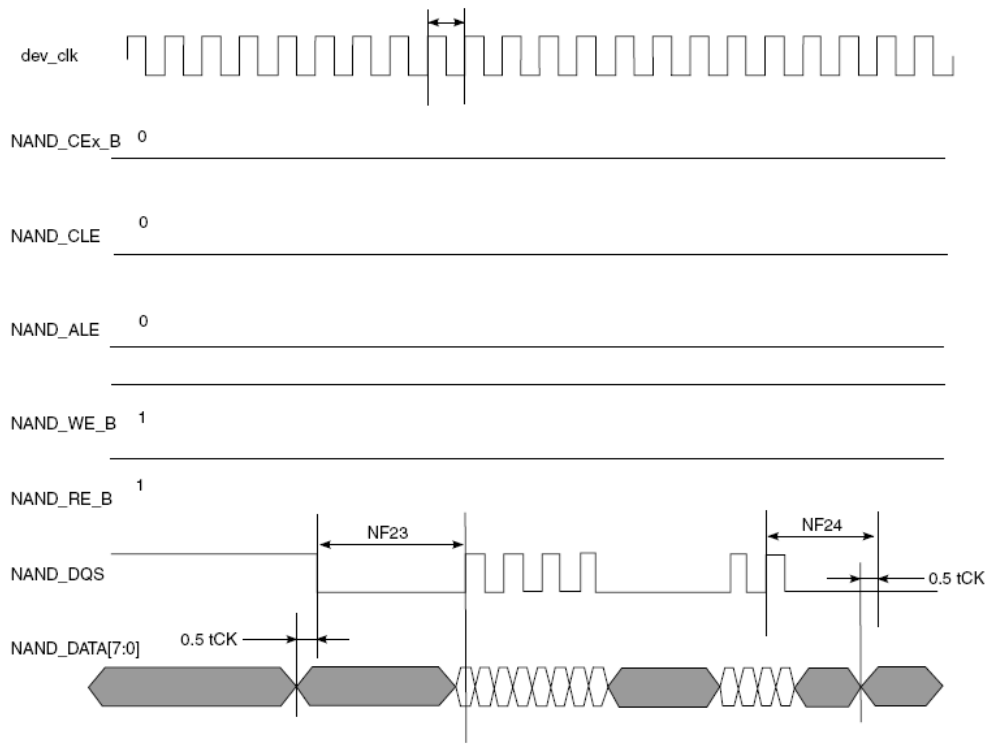

Figure 18. Toggle mode data write timing

Electrical characteristics

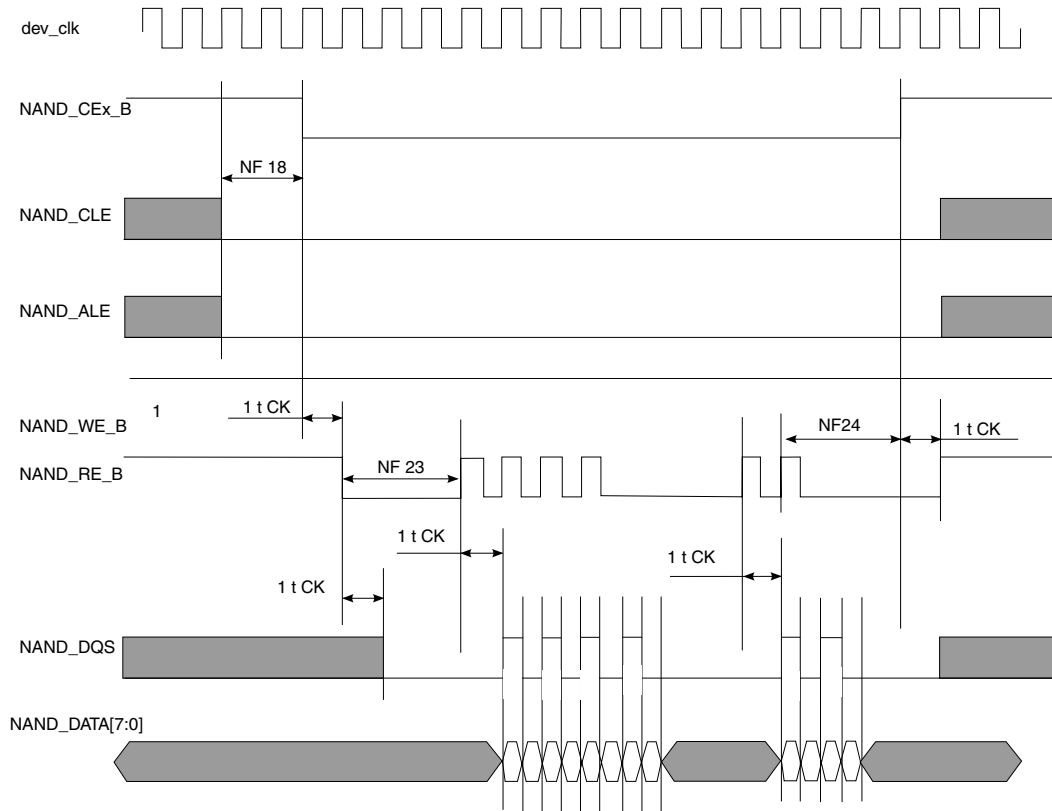

Figure 19. Toggle mode data read timing

Table 58. Toggle mode timing parameters¹

| ID | Parameter | Symbol | Timing T = GPMI Clock Cycle | | Unit |
|------|--|--------|--|------|------|
| | | | Min. | Max. | |
| NF1 | NAND_CLE setup time | tCLS | $(AS + DS) \times T - 0.12$ [see note ^{2,3}] | | |
| NF2 | NAND_CLE hold time | tCLH | $DH \times T - 0.72$ [see note ²] | | |
| NF3 | NAND_CE0_B setup time | tCS | $(AS + DS) \times T - 0.58$ [see notes ²] | | |
| NF4 | NAND_CE0_B hold time | tCH | $DH \times T - 1$ [see note ²] | | |
| NF5 | NAND_WE_B pulse width | tWP | $DS \times T$ [see note ²] | | |
| NF6 | NAND_ALE setup time | tALS | $(AS + DS) \times T - 0.49$ [see notes ²] | | |
| NF7 | NAND_ALE hold time | tALH | $DH \times T - 0.42$ [see note ²] | | |
| NF8 | Command/address NAND_DATAxx setup time | tCAS | $DS \times T - 0.26$ [see note ²] | | |
| NF9 | Command/address NAND_DATAxx hold time | tCAH | $DH \times T - 1.37$ [see note ²] | | |
| NF18 | NAND_CEx_B access time | tCE | $CE_DELAY \times T$ [see notes ^{4,2}] | — | ns |
| NF22 | clock period | tCK | — | — | ns |
| NF23 | preamble delay | tPRE | $PRE_DELAY \times T$ [see notes ^{5,2}] | — | ns |
| NF24 | postamble delay | tPOST | $POST_DELAY \times T + 0.43$ [see note ²] | — | ns |

Table 58. Toggle mode timing parameters¹ (continued)

| ID | Parameter | Symbol | Timing T = GPMI Clock Cycle | | Unit |
|------|----------------------------------|--------------------|--------------------------------|------|------|
| | | | Min. | Max. | |
| NF28 | Data write setup | tDS ⁶ | $0.25 \times tCK - 0.32$ | — | ns |
| NF29 | Data write hold | tDH ⁶ | $0.25 \times tCK - 0.79$ | — | ns |
| NF30 | NAND_DQS/NAND_DQ read setup skew | tDQSQ ⁷ | — | 3.18 | |
| NF31 | NAND_DQS/NAND_DQ read hold skew | tQHS ⁷ | — | 3.27 | |

¹ The GPMI toggle mode output timing can be controlled by the module's internal registers HW_GPMI_TIMING0_ADDRESS_SETUP, HW_GPMI_TIMING0_DATA_SETUP, and HW_GPMI_TIMING0_DATA_HOLD. This AC timing depends on these registers settings. In the table, AS/DS/DH represents each of these settings.

² AS minimum value can be 0, while DS/DH minimum value is 1.

³ T = tCK (GPMI clock period) - 0.075 ns (half of maximum p-p jitter).

⁴ CE_DELAY represents HW_GPMI_TIMING2[CE_DELAY]. NF18 is guaranteed by the design. Read/Write operation is started with enough time of ALE/CLE assertion to low level.

⁵ PRE_DELAY+1) ≥ (AS+DS)

⁶ Shown in Figure 18.

⁷ Shown in Figure 19.

For DDR Toggle mode, Figure 19 shows the timing diagram of NAND_DQS/NAND_DATA_{xx} read valid window. The typical value of tDQSQ is 1.4 ns (max) and 1.4 ns (max) for tQHS at 133 MB/s. GPMI will sample NAND_DATA[7:0] at both rising and falling edge of an delayed NAND_DQS signal, which is provided by an internal DPLL. The delay value of this register can be controlled by GPMI register GPMI_READ_DDR_DLL_CTRL.SLV_DLY_TARGET (see the GPMI chapter of the device reference manual. Generally, the typical delay value is equal to 0x7 which means 1/4 clock cycle delay expected. But if the board delay is big enough and cannot be ignored, the delay value should be made larger to compensate the board delay.

4.10 External Peripheral Interface Parameters

The following subsections provide information on external peripheral interfaces.

4.10.1 LPSPI timing parameters

All LPSPI interfaces do not have the same maximum serial clock frequency. There are two groups. LPSPI interfaces which can operate at 60 MHz in Master mode and 40 MHz in Slave mode and the other group where interfaces operate at 40 MHz in Master mode and 20 MHz in Slave mode. The same performance is achieved at 1.8 V and 3.3 V unless otherwise stated.

Electrical characteristics

Below are the LPSPI interfaces and their respective chip selects:

Table 59. LPSPI interfaces and chip selects

| LPSPI interface | Chip select | Comment |
|--|-------------------------|---|
| 60 MHz in Master mode and 40 MHz in Slave mode | SPI0, SPI2, SPI2b, SPI3 | SPI2 - default SPI2 balls SPI2b - muxed behind audio balls |
| 40 MHz in Master mode and 20 MHz in Slave mode | SPI1, SPI1b, SPI2c | SPI1 - muxed behind SAI balls SPI1b - muxed behind CSI balls SP2c - muxed behind uSDHC1 balls |

4.10.1.1 LPSPI Master mode

Waveform is assuming LPSPI is configured in mode 0, i.e. TCR.CPOL=0b0 and TCR.CPHA=0b0. Timing parameters are valid for all modes using appropriate edge of the clock.

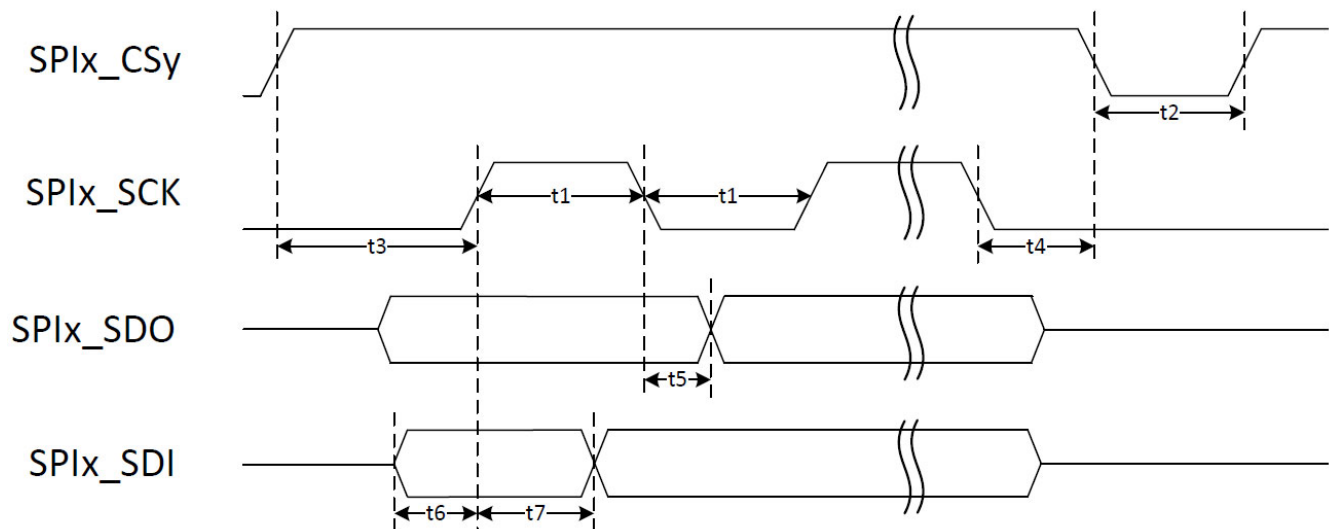

Figure 20. LPSPI Master mode

Table 60. LPSPI timings—Master mode at 60 MHz

| ID | Parameter | Min | Max | Unit |
|----|---|---|-----|------|
| — | SPIx_SCLK Cycle frequency | — | 60 | MHz |
| t1 | SPIx_SCLK High or Low Time—Read SPIx_SCLK High or Low Time—Write | 7.5 | — | ns |
| t2 | SPIx_CSy pulse width | 7.5 | — | ns |
| t3 | SPIx_CSy Lead Time ⁽¹⁾ | $FCLK_PERIOD^{(2)} \times (PCSSCK + 1) / 2^{PRESCALE - 3}$ | — | ns |

Table 60. LPSPI timings—Master mode at 60 MHz (continued)

| ID | Parameter | Min | Max | Unit |
|----|---------------------------------------|---|-----|------|
| t4 | SPIx_CSy Lag Time ⁽³⁾ | $FCLK_PERIOD^{(2)} \times (SCKPCS + 1) / 2^{PRESCALE + 3}$ | — | ns |
| t5 | SPIx_SDO output Delay (CLOAD = 20 pF) | — | 3 | ns |
| t6 | SPIx_SDI Setup Time | 2 | — | ns |
| t7 | SPIx_SDI Hold Time | 2 | — | ns |

¹ This timing is controllable through CCR.PCSSCK and TCR.PRESCALE registers.

² FCLK_PERIOD is the period of the functional clock provided to LPSPI module. Maximum allowed frequency is 240 MHz.

³ This timing is controllable through CCR.SCKPCS and TCR.PRESCALE registers.

Table 61. LPSPI timings—Master mode at 40 MHz

| ID | Parameter | Min | Max | Unit |
|----|---|---|-----|------|
| — | SPIx_SCLK Cycle frequency | — | 40 | MHz |
| t1 | SPIx_SCLK High or Low Time—Read SPIx_SCLK High or Low Time—Write | 11 | — | ns |
| t2 | SPIx_CSy pulse width | 11 | — | ns |
| t3 | SPIx_CSy Lead Time ⁽¹⁾ | $FCLK_PERIOD^{(2)} \times (PCSSCK + 1) / 2^{PRESCALE + 3}$ | — | ns |
| t4 | SPIx_CSy Lag Time ⁽³⁾ | $FCLK_PERIOD^{(2)} \times (SCKPCS + 1) / 2^{PRESCALE + 3}$ | — | ns |
| t5 | SPIx_SDO output Delay (CLOAD = 20 pF) | — | 5 | ns |
| t6 | SPIx_SDI Setup Time | 5 | — | ns |
| t7 | SPIx_SDI Hold Time | 4 | — | ns |

¹ This timing is controllable through CCR.PCSSCK and TCR.PRESCALE registers.

² FCLK_PERIOD is the period of the functional clock provided to LPSPI module. Maximum allowed frequency is 240 MHz.

³ This timing is controllable through CCR.SCKPCS and TCR.PRESCALE registers.

Electrical characteristics

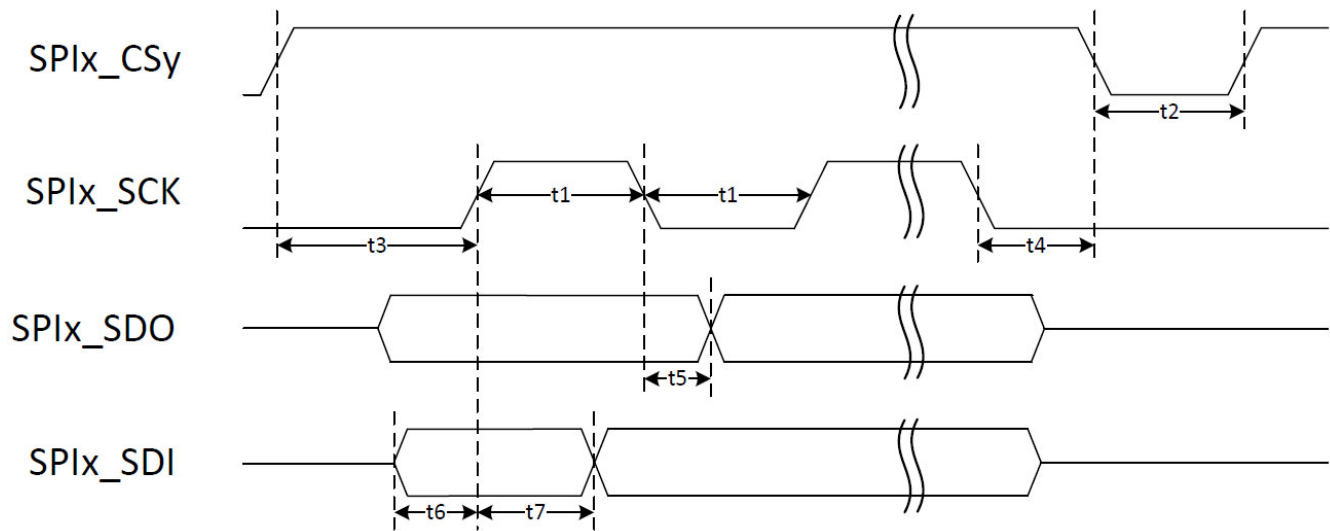

Figure 21. LPSPI Slave mode

Table 62. LPSPI timings—Slave mode at 40 MHz

| ID | Parameter | Min | Max | Unit |
|----|---|-----|-----|------|
| — | SPIx_SCLK Cycle frequency | — | 40 | MHz |
| t1 | SPIx_SCLK High or Low Time—Read SPIx_SCLK High or Low Time—Write | 11 | — | ns |
| t2 | SPIx_CSy pulse width | 11 | — | ns |
| t3 | SPIx_CSy Lead Time (CS setup time) | 4 | — | ns |
| t4 | SPIx_CSy Lag Time (CS hold time) | 2 | — | ns |
| t5 | SPIx_SDO output Delay (CLOAD = 20 pF) | — | 5 | ns |
| t6 | SPIx_SDI Setup Time | 2 | — | ns |
| t7 | SPIx_SDI Hold Time | 2 | — | ns |

Table 63. LPSPI timings—Slave mode at 20 MHz

| ID | Parameter | Min | Max | Unit |
|----|---|-----|-----|------|
| — | SPIx_SCLK Cycle frequency | — | 20 | MHz |
| t1 | SPIx_SCLK High or Low Time—Read SPIx_SCLK High or Low Time—Write | 22 | — | ns |
| t2 | SPIx_CSy pulse width | 22 | — | ns |
| t3 | SPIx_CSy Lead Time (CS setup time) | 4 | — | ns |

Table 63. LPSPi timings—Slave mode at 20 MHz (continued)

| ID | Parameter | Min | Max | Unit |
|----|---------------------------------------|-----|-----|------|
| t4 | SPIx_CSy Lag Time (CS hold time) | 2 | — | ns |
| t5 | SPIx_SDO output Delay (CLOAD = 20 pF) | — | 18 | ns |
| t6 | SPIx_SDI Setup Time | 2 | — | ns |
| t7 | SPIx_SDI Hold Time | 2 | — | ns |

4.10.2 Serial audio interface (SAI) timing parameters

The timings and figures in this section are valid for noninverted clock polarity (I2S_TCR2.BCP = 0b0, I2S_RCR2.BCP = 0b0) and non-inverted frame sync polarity (I2S_TCR4.FSP = 0b0, I2S_RCR4.FSP = 0b0). If the polarity of the clock and/or the frame sync have been inverted, all the timings remain valid by inverting the clock signal (SAI_TXC / SAI_RXC) and/or the frame sync (SAI_TXFS / SAI_RXFS) shown in the figures below.

The same performance is achieved at both 1.8 V and 3.3 V unless otherwise stated.

NOTE

SAI0 and SAI1 are transmit/receive capable. SAI2 and SAI3 are receive only.

4.10.2.1 SAI Master Synchronous mode

In this mode, transmitter clock and frame sync are used by both transmitter and receiver (I2S_TCR2.SYNC=0b00, I2S_RCR2.SYNC=0b01). In that case, SAI interface requires only 4 signals to be routed: SAI_TXC, SAI_TXFS, SAI_TXD and SAI_RXD. SAI_RXC and SAI_RXFS can be left unconnected. I2S_RCR2.BCI shall be set to 0b1 to get setup and hold times provided in Table 64.

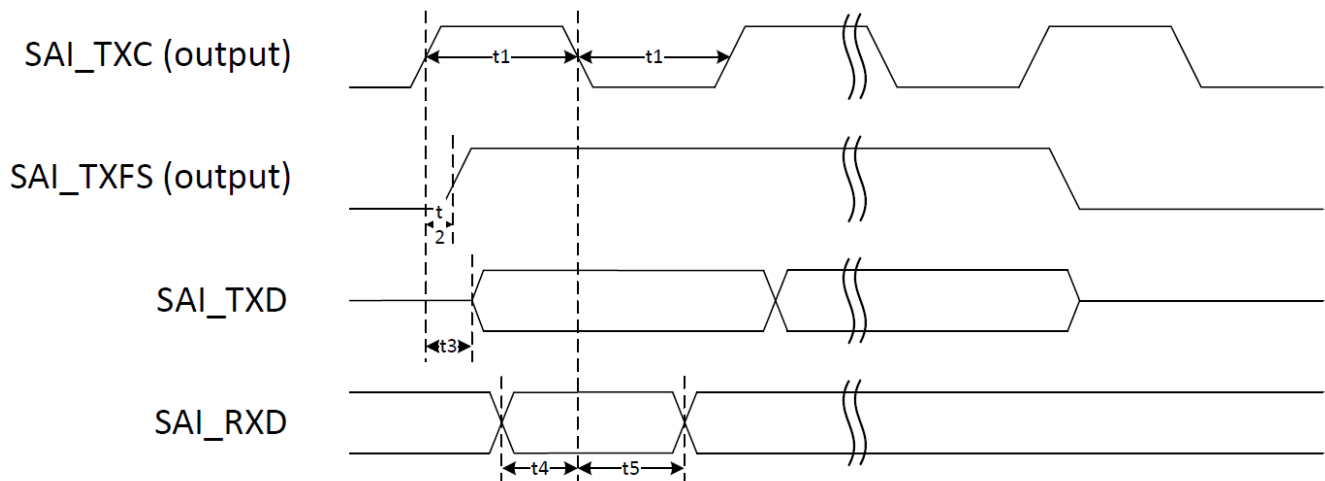

Figure 22. SAI Master Synchronous mode

Table 64. SAI timings—Master Synchronous mode

| ID | Parameters | Min | Max | Unit |
|----|--------------------------------|-----|--------|----------------|
| — | SAI TXC clock frequency | — | 49.152 | MHz |
| t1 | SAI TXC pulse width low / high | 45% | 55% | SAI_TXC period |
| t2 | SAI TXFS output valid | — | 2 | ns |
| t3 | SAI TXD output valid | — | 2 | ns |
| t4 | SAI RXD input setup | 1 | — | ns |
| t5 | SAI RXD input hold | 4 | — | ns |

4.10.2.2 SAI Master mode

In this mode, transmitter and/or receiver part are set to bring out transmit and/or receive clock. Frame sync can be either input or output.

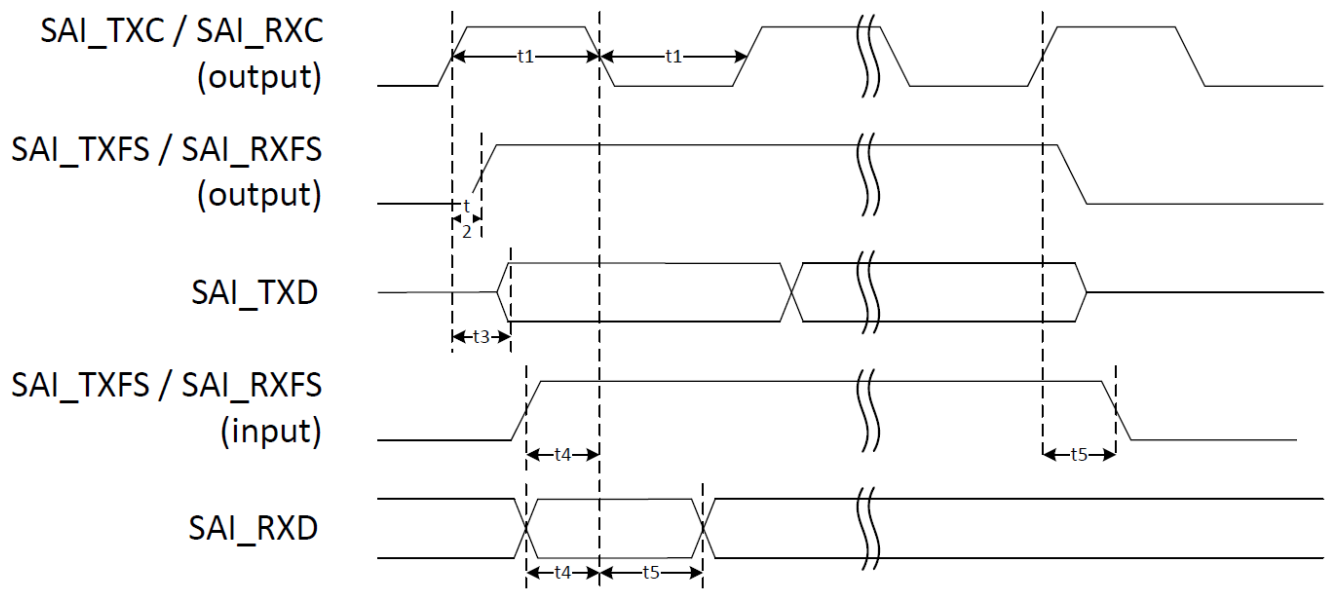

Figure 23. SAI Master mode

Table 65. SAI timings—Master mode

| ID | Parameters | Min | Max | Unit |
|----|--|-----|--------|----------------|
| — | SAI TXC / RXC clock frequency ¹ | — | 49.152 | MHz |
| t1 | SAI TXC / RXC pulse width low / high | 45% | 55% | TXC/RXC period |
| t2 | SAI TXFS / RXFS output valid | — | 2 | ns |

Table 65. SAI timings—Master mode (continued)

| ID | Parameters | Min | Max | Unit |
|----|-------------------------------|-----|-----|------|
| t3 | SAI TXD output valid | — | 2 | ns |
| t4 | SAI RXD/RXFS/TXFS input setup | 6 | — | ns |
| t5 | SAI RXD/RXFS/TXFS input hold | 0 | — | ns |

¹ Given the high setup time requirement on inputs, receiver and transmitter, when using frame sync in input, are likely to run at a lower frequency. This frequency will be driven by characteristics of the external component connected to the interface.

4.10.2.3 SAI Slave mode

In this mode, transmitter and/or receiver parts are set to receive transmit and/or receive clock from external world. Frame sync can be either input or output.

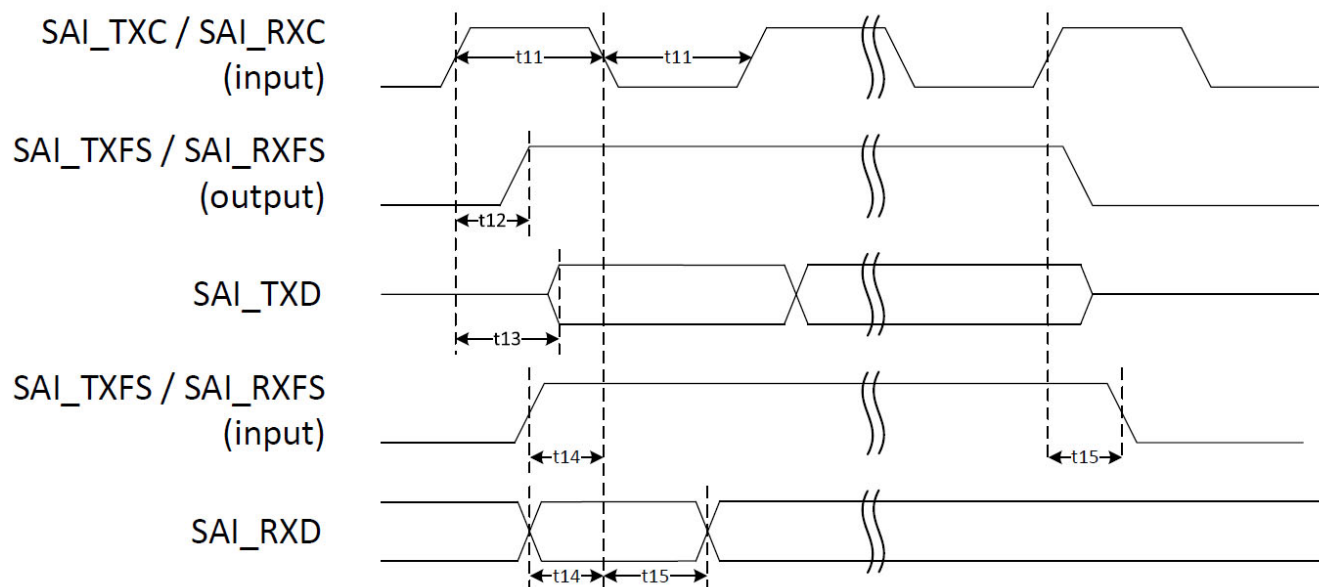

Figure 24. SAI Slave mode

Table 66. SAI timings—Slave mode

| ID | Parameters | Min | Max | Unit |
|-----|----------------------------------|-----|--------|----------------|
| — | SAI TXC/RXC clock frequency | — | 24.576 | MHz |
| t11 | SAI TXC/RXC pulse width low/high | 45% | 55% | TXC/RXC period |
| t12 | SAI TXFS/RXFS output valid | — | 13 | ns |
| t13 | SAI TXD output valid | — | 13 | ns |
| t14 | SAI RXD/RXFS/TXFS input setup | 1 | — | ns |
| t15 | SAI RXD/RXFS/TXFS input hold | 4 | — | ns |

4.10.3 Enhanced serial audio interface (ESAI)

The same performance is achieved at both 1.8 V and 3.3 V unless otherwise stated.

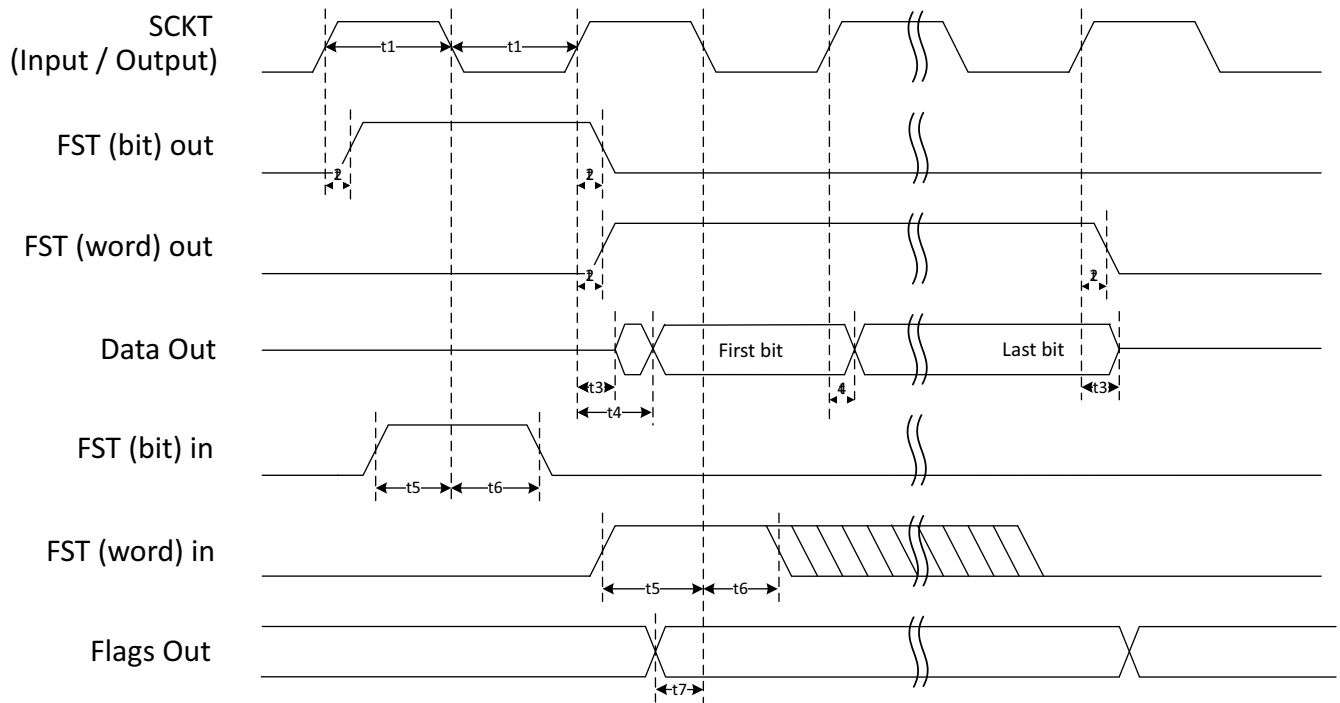

Figure 25. ESAI Transmit timing

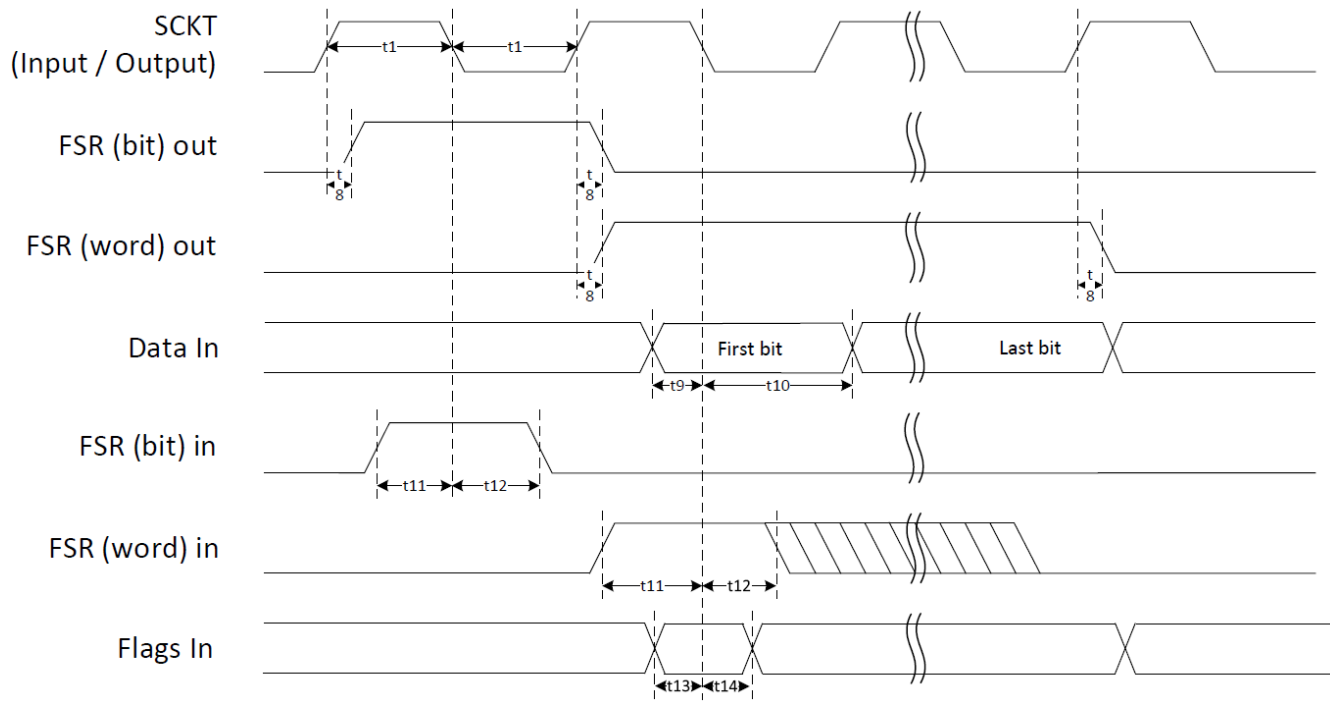

Figure 26. ESAI Receive timing

The following table shows the interface timing values. The ID field in the table refers to timing signals found in [Figure 25](#) and [Figure 26](#).

Table 67. Enhanced Serial Audio Interface (ESAI) Timing

| ID | Parameters | Min | Max | Condition ¹ | Unit |
|----|---------------------------------------|-----|---------|------------------------|--------------------|
| — | Clock frequency | — | 24.576 | — | MHz |
| t1 | SCKT / SCKT pulse width high / low | 45% | 55% | — | SCKT / SCKR period |
| t2 | FST output delay | — | 10 2 | x ck i ck | ns |
| t3 | TX data - high impedance / valid data | — | 9 1 | x ck i ck | ns |
| t4 | TX data output delay | — | 10 2 | x ck i ck | ns |
| t5 | FST - setup requirement | — | 2 10 | x ck i ck | ns |
| t6 | FST - hold requirement | — | 2 0 | x ck i ck | ns |
| t7 | Flag output delay | — | 10 2 | x ck i ck | ns |

Table 67. Enhanced Serial Audio Interface (ESAI) Timing (continued)

| ID | Parameters | Min | Max | Condition ¹ | Unit |
|-----|-----------------------------------|---------|--------|------------------------|------|
| t8 | FSR output delay | | 7 4 | x ck i ck a | ns |
| t9 | RX data pins - setup requirement | 2 10 | — | x ck i ck | ns |
| t10 | RX data pins - hold requirement | 2 0 | — | x ck i ck | ns |
| t11 | FSR - setup requirement | 2 10 | — | x ck i ck a | ns |
| t12 | FSR - hold requirement | 2 0 | — | x ck i ck a | ns |
| t13 | Flags - setup requirement | 2 10 | — | x ck i ck s | ns |
| t14 | Flags - hold requirement | 2 0 | — | x ck i ck s | ns |
| — | RX_HF_CLK / TX_HX_CLK clock cycle | 20 | — | — | ns |
| — | TX_HF_CLK input to SCKT | | 10 | — | ns |
| — | RX_HF_CLK input to SCKR | | 10 | — | ns |

¹ i ck = internal clock
x ck = external clock
i ck a = internal clock, asynchronous mode (SCKT and SCKR are two different clocks)
i ck s = internal clock, synchronous mode (SCKT and SCKR are the same clock)

4.10.4 Ultra High Speed SD/SDIO/MMC Host Interface (uSDHC) AC Timing

This section describes the electrical information of the uSDHC, including:

- [SD3.1/eMMC5.1 High-Speed mode AC Timing](#)
- [eMMC5.1 DDR 52 mode/SD3.1 DDR 50 mode timing](#)
- [HS400 AC timing—eMMC 5.1 only](#)
- [HS200 Mode Timing](#)
- [SDR50/SDR104 AC Timing](#)

4.10.4.1 SD3.1/eMMC5.1 High-Speed mode AC Timing

The following figure depicts the timing of SD3.1/eMMC5.1 High-Speed mode, and Table 68 lists the timing characteristics.

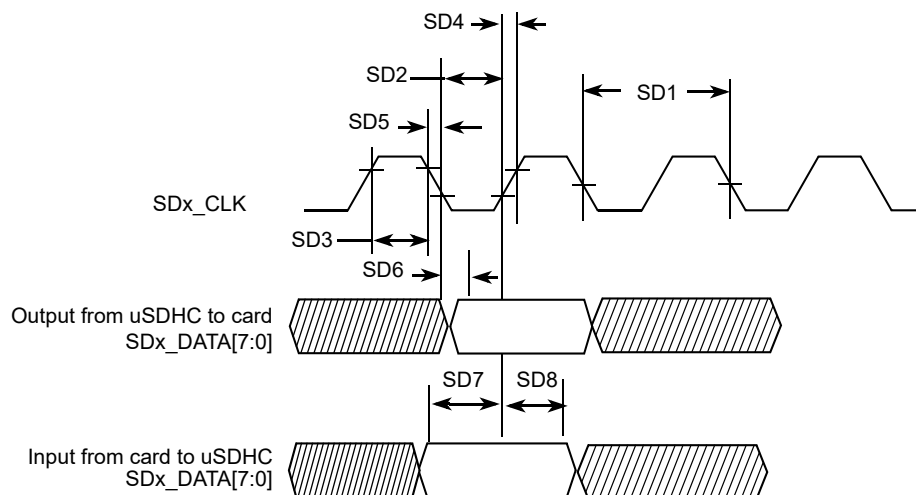

Figure 27. SD3.1/eMMC5.1 High-Speed mode Timing

Table 68. SD3.1/eMMC5.1 High-Speed mode interface timing specification

| ID | Parameter | Symbols | Min | Max | Unit |
|---|---|------------|------|-------|------|
| Card Input Clock | | | | | |
| SD1 | Clock Frequency (Low Speed) | f_{PP}^1 | 0 | 400 | kHz |
| | Clock Frequency (SD/SDIO Full Speed/High Speed) | f_{PP}^2 | 0 | 25/50 | MHz |
| | Clock Frequency (MMC Full Speed/High Speed) | f_{PP}^3 | 0 | 20/52 | MHz |
| | Clock Frequency (Identification Mode) | f_{OD} | 100 | 400 | kHz |
| SD2 | Clock Low Time | t_{WL} | 7 | — | ns |
| SD3 | Clock High Time | t_{WH} | 7 | — | ns |
| SD4 | Clock Rise Time | t_{TLH} | — | 3 | ns |
| SD5 | Clock Fall Time | t_{THL} | — | 3 | ns |
| eSDHC Output/Card Inputs SD_CMD, SD_DATA (Reference to SD_CLK) | | | | | |
| SD6 | eSDHC Output Delay | t_{OD} | -6.6 | 3.6 | ns |
| eSDHC Input/Card Outputs SD_CMD, SD_DATA (Reference to SD_CLK) | | | | | |
| SD7 | eSDHC Input Setup Time | t_{ISU} | 2.5 | — | ns |
| SD8 | eSDHC Input Hold Time ⁴ | t_{IH} | 1.5 | — | ns |

¹ In low speed mode, card clock must be lower than 400 kHz, voltage ranges from 2.7 to 3.6 V.

² In normal (full) speed mode for SD/SDIO card, clock frequency can be any value between 0–25 MHz. In high-speed mode, clock frequency can be any value between 0–50 MHz.

Electrical characteristics

- ³ In normal (full) speed mode for MMC card, clock frequency can be any value between 0–20 MHz. In high-speed mode, clock frequency can be any value between 0–52 MHz.
- ⁴ To satisfy hold timing, the delay difference between clock input and cmd/data input must not exceed 2 ns.

4.10.4.2 eMMC5.1 DDR 52 mode/SD3.1 DDR 50 mode timing

The following figure depicts the timing of eMMC5.1 DDR 52 mode/SD3.1 DDR 50 mode, and Table 69 lists the timing characteristics. Be aware that only SD_x_DATA is sampled on both edges of the clock (not applicable to SD_CMD).

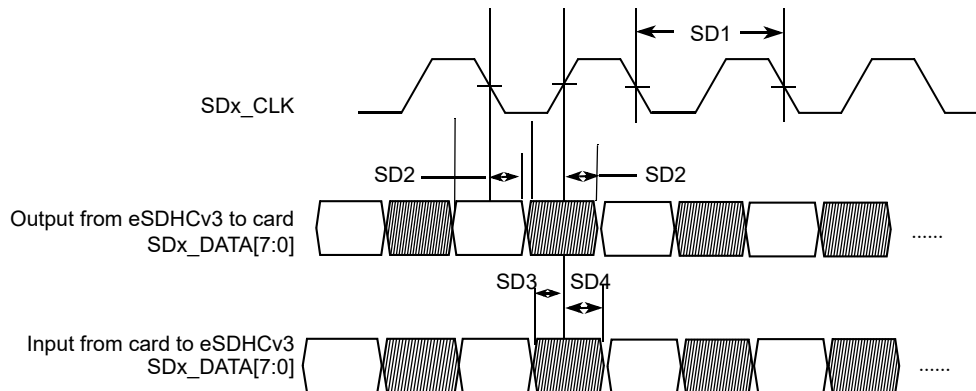

Figure 28. eMMC 5.1 timing

Figure 29. eMMC5.1 DDR 52 mode/SD3.1 DDR 50 mode interface timing

Table 69. eMMC5.1 DDR 52 mode/SD3.150 mode interface timing specification

| ID | Parameter | Symbols | Min | Max | Unit |
|--|-------------------------------|-----------|-----|-----|------|
| Card Input Clock¹ | | | | | |
| SD1 | Clock Frequency (eMMC5.1 DDR) | f_{PP} | 0 | 52 | MHz |
| SD1 | Clock Frequency (SD3.1 DDR) | f_{PP} | 0 | 50 | MHz |
| uSDHC Output / Card Inputs SD_CMD, SD_x_DATA_x (Reference to CLK) | | | | | |
| SD2 | uSDHC Output Delay | t_{OD} | 2.8 | 6.8 | ns |
| uSDHC Input / Card Outputs SD_CMD, SD_x_DATA_x (Reference to CLK) | | | | | |
| SD3 | uSDHC Input Setup Time | t_{ISU} | 1.7 | — | ns |
| SD4 | uSDHC Input Hold Time | t_{IH} | 1.5 | — | ns |

¹ Clock duty cycle will be in the range of 47% to 53%.

4.10.4.3 HS400 AC timing—eMMC 5.1 only

Figure 30 depicts the timing of HS400. Table 70 lists the HS400 timing characteristics. Be aware that only data is sampled on both edges of the clock (not applicable to CMD). The CMD input/output timing for

HS400 mode is the same as CMD input/output timing for SDR104 mode. Check SD5, SD6 and SD7 parameters in Table 72 SDR50/SDR104 Interface Timing Specification for CMD input/output timing for HS400 mode.

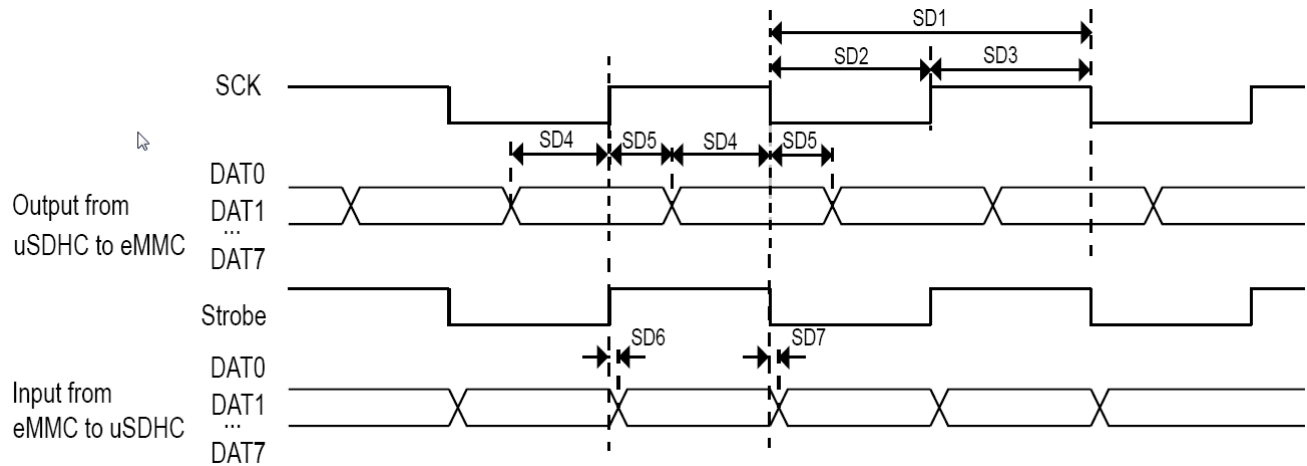

Figure 30. HS400 timing

Table 70. HS400 interface timing specifications

| ID | Parameter | Symbols | Min | Max | Unit |
|---|--------------------------------------|--------------|-----------------------|-----------------------|------|
| Card Input clock | | | | | |
| SD1 | Clock Frequency | f_{PP} | 0 | 200 | Mhz |
| SD2 | Clock Low Time | t_{CL} | $0.46 \times t_{CLK}$ | $0.54 \times t_{CLK}$ | ns |
| SD3 | Clock High Time | t_{CH} | $0.46 \times t_{CLK}$ | $0.54 \times t_{CLK}$ | ns |
| uSDHC Output/Card inputs DAT (Reference to SCK) | | | | | |
| SD4 | Output Skew from Data of Edge of SCK | t_{OSkew1} | 0.45 | — | ns |
| SD5 | Output Skew from Edge of SCK to Data | t_{OSkew2} | 0.45 | — | ns |
| uSDHC input/Card Outputs DAT (Reference to Strobe) | | | | | |
| SD6 | uSDHC input skew | t_{RQ} | — | 0.45 | ns |
| SD7 | uSDHC hold skew | t_{RQH} | — | 0.45 | ns |

4.10.4.4 HS200 Mode Timing

The following figure depicts the timing of HS200 mode, and Table 71 lists the HS200 timing characteristics.

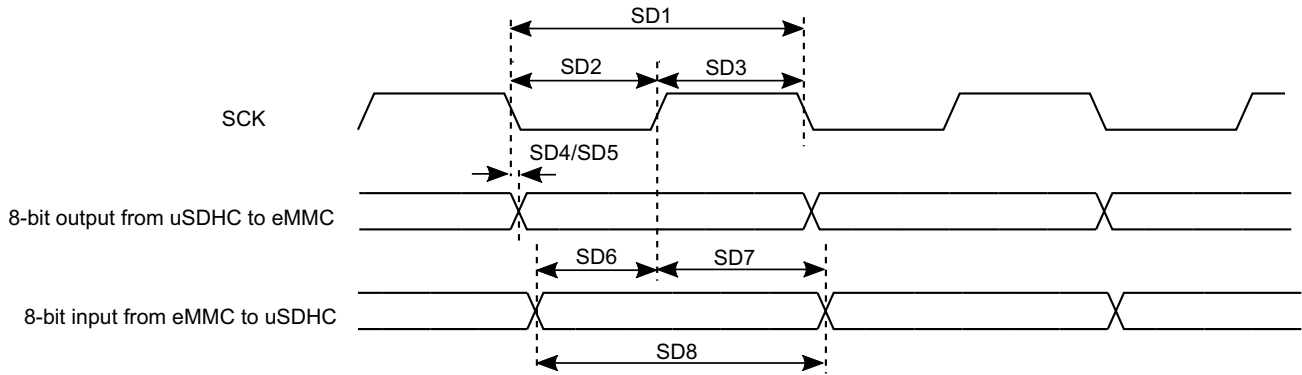

Figure 31. HS200 Mode Timing

Table 71. HS200 Interface Timing Specification

| ID | Parameter | Symbols | Min | Max | Unit |
|---|-------------------------|-----------|-----------------------|-----------------------|------|
| Card Input Clock | | | | | |
| SD1 | Clock Frequency Period | t_{CLK} | 5.0 | — | ns |
| SD2 | Clock Low Time | t_{CL} | $0.46 \times t_{CLK}$ | $0.54 \times t_{CLK}$ | ns |
| SD2 | Clock High Time | t_{CH} | $0.46 \times t_{CLK}$ | $0.54 \times t_{CLK}$ | ns |
| uSDHC Output/Card Inputs SD_CMD, SDx_DATAx in HS200 (Reference to CLK) | | | | | |
| SD5 | uSDHC Output Delay | t_{OD} | -1.6 | 1 | ns |
| uSDHC Input/Card Outputs SD_CMD, SDx_DATAx in HS200 (Reference to CLK)¹ | | | | | |
| SD8 | Card Output Data Window | t_{ODW} | $0.5 \times t_{CLK}$ | — | ns |

¹HS200 is for 8 bits while SDR104 is for 4 bits.

4.10.4.5 SDR50/SDR104 AC Timing

The following figure depicts the timing of SDR50/SDR104, and Table 72 lists the SDR50/SDR104 timing characteristics.

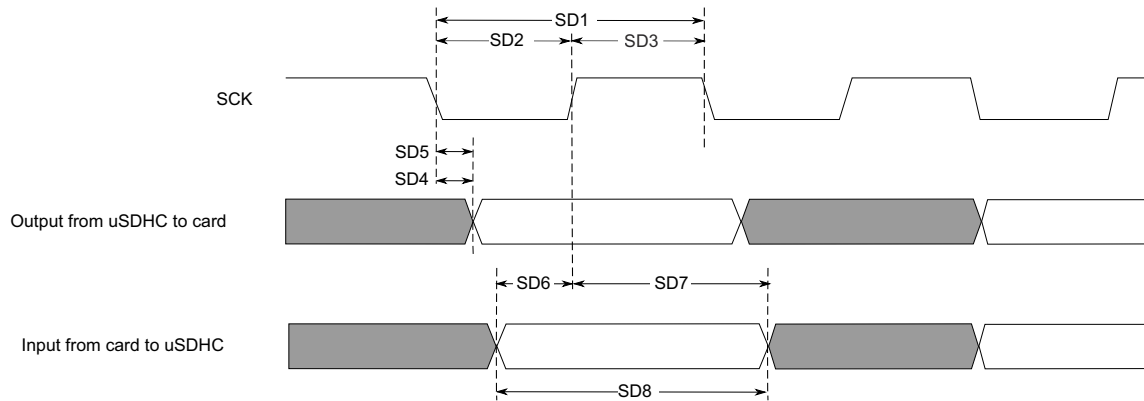

Figure 32. SDR50/SDR104 timing

Table 72. SDR50/SDR104 Interface Timing Specification

| ID | Parameter | Symbols | Min | Max | Unit |
|--|-------------------------|-----------|-----------------------|-----------------------|------|
| Card Input Clock | | | | | |
| SD1 | Clock Frequency Period | t_{CLK} | 4.8 | — | ns |
| SD2 | Clock Low Time | t_{CL} | $0.46 \times t_{CLK}$ | $0.54 \times t_{CLK}$ | ns |
| SD3 | Clock High Time | t_{CH} | $0.46 \times t_{CLK}$ | $0.54 \times t_{CLK}$ | ns |
| uSDHC Output/Card Inputs SD_CMD, SDx_DATAx in SDR50 (Reference to SDx_CLK) | | | | | |
| SD4 | uSDHC Output Delay | t_{OD} | -3 | 1 | ns |
| uSDHC Output/Card Inputs SD_CMD, SDx_DATAx in SDR104 (Reference to SDx_CLK) | | | | | |
| SD5 | uSDHC Output Delay | t_{OD} | -1.6 | 1 | ns |
| uSDHC Input/Card Outputs SD_CMD, SDx_DATAx in SDR50 (Reference to SDx_CLK) | | | | | |
| SD6 | uSDHC Input Setup Time | t_{ISU} | 2.5 | — | ns |
| SD7 | uSDHC Input Hold Time | t_{IH} | 1.5 | — | ns |
| uSDHC Input/Card Outputs SD_CMD, SDx_DATAx in SDR104 (Reference to SDx_CLK)¹ | | | | | |
| SD8 | Card Output Data Window | t_{ODW} | $0.5 \times t_{CLK}$ | — | ns |

¹Data window in SDR100 mode is variable.

4.10.4.6 Bus Operation Condition for 3.3 V and 1.8 V Signaling

Signaling level of SD/eMMC 5.1 and eMMC 5.1 modes is 3.3 V. Signaling level of SDR104/SDR50 mode is 1.8 V. The DC parameters for the NVCC_SD1, NVCC_SD2, and NVCC_SD3 supplies are identical to those shown in “,” and Table 32, "Dual-voltage 1.8 V GPIO DC parameters," on page 39 Table 33, "Dual-voltage 3.3 V GPIO DC parameters," on page 40.

4.10.5 Ethernet Controller (ENET) AC Electrical Specifications

ENET interface supporting RGMII protocol in delay and non-delay mode. RGMII is used to support up to 1000 Mbps Ethernet as well as RMII protocol. RMII is used to support up to 100 Mbps Ethernet.

NOTE

Both ENET0 and ENET1 support RGMII at 1.8 V and 2.5 V, and RMII at 3.3 V.

Table 73. RGMII/RMII pin mapping

| Pin name ¹ | RGMII | RMII | Comment ² |
|-----------------------|---------------|------------|---|
| ENETx_RGMII_TXC | RGMII_TXC | RCLK50M | RCLK50M can be an input or an output. It's using different Alternate pin muxing modes. Refer to pin muxing for details. |
| ENETx_RGMII_TX_CTL | RGMII_TX_CTL | RMII_TXEN | — |
| ENETx_RGMII_TXD0 | RGMII_TXD0 | RMII_TXD0 | — |
| ENETx_RGMII_TXD1 | RGMII_TXD1 | RMII_TXD1 | — |
| ENETx_RGMII_TXD2 | RGMII_TXD2 | N/A | — |
| ENETx_RGMII_TXD3 | RGMII_TXD3 | N/A | — |
| ENETx_RGMII_RXC | RGMII_RXC | N/A | — |
| ENETx_RGMII_RX_CTL | RGMII_RX_CTL | RMII_CRSDV | — |
| ENETx_RGMII_RXD0 | RGMII_RXD0 | RMII_RXD0 | — |
| ENETx_RGMII_RXD1 | RGMII_RXD1 | RMII_RXD1 | — |
| ENETx_RGMII_RXD2 | RGMII_RXD2 | RMII_RXER | RMII_RXER is mapped on ALT1 mode of pin muxing. |
| ENETx_RGMII_RXD3 | RGMII_RXD3 | N/A | — |
| ENETx_REFCLK_125M_25M | RGMII_REF_CLK | N/A | RGMII_REF_CLK is optional for RGMII operation and dependent on the intended clock configuration. |
| ENETx_MDIO | RGMII_MDIO | RMII_MDIO | — |
| ENETx_MDC | RGMII_MDC | RMII_MDC | — |

¹ x can be 0 or 1.

² Except for RCLK50M and RMII_RXER, all other RMII functions are using the same pin muxing mode as RGMII.

4.10.5.1 RGMII

4.10.5.1.1 No-Internal-Delay mode

This mode corresponds to the RGMIIv1.3 specification.

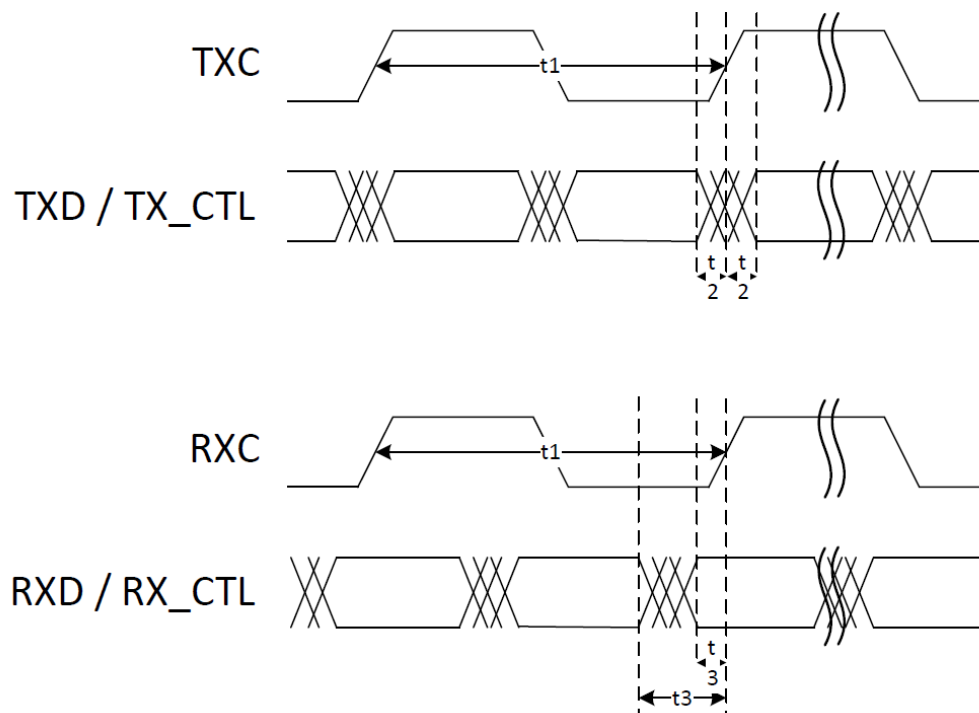

Figure 33. RGMII timing diagram—No-Internal-Delay mode

Table 74. RGMII timings—No-Internal-Delay mode

| ID | Parameter | Min | Typ | Max | Unit |
|----|--|------|-----|-----|------|
| | TXC / RXC frequency | — | 125 | — | MHz |
| t1 | Clock cycle | 7.2 | 8 | 8.8 | ns |
| t2 | Data to clock output skew | -500 | — | 500 | ps |
| t3 | Data to clock input skew ¹⁽¹⁾ | 1 | — | 2.6 | ns |

¹ This implies that PC board design requires clocks to be routed such that an additional trace delay of greater than 1.5 ns and less than 2.0 ns is added to the associated clock signal.

4.10.5.1.2 Internal-delay mode

This mode corresponds to RGMIIv2.0 specification.

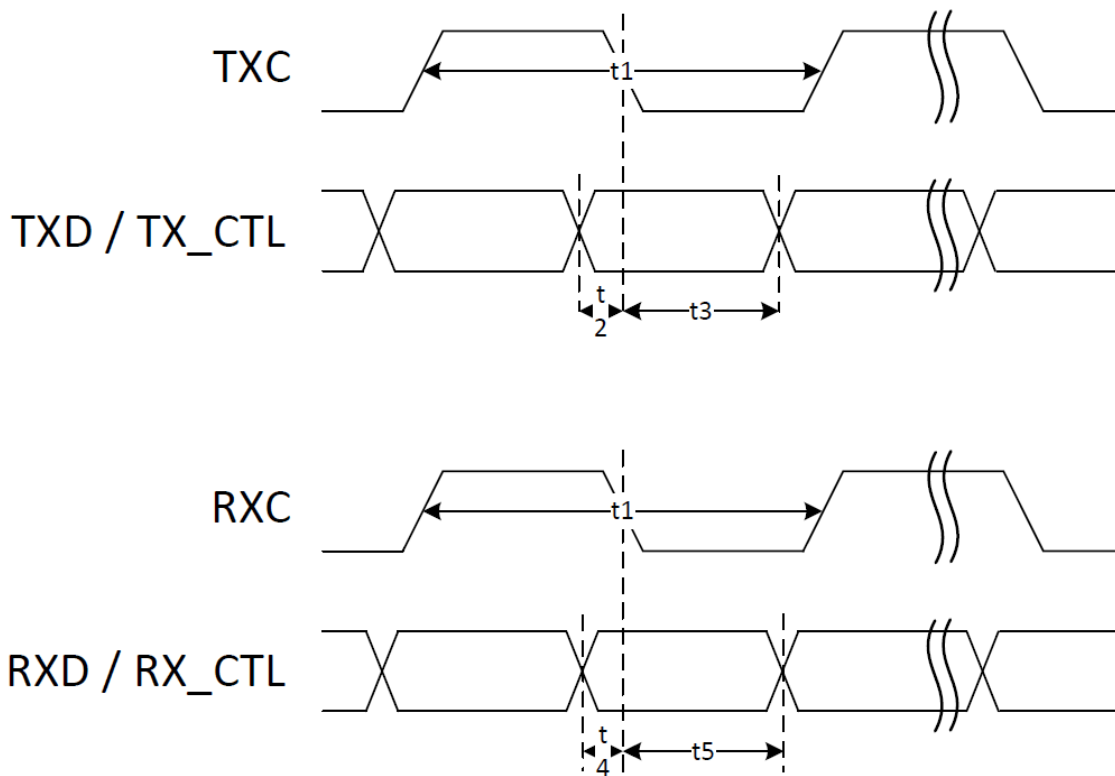

Figure 34. RGMII timing diagram—Internal-Delay mode

Table 75. RGMII timing—Internal-Delay mode

| ID | Parameter | Min | Typ | Max | Unit |
|----|---------------------|-----|-----|-----|------|
| | TXC / RXC frequency | — | 125 | — | MHz |
| t1 | Clock cycle | 7.2 | 8 | 8.8 | ns |
| t2 | TXD setup time | 1.2 | — | — | ns |
| t3 | TXD hold time | 1.2 | — | — | ns |
| t4 | RXD setup time | 0 | — | — | ns |
| t5 | RXD hold time | 2.5 | — | — | ns |

4.10.5.2 RMII

RMII interface is matching RMII v1.2 specification. In RMII mode, the reference clock can be generated internally and provided to the PHY through RCLK50M_OUT. Or, it come from an external 50MHz clock generator which is connected to the PHY and to i.MX8 through RCLK50M_IN pin.

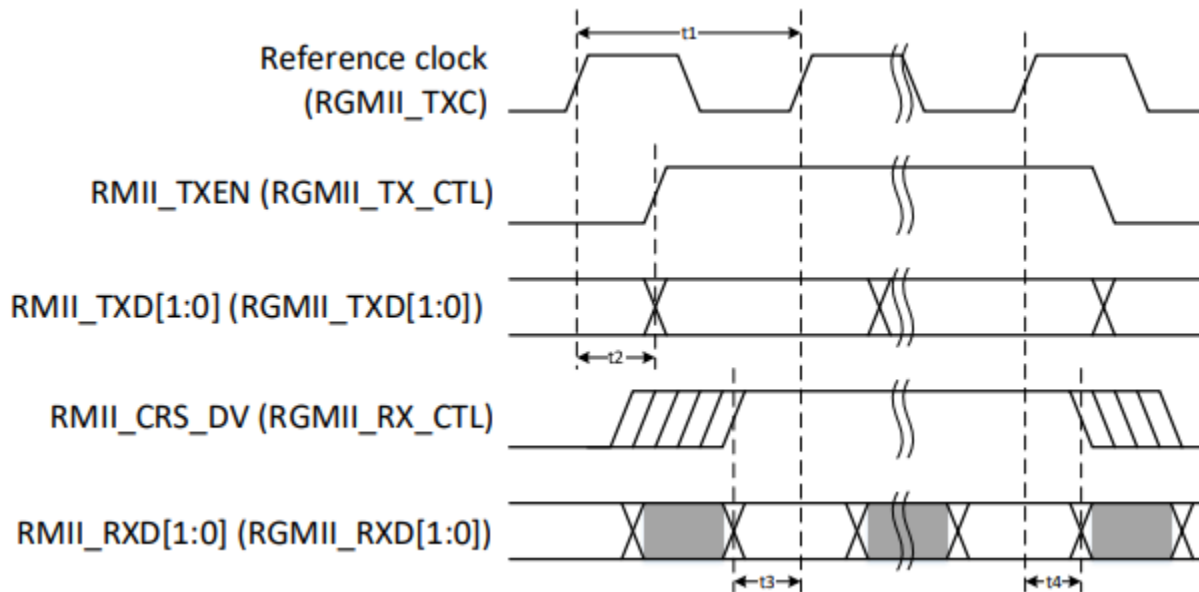

Figure 35. RMII timing diagram

Timings in table below are covering both cases: reference clock generated internally or externally.

Table 76. RMII timing

| ID | Parameter | Min | Typ | Max | Unit |
|----|----------------------------------|-----|-----|-----|------|
| t1 | Reference clock | — | 50 | — | MHz |
| | Reference clock accuracy | — | — | 50 | ppm |
| | Reference clock duty-cycle | 35 | — | 65 | % |
| t2 | RMII_TXEN, RMII_TXD output delay | 2 | — | 12 | ns |
| t3 | RMII_CRS_DV, RMII_RXD setup time | 4 | — | — | ns |
| t4 | RMII_CRS_DV, RMII_RXD hold time | 2 | — | — | ns |

4.10.5.3 MDIO

MDIO is the control link used to configure Ethernet PHY connected to i.MX8 device.

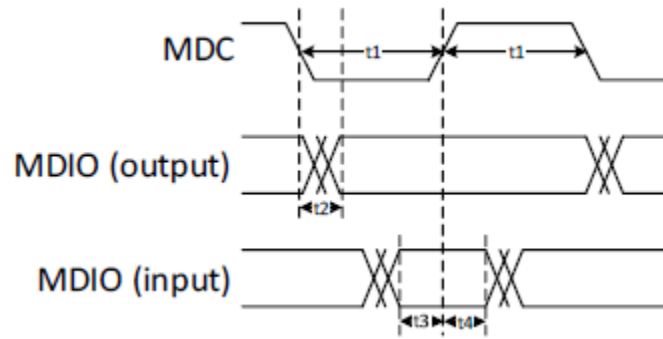

Figure 36. MDIO timing diagram

Table 77. MDIO timing

| ID | Parameter | Min | Typ | Max | Unit |
|----|----------------------------|-----|-----|-----|------|
| | MDC frequency | — | 2.5 | — | MHz |
| t1 | MDC high / low pulse width | 180 | — | — | % |
| t2 | MDIO output delay | 0 | — | 20 | ns |
| t3 | MDIO setup time | 10 | — | — | ns |
| t4 | MDIO hold time | 10 | — | — | ns |

4.10.6 CAN network AC Electrical Specifications

The Flexible Controller Area Network (FlexCAN) module is a communication controller implementing the CAN protocol according to the CAN with Flexible Data rate (CAN FD) protocol and the CAN 2.0B protocol specification. The processor has three CAN modules available for systems design. Tx and Rx ports for both modules are multiplexed with other I/O pins. See the IOMUXC chapter of the device reference manual to see which pins expose Tx and Rx pins; these ports are named FLEXCAN_TX and FLEXCAN_RX, respectively.

4.10.7 I²C Module Timing Parameters

This section describes the timing parameters of the I²C module. The following figure depicts the timing of the I²C module, and [Table 78](#) lists the I²C module timing characteristics.

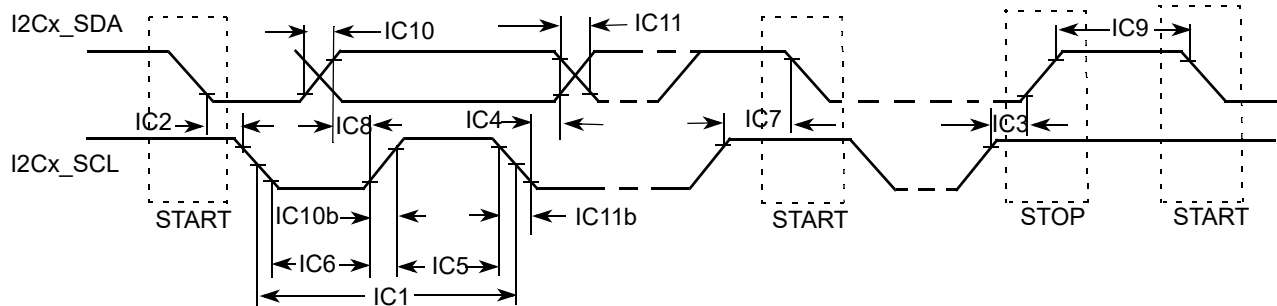

Figure 37. I²C bus timing

Table 78. I²C Module Timing Parameters

| ID | Parameter | Standard Mode | | Fast Mode | | Unit |
|------------|---|----------------|-------------------|-------------------------------------|------------------|------|
| | | Min | Max | Min | Max | |
| IC1 | I2Cx_SCL cycle time | 10 | — | 2.5 | — | μs |
| IC2 | Hold time (repeated) START condition | 4.0 | — | 0.6 | — | μs |
| IC3 | Set-up time for STOP condition | 4.0 | — | 0.6 | — | μs |
| IC4 | Data hold time | 0 ¹ | 3.45 ² | 0 ¹ | 0.9 ² | μs |
| IC5 | HIGH Period of I2Cx_SCL Clock | 4.0 | — | 0.6 | — | μs |
| IC6 | LOW Period of the I2Cx_SCL Clock | 4.7 | — | 1.3 | — | μs |
| IC7 | Set-up time for a repeated START condition | 4.7 | — | 0.6 | — | μs |
| IC8 | Data set-up time | 250 | — | 100 ³ | — | ns |
| IC9 | Bus free time between a STOP and START condition | 4.7 | — | 1.3 | — | μs |
| IC10/IC10b | Rise time of both I2Cx_SDA and I2Cx_SCL signals | — | 1000 | 20 + 0.1C _b ⁴ | 300 | ns |
| IC11/IC11b | Fall time of both I2Cx_SDA and I2Cx_SCL signals | — | 300 | 20 + 0.1C _b ⁴ | 300 | ns |
| IC12 | Capacitive load for each bus line (C _b) | — | 400 | — | 400 | pF |

¹ A device must internally provide a hold time of at least 300 ns for I2Cx_SDA signal in order to bridge the undefined region of the falling edge of I2Cx_SCL.

² The maximum hold time has only to be met if the device does not stretch the LOW period (ID no IC5) of the I2Cx_SCL signal.

³ A Fast-mode I2C-bus device can be used in a Standard-mode I2C-bus system, but the requirement of Set-up time (ID No IC7) of 250 ns must be met. This automatically is the case if the device does not stretch the LOW period of the I2Cx_SCL signal. If such a device does stretch the LOW period of the I2Cx_SCL signal, it must output the next data bit to the I2Cx_SDA line $\text{max_rise_time (IC9) + data_setup_time (IC7) = 1000 + 250 = 1250 ns}$ (according to the Standard-mode I2C-bus specification) before the I2Cx_SCL line is released.

⁴ C_b = total capacitance of one bus line in pF.

Table 79. I2C timing

| ID | Parameter | Fast Mode Plus | | High Speed ¹ | | Unit |
|-------|--|-----------------------------|-----|-------------------------|-----|------|
| | | Min | Max | Min | Max | |
| IC1 | SCL clock frequency | — | 1 | — | 3.4 | MHz |
| IC2 | Hold time (repeated) START condition | 260 | — | 160 | — | ns |
| IC3 | Set-up time for STOP condition | 260 | — | 160 | — | ns |
| IC4 | Data hold time | 0 | — | 0 | 70 | ns |
| IC5 | HIGH Period of I2Cx_SCL Clock | 260 | — | 60 | — | ns |
| IC6 | LOW Period of the I2Cx_SCL Clock | 500 | — | 160 | — | ns |
| IC7 | Set-up time for a repeated START condition | 260 | — | 160 | — | ns |
| IC8 | Data set-up time | 50 | — | 10 | — | ns |
| IC9 | Bus free time between a STOP and START condition | 500 | — | 150 | — | ns |
| IC10 | Rise time of I2Cx_SDA signals | — | 120 | 10 | 80 | ns |
| IC11 | Fall time of I2Cx_SDA signals | 12 (@3.3 V) 6.5 (@1.8 V) | 120 | 10 | 80 | ns |
| IC10b | Rise time of I2Cx_SCL signals | — | 120 | 10 | 40 | ns |
| IC11b | Fall time of I2Cx_SCL signals | 12 (@3.3 V) 6.5 (@1.8 V) | 120 | 10 | 40 | ns |
| IC12 | Capacitive load for each bus line (Cb) | — | 550 | — | 100 | pF |

¹ High-speed mode is only available for I2C modules in DMA, SCU and Cortex-M4 subsystems.

4.10.8 MIPI-DSI/LVDS combo display output specifications

The physical pins of the combo display output controller can be used in LVDS mode or in DSI display mode.

4.10.8.1 MIPI-DSI/LVDS display bridge module parameters

Maximum frequency support for combination MIPI-DSI/LVDS modules:

Table 80. MIPI-DSI/LVDS combo pins

| Function ^{1,2} | Channel A | Channel B |
|-------------------------|-------------------------------------|-------------------------------------|
| DSI | DSI up to 1.05 Gb/per lane | DSI up to 1.05 Gb/per lane |
| Mix | 4 pairs LVDS up to 1.05 Gb per pair | DSI up to 1.05 Gb/per lane |
| Mix | DSI up to 1.05 Gb/per lane | 4 pairs LVDS up to 1.05 Gb per pair |

Table 80. MIPI-DSI/LVDS combo pins (continued)

| Function ^{1,2} | Channel A | Channel B |
|-------------------------|-------------------------------------|-------------------------------------|
| LVDS (single channel) | 4 pairs LVDS up to 1.05 Gb per pair | 4 pairs LVDS up to 1.05 Gb per pair |
| LVDS (dual channel) | 8 pairs LVDS up to 595 Mb per pair | |

¹ For DSI the maximum clock speed is 1.05 GHz.

² For LVDS in single-channel operation the maximum clock speed is 150 MHz; in dual-channel operation with a single synchronized clock the maximum clock speed is 85 MHz.

4.10.8.2 LVDS display bridge (LDB) module electrical specifications

The MIPI DSI/LVDS interface is compatible with TIA/EIA 644-A standard. For more details, see TIA/EIA STANDARD 644-A, “Electrical Characteristics of Low Voltage Differential Signaling (LVDS) Interface Circuits.”

Table 81. LVDS Display Bridge (LDB) Electrical Specifications

| Parameter | Symbol | Test Condition | Min | Max | Units |
|-------------------------------------|--------------|--|-------|-------|-------|
| Differential Voltage Output Voltage | V_{OD} | 100 Ω Differential load | 0.25 | 0.4 | V |
| Output Voltage High | V_{OH} | 100 Ω differential load (0 V Diff—Output High Voltage static) | — | 1.475 | V |
| Output Voltage Low | V_{OL} | 100 Ω differential load (0 V Diff—Output Low Voltage static) | 0.925 | — | V |
| Offset Static Voltage | V_{OS} | Two 49.9 Ω resistors in series between N-P terminal, with output in either Zero or One state, the voltage measured between the 2 resistors. | 1.125 | 1.275 | V |
| VOS Differential | V_{OSDIFF} | Difference in V_{OS} between a One and a Zero state | — | — | mV |
| Output short-circuited to GND | ISA ISB | With the output common shorted to GND | — | 40 | mA |
| Output short current | ISAB | | — | 12 | mA |

4.10.8.3 MIPI-DSI HS-TX specifications

Table 82. MIPI high-speed transmitter DC specifications

| Symbol | Parameter | Min | Typ | Max | Unit |
|-----------------------------|---|-----|-----|-----|------|
| V_{CMTX}^1 | High Speed Transmit Static Common Mode Voltage | 150 | 200 | 250 | mV |
| $ \Delta V_{CMTX} _{(1,0)}$ | V_{CMTX} mismatch when Output is Differential-1 or Differential-0 | — | — | 5 | mV |
| $ V_{OD} ^1$ | High Speed Transmit Differential Voltage | 140 | 200 | 270 | mV |

Electrical characteristics

Table 82. MIPI high-speed transmitter DC specifications (continued)

| Symbol | Parameter | Min | Typ | Max | Unit |
|-------------------|---|-----|-----|------|----------|
| $ \Delta V_{OD} $ | V_{OD} mismatch when Output is Differential-1 or Differential-0 | — | — | 10 | mV |
| V_{OHHS}^1 | High Speed Output High Voltage | — | — | 360 | mV |
| Z_{OS} | Single Ended Output Impedance | 40 | 50 | 62.5 | Ω |
| ΔZ_{OS} | Single Ended Output Impedance Mismatch | — | — | 10 | % |

¹ Value when driving into load impedance anywhere in the Z_{ID} range.

Table 83. MIPI high-speed transmitter AC specifications

| Symbol | Parameter | Min | Typ | Max | Unit |
|-----------------------|---|-----|-----|---------|--------|
| $\Delta V_{CMTX(HF)}$ | Common-level variations above 450 MHz | — | — | 15 | mVRMS |
| $\Delta V_{CMTX(LF)}$ | Common-level variation between 50-450 MHz | — | — | 25 | mVPEAK |
| t_R and t_F^1 | Rise Time and Fall Time (20% to 80%) | 100 | — | 0.35 UI | ps |

¹ UI is the long-term average unit interval.

4.10.8.4 MIPI-DSI LP-TX specifications

Table 84. MIPI low-power transmitter DC specifications

| Symbol | Parameter | Min | Typ | Max | Unit |
|-------------|---|-----|-----|-----|----------|
| V_{OH}^1 | Thevenin Output High Level | 1.1 | 1.2 | 1.3 | V |
| V_{OL} | Thevenin Output Low Level | -50 | — | 50 | mV |
| Z_{OLP}^2 | Output Impedance of Low Power Transmitter | 110 | — | — | Ω |

¹ This specification can only be met when limiting the core supply variation from 1.1 V till 1.3 V.

² Although there is no specified maximum for Z_{OLP} , the LP transmitter output impedance ensures the $TRLP/TFLP$ specification is met.

Table 85. MIPI low-power transmitter AC specifications

| Symbol | Parameter | Min | Typ | Max | Unit |
|---------------------|--|-----|-----|-----|------|
| T_{RLP}/T_{FLP}^1 | 15% to 85% Rise Time and Fall Time | — | — | 25 | ns |
| $T_{REOT}^{1,2,3}$ | 30% to 85% Rise Time and Fall Time | — | — | 35 | ns |
| $T_{LP-PULSE-TX}^4$ | Pulse width of the LP exclusive-OR clock: First LP exclusive-OR clock pulse after Stop state or last pulse before Stop state | 40 | — | — | ns |
| | Pulse width of the LP exclusive-OR clock: All other pulses | 20 | — | — | ns |
| $T_{LP-PER-TX}$ | Period of the LP exclusive-OR clock | 90 | — | — | ns |

Table 85. MIPI low-power transmitter AC specifications (continued)

| Symbol | Parameter | Min | Typ | Max | Unit |
|---|---------------------------------------|-----|-----|-----|-------|
| $\delta V/\delta t_{SR}$ ^{1,5,6,7} | Slew Rate @ C _{LOAD} = 0 pF | 30 | — | 500 | mV/ns |
| | Slew Rate @ C _{LOAD} = 5 pF | 30 | — | 200 | mV/ns |
| | Slew Rate @ C _{LOAD} = 20 pF | 30 | — | 150 | mV/ns |
| | Slew Rate @ C _{LOAD} = 70 pF | 30 | — | 100 | mV/ns |
| C _{LOAD} | Load Capacitance | 0 | — | 70 | pF |

¹ C_{LOAD} includes the low equivalent transmission line capacitance. The capacitance of TX and RX are assumed to always be < 10 pF. The distributed line capacitance can be up to 50 pF for a transmission line with 2 ns delay.

² The rise-time of TREOT starts from the HS common-level at the moment of the differential amplitude drops below 70 mV, due to stopping the differential drive.

³ With an additional load capacitance CCM between 0 to 60 pF on the termination center tap at RX side of the lane.

⁴ This parameter value can be lower than TLPX due to differences in rise vs. fall signal slopes and trip levels and mismatches between Dp and Dn LP transmitters. Any LP exclusive-OR pulse observed during HS EoT (transition from HS level to LP-11) is glitch behavior as described in Low-Power Receiver section.

⁵ When the output voltage is between 15% and below 85% of the fully settled LP signal levels.

⁶ Measured as average across any 50 mV segment of the output signal transition.

⁷ This value represents a corner point in a piecewise linear curve.

4.10.8.5 MIPI-DSI LP-RX specifications

Table 86. MIPI low power receiver DC specifications

| Symbol | Parameter | Min | Typ | Max | Unit |
|----------------------|---|-----|-----|-----|------|
| V _{IH} | Logic 1 input voltage | 880 | — | 1.3 | mV |
| V _{IL} | Logic 0 input voltage, not in ULP state | — | — | 550 | mV |
| V _{IL-ULPS} | Logic 0 input voltage, ULP state | — | — | 300 | mV |
| V _{HYST} | Input hysteresis | 25 | — | — | mV |

Table 87. MIPI low power receiver AC specifications

| Symbol | Parameter | Min | Typ | Max | Unit |
|-----------------------------------|------------------------------|-----|-----|-----|------|
| e _{SPIKE} ^{1,2} | Input pulse rejection | — | — | 300 | V.ps |
| T _{MIN-RX} ³ | Minimum pulse width response | 20 | — | — | ns |
| V _{INT} | Peak Interference amplitude | — | — | 200 | mV |
| f _{INT} | Interference frequency | 450 | — | — | MHz |

¹ Time-voltage integration of a spike above V_{IL} when in LP-0 state or below V_{IH} when in LP-1 state.

² An impulse below this value will not change the receiver state.

³ An input pulse greater than this value shall toggle the output.

4.10.8.6 MIPI-DSI LP-CD specifications

Table 88. MIPI contention detector DC specifications

| Symbol | Parameter | Min | Typ | Max | Unit |
|------------|------------------------------|-----|-----|-----|------|
| V_{IHCD} | Logic 1 contention threshold | 450 | — | — | mV |
| V_{ILCD} | Logic 0 contention threshold | — | — | 200 | mV |

4.10.8.7 MIPI-DSI DC specifications

Table 89. MIPI input characteristics DC specifications

| Symbol | Parameter | Min | Typ | Max | Unit |
|----------------------|---|-------|-----|------|---------|
| V_{PIN} | Pad signal voltage range | -50 | — | 1350 | mV |
| I_{LEAK}^1 | Pin leakage current | -10 | — | 10 | μ A |
| V_{GNDSH} | Ground shift | -50 | — | 50 | mV |
| $V_{PIN(absmax)}^2$ | Maximum pin voltage level | -0.15 | — | 1.45 | V |
| $T_{VPIN(absmax)}^3$ | Maximum transient time above $V_{PIN(max)}$ or below $V_{PIN(min)}$ | — | — | 20 | ns |

¹ When the pad voltage is within the signal voltage range between $V_{GNDSH(min)}$ to $VOH + V_{GNDSH(max)}$ and the Lane Module is in LP receive mode.

² This value includes ground shift.

³ The voltage overshoot and undershoot beyond the V_{PIN} is only allowed during a single 20 ns window after any LP-0 to LP-1 transition or vice versa. For all other situations it must stay within the V_{PIN} range.

4.10.9 PCIe 3.0 PHY Parameters

The TX and RX eye diagrams specifications are per the template shown in the following figure. The summary of specifications is shown in [Table 90](#) and [Table 91](#). Note that the time closure (1-A OPENING) in the eye templates needs not match jitter specifications in the Standards Specifications, as there are such discrepancies in some Standards Specifications. The design meets the tightest of specifications in case of discrepancy.

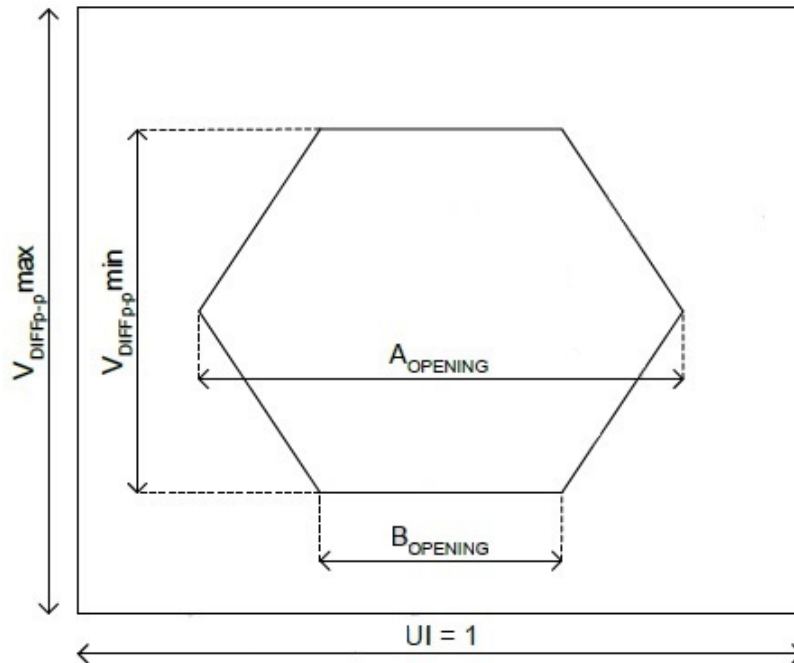

Figure 38. TX and RX eye diagram template

Table 90. PCIe transmitter eye specifications for example standards

| | UI | A _{OPENING} | B _{OPENING} | A _{OPENING} | B _{OPENING} | V _{DIFFp-p} min | V _{DIFFp-p} max |
|-------------------------------------|-----|----------------------|----------------------|----------------------|----------------------|--------------------------|--------------------------|
| | ps | UI | | ps | | mV | |
| PCI Express Gen 1 Transition Bit | 400 | 0.75 | 0 | 300 | 0 | 800 | 1200 ¹ |
| PCI ExpressGen 1 De-emphasized Bit | 400 | 0.75 | 0 | 300 | 0 | 505 | 757 |
| PCI Express Gen 2 Transition Bit | 200 | 0.75 | 0 | 150 | 0 | 800 | 1200 ¹ |
| PCI Express Gen 2 De-emphasized Bit | 200 | 0.75 | 0 | 150 | 0 | 379 | 850 |

¹ V_{DIFFp-p} eye opening is limited to VDDIO under matched termination conditions.

Table 91. PCIe receiver eye specifications for example standards

| | UI | A _{OPENING} | B _{OPENING} | A _{OPENING} | B _{OPENING} | V _{DIFFp-p} min | V _{DIFFp-p} max |
|--|-----|----------------------|----------------------|----------------------|----------------------|--------------------------|--------------------------|
| | ps | UI | | ps | | mV | |
| PCI Express Gen 1 Transition Bit | 400 | 0.4 | 0 | 160 | 0 | 175 | 1200 |
| PCI Express Gen 2 Transition Bit | 200 | 0 | 0 | 0 | 0 | 100 | 1200 |
| PCI Express Gen 3 Virtual EYE ¹ | 125 | 0.3 | 0 | 38 | 0 | 25 | 1300 |

¹ PCIe 3.0 8 GT/s measured using PCIe reference equalizer + CDR per PCIe specification.

Electrical characteristics

Table 92. PCIe differential output driver characteristics (including board and load)

| Parameter | Min | Typ | Max | Units | Notes |
|---|--------------------------|-----------------------|------------------------|--------------|-----------|
| Output Rise and fall time T_R, T_F | 175 | — | 350 | ps | 1 |
| Output Rise/Fall matching | — | — | 20 | % | 1, 2 |
| Output skew T_{OSKEW} | — | — | 50 | ps | — |
| Initialization time from assertion of TXOE | 100 | — | — | ns | — |
| Initialization time from assertion of TXENA | — | 10 | — | μ s | — |
| Transmission line characteristic impedance (Z_O) | — | 50 | — | Ω | — |
| Driver output impedance, single ended (small signal @ $V_{out}=V_{cm}$) | — | 1000 | — | Ω | — |
| Output single ended voltage (RS= 33, RT= 50 Ω) V_{OH} $I_{OH}@ 6 * I_R$ V_{OL} | 0.65 -13 -0.20 | 0.71 -14.2 0.00 | 0.85 -17 0.05 | V mA V | 3, 4 3 |
| Output common mode voltage (RS = 33, RT= 50 Ω) $ V_{OCM} $ $\Delta V_{OCM} (DC)$ $\Delta V_{OCM} (AC)$ | 0.25 -0.015 -0.050 | 0.375 | 0.55 0.015 0.050 | V | 5 6 |
| Buffer induced deterministic jitter (absolute, pk-pk) | — | — | 4 | ps | 7,8 |
| Reference Buffer Dynamic Power (Digital) | — | 0.015 | 0.66 | μ A | 9 |
| Reference Buffer Dynamic Power (Analog) | — | 2.8 | 3.14 | mA | 9 |
| Output Buffer Dynamic Power (Digital) | — | 0.035 | 1.8 | μ A | 9 |
| Output Buffer Dynamic Power (Analog) | — | 18.9 | 22.11 | mA | 9 |

¹ When the output is transitioning between logic 0 and logic 1, or logic 1 and logic 0, and driving a terminated transmission line, the outputs monotonically transition between VOL and VOH, VOH, and VOL respectively. Target rise and fall times observed at the receiver and are primarily set by board trace impedance and Load capacitance. Rise and fall times are defined by 25% and 75% crossing points.

² Calculated as: $2 \times (TR - TF) / (TR + TF)$

³ I_R is proportional to the reference current. Measured across RT. The primary contributor to output voltage spread is VDD spread, and so a VDD tighter than $\pm 10\%$ may be required to achieve this spread.

⁴ Higher output voltages may occur depending on load, power supply, and selected output drive. Higher output voltages may transiently occur during initialization period following TXENA assertion.

⁵ Peak change in output differential voltage when driving a logic 0 and when driving a logic 1 under DC conditions.

⁶ Peak change in output differential voltage when driving a logic 0 and when driving a logic 1 under AC conditions.

⁷ Measured under "clean power supply and ground" conditions, and after de-embedding the jitter of the input, measured over a time span of 1000 cycles

⁸ Power supply induced jitter is included under this category, and the power supply variation is to be less than 8mVpp. Note that customer has to be uncommonly careful with power supply fidelity due to the small jitter numbers.

⁹ Power consumption is simulated under the following conditions:

Typ: TT, VDD=1.0 V, VD18=1.8 V, 25 °C

Max: FF, VDD=1.1 V, VD18=1.98 V, 125 °C

Dynamic: TXENA=1, TXOE=1

Static: TXENA=0, TXOE=1

4.10.9.1 PCIE_REXT reference resistor connection

The following figure shows the PCIE_REXT reference resistor connection.

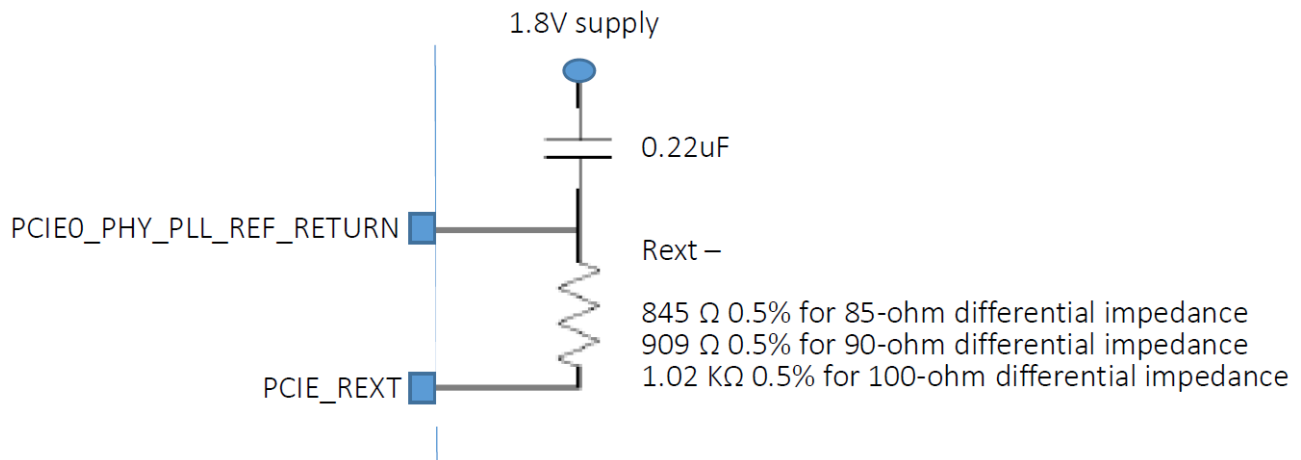

Figure 39. PCIE_REXT reference resistor connection

4.10.9.2 PCIE_REF_CLK

Contact an NXP representative to obtain the hardware development guide for this device, which contains details on the PCIe reference clock requirements.

4.10.10 Pulse Width Modulator (PWM) Timing Parameters

This section describes the electrical information of the PWM. The PWM can be programmed to select one of three clock signals as its source frequency. The selected clock signal is passed through a prescaler before being input to the counter. The output is available at the pulse-width modulator output (PWMO) external pin.

The following figure depicts the timing of the PWM, and [Table 93](#) lists the PWM timing parameters.

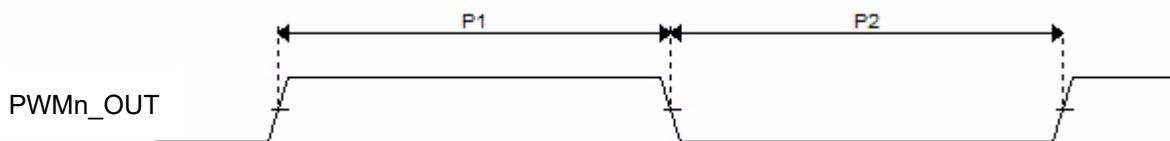

Figure 40. PWM Timing

Table 93. PWM Output Timing Parameters

| ID | Parameter | Min | Max | Unit |
|----|-----------------------------|-----|---------|------|
| — | PWM Module Clock Frequency | 0 | ipg_clk | MHz |
| P1 | PWM output pulse width high | 15 | — | ns |
| P2 | PWM output pulse width low | 15 | — | ns |

4.10.11 LCD controller (LCDIF) parameters

Figure 41 shows the LCDIF timing, and the table below lists the timing parameters.

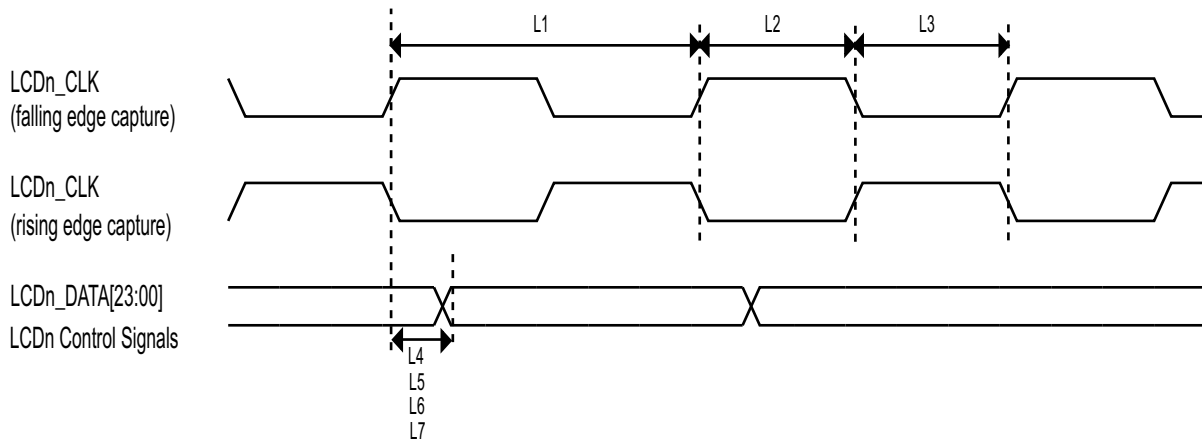

Figure 41. LCD Timing

Table 94. LCD Timing Parameters

| ID | Parameter | Symbol | Min | Max | Unit |
|----|---|----------------|-----|-----|------|
| L1 | LCD pixel clock frequency | tCLK(LCD) | — | 80 | MHz |
| L2 | LCD pixel clock high (falling edge capture) | tCLKH(LCD) | 6 | — | ns |
| L3 | LCD pixel clock low (rising edge capture) | tCLKL(LCD) | 6 | — | ns |
| L4 | LCD pixel clock high to data valid (falling edge capture) | td(CLKH-DV) | -1 | 1 | ns |
| L5 | LCD pixel clock low to data valid (rising edge capture) | td(CLKL-DV) | -1 | 1 | ns |
| L6 | LCD pixel clock high to control signal valid (falling edge capture) | td(CLKH-CTRLV) | -1 | 1 | ns |
| L7 | LCD pixel clock low to control signal valid (rising edge capture) | td(CLKL-CTRLV) | -1 | 1 | ns |

4.10.11.1 LCDIF signal mapping

The table below lists the details about the mapping signals.

Table 95. LCD Signal Parameters

| Pin name | 8-bit DOTCLK LCD IF | 16-bit DOTCLK LCD IF | 18-bit DOTCLK LCD IF | 24-bit DOTCLK LCD IF | 8-bit DVI LCD IF |
|--------------------------|---------------------|----------------------|----------------------|----------------------|------------------|
| LCD_RS | — | — | — | — | CCIR_CLK |
| LCD_VSYNC* (Two options) | LCD_VSYNC | LCD_VSYNC | LCD_VSYNC | LCD_VSYNC | — |
| LCD_HSYNC | LCD_HSYNC | LCD_HSYNC | LCD_HSYNC | LCD_HSYNC | — |

Table 95. LCD Signal Parameters (continued)

| | | | | | |
|-------------------------------|--|-------------------------------------|--|--|--------|
| LCD_DOTCLK | LCD_DOTCLK | LCD_DOTCLK | LCD_DOTCLK | LCD_DOTCLK | — |
| LCD_ENABLE | LCD_ENABLE | LCD_ENABLE | LCD_ENABLE | LCD_ENABLE | — |
| LCD_D23 | — | — | — | R[7] | — |
| LCD_D22 | — | — | — | R[6] | — |
| LCD_D21 | — | — | — | R[5] | — |
| LCD_D20 | — | — | — | R[4] | — |
| LCD_D19 | — | — | — | R[3] | — |
| LCD_D18 | — | — | — | R[2] | — |
| LCD_D17 | — | — | R[5] | R[1] | — |
| LCD_D16 | — | — | R[4] | R[0] | — |
| LCD_D15 / VSYNC* | — | R[4] | R[3] | G[7] | — |
| LCD_D14 / HSYNC** | — | R[3] | R[2] | G[6] | — |
| LCD_D13 / LCD_DOTCLK ** | — | R2[1] | R[1] | G[5] | — |
| LCD_D12 / ENABLE** | — | R[1] | R[0] | G[4] | — |
| LCD_D11 | — | R[0] | G[5] | G[3] | — |
| LCD_D10 | — | G[5] | G[4] | G[2] | — |
| LCD_D9 | — | G[4] | G[3] | G[1] | — |
| LCD_D8 | — | G[3] | G[2] | G[0] | — |
| LCD_D8 | — | G[3] | G[2] | G[0] | — |
| LCD_D7 | R[2] | G[2] | G[1] | B[7] | Y/C[7] |
| LCD_D6 | R[1] | G[1] | G[0] | B[6] | Y/C[6] |
| LCD_D5 | R[0] | G[0] | B[5] | B[5] | Y/C[5] |
| LCD_D4 | G[2] | B[4] | B[4] | B[4] | Y/C[4] |
| LCD_D3 | G[1] | B[3] | B[3] | B[3] | Y/C[3] |
| LCD_D2 | G[0] | B[2] | B[2] | B[2] | Y/C[2] |
| LCD_D1 | B[1] | B[1] | B[1] | B[1] | Y/C[1] |
| LCD_D0 | B[0] | B[0] | B[0] | B[0] | Y/C[0] |
| LCD_RESET | LCD_RESET | LCD_RESET | LCD_RESET | LCD_RESET | — |
| LCD_BUSY / LCD_VSYNC | LCD_BUSY (or optional LCD_VSYNC) | LCD_BUSY (or optional LCD_VSYNC) | LCD_BUSY (or optional LCD_VSYNC) | LCD_BUSY (or optional LCD_VSYNC) | — |

4.10.12 FlexSPI (Quad SPI/Octal SPI) timing parameters

The FlexSPI interface can work in SDR or DDR modes. It can operate up to 60 MHz at 3.3 V, 166 MHz at 1.8 V SDR mode or 200 MHz at 1.8 V DDR mode. It supports single-ended and differential DQS signaling.

FlexSPI supports the following clocking scheme for a read data path:

- Dummy read strobe generated by FlexSPI controller and looped back internally (FlexSPIn_MCR0[RXCLKSRC] = 0x0)
- Dummy read strobe generated by FlexSPI controller and looped back through the DQS pad (FlexSPIn_MCR0[RXCLKSRC] = 0x1). It means the I/O cannot be used for another feature.
- Read strobe provided by memory device and input from DQS pad (FlexSPIn_MCR0[RXCLKSRC] = 0x3)

4.10.12.1 SDR mode

4.10.12.1.1 SDR mode timing diagrams

The following write timing diagram is valid for any FlexSPIn_MCR0[RXCLKSRC] value.

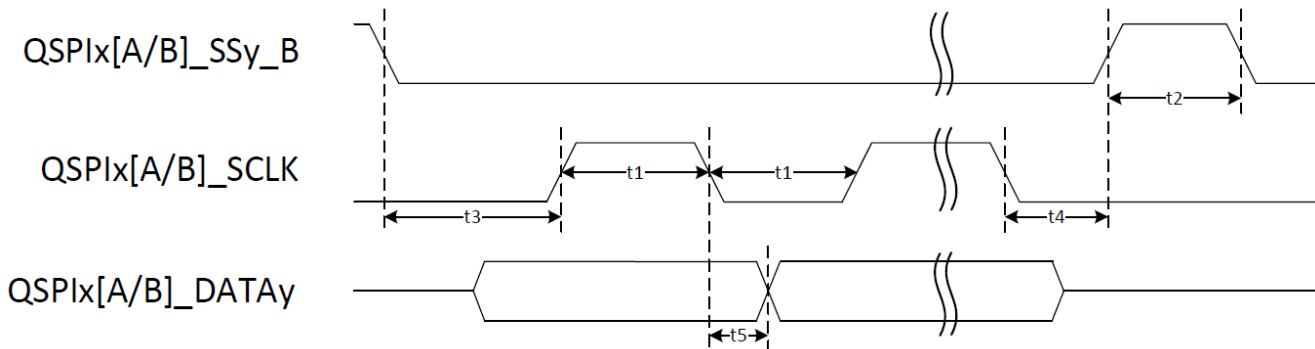

Figure 42. FlexSPI write timing diagram (SDR mode)

The following read timing diagram is valid for FlexSPIn_MCR0[RXCLKSRC] = 0x0 or 0x1.

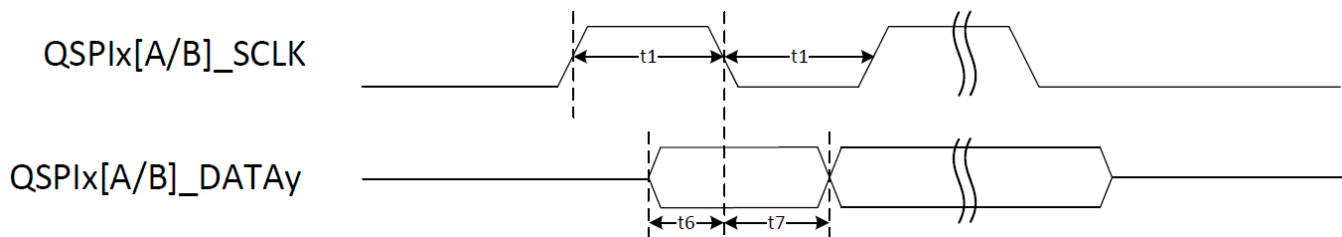

Figure 43. FlexSPI read timing diagram (SDR mode)

The following read timing diagram is valid for FlexSPIn_MCR0[RXCLKSRC] = 0x3.

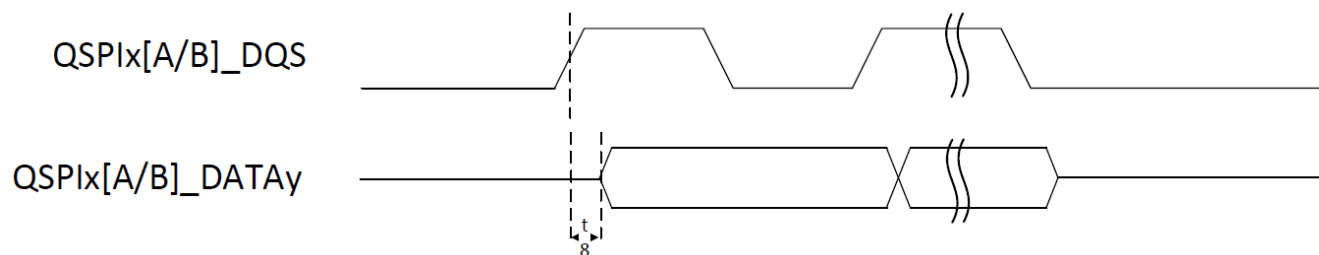

Figure 44. FlexSPI read with DQS timing diagram (SDR mode)

4.10.12.1.2 SDR mode timing parameter tables

Table 96. FlexSPI timings with FlexSPIn_MCR0[RXCLKSRC] = 0x0 (SDR mode)

| ID | Parameter | Min | Max | Unit |
|----|---|----------|-----|------|
| — | QSPiX[A/B]_SCLK Cycle frequency | — | 60 | MHz |
| t1 | QSPiX[A/B]_SCLK High or Low Time | 7.5 | — | ns |
| t2 | QSPiX[A/B]_SSy_B pulse width | 1 | — | SCLK |
| t3 | QSPiX[A/B]_SSy_B Lead Time ¹ | TCSS+0.5 | — | SCLK |
| t4 | QSPiX[A/B]_SSy_B Lag Time ¹ | TCSH | — | SCLK |
| t5 | QSPiX[A/B]_DATAy output Delay | — | 1 | ns |
| t6 | QSPiX[A/B]_DATAy Setup Time | 6 | — | ns |
| t7 | QSPiX[A/B]_DATAy Hold Time | 0 | — | ns |

¹ Timing is controlled from FLSHxCR1 register (x=A1, A2, B1, or B2).

Table 97. FlexSPI timings with FlexSPIn_MCR0[RXCLKSRC] = 0x1 (SDR mode)

| ID | Parameter | Min | Max | Unit |
|----|---|----------|-----|------|
| — | QSPiX[A/B]_SCLK Cycle frequency | — | 166 | MHz |
| t1 | QSPiX[A/B]_SCLK High or Low Time | 2.7 | — | ns |
| t2 | QSPiX[A/B]_SSy_B pulse width | 1 | — | SCLK |
| t3 | QSPiX[A/B]_SSy_B Lead Time ¹ | TCSS+0.5 | — | SCLK |
| t4 | QSPiX[A/B]_SSy_B Lag Time ¹ | TCSH | — | SCLK |
| t5 | QSPiX[A/B]_DATAy output Delay | — | 1 | ns |
| t6 | QSPiX[A/B]_DATAy Setup Time | 1 | — | ns |
| t7 | QSPiX[A/B]_DATAy Hold Time | 2 | — | ns |

Electrical characteristics

¹ Timing is controlled from FLSHxCR1 register (x=A1, A2, B1, or B2).

Table 98. FlexSPI timings with FlexSPIn_MCR0[RXCLKSRC] = 0x3 (SDR mode)

| ID | Parameter | Min | Max | Unit |
|----|---|------------|------|------|
| — | QSPiX[A/B]_DQS Cycle frequency | — | 200 | MHz |
| t1 | QSPiX[A/B]_SCLK High or Low Time | 2.25 | — | ns |
| t2 | QSPiX[A/B]_SSy_B pulse width ¹ | CSINTERVAL | — | SCLK |
| t3 | QSPiX[A/B]_SSy_B Lead Time ² | TCSS+0.5 | — | SCLK |
| t4 | QSPiX[A/B]_SSy_B Lag Time ² | TCSH | — | SCLK |
| t5 | QSPiX[A/B]_DATAy output Delay | — | 1 | ns |
| t8 | QSPiX[A/B]_DQS / QSPiX[A/B]_DATAy delta | -0.65 | 0.65 | ns |

¹ Minimum is 2 SCLK cycles even if CSINTERVAL value is less than 2.

² Timing is controlled from FLSHxCR1 register (x=A1, A2, B1, or B2).

4.10.12.2 DDR mode

4.10.12.2.1 DDR mode timing diagrams

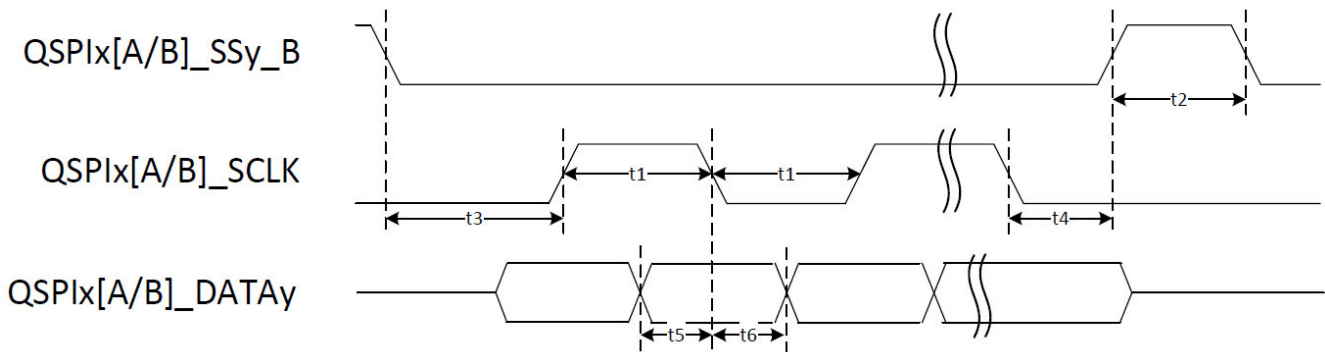

Figure 45. FlexSPI write timing diagram (DDR mode)

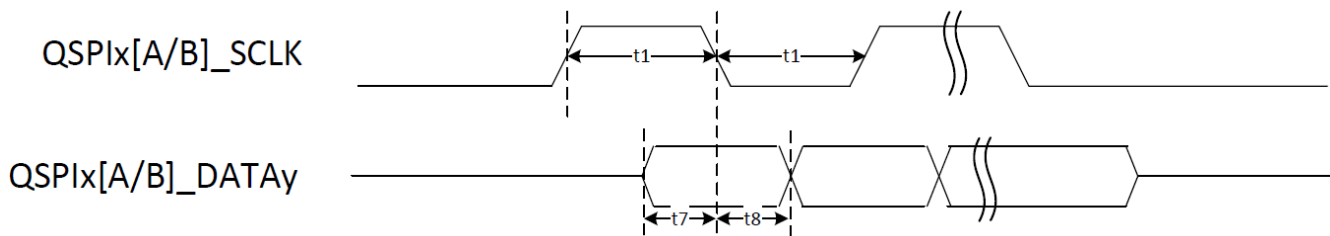

Figure 46. FlexSPI read timing diagram (DDR mode)

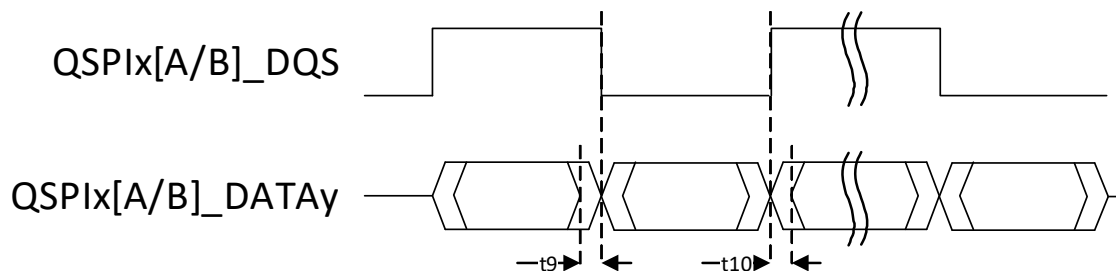

Figure 47. FlexSPI read with DQS timing diagram (DDR mode)

Table 99. FlexSPI timings with FlexSPIn_MCR0[RXCLKSRC] = 0x0 (DDR mode)

| ID | Parameter | Min | Max | Unit |
|----|---|-------------------|-----|------|
| — | QSPIx[A/B]_SCLK Cycle frequency | — | 30 | MHz |
| t1 | QSPIx[A/B]_SCLK High or Low Time | 15 | — | ns |
| t2 | QSPIx[A/B]_SSy_B pulse width | 1 | — | SCLK |
| t3 | QSPIx[A/B]_SSy_B Lead Time ¹ | $(T_{CSS}+0.5)/2$ | — | SCLK |
| t4 | QSPIx[A/B]_SSy_B Lag Time ¹ | $T_{CSH}/2$ | — | SCLK |
| t5 | QSPIx[A/B]_DATAy output valid time | 6.5 | — | ns |
| t6 | QSPIx[A/B]_DATAy output hold time | 6.5 | — | ns |
| t7 | QSPIx[A/B]_DATAy Setup Time | 6 | — | ns |
| t8 | QSPIx[A/B]_DATAy Hold Time | 0 | — | ns |

¹ Timing is controlled from FLSHxCR1 register (x=A1, A2, B1, or B2).

Table 100. FlexSPI timings with FlexSPIn_MCR0[RXCLKSRC] = 0x1 (DDR mode)

| ID | Parameter | Min | Max | Unit |
|----|---|-------------------|-----|------|
| — | QSPIx[A/B]_SCLK Cycle frequency | — | 83 | MHz |
| t1 | QSPIx[A/B]_SCLK High or Low Time | 5.4 | — | ns |
| t2 | QSPIx[A/B]_SSy_B pulse width | 1 | — | SCLK |
| t3 | QSPIx[A/B]_SSy_B Lead Time ¹ | $(T_{CSS}+0.5)/2$ | — | SCLK |
| t4 | QSPIx[A/B]_SSy_B Lag Time ¹ | $T_{CSH}/2$ | — | SCLK |
| t5 | QSPIx[A/B]_DATAy output valid time | 2 | — | ns |
| t6 | QSPIx[A/B]_DATAy output hold time | 2 | — | ns |
| t7 | QSPIx[A/B]_DATAy Setup Time | 1 | — | ns |
| t8 | QSPIx[A/B]_DATAy Hold Time | 1 | — | ns |

¹ Timing is controlled from FLSHxCR1 register (x=A1, A2, B1, or B2).

Table 101. FlexSPI timings with FlexSPI_n_MCR0[RXCLKSRC] = 0x3 (DDR mode)

| ID | Parameter | Min | Max | Unit |
|-----|---|--------------|------|------|
| — | QSPIx[A/B]_SCLK Cycle frequency | — | 200 | MHz |
| t1 | QSPIx[A/B]_SCLK High or Low Time | 2.25 | — | ns |
| t2 | QSPIx[A/B]_SSy_B pulse width | 1 | — | SCLK |
| t3 | QSPIx[A/B]_SSy_B Lead Time ¹ | (TCSS+0.5)/2 | — | SCLK |
| t4 | QSPIx[A/B]_SSy_B Lag Time ¹ | TCSH/2 | — | SCLK |
| t5 | QSPIx[A/B]_DATAy output valid time | 0.65 | — | ns |
| t6 | QSPIx[A/B]_DATAy output hold time | 0.65 | — | ns |
| t9 | QSPIx[A/B]_DATAy Setup Skew | — | 0.65 | ns |
| t10 | QSPIx[A/B]_DATAy Hold Skew | — | 0.65 | ns |

¹ Timing is controlled from FLSHxCR1 register (x=A1, A2, B1, or B2).

4.10.13 Secure JTAG controller (SJC)

4.10.13.1 Internal pull-up/pull-down configuration

The following table describes the default configuration of internal pull-ups and pull-downs of the JTAG interface. External pull-ups and pull-downs are needed when this interface is routed to a connector.

Table 102. JTAG default configuration for internal pull-up/pull-down

| Ball name | Internal pull setting ¹ | Typical pull value | Unit |
|------------------|------------------------------------|--------------------|------|
| JTAG_TMS | PU | 50 | KΩ |
| JTAG_TCK | PD | | |
| JTAG_TDI | PU | | |
| TEST_MODE_SELECT | PD | | |

¹ PU = pull-up; PD = pull-down

4.10.13.2 JTAG timing parameters

Figure 48 depicts the SJC test clock input timing. Figure 49 depicts the SJC boundary scan timing. Figure 50 depicts the SJC test access port. Signal parameters are listed in Table 103.

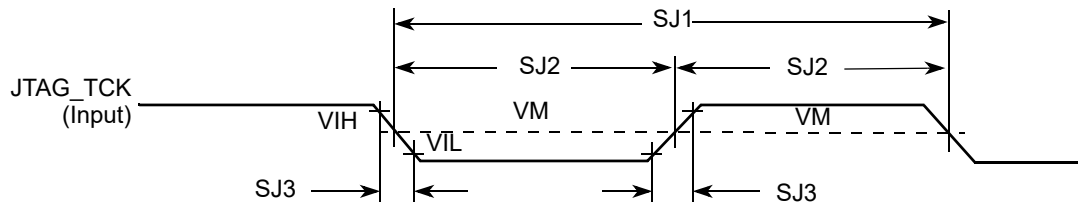

Figure 48. Test Clock Input Timing Diagram

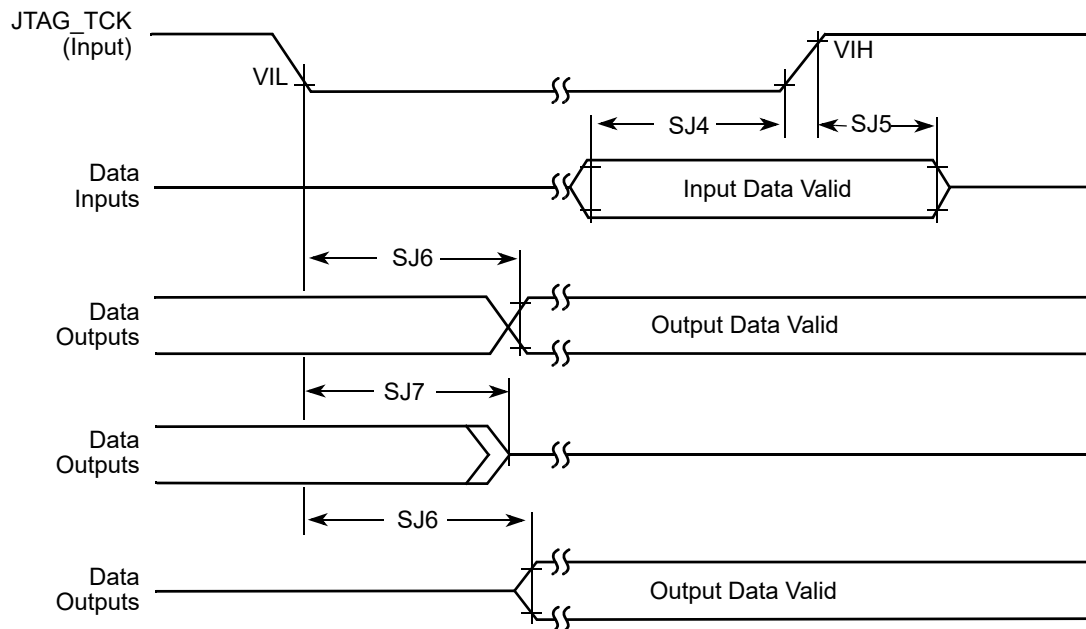

Figure 49. Boundary system (JTAG) timing diagram

Electrical characteristics

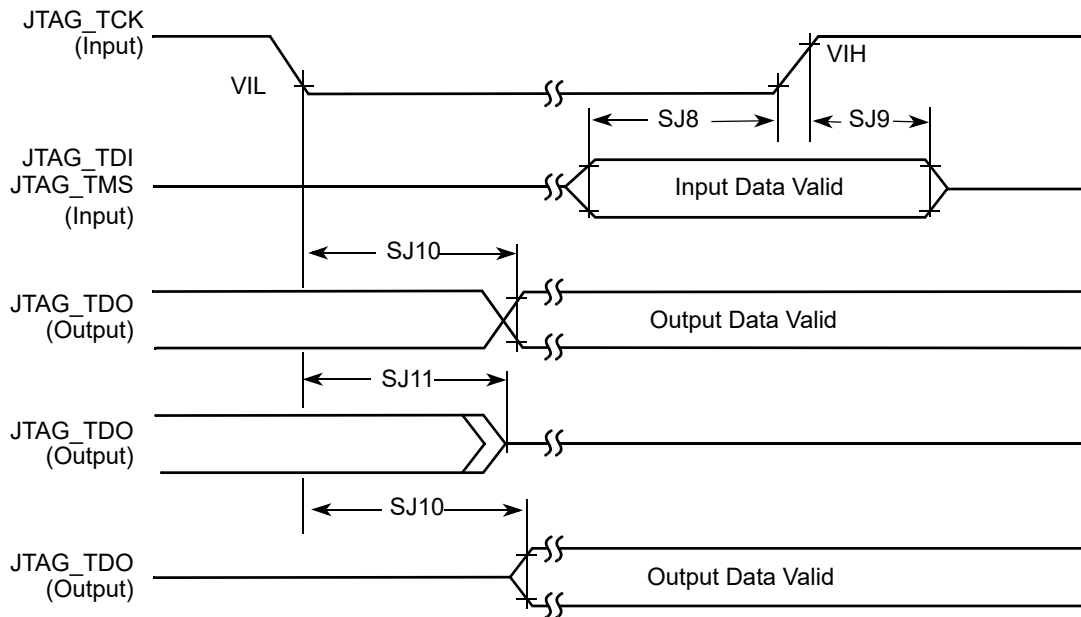

Figure 50. Test Access Port Timing Diagram

Table 103. JTAG Timing

| ID | Parameter ^{1,2} | All Frequencies | | Unit |
|------|---|-----------------|-----|------|
| | | Min | Max | |
| SJ0 | JTAG_TCK frequency of operation $1/(3 \times T_{DC})^1$ | 0.001 | 22 | MHz |
| SJ1 | JTAG_TCK cycle time in crystal mode | 45 | — | ns |
| SJ2 | JTAG_TCK clock pulse width measured at V_M^2 | 22.5 | — | ns |
| SJ3 | JTAG_TCK rise and fall times | — | 3 | ns |
| SJ4 | Boundary scan input data set-up time | 5 | — | ns |
| SJ5 | Boundary scan input data hold time | 24 | — | ns |
| SJ6 | JTAG_TCK low to output data valid | — | 40 | ns |
| SJ7 | JTAG_TCK low to output high impedance | — | 40 | ns |
| SJ8 | JTAG_TMS, JTAG_TDI data set-up time | 5 | — | ns |
| SJ9 | JTAG_TMS, JTAG_TDI data hold time | 25 | — | ns |
| SJ10 | JTAG_TCK low to JTAG_TDO data valid | — | 44 | ns |
| SJ11 | JTAG_TCK low to JTAG_TDO high impedance | — | 44 | ns |

¹ T_{DC} = target frequency of SJC

² V_M = mid-point voltage

4.10.14 SPDIF Timing Parameters

The Sony/Philips Digital Interconnect Format (SPDIF) data is sent using the bi-phase marking code. When encoding, the SPDIF data signal is modulated by a clock that is twice the bit rate of the data signal.

Table 104, Figure 51, and Figure 52 show SPDIF timing parameters for the Sony/Philips Digital Interconnect Format (SPDIF), including the timing of the modulating Rx clock (SPDIF_SR_CLK) for SPDIF in Rx mode and the timing of the modulating Tx clock (SPDIF_ST_CLK) for SPDIF in Tx mode.

Table 104. SPDIF Timing Parameters

| Parameter | Symbol | Timing Parameter Range | | Unit |
|--|--------|------------------------|------|------|
| | | Min | Max | |
| SPDIF_IN Skew: asynchronous inputs, no specs apply | — | — | 0.7 | ns |
| SPDIF_OUT output (Load = 50pf) | | | | |
| • Skew | — | — | 1.5 | ns |
| • Transition rising | — | — | 24.2 | |
| • Transition falling | — | — | 31.3 | |
| SPDIF_OUT output (Load = 30pf) | | | | |
| • Skew | — | — | 1.5 | ns |
| • Transition rising | — | — | 13.6 | |
| • Transition falling | — | — | 18.0 | |
| Modulating Rx clock (SPDIF_SR_CLK) period | srckp | 40.0 | — | ns |
| SPDIF_SR_CLK high period | srckph | 16.0 | — | ns |
| SPDIF_SR_CLK low period | srckpl | 16.0 | — | ns |
| Modulating Tx clock (SPDIF_ST_CLK) period | stckp | 40.0 | — | ns |
| SPDIF_ST_CLK high period | stckph | 16.0 | — | ns |
| SPDIF_ST_CLK low period | stckpl | 16.0 | — | ns |

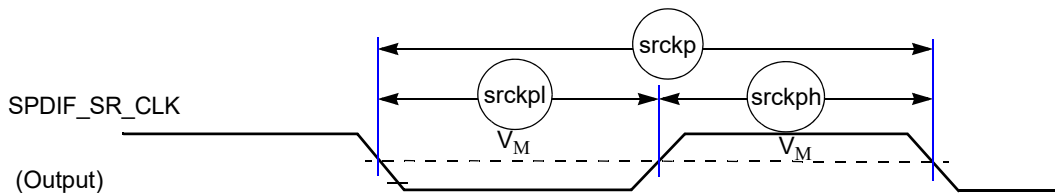

Figure 51. SPDIF_SR_CLK Timing Diagram

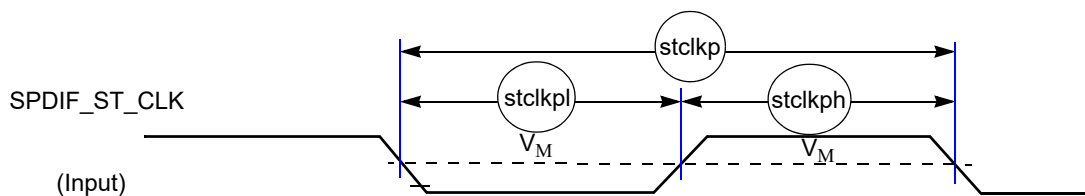

Figure 52. SPDIF_ST_CLK Timing Diagram

4.10.15 UART I/O configuration and timing parameters

4.10.15.0.1 UART Transmitter

The following figure depicts the transmit timing of UART in the RS-232 serial mode, with 8 data bit/1 stop bit format. Table 105 lists the UART RS-232 serial mode transmit timing characteristics.

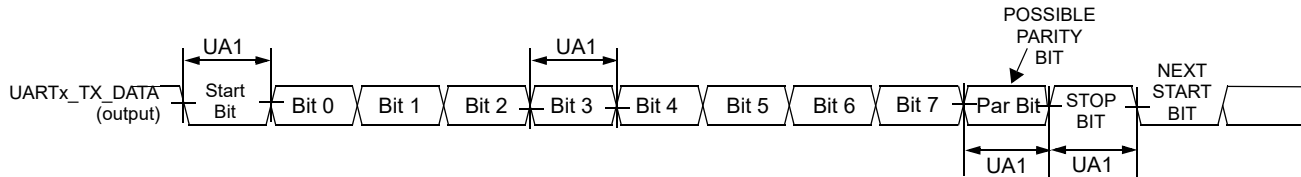

Figure 53. UART RS-232 Serial Mode Transmit Timing Diagram

Table 105. UART RS-232 Serial Mode Transmit Timing Parameters

| ID | Parameter | Symbol | Min | Max | Unit |
|-----|-------------------|------------|---------------------------------------|-----------------------------------|------|
| UA1 | Transmit Bit Time | t_{Tbit} | $1/F_{baud_rate}^1 - T_{ref_clk}^2$ | $1/F_{baud_rate} + T_{ref_clk}$ | — |

¹ F_{baud_rate} : Baud rate frequency. The maximum baud rate the UART can support is (LPUART_clk frequency)/(SBR[12:0] × (OSR+1)).

² T_{ref_clk} : The period of UART reference clock ref_clk (LPUART_clk after SBR divider).

4.10.15.0.2 UART Receiver

The following figure depicts the RS-232 serial mode receive timing with 8 data bit/1 stop bit format. Table 106 lists serial mode receive timing characteristics.

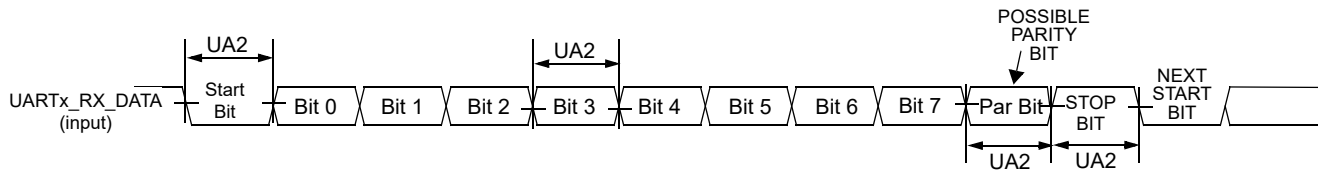

Figure 54. UART RS-232 Serial Mode Receive Timing Diagram

Table 106. RS-232 Serial Mode Receive Timing Parameters

| ID | Parameter | Symbol | Min | Max | Unit |
|-----|-------------------------------|------------|---|---|------|
| UA2 | Receive Bit Time ¹ | t_{Rbit} | $1/F_{baud_rate}^2 - 1/(16 \times F_{baud_rate})$ | $1/F_{baud_rate} + 1/(16 \times F_{baud_rate})$ | — |

¹ The UART receiver can tolerate $1/((OSR+1) \times F_{baud_rate})$ tolerance in each bit, but accumulation tolerance in one frame must not exceed $3/((OSR+1) \times F_{baud_rate})$.

² F_{baud_rate} : Baud rate frequency. The maximum baud rate the UART can support is (LPUART_clk frequency)/(SBR[12:0] × (OSR+1)).

4.10.15.0.3 UART IrDA Mode Timing

The following subsections give the UART transmit and receive timings in IrDA mode.

UART IrDA Mode Transmitter

The following figure depicts the UART IrDA mode transmit timing, with 8 data bit/1 stop bit format. Table 107 lists the transmit timing characteristics.

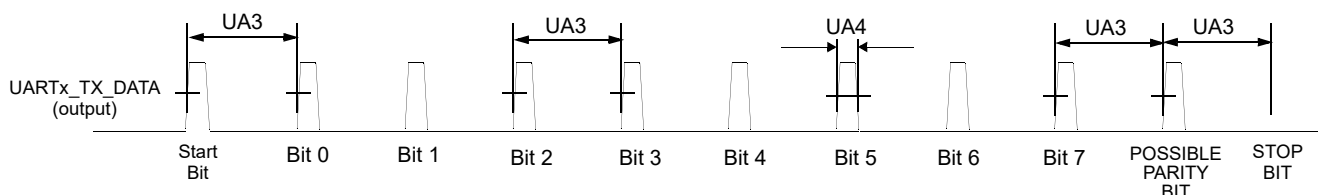

Figure 55. UART IrDA Mode Transmit Timing Diagram

Table 107. IrDA Mode Transmit Timing Parameters

| ID | Parameter | Symbol | Min | Max | Unit |
|-----|--------------------------------|----------------|--|--|------|
| UA3 | Transmit Bit Time in IrDA mode | t_{TIRbit} | $1/F_{baud_rate}^1 - T_{ref_clk}^2$ | $1/F_{baud_rate} + T_{ref_clk}$ | — |
| UA4 | Transmit IR Pulse Duration | $t_{TIRpulse}$ | $(TNP+1)/(OSR+1) \times (1/F_{baud_rate} - T_{ref_clk})$ | $(TNP+1)/(OSR+1) \times (1/F_{baud_rate} + T_{ref_clk})$ | — |

¹ F_{baud_rate} : Baud rate frequency. The maximum baud rate the UART can support is $(LPUART_clk \text{ frequency}) / (SBR[12:0] \times (OSR+1))$.

² T_{ref_clk} : The period of UART reference clock ref_clk (LPUART_clk after SBR divider).

UART IrDA Mode Receiver

The following figure depicts the UART IrDA mode receive timing, with 8 data bit/1 stop bit format. Table 108 lists the receive timing characteristics.

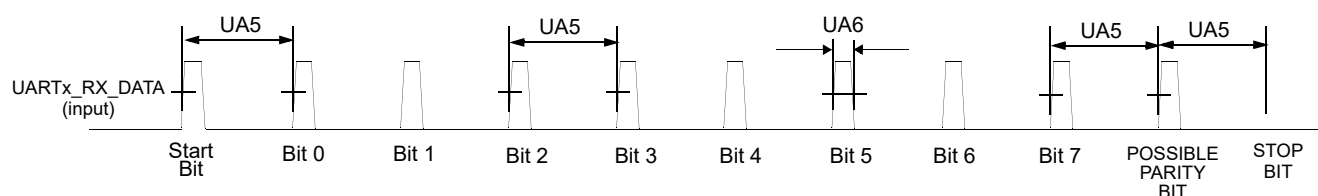

Figure 56. UART IrDA Mode Receive Timing Diagram

Table 108. IrDA Mode Receive Timing Parameters

| ID | Parameter | Symbol | Min | Max | Unit |
|-----|--|----------------|---|---|------|
| UA5 | Receive Bit Time ¹ in IrDA mode | t_{RIRbit} | $1/F_{baud_rate}^2 - 1/(16 \times F_{baud_rate})$ | $1/F_{baud_rate} + 1/(16 \times F_{baud_rate})$ | — |
| UA6 | Receive IR Pulse Duration | $t_{RIRpulse}$ | 1.41 μ s | $(5/16) \times (1/F_{baud_rate})$ | — |

¹ The UART receiver can tolerate $1/((OSR+1) \times F_{baud_rate})$ tolerance in each bit. But accumulation tolerance in one frame must not exceed $3/((OSR+1) \times F_{baud_rate})$.

Electrical characteristics

² Fbaud_rate: Baud rate frequency. The maximum baud rate the UART can support is (LPUART_clk frequency)/(SBR[12:0] × (OSR+1)).

4.10.16 USB 2.0 PHY Parameters

4.10.16.1 USB 2.0 PHY Transmitter specifications

This section describes the transmitter specifications for USB2.0 PHY.

4.10.16.1.1 USB 2.0 PHY full-speed/low-speed transmitter specifications

The following table lists the full-speed/low-speed (FS/LS) transmitter specifications for USB2.0 PHY.

Table 109. USB 2.0 PHY FS/LS transmitter specifications

| Symbol | Description | Min | Typ | Max | Units |
|--------|---|------|-----|--------|-------|
| VOL | Output Voltage Low | 0 | — | 0.3 | V |
| VOH | Output Voltage High (Driven) | 2.8 | — | 3.6 | V |
| VOSE1 | Single Ended One (SE1) | 0.8 | — | — | V |
| VCRS | Output Signal Cross Over Voltage | 1.3 | — | 2.0 | V |
| TFR | Driver Rise Time - FS | 4 | — | 20 | ns |
| TLR | Driver Rise Time - LS | 75 | — | 300 | ns |
| TFF | Driver Fall Time - FS | 4 | — | 20 | ns |
| TLF | Driver Fall Time - LS | 75 | — | 300 | ns |
| TFRFM | Differential Rise and Fall Time Matching - FS | 90 | — | 111.11 | % |
| TLRFM | Differential Rise and Fall Time Matching - LS | 80 | — | 125 | % |
| ZHSDRV | Driver Output Resistance (Also serves as HS Termination) | 40.5 | — | 49.5 | Ω |
| TDJ1 | Source Jitter (Next Transition) - FS | -3.5 | — | 3.5 | ns |
| TDJ2 | Source Jitter (Paired Transition) - FS | -4 | — | 4 | ns |
| TFDEOP | Source Jitter (Differential to SE0 transition) - FS | -2 | — | 5 | ns |
| TFOPT | Source SE0 interval of EOP - FS | 160 | — | 175 | ns |
| TDDJ1 | Source Jitter in downstream direction (Next Transition) - LS | -25 | — | 25 | ns |
| TDDJ2 | Source Jitter in downstream direction (Paired Transition) - LS | -14 | — | 14 | ns |
| TUDJ1 | Source Jitter in upstream direction (Next Transition) - LS | -95 | — | 95 | ns |
| TUDJ2 | Source Jitter in upstream direction (Paired Transition) - LS | -150 | — | 150 | ns |
| TLDEOP | Source Jitter in upstream direction (Differential to SE0 transition) - LS | -40 | — | 100 | ns |
| TLEOPT | Source SE0 interval of EOP - LS | 1.25 | — | 1.5 | μs |

4.10.16.2 USB 2.0 PHY high-speed transmitter specifications

The following table lists the high-speed (HS) transmitter specifications for USB 2.0 PHY.

Table 110. USB 2.0 PHY HS transmitter specifications

| Symbol/Parameter | Description | Min | Typ | Max | Units |
|----------------------------|---|------|-----|--------|-------|
| HSOI | High Speed Idle Level | -10 | — | 10 | mV |
| VHSTERM | Termination Voltage in High Speed | -10 | — | 10 | mV |
| VHSOL | High Speed Data Signaling Low | -10 | — | 10 | mV |
| VCHIRPJ | Chirp J (Differential Voltage) | 700 | — | 1100 | mV |
| VCHIRPK | Chirp K (Differential Voltage) | -900 | — | -500 | mV |
| ZHSDRV | Driver Output Resistance | 40.5 | — | 49.5 | Ω |
| THSR | Rise Time (10% to 90%) | 100 | — | — | ps |
| THSF | Fall Time (10% to 90%) | 100 | — | — | ps |
| HS Eye Opening: Template 1 | Differential eye opening at 37.5% US and 62.5% UI for a hub measured at TP2 and for a device without a captive cable measured at TP3. | -300 | — | 300 | mV |
| HS Eye Opening: Template 2 | Differential eye opening at 37.5% US and 62.5% UI for a device with a captive cable measured at TP2. | -175 | — | 175 | mV |
| HS Jitter: Template 1 | Peak-Peak Jitter at Zero crossing for a hub measured at TP2 and for a device without captive cable measured at TP3. | — | — | 15 | %UI |
| | | — | — | 312.5 | ps |
| HS Jitter: Template 2 | Peak-Peak Jitter at Zero crossing for a device with captive cable measured at TP2. | — | — | 25 | %UI |
| | | — | — | 520.83 | ps |

4.10.16.3 USB 2.0 PHY receiver specifications

This section describes the receiver specifications implemented in USB 2.0 PHY.

4.10.16.3.1 USB 2.0 PHY full-speed/low-speed (FS/LS) receiver specifications

Table 111. USB 2.0 PHY FS/LS receiver specifications

| Symbol | Description | Min | Typ | Max | Units |
|--------|---|-------|-----|------|-------|
| VIH | Input Voltage Level - High (Driven) | 2 | — | — | V |
| VIHZ | Input Voltage Level - High (Floating) | 2.7 | — | 3.6 | V |
| VIL | Input Voltage Level - Low | — | — | 0.8 | V |
| VTH | Switching Threshold | 0.8 | — | 2.0 | V |
| VCM | Common Mode Range | 0.8 | — | 2.5 | V |
| TJR1 | Receiver Jitter Budget (Next Transition) - FS | -18.5 | — | 18.5 | ns |

Electrical characteristics

Table 111. USB 2.0 PHY FS/LS receiver specifications (continued)

| Symbol | Description | Min | Typ | Max | Units |
|--------|---|------|-----|-----|-------|
| TJR2 | Receiver Jitter Budget (Paired Transition) - FS | -9 | — | 9 | ns |
| TFEOPR | Receiver EOP Interval of EOP - FS | 82 | — | — | ns |
| TUJR1 | US Port Differential Receiver Jitter (Next Transition) - LS | -152 | — | 152 | ns |
| TUJR2 | US Port Differential Receiver Jitter (Paired Transition) - LS | -200 | — | 200 | ns |
| TDJR1 | DS Port Differential Receiver Jitter (Next Transition) - LS | -75 | — | 75 | ns |
| TDJR2 | DS Port Differential Receiver Jitter (Paired Transition) - LS | -45 | — | 45 | ns |
| TLEOPR | Receiver EOP Interval of EOP - LS | 670 | — | — | ns |

4.10.16.3.2 USB 2.0 PHY high-speed receiver specifications

The following table lists the high-speed (HS) receiver specifications for USB 2.0 PHY.

Table 112. USB 2.0 PHY HS receiver specifications

| Symbol/Parameter | Description | Min | Typ | Max | Units |
|------------------------------------|--|------|-----|--------|----------|
| VHSCM | HS RX input common mode voltage range. | -50 | — | 500 | mV |
| ZHSDRV | HS RX input termination (Same as Driver output resistance). | 40.5 | — | 49.5 | Ω |
| HSRX Jitter: Template 3 | HS RX Peak-Peak Jitter specification at differential zero crossing for a device with captive cable when signal applied at TP2. | — | — | 20 | %UI |
| | | — | — | 416.66 | ps |
| HSRX Jitter: Template 4 | HS RX Peak-Peak Jitter specification at differential zero crossing for a device without captive cable at TP3 and for a hub at TP2. | — | — | 30 | %UI |
| | | — | — | 625 | ps |
| HSRX Input Eye Opening: Template 3 | HS RX differential sensitivity specification at 40% and 60% UI for a device with captive cable when signal is applied at TP2. | -275 | — | 275 | mV |
| HSRX Input Eye Opening: Template 4 | HS RX differential sensitivity specification at 35% and 65% UI for a device without captive cable when signal is applied at TP3 and for a hub when a signal is applied at TP2. | -150 | — | 150 | mV |

4.10.16.3.3 USB 2.0 PHY high-speed envelope detector specifications

The following table lists the high-speed (HS) Envelope Detector Specifications of USB 2.0 PHY.

Table 113. USB 2.0 PHY HS envelope detector specifications

| Symbol | Description | Min | Typ | Max | Units |
|--------|---|-----|-----|-----|-------|
| VHSSQ | HS Squelch Detection threshold (differential signal amplitude) | 100 | — | 150 | mV |
| VHSDSC | HS Disconnect Detection threshold (differential signal amplitude) | 525 | — | 625 | mV |

4.10.16.4 USB 2.0 PHY full-speed/high-speed terminations specification

The following table lists the full-speed/low-speed (FS/LS) Terminations Specification of USB 2.0 PHY.

Table 114. USB 2.0 PHY FS/LS terminations specification

| Symbol | Description | Min | Typ | Max | Units |
|--------|---|-------|-----|------|------------|
| RPU | Bus Pull-Up resistor on US Port in IDLE State | 900 | — | 1575 | Ω |
| | Bus Pull-Up resistor on US Port in ACTIVE State | 1425 | — | 3090 | Ω |
| RPD | Bus Pull-Down resistor on DS Port | 14.25 | — | 24.8 | K Ω |
| VTERM | Termination Voltage for US Port Pull-Up (RPU) | 3.0 | — | 3.6 | V |

4.10.16.5 Voltage threshold specification

The following table lists the OTG Comparator Specifications of USB2.0 PHY.

Table 115. USB 2.0 PHY OTG comparator specifications

| Symbol | Description | Min | Typ | Max | Units |
|-----------|----------------------------------|-----|-----|------|-------|
| sessvld | B-Device Session Valid threshold | 0.8 | — | 4.0 | V |
| vbusvalid | VBUS Valid threshold | 4.4 | — | 4.75 | V |

4.10.17 USB 3.0 PHY parameters

The following content is from the USB 3.0 PHY specifications.

4.10.17.1 USB 3.0 PHY external component

Table 116. USB 3.0 PHY external component specifications

| Name | Min | Typ | Max | Units | Descriptions |
|------|-------|-----|-------|----------|---|
| rext | 497.5 | 500 | 502.5 | Ω | There needs to be an external resistor component connected at rext ball while the internal resistor or current is getting calibrated. Package routing from rext ball to its respective bump should not contribute more than 0.05 Ω . |

4.10.17.2 USB 3.0 PHY transmitter module

Table 117. USB 3.0 PHY transmitter module electrical specifications

| Symbol | Description | Min | Typ | Max | Unit |
|-----------------------------------|---|--------|-----|---|----------|
| Voltage/current parameters | | | | | |
| $V_{TX-DIFFp}$ | Programmable output voltage swing (single-ended) | 50 | — | 500 | mV |
| $V_{TX-DIFFp-p}$ | Programmable differential peak-to-peak output voltage | 100 | — | 1000 | mV |
| $V_{TX-DIFFp-p-LOW}^1$ | Low power differential p-p TX voltage swing | 400 | — | 1200 | mV |
| $I_{TX-SHORT}$ | Transmit lane short-circuit current | — | — | 100 | mA |
| $RL_{TX-DIFF}$ | Transmitter differential return loss | — | — | 0 < -20dB < 100Mhz 100Mhz < -18dB < 300Mhz 300Mhz < -16dB < 600Mhz 600Mhz < -10dB < 2500Mhz 2500Mhz < -9dB < 4875Mhz 4875Mhz < -8dB < 11200Mhz 11200Mhz < -5dB < 16800Mhz and -3dB beyond that | Db |
| RL_{TX-CM} | Transmitter common mode return loss | — | — | 50Hz < -8dB < 15000Mhz | dB |
| $Z_{TX-DIFF-DC}$ | DC differential TX impedance | 80 | 100 | 120 | Ω |
| UI | Unit Interval | 199.94 | — | 200.06 | ps |
| $T_{TX-MAX-JITTER}$ | Transmitter total jitter (peak-to-peak) (T_j) | — | — | 0.4 | UI |
| $T_{TX-RJ-PLL-sigma}$ | After application of TX jitter transfer function | — | — | 2.42 | ps |
| LTLAT-10 | Transmitter data latency | — | — | 210 | UI |
| Voltage parameters | | | | | |
| $V_{TX-CM-DC-ACTIVE-IDLE-DELTA}$ | Absolute Delta of DC Common Mode Voltage during L0 and Electrical Idle. | 0 | — | 100 | mV |
| $V_{TX-IDLE-DIFF-AC-p}$ | Electrical Idle Differential Peak Output Voltage | 0 | — | 20 | mV |
| $V_{TX-CM-DC-LINE-DELTA}$ | Absolute Delta of DC Common Mode Voltage between D+ and D- | 0 | — | 25 | mV |
| $V_{TX-RCV-DETECT}$ | The amount of voltage change allowed during Receiver Detection | 0 | — | 600 | mV |
| $T_{TX-IDLE-SET-TO-IDLE}$ | Maximum time to transition to a valid Electrical Idle after sending an EIOS | — | — | 8 | ns |

Table 117. USB 3.0 PHY transmitter module electrical specifications (continued)

| Symbol | Description | Min | Typ | Max | Unit |
|----------------------------|--|------|-----|------|--------------|
| $T_{TX-IDLE-TO-DIFF-DATA}$ | Maximum time to transition to valid diff signaling after leaving Electrical Idle | — | — | 8 | ns |
| $V_{TX-CM-AC-PP}$ | Tx AC peak-peak common mode voltage (5.0 GT/s) | 20 | — | 150 | mVpp |
| T_{EIExit} | Time to exit Electrical Idle (L0s) state and to enter L0 | — | — | 5 | Txsysclk |
| Tx signal characteristics | | | | | |
| f_{tol} | TX Frequency Long Term Accuracy | -300 | — | 300 | ppm of Fbaud |
| f_{SSC} | Spread-Spectrum Modulation Frequency | 30 | — | 33 | kHz |
| $t_{20-80TX}$ | TX Rise/Fall Time | 0.2 | — | 0.41 | UI |
| t_{skewTX} | TX Differential Skew | — | — | 20 | ps |

¹ For USB 3.0, no EQ is required

4.10.17.3 USB 3.0 PHY receiver module

Table 118. USB 3.0 PHY receiver module electrical specifications

| Symbol | Description | Min | Typ | Max | Unit | Comments |
|-----------------------------|---|---------------|-----|------|-------|--|
| Voltage Parameters | | | | | | |
| $V_{RX-DIFF(p-p)}$ | Differential input voltage (peak-to-peak) (that is, receiver eye voltage opening) | 100 | — | 1200 | mV | — |
| $V_{RX-IDLE-DET-DIFF(p-p)}$ | Differential input threshold voltage (peak-to-peak) to detect idle (LFPS) | 100 | — | 300 | mV | USB3 LFPS |
| $V_{cm, acRX}$ | RX AC Common Mode Voltage | — | — | 100 | mVp-p | Simulated at 250 MHz |
| $V_{RX-CM-AC}$ | Receiver common-mode voltage for AC coupling | — | 0 | 150 | mV | — |
| $Z_{RX-DIFF-DC}$ | Differential input impedance (DC) | 80 | 100 | 120 | W | 100 $\Omega \pm 10\%$ |
| $RL_{RX-DIFF}$ | Receiver differential return loss | Same as TX RL | — | — | dB | — |
| Jitter Parameters | | | | | | |
| $T_{RX-MAX-JITTER}$ | Receiver total jitter tolerance | 0 | — | 0.66 | UI | Incoming Jitter: USB3 = 0.43UI DJ + 0.23UI RJ USB3 numbers are with REFC-TLE |

Table 119. PLL module electrical specifications

| Parameter | Symbol | Description | Min | Typ | Max | Units |
|------------------------------------|---------------------|---|-------|--------------------|------|--------|
| Input Reference Clock | | | | | | |
| REF CLK Frequency | REF CLK | — | 19.2 | 19.2/24/25/26/38.4 | 38.4 | MHz |
| REF CLK Duty Cycle | — | — | 47 | — | 53 | MHz |
| REF CLK Frequency | REF CLK | — | 40 | 40/48/50/52/100 | 100 | MHz |
| REF CLK RJ Tolerance | — | Integrated jitter from 10 kHz to 16 MHz after applying appropriate PLL ref clock transfer function and the protocol JTF | — | — | 0.5 | ps |
| REF CLK Duty Cycle | — | — | 37 | — | 63 | % |
| Divided Reference Frequency | — | — | 19.2 | — | 38.4 | MHz |
| Dividers | | | | | | |
| Input division | IPDIV<7:0> | — | 1 | — | 255 | Counts |
| Feedback division | pll_fbdiv_high<9:0> | — | 2 | — | 1025 | Counts |
| | pll_fbdiv_low<9:0> | — | 2 | — | 1025 | Counts |
| Feedback fractional division range | — | — | >-2 | — | <2 | Counts |
| Number of fractional bits | — | This includes one bit for sign | — | 27 | — | Bits |
| VCO | | | | | | |
| Clock frequency | — | Output full rate clocks | — | 5000 | — | MHz |
| VCO frequency | — | VCO oscillation frequency | — | 5000 | — | MHz |
| Output clock frequency tolerance | — | This includes SSC deviation | -5300 | — | 300 | ppm |
| SSC modulation rate | — | As applicable for USB3.0 | 30 | — | 33 | kHz |
| Output clock RJ sigma for TX | — | After application of TX jitter transfer function | — | — | 2.42 | ps |
| Output clock RJ sigma for RX | — | After application of RX jitter transfer function | — | — | 1.40 | ps |

4.11 Analog-to-digital converter (ADC)

The following table shows the ADC electrical specifications for VREFH=VDD_ADC_1P8.

Table 120. ADC electrical specifications (VREFH=VDD_ADC_1P8)

| Symbol | Description | Min | Typ ¹ | Max | Unit | Notes |
|--------------------------|----------------------------------|--|------------------|--------------|--------|-------|
| V _{ADIN} | Input Voltage | VREFL | — | VREFH | V | — |
| C _{ADIN} | Input capacitance | — | 4.5 | — | pF | — |
| R _{ADIN} | Input Resistance | — | 500 | — | Ω | — |
| R _{AS} | Analog Source Resistance | — | — | 5 | kΩ | 2 |
| f _{ADCK} | ADC Conversion Clock Frequency | — | 24 | — | MHz | — |
| C _{sample} | Sample cycles | 3.5 | — | 131.5 | — | 3 |
| C _{compare} | Fixed compare cycles | — | 17.5 | — | cycles | — |
| C _{conversion} | Conversion cycles | C _{conversion} = C _{sample} + C _{compare} | | | cycles | — |
| DNL | Differential Non-Linearity | — | ± 0.6 | -0.5 to +1.1 | LSB | 4 |
| INL | Integral Non-Linearity | — | ± 0.9 | ±1.1 | LSB | 4 |
| ENOB | Effective Number of Bits | — | — | — | — | 5,6,7 |
| | Avg = 1 | 10.1 | 10.4 | — | Bits | |
| | Avg = 2 | 10.5 | 10.7 | — | Bits | |
| | Avg = 16 | 11.1 | 11.3 | — | Bits | |
| SINAD | Signal to Noise plus Distortion | SINAD=6.02 x ENOB + 1.76 | | | dB | — |
| E _G | Gain error | — | -0.29 | — | %FSV | 8 |
| E _O | Offset error | — | 0.01 | — | %FSV | 9 |
| I _{VDDA18} | Supply Current | — | 480 | — | μA | 10 |
| I _{in,ext,leak} | External Channel Leakage Current | — | 30 | 500 | nA | — |
| E _{IL} | Input leakage error | RAS * I _{in} | | | mV | — |

¹ Typical values assume VDD_ADC_1P8 = 1.8 V, Temp = 25 °C, f_{ACLK} = Max, unless otherwise stated. Typical values are for reference only. All values, including Min and Max, are derived from lab characterization and are not tested in production.

² This resistance is external to the input pad. To achieve the best results, the analog source resistance must be kept as low as possible. The results in this data sheet were derived from a system that had < 15 Ω analog source resistance. The RAS/CAS (analog source capacitance) time constant should be kept to < 1 ns.

³ See [Figure 57](#).

⁴ ADC conversion clock at max frequency and using linear histogram.

⁵ Input data used for test was 1 kHz sine wave.

⁶ Measured at VREFH = 1.8 V and pwrsel = 2.

⁷ ENOB can be lower than shown, if an ADC channel corrupts other ADC channels through capacitive coupling. This coupling may be dominated by board parasitics. Care must be taken not to corrupt the desired channel being measured. This coupling becomes worse at higher analog frequencies and with switching waveforms due to the harmonic content.

⁸ Error measured at fullscale at 1.8 V.

⁹ Error measured at zero scale at 0 V.

Electrical characteristics

¹⁰ Power Configuration Select, PWRSEL, is set to 10 binary.

The following table shows the ADC electrical specifications for $1V \leq VREFH < VDD_ADC_1P8$.

Table 121. ADC electrical specifications ($1V \leq VREFH < VDD_ADC_1P8$)

| Symbol | Description | Min | Typ ¹ | Max | Unit | Notes |
|--------------------------|----------------------------------|---|------------------|--------------|--------|-------|
| V _{ADIN} | Input Voltage | VREFL | — | VREFH | V | — |
| C _{ADIN} | Input capacitance | — | 4.5 | — | pF | — |
| R _{ADIN} | Input Resistance | — | 500 | — | Ω | — |
| R _{AS} | Analog Source Resistance | — | — | 5 | kΩ | 2 |
| f _{ADCK} | ADC Conversion Clock Frequency | — | 24 | — | MHz | — |
| C _{sample} | Sample cycles | 3.5 | — | 131.5 | — | 3 |
| C _{compare} | Fixed compare cycles | — | 17.5 | — | cycles | — |
| C _{conversion} | Conversion cycles | $C_{conversion} = C_{sample} + C_{compare}$ | | | cycles | — |
| DNL | Differential Non-Linearity | — | ± 0.6 | -0.5 to +1.1 | LSB | 4 |
| INL | Integral Non-Linearity | — | ± 0.9 | ±1.1 | LSB | 4 |
| ENOB | Effective Number of Bits | — | — | — | — | 5,6,7 |
| | Avg = 1 | 9.5 | 9.7 | — | Bits | |
| | Avg = 2 | 9.9 | 10.1 | — | Bits | |
| | Avg = 16 | 10.8 | 11 | — | Bits | |
| SINAD | Signal to Noise plus Distortion | $SINAD = 6.02 \times ENOB + 1.76$ | | | dB | — |
| E _G | Gain error | — | 0.29 | — | %FSV | 8 |
| E _O | Offset error | — | 0.01 | — | %FSV | 9 |
| I _{VDDA18} | Supply Current | — | 480 | — | μA | 10 |
| I _{in,ext,leak} | External Channel Leakage Current | — | 30 | 500 | nA | — |
| E _{IL} | Input leakage error | $RAS \cdot I_{in}$ | | | mV | — |

¹ Typical values assume VDD_ANA_1P8 = 1.8 V, Temp = 25 °C, f_{ACLK} = Max, unless otherwise stated. Typical values are for reference only. All values, including Min and Max, are derived from lab characterization and are not tested in production.

² This resistance is external to the input pad. To achieve the best results, the analog source resistance must be kept as low as possible. The results in this data sheet were derived from a system that had < 15 Ω analog source resistance. The RAS/CAS (analog source capacitance) time constant should be kept to < 1 ns.

³ See Figure 57.

⁴ ADC conversion clock at max frequency and using linear histogram.

⁵ Input data used for test was 1 kHz sine wave.

⁶ Measured at VREFH = 1 V and pwrsel = 2.

⁷ ENOB can be lower than shown, if an ADC channel corrupts other ADC channels through capacitive coupling. This coupling may be dominated by board parasitics. Care must be taken not to corrupt the desired channel being measured. This coupling becomes worse at higher analog frequencies and with switching waveforms due to the harmonic content.

⁸ Error measured at fullscale at 1.0 V.

⁹ Error measured at zero scale at 0 V.

¹⁰ Power Configuration Select, PWRSEL, is set to 10 binary.

The following figure shows a plot of the ADC sample time versus R_{AS} .

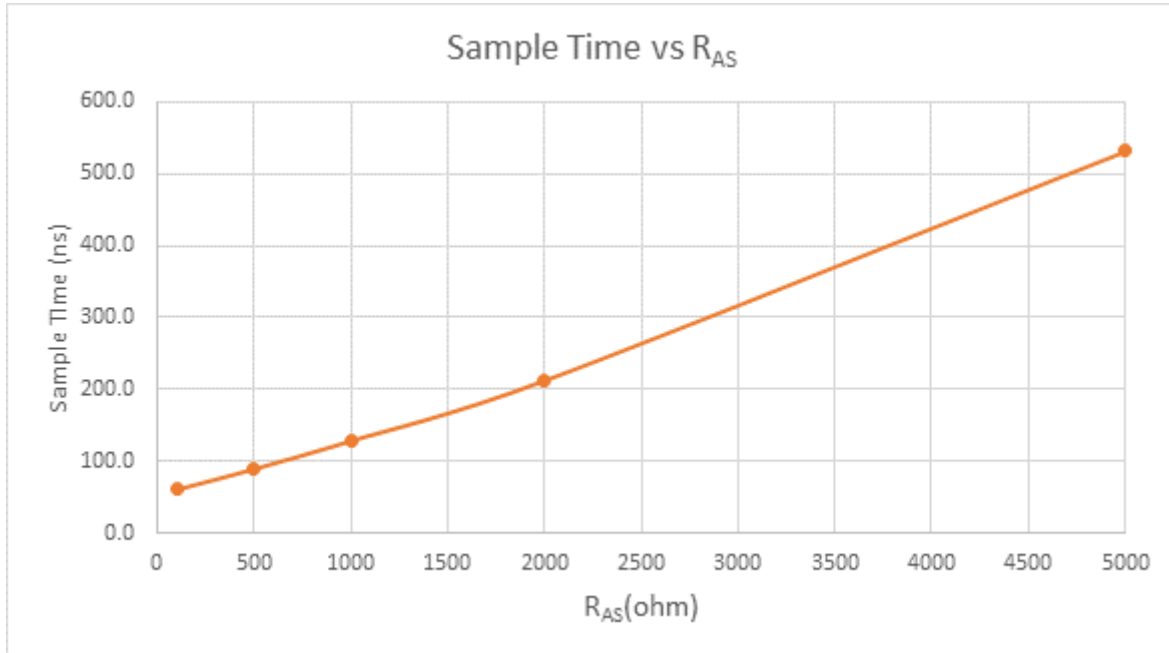

Figure 57. Sample time vs. R_{AS}

5 Boot mode configuration

This section provides information on boot mode configuration pins allocation and boot devices interfaces allocation.

5.1 Boot mode configuration pins

The following table provides boot options, functionality, fuse values, and associated pins. Several input pins are also sampled at reset and can be used to override fuse values, depending on the value of FORCE_BOOT_FROM_FUSE. After it is blown, the Boot mode pin is ignored by ROM; ROM receives 'boot mode' from the BT_MODE_FUSES fuse. The boot option pins are in effect when BT_FUSE_SEL fuse is '0' (cleared, which is the case for an unblown fuse). For detailed boot mode options configured by the Boot mode pins, see the “System Boot, Fusemap, and eFuse” chapter of the device reference manual for more details.

Table 122. Fuse and associated pins used for Boot

| Interface | IP Instance | Allocated Pads During Boot | Comment |
|--------------|-------------|----------------------------|---------------------|
| BOOT_MODE[0] | Input | SCU_BOOT_MODE0 | Boot mode selection |
| BOOT_MODE[1] | Input | SCU_BOOT_MODE1 | |
| BOOT_MODE[2] | Input | SCU_BOOT_MODE2 | |
| BOOT_MODE[3] | Input | SCU_BOOT_MODE3 | |

5.2 Boot devices interfaces allocation

The following table lists the interfaces that can be used by the boot process in accordance with the specific Boot mode configuration. The table also describes the interface’s specific modes and IOMUXC allocation, which are configured during boot when appropriate.

Table 123. Interface allocation during boot

| Interface | IP Instance | Allocated Pads During Boot | Comment |
|-----------|-------------|---|---|
| eMMC | USDHC0 | EMMC0_CLK, EMMC0_CMD, EMMC0_DATA0, EMMC0_DATA1, EMMC0_DATA2, EMMC0_DATA3, EMMC0_DATA4, EMMC0_DATA5, EMMC0_DATA6, EMMC0_DATA7, EMMC0_RESET_B | |
| SD | USDHC1 | USDHC1_CD_B, USDHC1_CLK, USDHC1_CMD, USDHC1_DATA0, USDHC1_DATA1, USDHC1_DATA2, USDHC1_DATA3, USDHC1_RESET_B, USDHC1_VSELECT | USDHC1_CD_B is used by first (A0) silicon only. Second (B0) silicon uses USDHC1_DATA3 for CD (Card Detect). |

Table 123. Interface allocation during boot (continued)

| Interface | IP Instance | Allocated Pads During Boot | Comment |
|-----------|-------------|---|--|
| NAND | GPMI | EMMC0_CLK, EMMC0_CMD, EMMC0_DATA0, EMMC0_DATA1, EMMC0_DATA2, EMMC0_DATA3, EMMC0_DATA4, EMMC0_DATA5, EMMC0_DATA6, EMMC0_DATA7, EMMC0_STROBE, EMMC0_RESET_B, USDHC1_CD_B, USDHC1_CMD, USDHC1_DATA0, USDHC1_DATA1, USDHC1_DATA2, USDHC1_DATA3, USDHC1_RESET_B, USDHC1_VSELECT, USDHC1_WP | 8 bit boot from CS0 only, but will drive CS1 to high when booting if specified in fuse. Single-ended DQS: • USDHC1_CD_B Single-ended RE: • USDHC1_VSELECT Differential DQS: • _N use USDHC1_WP • _P use USDHC1_CD_B Differential RE: • _N use USDHC1_RESET_B • _P use USDHC1_VSELECT |
| Quad SPI | QSPIO | QSPIOA_DATA0, QSPIOA_DATA1, QSPIOA_DATA2, QSPIOA_DATA3, QSPIOA_DQS, QSPIOA_SCLK, QSPIOA_SS0_B, QSPIOA_SS1_B, QSPIOB_DATA0, QSPIOB_DATA1, QSPIOB_DATA2, QSPIOB_DATA3, QSPIOB_DQS, QSPIOB_SCLK, QSPIOB_SS0_B, QSPIOB_SS1_B | 4, dual-4, or 8 bit |
| USB | USB-OTG1 | USB_OTG1_DN, USB_OTG2_DN, USB_OTG1_DP, USB_OTG2_DP, USB_OTG1_ID, USB_OTG2_ID, USB_OTG1_VBUS, USB_OTG2_VBUS | |

6 Package information and contact assignments

This section contains package information and contact assignments for the following package(s):

- [FCPBGA, 21 x 21 mm, 0.8 mm pitch](#)
- [FCPBGA, 17 x 17 mm, 0.8 mm pitch](#)

6.1 FCPBGA, 21 x 21 mm, 0.8 mm pitch

This section includes the following information for the 21 x 21 mm, 0.8 mm pitch package:

- Mechanical package drawing
- Ball map
- Contact assignments

Package information and contact assignments

The following notes pertain to the preceding figure, “21 x 21 mm Package Top, Bottom, and Side Views.”

NOTES:





1. ALL DIMENSIONS IN MILLIMETERS.
2. DIMENSIONING AND TOLERANCING PER ASME Y14.5M–1994.
-  3. MAXIMUM SOLDER BALL DIAMETER MEASURED PARALLEL TO DATUM C.
-  4. DATUM C, THE SEATING PLANE, IS DETERMINED BY THE SPHERICAL CROWNS OF THE SOLDER BALLS.
-  5. PARALLELISM MEASUREMENT SHALL EXCLUDE ANY EFFECT OF MARK ON TOP SURFACE OF PACKAGE.
6. ALL DIMENSIONS ARE SYMMETRIC ACROSS THE PACKAGE CENTER LINES, UNLESS DIMENSIONED OTHERWISE.
-  7. PIN 1 THRU HOLE SHALL BE CENTERED WITHIN FOOT AREA.
8. LID OVERHANG ON SUBSTRATE NOT ALLOWED.

Figure 59. Notes on 21 x 21 mm Package Top, Bottom, and Side Views

6.1.2 21 x 21 mm, 0.8 mm pitch ball map

The following page shows the 21 x 21 mm, 0.8 mm pitch ball map.

Package information and functional contact assignments for FCPBGA, 21 x 21 mm, 0.8 mm pitch

| | 1 | 2 | 3 | 4 | 5 | 6 | 7 | 8 | 9 | 10 | 11 | 12 | 13 | 14 | 15 | 16 | 17 | 18 | 19 | 20 | 21 | 22 | 23 | 24 | 25 | 26 | 27 | 28 | 29 | 30 | 31 | 32 | 33 | 34 | 35 | | | | |
|----|-------------|-------------|-------------|-------------|-------------|-------------|---------------|--------------|---------------|------------------------|----------------------------|----------------------|------------------------|-------------------|---------------------|--------------------|--------------------|------------------------------|--------------------|---------------------|-------------------------------|------------------------|------------------------|--------------------|------------------------|------------------------|-----------------------------|-------------------------|----------------------------|---------------------|---------------------|----------------------|----------------------|---------------------|---------------------|--------------------|---------------------|--------------|-----------|
| A | | | VSS_MAI_N | | DDR_DQ_31 | | DDR_DQ_28 | | PCIE0_T_X0_N | | PCIE0_CT_RLO_WA KE_B | | PCIE0_R_X0_P | | USB_SS3_TX_N | | VSS_MAI_N | | USB_SS3_RX_P | | EMMC0_DATA1 | | EMMC0_DATA6 | | USDHC1_VSELECT | | USDHC1_DATA0 | | ENETO_R_GMII_TX_CTL | | ENETO_R_GMII_RX_D0 | | VSS_MAI_N | | | | | | |
| B | | DDR_DQ_30 | | DDR_DQ_29 | | DDR_DQ1_6 | | VSS_MAI_N | | PCIE0_T_X0_P | | PCIE0_R_X0_N | | VSS_MAI_N | | USB_SS3_TX_P | | USB_SS3_RX_N | | VSS_MAI_N | | EMMC0_DATA4 | | USDHC1_RESET_B | | USDHC1_DATA1 | | ENETO_R_GMII_TX_D1 | | ENETO_R_GMII_RX_CTL | | ENETO_MDDIO | | ESAI0_T_X1 | | | | | |
| C | VSS_MAI_N | | VSS_MAI_N | | VSS_MAI_N | | VSS_MAI_N | | VSS_MAI_N | | VSS_MAI_N | | VSS_MAI_N | | USB_SS3_TC3 | | VSS_MAI_N | | VSS_MAI_N | | EMMC0_DATA0 | | VSS_MAI_N | | USDHC1_CMD | | VSS_MAI_N | | ENETO_R_GMII_TX_D1 | | VSS_MAI_N | | ESAI0_T_X3_RX2 | | VSS_MAI_N | | | | |
| D | | DDR_DQ_S3_P | | DDR_DM_2 | | DDR_DQ_S2_P | | DDR_DQ1_9 | | PCIE0_CT_RLO_CLK REQ_B | | PCIE0_RE_FCLK100_M_N | | USB_OT_G2_REXT | | USB_OT_G2_DN | | USB_OT_G1_DP | | EMMC0_CMD | | EMMC0_DATA7 | | USDHC1_WP | | USDHC1_DATA2 | | ENETO_R_GMII_RX_C | | ENETO_MDC | | ESAI0_T_X0 | | SPDIF0_T_X | | | | | |
| E | DDR_DM_3 | | DDR_DQ_S3_N | | DDR_DQ_S2_N | | DDR_DQ1_8 | | DDR_DQ1_7 | | PCIE0_RE_FCLK100_M_P | | USB_SS3_REXT | | VSS_MAI_N | | USB_OT_G2_DP | | USB_OT_G1_DN | | EMMC0_DATA2 | | USDHC1_CD_B | | USDHC1_DATA3 | | ENETO_R_GMII_TX_D2 | | VSS_MAI_N | | ESAI0_S_CKT | | VSS_MAI_N | | SPDIF0_E_XT_CLK | | | | |
| F | | VSS_MAI_N | | VSS_MAI_N | | VSS_MAI_N | | VSS_MAI_N | | VSS_MAI_N | | PCIE0_RE_F_QR | | USB_SS3_TC0 | | USB_OT_G2_ID | | VSS_MAI_N | | VSS_MAI_N | | EMMC0_STROBE | | VSS_MAI_N | | ENETO_R_GMII_TX_D3 | | ENETO_R_EFCLK_12_5M_25M | | ESAI0_FS_R | | ESAI0_T_X4_RX1 | | SPI3_SD_O | | | | | |
| G | DDR_DQ_27 | | DDR_DQ_26 | | DDR_DQ_23 | | DDR_DQ_20 | | DDR_ZQ | | PCIE0_PHY_PLL_R EF_RETU RN | | VDD_PCI_E_1P8 | | USB_SS3_TC2 | | USB_OT_G1_ID | | EMMC0_CLK | | EMMC0_DATA5 | | USDHC1_CLK | | ENETO_R_GMII_TX_D0 | | ENETO_R_GMII_RX_D2 | | ESAI0_FS_T | | SPDIF0_RX | | SPI3_SDI | | MCLK_IN_0 | | | | |
| H | | DDR_DQ_24 | | DDR_DQ_25 | | DDR_DQ_22 | | DDR_DQ_21 | | PCIE0_CT_RLO_PER ST_B | | PCIE0_RE_XT | | USB_SS3_TC1 | | USB_OT_G2_VBUS | | USB_OT_G1_VBUS | | EMMC0_DATA3 | | EMMC0_RESET_B | | ENETO_R_GMII_TX_C | | ENETO_R_GMII_RX_D3 | | ESAI0_S_CKR | | VSS_MAI_N | | SPI3_SCK | | UART1_T_X | | | | | |
| J | VSS_MAI_N | | VSS_MAI_N | | VSS_MAI_N | | VSS_MAI_N | | VSS_MAI_N | | VSS_MAI_N | | VSS_MAI_N | | VSS_MAI_N | | VSS_MAI_N | | VSS_MAI_N | | VSS_MAI_N | | VSS_MAI_N | | VSS_MAI_N | | VSS_MAI_N | | ESAI0_T_X5_RX0 | | SPI3_CS0 | | VSS_MAI_N | | SAI0_TX_C | | | | |
| K | | DDR_DC_F29 | | DDR_DC_F27 | | DDR_DC_F28 | | DDR_DC_F25 | | VSS_MAI_N | | VSS_MAI_N | | VSS_MAI_N | | VSS_MAI_N | | VSS_MAI_N | | VSS_MAI_N | | VSS_MAI_N | | VSS_MAI_N | | VSS_MAI_N | | VSS_MAI_N | | ESAI0_T_X2_RX3 | | SPI3_CS1 | | UART1_C_TS_B | | SAI0_TX_D | | | |
| L | DDR_DC_F18 | | DDR_DC_F32 | | DDR_DC_F31 | | DDR_DC_F26 | | VSS_MAI_N | | VDD_PCI_E_DIG_1P_8_3P3 | | VDD_PCI_E_LDO_1_P0_CAP | | VDD_US_B_3P3 | | VDD_US_B_OTG_1_P0 | | VDD_EM_MCO_1P8_3P3 | | VDD_US_DNCL_VS ELECT_1P_8_3P3 | | VDD_EN_ET_MDIO_1P8_3P3 | | VDD_EN_ETD_1P8_2P5_3P3 | | VSS_MAI_N | | MCLK_0_UTO | | UART1_R_X | | SAI0_TX_FS | | SAI1_RX_C | | | | |
| M | | VSS_MAI_N | | VSS_MAI_N | | VSS_MAI_N | | VSS_MAI_N | | VSS_MAI_N | | VDD_DD_R_VDDQ | | VDD_AN_A0_1P8 | | VDD_US_B_1P8 | | VDD_EM_MCO_VS ELECT_1P_8_3P3 | | VDD_US_DNCL_1P8_3P3 | | VDD_EN_ETD_1P8_2P5_3P3 | | VSS_MAI_N | | MCLK_IN_1 | | VSS_MAI_N | | SAI1_RX_D | | SAI0_RX_D | | SAI0_RX_D | | | | | |
| N | DDR_DC_F19 | | DDR_DC_F17 | | DDR_CK1_N | | DDR_DC_F30 | | VDD_DD_R_VDDQ | | VDD_DD_R_VDDQ | | VSS_MAI_N | | VDD_MA_IN | | VSS_MAI_N | | VDD_MA_IN | | VSS_MAI_N | | VDD_MA_IN | | VDD_GP_U | | VDD_ES_AI_SPDIF_1P8_2P5_3P3 | | VSS_MAI_N | | UART1_R_TS_B | | SPI2_SDI | | VSS_MAI_N | | SAI1_RX_F_5 | | |
| P | | DDR_DC_F22 | | DDR_DC_F20 | | DDR_CK1_P | | DDR_DC_F33 | | VSS_MAI_N | | VDD_MA_IN | | VSS_MAI_N | | VDD_MA_IN | | VSS_MAI_N | | VDD_MA_IN | | VSS_MAI_N | | VDD_GP_U | | VDD_GP_U | | VDD_MA_IN | | SPI2_CS0 | | SPI0_SCK | | SPI2_SD_O | | SPI0_SDI | | | |
| R | VSS_MAI_N | | VSS_MAI_N | | VSS_MAI_N | | VDD_DD_R_VDDQ | | VSS_MAI_N | | VDD_DD_R_VDDQ | | VDD_MA_IN | | VSS_MAI_N | | VDD_MA_IN | | VSS_MAI_N | | VDD_MA_IN | | VSS_MAI_N | | VDD_GP_U | | VSS_MAI_N | | VDD_SPI_MCLK_UART_1P_8_3P3 | | VSS_MAI_N | | SPI2_SCK | | SPI0_SD_O | | SPI0_CS0 | | SPI0_CS1 |
| T | | DDR_DC_F07 | | DDR_DC_F23 | | DDR_DC_F24 | | DDR_DC_F21 | | VSS_MAI_N | | VDD_DD_R_VDDQ | | VDD_MA_IN | | VSS_MAI_N | | VDD_MA_IN | | VSS_MAI_N | | VDD_MA_IN | | VSS_MAI_N | | VDD_GP_U | | VSS_MAI_N | | VSS_MAI_N | | VSS_MAI_N | | VSS_MAI_N | | VSS_MAI_N | | VSS_MAI_N | |
| U | DDR_DC_F03 | | DDR_DC_F01 | | DDR_DC_F05 | | DDR_DC_F04 | | VSS_MAI_N | | VDD_DD_R_VDDQ | | VSS_MAI_N | | VDD_MA_IN | | VSS_MAI_N | | VDD_MA_IN | | VSS_MAI_N | | VDD_MA_IN | | VDD_GP_U | | VDD_SAI_1P8_3P3 | | VSS_MAI_N | | ADC_VR_EFH | | ADC_VR_EFL | | ADC_IN1 | | ADC_IN0 | | |
| V | | VSS_MAI_N | | VSS_MAI_N | | VSS_MAI_N | | VSS_MAI_N | | VSS_MAI_N | | VDD_MA_IN | | VSS_MAI_N | | VDD_MA_IN | | VSS_MAI_N | | VDD_MA_IN | | VSS_MAI_N | | VDD_GP_U | | VSS_MAI_N | | VDD_MA_IN | | VSS_MAI_N | | VDD_AD_C_1P8 | | ADC_IN3 | | ADC_IN2 | | ADC_IN5 | |
| W | DDR_DC_F00 | | DDR_DC_F11 | | DDR_CK_0_P | | DDR_DC_F16 | | VSS_MAI_N | | VDD_DD_R_VDDQ | | VDD_MA_IN | | VSS_MAI_N | | VDD_MA_IN | | VSS_MAI_N | | VDD_MA_IN | | VSS_MAI_N | | VDD_GP_U | | VSS_MAI_N | | VDD_AD_C_DIG_1P_8 | | VSS_MAI_N | | ADC_IN4 | | VSS_MAI_N | | VSS_MAI_N | | VSS_MAI_N |
| Y | | DDR_DC_F14 | | DDR_DC_F15 | | DDR_CK_0_N | | DDR_DC_F12 | | VSS_MAI_N | | VDD_DD_R_VDDQ | | VDD_MA_IN | | VSS_MAI_N | | VDD_MA_IN | | VSS_MAI_N | | VDD_MA_IN | | VSS_MAI_N | | VDD_MA_IN | | VDD_CA_N_UART_1P8_3P3 | | VSS_MAI_N | | VSS_MAI_N | | VSS_MAI_N | | FLEXCAN_0_TX | | FLEXCAN_0_RX | |
| AA | VSS_MAI_N | | VSS_MAI_N | | VSS_MAI_N | | VSS_MAI_N | | VDD_DD_R_VDDQ | | VDD_DD_R_VDDQ | | VSS_MAI_N | | VDD_A35 | | VDD_A35 | | VDD_A35 | | VSS_MAI_N | | VDD_MA_IN | | VDD_MA_IN | | VDD_MIP_1_DS1_DI_G_1P8_3P3 | | VSS_MAI_N | | UART0_T_X | | FLEXCAN_2_TX | | FLEXCAN_1_RX | | FLEXCAN_1_TX | | |
| AB | | DDR_DQ1_4 | | DDR_DC_F08 | | DDR_DC_F09 | | DDR_AT_0 | | VSS_MAI_N | | VDD_MA_IN | | VSS_MAI_N | | VDD_A35 | | VDD_A35 | | VDD_A35 | | VSS_MAI_N | | VDD_AN_A1_1P8 | | VSS_MAI_N | | MIPI_DS1_0_I2CO_5_DA | | VSS_MAI_N | | MIPI_DS1_0_I2CO_5_DA | | UART0_RX | | FLEXCAN_2_RX | | | |
| AC | DDR_DQ1_5 | | DDR_DQ1_2 | | DDR_DC_F10 | | DDR_DT_00 | | VDD_DD_R_VDDQ | | VDD_DD_R_VDDQ | | VDD_MA_IN | | VSS_MAI_N | | VDD_MA_IN | | VSS_MAI_N | | VDD_MA_IN | | VSS_MAI_N | | VDD_MA_IN | | VDD_SN_VS_4P2 | | VSS_MAI_N | | MIPI_DS11_I2CO_5_DA | | MIPI_DS1_0_I2CO_5_CL | | VSS_MAI_N | | UART2_T_X | | |
| AD | | VSS_MAI_N | | VSS_MAI_N | | VSS_MAI_N | | DDR_VR_EF | | VSS_MAI_N | | VDD_DD_R_VDDQ | | VDD_MA_IN | | VDD_MIP_1_1P8 | | VDD_MIP_1_1P8 | | VSS_MAI_N | | VDD_MA_IN | | VDD_MA_IN | | VDD_TM_PR_CSI_1_P8_3P3 | | VSS_MAI_N | | SCU_WD_OG_OUT | | MIPI_DS11_GPI00_00 | | MIPI_DS1_0_GPI00_00 | | UART2_RX | | | |
| AE | DDR_DQ_S1_N | | DDR_DQ1_3 | | DDR_DQ_01 | | DDR_DT_01 | | VSS_MAI_N | | VDD_DD_R_VDDQ | | VDD_DS_P10B_1P8_3P3 | | VDD_DS_P10B_1P8_3P3 | | VDD_MIP_1_1P8 | | VDD_MIP_1_1P8 | | VSS_MAI_N | | VDD_MA_IN | | VDD_MA_IN | | VDD_CN_VS_LDO_1P8_CAP | | VSS_MAI_N | | TEST_H_ODE_SELECT | | JTAG_TCK | | MIPI_DS11_I2CO_5_CL | | MIPI_DS1_0_GPI00_01 | | |
| AF | | DDR_DQ_S1_P | | DDR_DM_1 | | DDR_DQ_00 | | DDR_DQ_03 | | VSS_MAI_N | | VSS_MAI_N | | VSS_MAI_N | | VSS_MAI_N | | VSS_MAI_N | | VSS_MAI_N | | VSS_MAI_N | | VSS_MAI_N | | VSS_MAI_N | | VSS_MAI_N | | SCU_GPI_00_00 | | VSS_MAI_N | | JTAG_TDO | | MIPI_DS11_GPI00_01 | | | |
| AG | VSS_MAI_N | | VSS_MAI_N | | VSS_MAI_N | | VSS_MAI_N | | VSS_MAI_N | | VSS_MAI_N | | VSS_MAI_N | | VSS_MAI_N | | VSS_MAI_N | | VSS_MAI_N | | VSS_MAI_N | | VSS_MAI_N | | VSS_MAI_N | | VSS_MAI_N | | SCU_PMI_C_STAN_DBY | | POR_B | | VSS_MAI_N | | VSS_MAI_N | | JTAG_TMS | | |
| AH | | DDR_DQ1_0 | | DDR_DQ1_1 | | DDR_DQ_S0_N | | DDR_DQ_02 | | QSPI0B_SS0_B | | QSPI0A_DATA3 | | VSS_MAI_N | | VSS_MAI_N | | VSS_MAI_N | | VSS_MAI_N | | VSS_MAI_N | | VSS_MAI_N | | VSS_MAI_N | | VSS_MAI_N | | ON_OFF_BUTTON | | SCU_GPI_00_01 | | PMIC_I2C_SDA | | JTAG_TDI | | | |
| AJ | DDR_DQ_08 | | DDR_DQ_09 | | DDR_DQ_S0_P | | DDR_DM_0 | | QSPI0B_SS1_B | | QSPI0B_DATA2 | | QSPI0A_DATA2 | | MIPI_DS1_0_DATA3_N | | MIPI_DS1_0_DATA1_N | | MIPI_DS1_0_DATA1_N | | MIPI_DS1_0_DATA0_N | | MIPI_DS1_0_DATA2_N | | MIPI_DS1_0_DATA2_N | | CSI_D06 | | CSI_D03 | | SCU_BO_OT_MODE3 | | SCU_BO_OT_MODE0 | | PMIC_IN_TB | | PMIC_I2C_SCL | | |
| AK | | VSS_MAI_N | | VSS_MAI_N | | VSS_MAI_N | | VSS_MAI_N | | QSPI0B_DQS | | QSPI0A_SS1_B | | QSPI0A_DATA0 | | MIPI_DS1_0_DATA3_P | | MIPI_DS1_0_DATA1_P | | MIPI_DS1_0_CLK_P | | MIPI_DS1_0_DATA2_P | | MIPI_DS1_0_DATA2_P | | CSI_PCLK | | CSI_D00 | | VSS_MAI_N | | SCU_BO_OT_MODE1 | | ANA_TES_T_OUT_N | | ANA_TES_T_OUT_P | | | |
| AL | DDR_DQ_32 | | DDR_DQ_34 | | DDR_DQ_06 | | DDR_DQ_07 | | QSPI0B_DATA1 | | QSPI0A_DQS | | VSS_MAI_N | | VSS_MAI_N | | VSS_MAI_N | | VSS_MAI_N | | VSS_MAI_N | | VSS_MAI_N | | VSS_MAI_N | | VSS_MAI_N | | CSI_VSYNC | | CSI_D01 | | SCU_BO_OT_MODE2 | | VSS_MAI_N | | ANA_TES_T_OUT_P | | |
| AM | | DDR_DQ_33 | | DDR_DQ_04 | | DDR_DQ_05 | | QSPI0B_DATA3 | | QSPI0B_DATA0 | | QSPI0A_SS0_B | | MIPI_DS11_DATA2_N | | MIPI_DS11_CLK_N | | MIPI_DS11_DATA3_N | | MIPI_CSI_0_DATA1_N | | MIPI_CSI_0_DATA0_N | | MIPI_CSI_0_DATA2_N | | MIPI_CSI_0_I2CO_5_DA | | CSI_MCLK | | CSI_D07 | | CSI_D05 | | RTC_XTALO | | XTALO | | | |
| AN | VSS_MAI_N | | VSS_MAI_N | | VSS_MAI_N | | VSS_MAI_N | | VSS_MAI_N | | VSS_MAI_N | | VSS_MAI_N | | MIPI_DS11_DATA0_N | | MIPI_DS11_DATA1_N | | MIPI_CSI_0_DATA3_N | | MIPI_CSI_0_DATA0_N | | MIPI_CSI_0_DATA2_N | | MIPI_CSI_0_MCLK_OUT | | VSS_MAI_N | | CSI_D04 | | VSS_MAI_N | | VSS_SCU_XTAL | | VSS_SCU_XTAL | | | | |
| AP | | DDR_DQ_35 | | DDR_DQ_S4_P | | DDR_DM_4 | | DDR_DQ_36 | | DDR_DQ_37 | | QSPI0A_SCLK | | MIPI_DS11_DATA2_P | | MIPI_DS11_CLK_P | | MIPI_DS11_DATA3_P | | MIPI_CSI_0_DATA1_P | | MIPI_CSI_0_DATA0_P | | MIPI_CSI_0_DATA2_P | | MIPI_CSI_0_GPI00_01 | | MIPI_CSI_0_I2CO_5_CL | | CSI_EN | | CSI_D02 | | RTC_XTALI | | XTALI | | | |
| AR | | | VSS_MAI_N | | DDR_DQ_S4_N | | DDR_DQ_39 | | DDR_DQ_38 | | QSPI0B_SCLK | | QSPI0A_DATA1 | | MIPI_DS11_DATA0_P | | MIPI_DS11_DATA1_P | | MIPI_CSI_0_DATA3_P | | MIPI_CSI_0_CLK_P | | MIPI_CSI_0_DATA2_P | | MIPI_CSI_0_GPI00_00 | | CSI_RES ET | | CSI_HSYNC | | PMIC_ON_REQ | | VSS_SCU_XTAL | | | | | | |

i.MX8QuadXPlus/8DualXPlusAutomotiveandInfotainmentApplicationsProcessors,Rev.3,05/2020

6.1.3 21 x 21 mm power supplies and functional contact assignments

The following table shows the power supplies contact assignments for the 21 × 21 mm package

Table 124. 21 x 21 mm power supplies contact assignments

| Power rail | Ball reference |
|-------------------------------|--|
| VDD_A35 ¹ | AA15,AA17,AA19,AB16,AB18,AB20 |
| VDD_ADC_1P8 | V28 |
| VDD_ADC_DIG_1P8 | W25 |
| VDD_ANA0_1P8 | M14 |
| VDD_ANA1_1P8 | AB24 |
| VDD_CAN_UART_1P8_3P3 | Y24 |
| VDD_CSI_1P8_3P3 | AE23 |
| VDD_DDR_PLL_1P8 | AC9 |
| VDD_DDR_VDDQ | AA11,AA9,M12,N9,N11,R7,R11,T12,U11,W11,Y12,AC11,AD12,AE11 |
| VDD_EMMC0_1P8_3P3 | L19 |
| VDD_EMMC0_VSELECT_1P8_3P3 | M20 |
| VDD_ENET_MDIO_1P8_3P3 | L25 |
| VDD_ENET0_1P8_2P5_3P3 | M24 |
| VDD_ENET0_VSELECT_1P8_2P5_3P3 | L23 |
| VDD_ESAI_SPDIF_1P8_2P5_3P3 | N25 |
| VDD_GPU ¹ | N23,P20,P22,R21,T22,U23,V20,W21 |
| VDD_MAIN | AA23,AB12,AC13,AC17,AC21,AD14,AD22,N15,N19,P12,P16,P24,R13,R17,T14,T18,U15,U19,V12,V16,V24,W13,W17,Y14,Y18,Y22 |
| VDD_MIPI_1P0 | AD18,AE19 |
| VDD_MIPI_1P8 | AD16,AE17 |
| VDD_MIPI_CSI_DIG_1P8 | AE21 |
| VDD_MIPI_DSI_DIG_1P8_3P3 | AA25 |
| VDD_PCIE_1P8 | G13 |
| VDD_PCIE_DIG_1P8_3P3 | L11 |
| VDD_PCIE_LDO_1P0_CAP | L13 |
| VDD_QSPI0A_1P8_3P3 | AE15 |
| VDD_QSPI0B_1P8_3P3 | AE13 |
| VDD_SNVS_4P2 | AC25 |
| VDD_SNVS_LDO_1P8_CAP | AE25 |
| VDD_SPI_MCLK_UART_1P8_3P3 | R25 |

Table 124. 21 x 21 mm power supplies contact assignments (continued)

| Power rail | Ball reference |
|----------------------------|--|
| VDD_SPI_SAI_1P8_3P3 | U25 |
| VDD_TMPR_CSI_1P8_3P3 | AD24 |
| VDD_USB_1P8 | M18 |
| VDD_USB_3P3 | L15 |
| VDD_USB_OTG_1P0 | L17 |
| VDD_USB_SS3_LDO_1P0_CAP | M16 |
| VDD_USDHC1_1P8_3P3 | M22 |
| VDD_USDHC1_VSELECT_1P8_3P3 | L21 |
| VSS_MAIN | A17, A3, A33, AA1, AA13, AA21, AA27, AA3, AA5, AA7, AB10, AB14, AB22, AB26, AB30, AC15, AC19, AC23, AC27, AC33, AD10, AD2, AD20, AD26, AD4, AD6, AE27, AE9, AF10, AF12, AF14, AF16, AF18, AF20, AF22, AF24, AF26, AF30, AG1, AG11, AG13, AG15, AG17, AG19, AG21, AG23, AG25, AG27, AG3, AG33, AG5, AG7, AG9, AH14, AH16, AH18, AH20, AH22, AH24, AH26, AK2, AK30, AK4, AK6, AK8, AL13, AL15, AL17, AL19, AL21, AL23, AL25, AL33, AN1, AN11, AN13, AN27, AN3, AN31, AN5, AN7, AN9, AR3, B14, B20, B8, C1, C11, C13, C17, C19, C23, C27, C3, C31, C35, C5, C7, C9, E15, E29, E33, F10, F18, F2, F20, F24, F4, F6, F8, H30, J1, J11, J13, J15, J17, J19, J21, J23, J25, J27, J3, J33, J5, J7, J9, K10, K12, K14, K16, K18, K20, K22, K24, K26, L27, L9, M10, M2, M26, M30, M4, M6, M8, N13, N17, N21, N27, N33, P10, P14, P18, P26, R1, R15, R19, R23, R27, R3, R5, R9, T10, T16, T20, T24, T26, T28, T30, T32, T34, U13, U17, U21, U27, U9, V10, V14, V18, V2, V22, V26, V4, V6, V8, W15, W19, W23, W27, W31, W33, W35, W9, Y10, Y16, Y20, Y26, Y28, Y30 |
| VSS_SCU_XTAL | AN33, AN35, AR33 |

¹ VDD_A35 and VDD_GPU can be combined with one power supply.

The following table shows functional contact assignments for the 21 × 21 mm package.

Table 125. 21 x 21 mm functional contact assignments

| Ball | Ball Name | Power Domain | Ball Type ₁ | Reset Condition ² | | | |
|------|----------------|---------------------------|------------------------|------------------------------|--------------------|-------------------|--------------|
| | | | | Default Mode | Default Function | Default Direction | Default Pull |
| U35 | ADC_IN0 | VDD_ADC_DIG_1P8 | GPIO | ALT0 | ADMA.ADC.IN0 | INPUT | PD(50K) |
| U33 | ADC_IN1 | VDD_ADC_DIG_1P8 | GPIO | ALT0 | ADMA.ADC.IN1 | INPUT | PD(50K) |
| V32 | ADC_IN2 | VDD_ADC_DIG_1P8 | GPIO | ALT0 | ADMA.ADC.IN2 | INPUT | PD(50K) |
| V30 | ADC_IN3 | VDD_ADC_DIG_1P8 | GPIO | ALT0 | ADMA.ADC.IN3 | INPUT | PD(50K) |
| W29 | ADC_IN4 | VDD_ADC_DIG_1P8 | GPIO | ALT0 | ADMA.ADC.IN4 | INPUT | PD(50K) |
| V34 | ADC_IN5 | VDD_ADC_DIG_1P8 | GPIO | ALT0 | ADMA.ADC.IN5 | INPUT | PD(50K) |
| U29 | ADC_VREFH | VDD_ADC_1P8 | ANA | | ADC_VREFH | | |
| U31 | ADC_VREFL | VDD_ADC_1P8 | ANA | | ADC_VREFL | | |
| AK34 | ANA_TEST_OUT_N | VDD_SCU_ANA_1P8 | ANA | | SCU.DSC.TEST_OUT_N | | |
| AL35 | ANA_TEST_OUT_P | VDD_SCU_ANA_1P8 | ANA | | SCU.DSC.TEST_OUT_P | | |
| AK28 | CSI_D00 | VDD_TMPR_CSI_1P8_3P3 | GPIO | ALT0 | CI_PI.CSI_D02 | INPUT | PD(50K) |
| AL29 | CSI_D01 | VDD_TMPR_CSI_1P8_3P3 | GPIO | ALT0 | CI_PI.CSI_D03 | INPUT | PD(50K) |
| AP30 | CSI_D02 | VDD_TMPR_CSI_1P8_3P3 | GPIO | ALT0 | CI_PI.CSI_D04 | INPUT | PD(50K) |
| AJ27 | CSI_D03 | VDD_TMPR_CSI_1P8_3P3 | GPIO | ALT0 | CI_PI.CSI_D05 | INPUT | PD(50K) |
| AN29 | CSI_D04 | VDD_TMPR_CSI_1P8_3P3 | GPIO | ALT0 | CI_PI.CSI_D06 | INPUT | PD(50K) |
| AM30 | CSI_D05 | VDD_TMPR_CSI_1P8_3P3 | GPIO | ALT0 | CI_PI.CSI_D07 | INPUT | PD(50K) |
| AJ25 | CSI_D06 | VDD_TMPR_CSI_1P8_3P3 | GPIO | ALT0 | CI_PI.CSI_D08 | INPUT | PD(50K) |
| AM28 | CSI_D07 | VDD_TMPR_CSI_1P8_3P3 | GPIO | ALT0 | CI_PI.CSI_D09 | INPUT | PD(50K) |
| AR29 | CSI_HSYNC | VDD_TMPR_CSI_1P8_3P3 | GPIO | ALT0 | CI_PI.CSI_HSYNC | INPUT | PD(50K) |
| AL27 | CSI_VSYNC | VDD_TMPR_CSI_1P8_3P3 | GPIO | ALT0 | CI_PI.CSI_VSYNC | INPUT | PD(50K) |
| AP28 | CSI_EN | VDD_CSI_1P8_3P3 | GPIO | ALT0 | CI_PI.CSI_EN | INPUT | PD(50K) |
| AM26 | CSI_MCLK | VDD_CSI_1P8_3P3 | GPIO | ALT4 | LSIO.GPIO3.IO01 | INPUT | PD(50K) |
| AK26 | CSI_PCLK | VDD_CSI_1P8_3P3 | GPIO | ALT0 | CI_PI.CSI_PCLK | INPUT | PD(50K) |
| AR27 | CSI_RESET | VDD_CSI_1P8_3P3 | GPIO | ALT0 | CI_PI.CSI_RESET | INPUT | PD(50K) |
| G19 | EMMC0_CLK | VDD_EMMC0_1P8_3P3 | FASTD | ALT4 | LSIO.GPIO4.IO07 | INPUT | PD(50K) |
| D20 | EMMC0_CMD | VDD_EMMC0_1P8_3P3 | FASTD | ALT0 | CONN.EMMC0.CMD | INPUT | PD(50K) |
| C21 | EMMC0_DATA0 | VDD_EMMC0_1P8_3P3 | FASTD | ALT0 | CONN.EMMC0.DATA0 | INPUT | PD(50K) |
| A21 | EMMC0_DATA1 | VDD_EMMC0_1P8_3P3 | FASTD | ALT0 | CONN.EMMC0.DATA1 | INPUT | PD(50K) |
| E21 | EMMC0_DATA2 | VDD_EMMC0_1P8_3P3 | FASTD | ALT0 | CONN.EMMC0.DATA2 | INPUT | PD(50K) |
| H20 | EMMC0_DATA3 | VDD_EMMC0_1P8_3P3 | FASTD | ALT0 | CONN.EMMC0.DATA3 | INPUT | PD(50K) |
| B22 | EMMC0_DATA4 | VDD_EMMC0_VSELECT_1P8_3P3 | FASTD | ALT0 | CONN.EMMC0.DATA4 | INPUT | PD(50K) |
| G21 | EMMC0_DATA5 | VDD_EMMC0_VSELECT_1P8_3P3 | FASTD | ALT0 | CONN.EMMC0.DATA5 | INPUT | PD(50K) |
| A23 | EMMC0_DATA6 | VDD_EMMC0_VSELECT_1P8_3P3 | FASTD | ALT0 | CONN.EMMC0.DATA6 | INPUT | PD(50K) |

Table 125. 21 x 21 mm functional contact assignments (continued)

| Ball | Ball Name | Power Domain | Ball Type ¹ | Reset Condition ² | | | |
|------|-----------------------|-------------------------------|------------------------|------------------------------|-------------------------|-------------------|--------------|
| | | | | Default Mode | Default Function | Default Direction | Default Pull |
| D22 | EMMC0_DATA7 | VDD_EMMC0_VSELECT_1P8_3P3 | FASTD | ALT0 | CONN.EMMC0.DATA7 | INPUT | PD(50K) |
| H22 | EMMC0_RESET_B | VDD_EMMC0_VSELECT_1P8_3P3 | GPIO | ALT4 | LSIO.GPIO4.IO18 | INPUT | PU(50K) |
| F22 | EMMC0_STROBE | VDD_EMMC0_VSELECT_1P8_3P3 | FASTD | ALT0 | CONN.EMMC0.STROBE | INPUT | PD(50K) |
| D30 | ENET0_MDC | VDD_ENET_MDIO_1P8_3P3 | GPIO | ALT4 | LSIO.GPIO5.IO11 | INPUT | PD(50K) |
| B32 | ENET0_MDIO | VDD_ENET_MDIO_1P8_3P3 | GPIO | ALT0 | CONN.ENET0.MDIO | INPUT | PU(50K) |
| F28 | ENET0_REFCLK_125M_25M | VDD_ENET_MDIO_1P8_3P3 | GPIO | ALT4 | LSIO.GPIO5.IO09 | INPUT | PD(50K) |
| B30 | ENET0_RGMII_RX_CTL | VDD_ENET0_1P8_2P5_3P3 | FASTD | ALT0 | CONN.ENET0.RGMII_RX_CTL | INPUT | PD(50K) |
| D28 | ENET0_RGMII_RXC | VDD_ENET0_1P8_2P5_3P3 | FASTD | ALT0 | CONN.ENET0.RGMII_RXC | INPUT | PD(50K) |
| A31 | ENET0_RGMII_RXD0 | VDD_ENET0_1P8_2P5_3P3 | FASTD | ALT0 | CONN.ENET0.RGMII_RXD0 | INPUT | PD(50K) |
| C29 | ENET0_RGMII_RXD1 | VDD_ENET0_1P8_2P5_3P3 | FASTD | ALT0 | CONN.ENET0.RGMII_RXD1 | INPUT | PD(50K) |
| G27 | ENET0_RGMII_RXD2 | VDD_ENET0_1P8_2P5_3P3 | FASTD | ALT0 | CONN.ENET0.RGMII_RXD2 | INPUT | PD(50K) |
| H26 | ENET0_RGMII_RXD3 | VDD_ENET0_1P8_2P5_3P3 | FASTD | ALT0 | CONN.ENET0.RGMII_RXD3 | INPUT | PD(50K) |
| A29 | ENET0_RGMII_TX_CTL | VDD_ENET0_VSELECT_1P8_2P5_3P3 | FASTD | ALT4 | LSIO.GPIO4.IO30 | INPUT | PD(50K) |
| H24 | ENET0_RGMII_TXC | VDD_ENET0_VSELECT_1P8_2P5_3P3 | FASTD | ALT4 | LSIO.GPIO4.IO29 | INPUT | PD(50K) |
| G25 | ENET0_RGMII_TXD0 | VDD_ENET0_VSELECT_1P8_2P5_3P3 | FASTD | ALT4 | LSIO.GPIO4.IO31 | INPUT | PD(50K) |
| B28 | ENET0_RGMII_TXD1 | VDD_ENET0_VSELECT_1P8_2P5_3P3 | FASTD | ALT4 | LSIO.GPIO5.IO00 | INPUT | PD(50K) |
| E27 | ENET0_RGMII_TXD2 | VDD_ENET0_VSELECT_1P8_2P5_3P3 | FASTD | ALT4 | LSIO.GPIO5.IO01 | INPUT | PD(50K) |
| F26 | ENET0_RGMII_TXD3 | VDD_ENET0_VSELECT_1P8_2P5_3P3 | FASTD | ALT4 | LSIO.GPIO5.IO02 | INPUT | PD(50K) |
| F30 | ESAI0_FSR | VDD_ESAI_SPDIF_1P8_2P5_3P3 | GPIO | ALT0 | ADMA.ESAI0.FSR | INPUT | PD(50K) |
| G29 | ESAI0_FST | VDD_ESAI_SPDIF_1P8_2P5_3P3 | GPIO | ALT0 | ADMA.ESAI0.FST | INPUT | PD(50K) |
| H28 | ESAI0_SCKR | VDD_ESAI_SPDIF_1P8_2P5_3P3 | GPIO | ALT0 | ADMA.ESAI0.SCKR | INPUT | PD(50K) |
| E31 | ESAI0_SCKT | VDD_ESAI_SPDIF_1P8_2P5_3P3 | GPIO | ALT0 | ADMA.ESAI0.SCKT | INPUT | PD(50K) |
| D32 | ESAI0_TX0 | VDD_ESAI_SPDIF_1P8_2P5_3P3 | GPIO | ALT0 | ADMA.ESAI0.TX0 | INPUT | PD(50K) |
| B34 | ESAI0_TX1 | VDD_ESAI_SPDIF_1P8_2P5_3P3 | GPIO | ALT0 | ADMA.ESAI0.TX1 | INPUT | PD(50K) |
| K28 | ESAI0_TX2_RX3 | VDD_ESAI_SPDIF_1P8_2P5_3P3 | GPIO | ALT0 | ADMA.ESAI0.TX2_RX3 | INPUT | PD(50K) |
| C33 | ESAI0_TX3_RX2 | VDD_ESAI_SPDIF_1P8_2P5_3P3 | GPIO | ALT0 | ADMA.ESAI0.TX3_RX2 | INPUT | PD(50K) |
| F32 | ESAI0_TX4_RX1 | VDD_ESAI_SPDIF_1P8_2P5_3P3 | GPIO | ALT0 | ADMA.ESAI0.TX4_RX1 | INPUT | PD(50K) |
| J29 | ESAI0_TX5_RX0 | VDD_ESAI_SPDIF_1P8_2P5_3P3 | GPIO | ALT0 | ADMA.ESAI0.TX5_RX0 | INPUT | PD(50K) |
| Y34 | FLEXCAN0_RX | VDD_CAN_UART_1P8_3P3 | GPIO | ALT0 | ADMA.FLEXCAN0.RX | INPUT | PD(50K) |
| Y32 | FLEXCAN0_TX | VDD_CAN_UART_1P8_3P3 | GPIO | ALT4 | LSIO.GPIO1.IO16 | INPUT | PD(50K) |
| AA33 | FLEXCAN1_RX | VDD_CAN_UART_1P8_3P3 | GPIO | ALT0 | ADMA.FLEXCAN1.RX | INPUT | PD(50K) |
| AA35 | FLEXCAN1_TX | VDD_CAN_UART_1P8_3P3 | GPIO | ALT4 | LSIO.GPIO1.IO18 | INPUT | PD(50K) |
| AB34 | FLEXCAN2_RX | VDD_CAN_UART_1P8_3P3 | GPIO | ALT0 | ADMA.FLEXCAN2.RX | INPUT | PD(50K) |
| AA31 | FLEXCAN2_TX | VDD_CAN_UART_1P8_3P3 | GPIO | ALT4 | LSIO.GPIO1.IO20 | INPUT | PD(50K) |
| AE31 | JTAG_TCK | VDD_ANA1_1P8 | TEST | ALT0 | SCU.JTAG.TCK | INPUT | PD(50K) |

Table 125. 21 x 21 mm functional contact assignments (continued)

| Ball | Ball Name | Power Domain | Ball Type ₁ | Reset Condition ² | | | |
|------|--------------------|---------------------------|------------------------|------------------------------|----------------------|-------------------|--------------|
| | | | | Default Mode | Default Function | Default Direction | Default Pull |
| AH34 | JTAG_TDI | VDD_ANA1_1P8 | TEST | ALT0 | SCU.JTAG.TDI | INPUT | PU(50K) |
| AF32 | JTAG_TDO | VDD_ANA1_1P8 | TEST | ALT0 | SCU.JTAG.TDO | OUTPUT | HiZ |
| AG35 | JTAG_TMS | VDD_ANA1_1P8 | TEST | ALT0 | SCU.JTAG.TMS | INPUT | PU(50K) |
| G35 | MCLK_IN0 | VDD_SPI_MCLK_UART_1P8_3P3 | GPIO | ALT0 | ADMA.ACM.MCLK_IN0 | INPUT | PD(50K) |
| M28 | MCLK_IN1 | VDD_SPI_MCLK_UART_1P8_3P3 | GPIO | ALT0 | ADMA.ACM.MCLK_IN1 | INPUT | PD(50K) |
| L29 | MCLK_OUT0 | VDD_SPI_MCLK_UART_1P8_3P3 | GPIO | ALT4 | LSIO.GPIO0.IO20 | INPUT | PD(50K) |
| AN21 | MIPI_CSI0_CLK_N | VDD_MIPI_1P8 | CSI | | MIPI_CSI0.CKN | | Hi-Z |
| AR21 | MIPI_CSI0_CLK_P | VDD_MIPI_1P8 | CSI | | MIPI_CSI0.CKP | | Hi-Z |
| AM22 | MIPI_CSI0_DATA0_N | VDD_MIPI_1P8 | CSI | | MIPI_CSI0.DN0 | | Hi-Z |
| AP22 | MIPI_CSI0_DATA0_P | VDD_MIPI_1P8 | CSI | | MIPI_CSI0.DP0 | | Hi-Z |
| AM20 | MIPI_CSI0_DATA1_N | VDD_MIPI_1P8 | CSI | | MIPI_CSI0.DN1 | | Hi-Z |
| AP20 | MIPI_CSI0_DATA1_P | VDD_MIPI_1P8 | CSI | | MIPI_CSI0.DP1 | | Hi-Z |
| AN23 | MIPI_CSI0_DATA2_N | VDD_MIPI_1P8 | CSI | | MIPI_CSI0.DN2 | | Hi-Z |
| AR23 | MIPI_CSI0_DATA2_P | VDD_MIPI_1P8 | CSI | | MIPI_CSI0.DP2 | | Hi-Z |
| AN19 | MIPI_CSI0_DATA3_N | VDD_MIPI_1P8 | CSI | | MIPI_CSI0.DN3 | | Hi-Z |
| AR19 | MIPI_CSI0_DATA3_P | VDD_MIPI_1P8 | CSI | | MIPI_CSI0.DP3 | | Hi-Z |
| AR25 | MIPI_CSI0_GPIO0_00 | VDD_MIPI_CSI_DIG_1P8 | GPIO | ALT0 | MIPI_CSI0.GPIO0.IO00 | INPUT | PD(50K) |
| AP24 | MIPI_CSI0_GPIO0_01 | VDD_MIPI_CSI_DIG_1P8 | GPIO | ALT0 | MIPI_CSI0.GPIO0.IO01 | INPUT | PD(50K) |
| AP26 | MIPI_CSI0_I2C0_SCL | VDD_MIPI_CSI_DIG_1P8 | GPIO | ALT0 | MIPI_CSI0.I2C0.SCL | INPUT | PU(50K) |
| AM24 | MIPI_CSI0_I2C0_SDA | VDD_MIPI_CSI_DIG_1P8 | GPIO | ALT0 | MIPI_CSI0.I2C0.SDA | INPUT | PU(50K) |
| AN25 | MIPI_CSI0_MCLK_OUT | VDD_MIPI_CSI_DIG_1P8 | GPIO | ALT4 | LSIO.GPIO3.IO04 | INPUT | PD(50K) |
| AJ19 | MIPI_DSI0_CLK_N | VDD_MIPI_1P8 | DSI | | MIPI_DSI0.CKN | | Hi-Z |
| AK20 | MIPI_DSI0_CLK_P | VDD_MIPI_1P8 | DSI | | MIPI_DSI0.CKP | | Hi-Z |
| AJ21 | MIPI_DSI0_DATA0_N | VDD_MIPI_1P8 | DSI | | MIPI_DSI0.DN0 | | Hi-Z |
| AK22 | MIPI_DSI0_DATA0_P | VDD_MIPI_1P8 | DSI | | MIPI_DSI0.DP0 | | Hi-Z |
| AJ17 | MIPI_DSI0_DATA1_N | VDD_MIPI_1P8 | DSI | | MIPI_DSI0.DN1 | | Hi-Z |
| AK18 | MIPI_DSI0_DATA1_P | VDD_MIPI_1P8 | DSI | | MIPI_DSI0.DP1 | | Hi-Z |
| AJ23 | MIPI_DSI0_DATA2_N | VDD_MIPI_1P8 | DSI | | MIPI_DSI0.DN2 | | Hi-Z |
| AK24 | MIPI_DSI0_DATA2_P | VDD_MIPI_1P8 | DSI | | MIPI_DSI0.DP2 | | Hi-Z |
| AJ15 | MIPI_DSI0_DATA3_N | VDD_MIPI_1P8 | DSI | | MIPI_DSI0.DN3 | | Hi-Z |
| AK16 | MIPI_DSI0_DATA3_P | VDD_MIPI_1P8 | DSI | | MIPI_DSI0.DP3 | | Hi-Z |
| AD32 | MIPI_DSI0_GPIO0_00 | VDD_MIPI_DSI_DIG_1P8_3P3 | GPIO | ALT0 | MIPI_DSI0.GPIO0.IO00 | INPUT | PD(50K) |
| AE35 | MIPI_DSI0_GPIO0_01 | VDD_MIPI_DSI_DIG_1P8_3P3 | GPIO | ALT0 | MIPI_DSI0.GPIO0.IO01 | INPUT | PD(50K) |
| AC31 | MIPI_DSI0_I2C0_SCL | VDD_MIPI_DSI_DIG_1P8_3P3 | GPIO | ALT0 | MIPI_DSI0.I2C0.SCL | INPUT | PU(50K) |
| AB28 | MIPI_DSI0_I2C0_SDA | VDD_MIPI_DSI_DIG_1P8_3P3 | GPIO | ALT0 | MIPI_DSI0.I2C0.SDA | INPUT | PU(50K) |

Table 125. 21 x 21 mm functional contact assignments (continued)

| Ball | Ball Name | Power Domain | Ball Type ₁ | Reset Condition ² | | | |
|------|--------------------------|--------------------------|------------------------|------------------------------|--------------------------------|-------------------|--------------|
| | | | | Default Mode | Default Function | Default Direction | Default Pull |
| AM16 | MIPI_DSI1_CLK_N | VDD_MIPI_1P8 | DSI | | MIPI_DSI1.CKN | | Hi-Z |
| AP16 | MIPI_DSI1_CLK_P | VDD_MIPI_1P8 | DSI | | MIPI_DSI1.CKP | | Hi-Z |
| AN15 | MIPI_DSI1_DATA0_N | VDD_MIPI_1P8 | DSI | | MIPI_DSI1.DN0 | | Hi-Z |
| AR15 | MIPI_DSI1_DATA0_P | VDD_MIPI_1P8 | DSI | | MIPI_DSI1.DP0 | | Hi-Z |
| AN17 | MIPI_DSI1_DATA1_N | VDD_MIPI_1P8 | DSI | | MIPI_DSI1.DN1 | | Hi-Z |
| AR17 | MIPI_DSI1_DATA1_P | VDD_MIPI_1P8 | DSI | | MIPI_DSI1.DP1 | | Hi-Z |
| AM14 | MIPI_DSI1_DATA2_N | VDD_MIPI_1P8 | DSI | | MIPI_DSI1.DN2 | | Hi-Z |
| AP14 | MIPI_DSI1_DATA2_P | VDD_MIPI_1P8 | DSI | | MIPI_DSI1.DP2 | | Hi-Z |
| AM18 | MIPI_DSI1_DATA3_N | VDD_MIPI_1P8 | DSI | | MIPI_DSI1.DN3 | | Hi-Z |
| AP18 | MIPI_DSI1_DATA3_P | VDD_MIPI_1P8 | DSI | | MIPI_DSI1.DP3 | | Hi-Z |
| AD30 | MIPI_DSI1_GPIO0_00 | VDD_MIPI_DSI_DIG_1P8_3P3 | GPIO | ALT0 | MIPI_DSI1.GPIO0.IO00 | INPUT | PD(50K) |
| AF34 | MIPI_DSI1_GPIO0_01 | VDD_MIPI_DSI_DIG_1P8_3P3 | GPIO | ALT0 | MIPI_DSI1.GPIO0.IO01 | INPUT | PD(50K) |
| AE33 | MIPI_DSI1_I2C0_SCL | VDD_MIPI_DSI_DIG_1P8_3P3 | GPIO | ALT0 | MIPI_DSI1.I2C0.SCL | INPUT | PU(50K) |
| AC29 | MIPI_DSI1_I2C0_SDA | VDD_MIPI_DSI_DIG_1P8_3P3 | GPIO | ALT0 | MIPI_DSI1.I2C0.SDA | INPUT | PU(50K) |
| AH28 | ON_OFF_BUTTON | VDD_SNVS_LDO_1P8_CAP | ANA | | SNVS.ON_OFF_BUTTON | | |
| D10 | PCIE_CTRL0_CLKREQ_B | VDD_PCIE_DIG_1P8_3P3 | GPIO | ALT0 | HSIO.PCIE0.CLKREQ_B | INPUT | PD(50K) |
| H10 | PCIE_CTRL0_PERST_B | VDD_PCIE_DIG_1P8_3P3 | GPIO | ALT0 | HSIO.PCIE0.PERST_B | INPUT | PD(50K) |
| A11 | PCIE_CTRL0_WAKE_B | VDD_PCIE_DIG_1P8_3P3 | GPIO | ALT0 | HSIO.PCIE0.WAKE_B | INPUT | PU(50K) |
| F12 | PCIE_REF_QR | VDD_PCIE_1P8 | PCIE | | HSIO.PCIE_I0B.REF_QR | | |
| D12 | PCIE_REFCLK100M_N | VDD_PCIE_1P8 | PCIE | | HSIO.PCIE_I0B.EXT_REFCLK100M_N | | |
| E11 | PCIE_REFCLK100M_P | VDD_PCIE_1P8 | PCIE | | HSIO.PCIE_I0B.EXT_REFCLK100M_P | | |
| H12 | PCIE_REXT | VDD_PCIE0_1P0 | PCIE | | HSIO.PCIE.REXT | | |
| G11 | PCIE0_PHY_PLL_REF_RETURN | VDD_PCIE_LDO_1P0_CAP | PCIE | | HSIO.PCIE0.PLL_REF_RETURN | | |
| B12 | PCIE0_RX0_N | VDD_PCIE_LDO_1P0_CAP | PCIE | | HSIO.PCIE0.RX0_N | | |
| A13 | PCIE0_RX0_P | VDD_PCIE_LDO_1P0_CAP | PCIE | | HSIO.PCIE0.RX0_P | | |
| A9 | PCIE0_TX0_N | VDD_PCIE_LDO_1P0_CAP | PCIE | | HSIO.PCIE0.TX0_N | | |
| B10 | PCIE0_TX0_P | VDD_PCIE_LDO_1P0_CAP | PCIE | | HSIO.PCIE0.TX0_P | | |
| AJ35 | PMIC_I2C_SCL | VDD_ANA1_1P8 | SCU | ALT0 | SCU.PMIC_I2C.SCL | INPUT | PU(50K) |
| AH32 | PMIC_I2C_SDA | VDD_ANA1_1P8 | SCU | ALT0 | SCU.PMIC_I2C.SDA | INPUT | PU(50K) |
| AJ33 | PMIC_INT_B | VDD_ANA1_1P8 | SCU | ALT0 | SCU.DSC.PMIC_INT_B | INPUT | PU(50K) |
| AR31 | PMIC_ON_REQ | VDD_SNVS_LDO_1P8_CAP | ANA | | SNVS.PMIC_ON_REQ | | |
| AG31 | POR_B | VDD_ANA1_1P8 | SCU | ALT0 | SCU.DSC.POR_B | INPUT | PU(50K) |
| AK14 | QSPI0A_DATA0 | VDD_QSPI0A_1P8_3P3 | FASTD | ALT0 | LSIO.QSPI0A.DATA0 | INPUT | PD(50K) |
| AR13 | QSPI0A_DATA1 | VDD_QSPI0A_1P8_3P3 | FASTD | ALT0 | LSIO.QSPI0A.DATA1 | INPUT | PD(50K) |
| AJ13 | QSPI0A_DATA2 | VDD_QSPI0A_1P8_3P3 | FASTD | ALT0 | LSIO.QSPI0A.DATA2 | INPUT | PD(50K) |

Table 125. 21 x 21 mm functional contact assignments (continued)

| Ball | Ball Name | Power Domain | Ball Type ₁ | Reset Condition ² | | | |
|------|---------------------------|----------------------------|------------------------|------------------------------|----------------------|-------------------|--------------|
| | | | | Default Mode | Default Function | Default Direction | Default Pull |
| AH12 | QSPI0A_DATA3 | VDD_QSPI0A_1P8_3P3 | FASTD | ALT0 | LSIO.QSPI0A.DATA3 | INPUT | PD(50K) |
| AL11 | QSPI0A_DQS | VDD_QSPI0A_1P8_3P3 | FASTD | ALT0 | LSIO.QSPI0A.DQS | INPUT | PD(50K) |
| AP12 | QSPI0A_SCLK | VDD_QSPI0A_1P8_3P3 | FASTD | ALT4 | LSIO.GPIO3.IO16 | INPUT | PD(50K) |
| AM12 | QSPI0A_SS0_B | VDD_QSPI0A_1P8_3P3 | FASTD | ALT4 | LSIO.GPIO3.IO14 | INPUT | PU(50K) |
| AK12 | QSPI0A_SS1_B | VDD_QSPI0A_1P8_3P3 | FASTD | ALT4 | LSIO.GPIO3.IO15 | INPUT | PU(50K) |
| AM10 | QSPI0B_DATA0 | VDD_QSPI0B_1P8_3P3 | FASTD | ALT0 | LSIO.QSPI0B.DATA0 | INPUT | PD(50K) |
| AL9 | QSPI0B_DATA1 | VDD_QSPI0B_1P8_3P3 | FASTD | ALT0 | LSIO.QSPI0B.DATA1 | INPUT | PD(50K) |
| AJ11 | QSPI0B_DATA2 | VDD_QSPI0B_1P8_3P3 | FASTD | ALT0 | LSIO.QSPI0B.DATA2 | INPUT | PD(50K) |
| AM8 | QSPI0B_DATA3 | VDD_QSPI0B_1P8_3P3 | FASTD | ALT0 | LSIO.QSPI0B.DATA3 | INPUT | PD(50K) |
| AK10 | QSPI0B_DQS | VDD_QSPI0B_1P8_3P3 | FASTD | ALT0 | LSIO.QSPI0B.DQS | INPUT | PD(50K) |
| AR11 | QSPI0B_SCLK | VDD_QSPI0B_1P8_3P3 | FASTD | ALT4 | LSIO.GPIO3.IO17 | INPUT | PD(50K) |
| AH10 | QSPI0B_SS0_B | VDD_QSPI0B_1P8_3P3 | FASTD | ALT4 | LSIO.GPIO3.IO23 | INPUT | PU(50K) |
| AJ9 | QSPI0B_SS1_B | VDD_QSPI0B_1P8_3P3 | FASTD | ALT4 | LSIO.GPIO3.IO24 | INPUT | PU(50K) |
| AP32 | RTC_XTALI | VDD_SNVS_LDO_1P8_CAP | ANA | | SNVS.RTC_XTALI | | |
| AM32 | RTC_XTALO | VDD_SNVS_LDO_1P8_CAP | ANA | | SNVS.RTC_XTALO | | |
| M34 | SAI0_RXD | VDD_SPI_SAI_1P8_3P3 | GPIO | ALT0 | ADMA.SAI0.RXD | INPUT | PD(50K) |
| J35 | SAI0_TXC | VDD_SPI_SAI_1P8_3P3 | GPIO | ALT0 | ADMA.SAI0.TXC | INPUT | PD(50K) |
| K34 | SAI0_TXD | VDD_SPI_SAI_1P8_3P3 | GPIO | ALT0 | ADMA.SAI0.TXD | INPUT | PD(50K) |
| L33 | SAI0_TXFS | VDD_SPI_SAI_1P8_3P3 | GPIO | ALT0 | ADMA.SAI0.TXFS | INPUT | PD(50K) |
| L35 | SAI1_RXC | VDD_SPI_SAI_1P8_3P3 | GPIO | ALT0 | ADMA.SAI1.RXC | INPUT | PD(50K) |
| M32 | SAI1_RXD | VDD_SPI_SAI_1P8_3P3 | GPIO | ALT0 | ADMA.SAI1.RXD | INPUT | PD(50K) |
| N35 | SAI1_RXFS | VDD_SPI_SAI_1P8_3P3 | GPIO | ALT0 | ADMA.SAI1.RXFS | INPUT | PD(50K) |
| AJ31 | SCU_BOOT_MODE0 | VDD_ANA1_1P8 | SCU | ALT0 | SCU.DSC.BOOT_MODE0 | INPUT | PD(50K) |
| AK32 | SCU_BOOT_MODE1 | VDD_ANA1_1P8 | SCU | ALT0 | SCU.DSC.BOOT_MODE1 | INPUT | PD(50K) |
| AL31 | SCU_BOOT_MODE2 | VDD_ANA1_1P8 | SCU | ALT0 | SCU.DSC.BOOT_MODE2 | INPUT | PD(50K) |
| AJ29 | SCU_BOOT_MODE3 | VDD_ANA1_1P8 | SCU | ALT0 | SCU.DSC.BOOT_MODE3 | INPUT | PD(50K) |
| AF28 | SCU_GPIO0_00 | VDD_ANA1_1P8 | GPIO | ALT0 | SCU.GPIO0.IO00 | INPUT | PD(50K) |
| AH30 | SCU_GPIO0_01 | VDD_ANA1_1P8 | GPIO | ALT0 | SCU.GPIO0.IO01 | INPUT | PU(50K) |
| AG29 | SCU_PMIC_STANDBY | VDD_ANA1_1P8 | SCU | ALT0 | SCU.DSC.PMIC_STANDBY | OUTPUT | HiZ |
| AD28 | SCU_WDOG_OUT ³ | VDD_ANA1_1P8 | SCU | ALT1 | SCU.WDOG0.WDOG_OUT | OUTPUT | PD(50K) |
| E35 | SPDIF0_EXT_CLK | VDD_ESAI_SPDIF_1P8_2P5_3P3 | GPIO | ALT0 | ADMA.SPDIF0.EXT_CLK | INPUT | PD(50K) |
| G31 | SPDIF0_RX | VDD_ESAI_SPDIF_1P8_2P5_3P3 | GPIO | ALT0 | ADMA.SPDIF0.RX | INPUT | PD(50K) |
| D34 | SPDIF0_TX | VDD_ESAI_SPDIF_1P8_2P5_3P3 | GPIO | ALT4 | LSIO.GPIO0.IO11 | INPUT | PD(50K) |
| R33 | SPI0_CS0 | VDD_SPI_SAI_1P8_3P3 | GPIO | ALT0 | ADMA.SPI0.CS0 | INPUT | PD(50K) |
| R35 | SPI0_CS1 | VDD_SPI_SAI_1P8_3P3 | GPIO | ALT0 | ADMA.SPI0.CS1 | INPUT | PD(50K) |

Table 125. 21 x 21 mm functional contact assignments (continued)

| Ball | Ball Name | Power Domain | Ball Type ₁ | Reset Condition ² | | | |
|------|------------------|---------------------------|------------------------|------------------------------|--------------------------|-------------------|--------------|
| | | | | Default Mode | Default Function | Default Direction | Default Pull |
| P30 | SPI0_SCK | VDD_SPI_SAI_1P8_3P3 | GPIO | ALT0 | ADMA.SPI0.SCK | INPUT | PD(50K) |
| P34 | SPI0_SDI | VDD_SPI_SAI_1P8_3P3 | GPIO | ALT0 | ADMA.SPI0.SDI | INPUT | PD(50K) |
| R31 | SPI0_SDO | VDD_SPI_SAI_1P8_3P3 | GPIO | ALT4 | LSIO.GPIO1.IO06 | INPUT | PD(50K) |
| P28 | SPI2_CS0 | VDD_SPI_SAI_1P8_3P3 | GPIO | ALT0 | ADMA.SPI2.CS0 | INPUT | PD(50K) |
| R29 | SPI2_SCK | VDD_SPI_SAI_1P8_3P3 | GPIO | ALT0 | ADMA.SPI2.SCK | INPUT | PD(50K) |
| N31 | SPI2_SDI | VDD_SPI_SAI_1P8_3P3 | GPIO | ALT0 | ADMA.SPI2.SDI | INPUT | PD(50K) |
| P32 | SPI2_SDO | VDD_SPI_SAI_1P8_3P3 | GPIO | ALT4 | LSIO.GPIO1.IO01 | INPUT | PD(50K) |
| J31 | SPI3_CS0 | VDD_SPI_MCLK_UART_1P8_3P3 | GPIO | ALT0 | ADMA.SPI3.CS0 | INPUT | PD(50K) |
| K30 | SPI3_CS1 | VDD_SPI_MCLK_UART_1P8_3P3 | GPIO | ALT0 | ADMA.SPI3.CS1 | INPUT | PD(50K) |
| H32 | SPI3_SCK | VDD_SPI_MCLK_UART_1P8_3P3 | GPIO | ALT0 | ADMA.SPI3.SCK | INPUT | PD(50K) |
| G33 | SPI3_SDI | VDD_SPI_MCLK_UART_1P8_3P3 | GPIO | ALT0 | ADMA.SPI3.SDI | INPUT | PD(50K) |
| F34 | SPI3_SDO | VDD_SPI_MCLK_UART_1P8_3P3 | GPIO | ALT4 | LSIO.GPIO0.IO14 | INPUT | PD(50K) |
| AE29 | TEST_MODE_SELECT | VDD_ANA1_1P8 | SCU | ALT0 | SCU.TCU.TEST_MODE_SELECT | INPUT | PD(50K) |
| AB32 | UART0_RX | VDD_CAN_UART_1P8_3P3 | GPIO | ALT0 | ADMA.UART0.RX | INPUT | PD(50K) |
| AA29 | UART0_TX | VDD_CAN_UART_1P8_3P3 | GPIO | ALT4 | LSIO.GPIO1.IO22 | INPUT | PD(50K) |
| K32 | UART1_CTS_B | VDD_SPI_MCLK_UART_1P8_3P3 | GPIO | ALT0 | ADMA.UART1.CTS_B | INPUT | PD(50K) |
| N29 | UART1_RTS_B | VDD_SPI_MCLK_UART_1P8_3P3 | GPIO | ALT4 | LSIO.GPT0.CLK | INPUT | PD(50K) |
| L31 | UART1_RX | VDD_SPI_MCLK_UART_1P8_3P3 | GPIO | ALT0 | ADMA.UART1.RX | INPUT | PD(50K) |
| H34 | UART1_TX | VDD_SPI_MCLK_UART_1P8_3P3 | GPIO | ALT4 | LSIO.GPIO0.IO21 | INPUT | PD(50K) |
| AD34 | UART2_RX | VDD_CAN_UART_1P8_3P3 | GPIO | ALT0 | ADMA.UART2.RX | INPUT | PD(50K) |
| AC35 | UART2_TX | VDD_CAN_UART_1P8_3P3 | GPIO | ALT4 | LSIO.GPIO1.IO23 | INPUT | PD(50K) |
| E19 | USB_OTG1_DN | VDD_USB_3P3 | OTG | | CONN.USB_OTG1.DN | | |
| D18 | USB_OTG1_DP | VDD_USB_3P3 | OTG | | CONN.USB_OTG1.DP | | |
| G17 | USB_OTG1_ID | VDD_USB_3P3 | OTG | | CONN.USB_OTG1.ID | | |
| H18 | USB_OTG1_VBUS | | OTG | | CONN.USB_OTG1.VBUS | | |
| D16 | USB_OTG2_DN | VDD_USB_3P3 | OTG | | CONN.USB_OTG2.DM | | |
| E17 | USB_OTG2_DP | VDD_USB_3P3 | OTG | | CONN.USB_OTG2.DP | | |
| F16 | USB_OTG2_ID | VDD_USB_3P3 | OTG | | CONN.USB_OTG2.ID | | |
| D14 | USB_OTG2_REXT | VDD_USB_3P3 | OTG | | CONN.USB_OTG2.RTRIM | | |
| H16 | USB_OTG2_VBUS | | OTG | | CONN.USB_OTG2.VBUS | | |
| E13 | USB_SS3_REXT | VDD_USB_1P8 | USB3 | | CONN.USB_SS3.REXT | | |
| B18 | USB_SS3_RX_N | VDD_USB_SS3_LDO_1P0_CAP | USB3 | | CONN.USB_SS3.RX_M_LN_0 | | Hi-Z |
| A19 | USB_SS3_RX_P | VDD_USB_SS3_LDO_1P0_CAP | USB3 | | CONN.USB_SS3.RX_P_LN_0 | | Hi-Z |
| F14 | USB_SS3_TC0 | VDD_USB_3P3 | GPIO | ALT0 | ADMA.I2C1.SCL | INPUT | PD(50K) |
| H14 | USB_SS3_TC1 | VDD_USB_3P3 | GPIO | ALT0 | ADMA.I2C1.SCL | INPUT | PD(50K) |

Table 125. 21 x 21 mm functional contact assignments (continued)

| Ball | Ball Name | Power Domain | Ball Type ¹ | Reset Condition ² | | | |
|------|----------------|----------------------------|------------------------|------------------------------|------------------------|-------------------|--------------|
| | | | | Default Mode | Default Function | Default Direction | Default Pull |
| G15 | USB_SS3_TC2 | VDD_USB_3P3 | GPIO | ALT0 | ADMA.I2C1.SDA | INPUT | PD(50K) |
| C15 | USB_SS3_TC3 | VDD_USB_3P3 | GPIO | ALT0 | ADMA.I2C1.SDA | INPUT | PD(50K) |
| A15 | USB_SS3_TX_N | VDD_USB_SS3_LDO_1P0_CAP | USB3 | | CONN.USB_SS3.TX_M_LN_0 | | |
| B16 | USB_SS3_TX_P | VDD_USB_SS3_LDO_1P0_CAP | USB3 | | CONN.USB_SS3.TX_P_LN_0 | | |
| E23 | USDHC1_CD_B | VDD_USDHC1_VSELECT_1P8_3P3 | FASTD | ALT0 | CONN.USDHC1.CD_B | INPUT | PU(50K) |
| G23 | USDHC1_CLK | VDD_USDHC1_1P8_3P3 | FASTD | ALT4 | LSIO.GPIO4.IO23 | INPUT | PD(50K) |
| C25 | USDHC1_CMD | VDD_USDHC1_1P8_3P3 | FASTD | ALT0 | CONN.USDHC1.CMD | INPUT | PU(50K) |
| A27 | USDHC1_DATA0 | VDD_USDHC1_1P8_3P3 | FASTD | ALT0 | CONN.USDHC1.DATA0 | INPUT | PU(50K) |
| B26 | USDHC1_DATA1 | VDD_USDHC1_1P8_3P3 | FASTD | ALT0 | CONN.USDHC1.DATA1 | INPUT | PU(50K) |
| D26 | USDHC1_DATA2 | VDD_USDHC1_1P8_3P3 | FASTD | ALT0 | CONN.USDHC1.DATA2 | INPUT | PU(50K) |
| E25 | USDHC1_DATA3 | VDD_USDHC1_1P8_3P3 | FASTD | ALT0 | CONN.USDHC1.DATA3 | INPUT | PU(50K) |
| B24 | USDHC1_RESET_B | VDD_USDHC1_VSELECT_1P8_3P3 | FASTD | ALT4 | LSIO.GPIO4.IO19 | INPUT | PU(50K) |
| A25 | USDHC1_VSELECT | VDD_USDHC1_VSELECT_1P8_3P3 | FASTD | ALT4 | LSIO.GPIO4.IO20 | INPUT | PD(50K) |
| D24 | USDHC1_WP | VDD_USDHC1_VSELECT_1P8_3P3 | FASTD | ALT0 | CONN.USDHC1.WP | INPUT | PD(50K) |
| AP34 | XTALI | VDD_ANA1_1P8 | ANA | | SCU.DSC.XTALI | | |
| AM34 | XTALO | VDD_ANA1_1P8 | ANA | | SCU.DSC.XTALO | | |

¹ FASTD are GPIO balls configured for high speed operation using the FASTRZ control.

² Reset condition shown is before boot code execution. For pad changes after boot code execution, see the System Boot chapter of the device reference manual.

³ SCU_WDOG_OUT was previously named JTAG_TRST_B; it has been renamed because its functionality has changed.

Package information and contact assignments

The following table shows DDR pin function.

Table 126. DRAM pin function

| Ball Name | Ball | LPDDR4 function | DDR3L function |
|-----------|------|-----------------|----------------|
| DDR_ATO | AB8 | — | — |
| DDR_CK0_N | Y6 | DDR_CK0_N | DDR_CK0_N |
| DDR_CK0_P | W5 | DDR_CK0_P | DDR_CK0_P |
| DDR_CK1_N | N5 | DDR_CK1_N | DDR_CK1_N |
| DDR_CK1_P | P6 | DDR_CK1_P | DDR_CK1_P |
| DDR_DCF00 | W1 | CA2_A | A5 |
| DDR_DCF01 | U3 | CA4_A | A6 |
| DDR_DCF03 | U1 | CA5_A | A7 |
| DDR_DCF04 | U7 | — | A8 |
| DDR_DCF05 | U5 | — | A9 |
| DDR_DCF07 | T2 | — | RAS# |
| DDR_DCF08 | AB4 | CA3_A | A3 |
| DDR_DCF09 | AB6 | ODT_CA_A | ODT |
| DDR_DCF10 | AC5 | CS0_A | A1 |
| DDR_DCF11 | W3 | CA0_A | A0 |
| DDR_DCF12 | Y8 | CS1_A | A2 |
| DDR_DCF14 | Y2 | CKE0_A | — |
| DDR_DCF15 | Y4 | CKE1_A | — |
| DDR_DCF16 | W7 | CA1_A | A4 |
| DDR_DCF17 | N3 | CA4_B | A12 |
| DDR_DCF18 | L1 | RESET_N | RESET_N |
| DDR_DCF19 | N1 | CA5_B | A14 |
| DDR_DCF20 | P4 | — | A15 |
| DDR_DCF21 | T8 | — | BA0 |
| DDR_DCF22 | P2 | — | BA1 |
| DDR_DCF23 | T4 | — | BA2 |
| DDR_DCF24 | T6 | — | CAS# |
| DDR_DCF25 | K8 | ODT_CA_B | ODT1 |
| DDR_DCF26 | L7 | CA3_B | A13 |
| DDR_DCF27 | K4 | CA0_B | A10 |
| DDR_DCF28 | K6 | CS0_B | CS_N[0] |

Table 126. DRAM pin function (continued)

| Ball Name | Ball | LPDDR4 function | DDR3L function |
|-----------|------|-----------------|----------------|
| DDR_DCF29 | K2 | CS1_B | CS_N[1] |
| DDR_DCF30 | N7 | CKE0_B | CKE0 |
| DDR_DCF31 | L5 | CKE1_B | CKE1 |
| DDR_DCF32 | L3 | CA1_B | A11 |
| DDR_DCF33 | P8 | CA2_B | WE# |
| DDR_DM0 | AJ7 | DDR_DMI0 | DDR_DMI0 |
| DDR_DM1 | AF4 | DDR_DMI1 | DDR_DMI1 |
| DDR_DM2 | D4 | DDR_DMI2 | DDR_DMI2 |
| DDR_DM3 | E1 | DDR_DMI3 | DDR_DMI3 |
| DDR_DM4 | AP6 | — | DDR_DMI4 |
| DDR_DQ00 | AF6 | DDR_DQ00 | DDR_DQ00 |
| DDR_DQ01 | AE5 | DDR_DQ01 | DDR_DQ01 |
| DDR_DQ02 | AH8 | DDR_DQ02 | DDR_DQ02 |
| DDR_DQ03 | AF8 | DDR_DQ03 | DDR_DQ03 |
| DDR_DQ04 | AM4 | DDR_DQ04 | DDR_DQ04 |
| DDR_DQ05 | AM6 | DDR_DQ05 | DDR_DQ05 |
| DDR_DQ06 | AL5 | DDR_DQ06 | DDR_DQ06 |
| DDR_DQ07 | AL7 | DDR_DQ07 | DDR_DQ07 |
| DDR_DQ08 | AJ1 | DDR_DQ08 | DDR_DQ08 |
| DDR_DQ09 | AJ3 | DDR_DQ09 | DDR_DQ09 |
| DDR_DQ10 | AH2 | DDR_DQ10 | DDR_DQ10 |
| DDR_DQ11 | AH4 | DDR_DQ11 | DDR_DQ11 |
| DDR_DQ12 | AC3 | DDR_DQ12 | DDR_DQ12 |
| DDR_DQ13 | AE3 | DDR_DQ13 | DDR_DQ13 |
| DDR_DQ14 | AB2 | DDR_DQ14 | DDR_DQ14 |
| DDR_DQ15 | AC1 | DDR_DQ15 | DDR_DQ15 |
| DDR_DQ16 | B6 | DDR_DQ16 | DDR_DQ16 |
| DDR_DQ17 | E9 | DDR_DQ17 | DDR_DQ17 |
| DDR_DQ18 | E7 | DDR_DQ18 | DDR_DQ18 |
| DDR_DQ19 | D8 | DDR_DQ19 | DDR_DQ19 |
| DDR_DQ20 | G7 | DDR_DQ20 | DDR_DQ20 |
| DDR_DQ21 | H8 | DDR_DQ21 | DDR_DQ21 |
| DDR_DQ22 | H6 | DDR_DQ22 | DDR_DQ22 |

Table 126. DRAM pin function (continued)

| Ball Name | Ball | LPDDR4 function | DDR3L function |
|------------|------|-----------------|----------------|
| DDR_DQ23 | G5 | DDR_DQ23 | DDR_DQ23 |
| DDR_DQ24 | H2 | DDR_DQ24 | DDR_DQ24 |
| DDR_DQ25 | H4 | DDR_DQ25 | DDR_DQ25 |
| DDR_DQ26 | G3 | DDR_DQ26 | DDR_DQ26 |
| DDR_DQ27 | G1 | DDR_DQ27 | DDR_DQ27 |
| DDR_DQ28 | A7 | DDR_DQ28 | DDR_DQ28 |
| DDR_DQ29 | B4 | DDR_DQ29 | DDR_DQ29 |
| DDR_DQ30 | B2 | DDR_DQ30 | DDR_DQ30 |
| DDR_DQ31 | A5 | DDR_DQ31 | DDR_DQ31 |
| DDR_DQ32 | AL1 | — | DDR_DQ32 |
| DDR_DQ33 | AM2 | — | DDR_DQ33 |
| DDR_DQ34 | AL3 | — | DDR_DQ34 |
| DDR_DQ35 | AP2 | — | DDR_DQ35 |
| DDR_DQ36 | AP8 | — | DDR_DQ36 |
| DDR_DQ37 | AP10 | — | DDR_DQ37 |
| DDR_DQ38 | AR9 | — | DDR_DQ38 |
| DDR_DQ39 | AR7 | — | DDR_DQ39 |
| DDR_DQS0_N | AH6 | DDR_DQS0_N | DDR_DQS0_N |
| DDR_DQS0_P | AJ5 | DDR_DQS0_P | DDR_DQS0_P |
| DDR_DQS1_N | AE1 | DDR_DQS1_N | DDR_DQS1_N |
| DDR_DQS1_P | AF2 | DDR_DQS1_P | DDR_DQS1_P |
| DDR_DQS2_N | E5 | DDR_DQS2_N | DDR_DQS2_N |
| DDR_DQS2_P | D6 | DDR_DQS2_P | DDR_DQS2_P |
| DDR_DQS3_N | E3 | DDR_DQS3_N | DDR_DQS3_N |
| DDR_DQS3_P | D2 | DDR_DQS3_P | DDR_DQS3_P |
| DDR_DQS4_N | AR5 | — | DDR_DQS4_N |
| DDR_DQS4_P | AP4 | — | DDR_DQS4_P |
| DDR.DTO0 | AC7 | — | — |
| DDR.DTO1 | AE7 | — | — |
| DDR.VREF | AD8 | — | — |
| DDR.ZQ | G9 | — | — |

6.2 FCPBGA, 17 x 17 mm, 0.8 mm pitch

This section includes the following:

- Mechanical package drawing
- Ball map for case FCPBGA, 17 x 17 mm, 0.8 mm pitch
- Contact assignments

6.2.1 17 x 17 mm package case outline

The following figure shows the top, bottom, and side views of the 17 x 17 mm package.

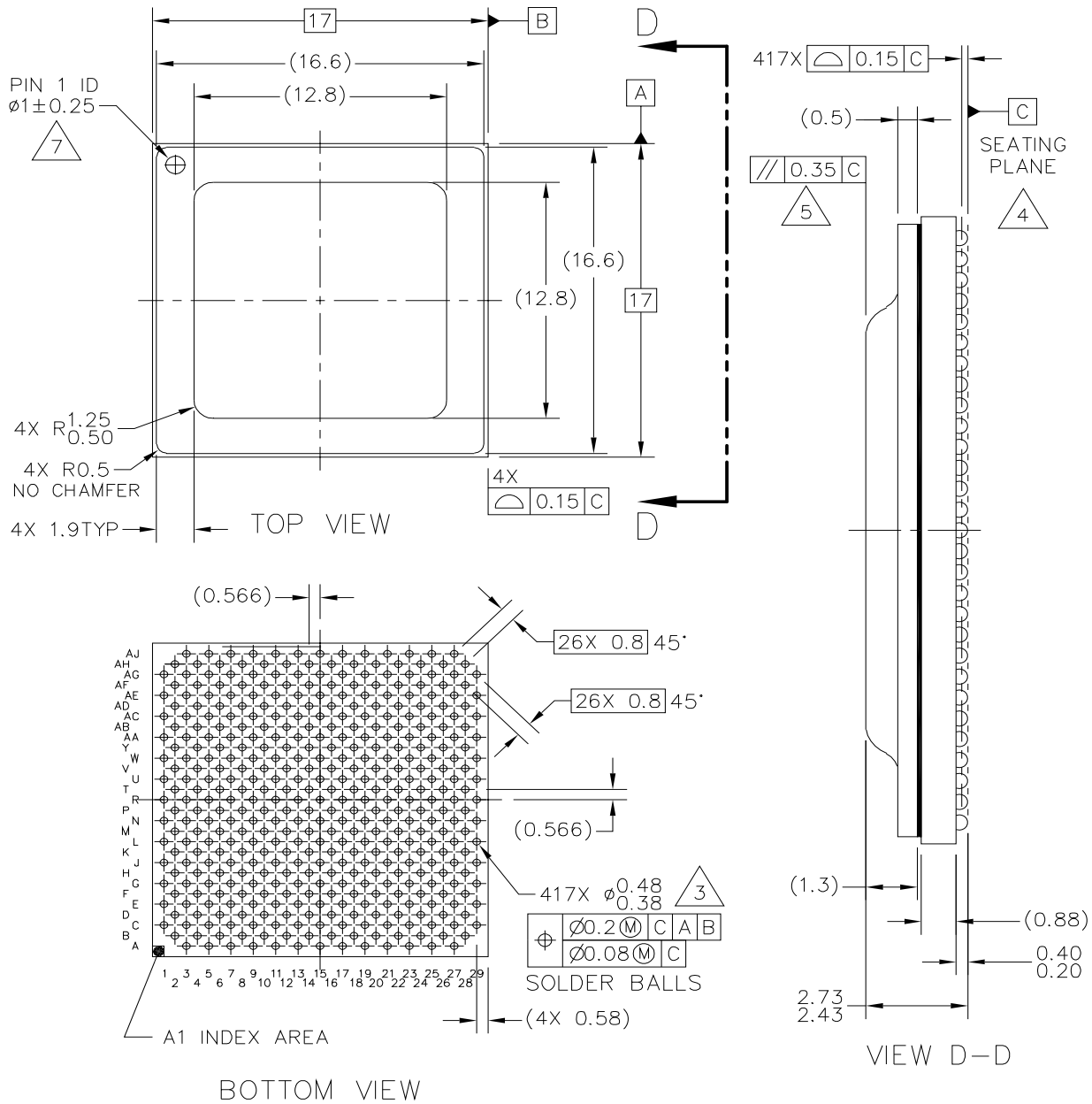

RELEASED FOR EXTERNAL ASSEMBLY ONLY. THIS DESIGN ONLY MEETS EXTERNAL DESIGN AND ASSEMBLY RULES. MUST BE REVIEWED AND UPDATED BEFORE BEING ASSEMBLED INTERNALLY.

| | | |
|--|--------------------------|---------------|
| TITLE: FCPBGA, WITH LID, 17 X 17 X 2.58 PKG, 0.8 MM PITCH, 417 I/O INTERSTITIAL | DOCUMENT NO: 98ASA01087D | REV: A |
| | STANDARD: NON-JEDEC | |
| | SOT1932-1 | SHEET: 1 OF 3 |

Figure 60. 17 x 17 mm Package Top, Bottom, and Side Views

The following notes pertain to the preceding figure, “17 x 17 mm Package Top, Bottom, and Side Views.”

NOTES:

1. ALL DIMENSIONS IN MILLIMETERS.
2. DIMENSIONING AND TOLERANCING PER ASME Y14.5M–1994.
3. MAXIMUM SOLDER BALL DIAMETER MEASURED PARALLEL TO DATUM C.
4. DATUM C, THE SEATING PLANE, IS DETERMINED BY THE SPHERICAL CROWNS OF THE SOLDER BALLS.
5. PARALLELISM MEASUREMENT SHALL EXCLUDE ANY EFFECT OF MARK ON TOP SURFACE OF PACKAGE.
6. ALL DIMENSIONS ARE SYMMETRIC ACROSS THE PACKAGE CENTER LINES, UNLESS DIMENSIONED OTHERWISE.
7. PIN 1 THRU HOLE SHALL BE CENTERED WITHIN FOOT AREA.
8. LID OVERHANG ON SUBSTRATE NOT ALLOWED.

Figure 61. Notes on 17 x 17 mm Package Top, Bottom, and Side Views

6.2.2 17 x 17 mm, 0.8 mm pitch, ball map

The following page shows the 17 x 17 mm, 0.8 mm pitch, ball map.

Package information and functional contact assignments for FCPBGA, 17 x 17 mm, 0.8 mm pitch

| | 1 | 2 | 3 | 4 | 5 | 6 | 7 | 8 | 9 | 10 | 11 | 12 | 13 | 14 | 15 | 16 | 17 | 18 | 19 | 20 | 21 | 22 | 23 | 24 | 25 | 26 | 27 | 28 | 29 | | |
|----|---------------|---------------|---------------|---------------|--------------------|--------------|--------------------|--------------------|----------------------|--------------------|----------------------------|-------------------------|--------------------|--------------------|--------------------|--------------------|--------------------|-------------------------------|---------------------------|--------------------|-----------------------|-----------------------|----------------------|------------------|--------------------|----------------------------|---------------------------|--------------------|--------------|----------|-------------|
| A | | | VSS_MAIN | | DDR_DCF18 | | DDR_CK1_P | | DDR_DCF26 | | PCIE_CTRL0_PERST_B | | PCIE0_TX0_P | | PCIE0_RX0_P | | USB_OTG1_ID | | USB_OTG1_D_P | | EMMC0_DAT_A0 | | ENETO_RGMII_RXC | | ENETO_MDC | | VSS_MAIN | | | | |
| B | | DDR_DCF01 | | DDR_DCF07 | | DDR_DCF17 | | DDR_CK1_N | | DDR_DCF21 | | PCIE0_TX0_N | | PCIE_CTRL0_WAKE_B | | PCIE0_RX0_N | | USB_OTG1_D_N | | EMMC0_RES_ET_B | | ENETO_RGMII_TXD3 | | ENETO_RGMII_RXD3 | | ESAI0_FSR | | ESAI0_TX4_RX1 | | | |
| C | VSS_MAIN | | VSS_MAIN | | VSS_MAIN | | VSS_MAIN | | VSS_MAIN | | VSS_MAIN | | PCIE_REFCLK_100M_N | | VSS_MAIN | | VSS_MAIN | | VDD_EMMC0_VSELECT_1P8_3P3 | | ENETO_RGMII_TXD1 | | ENETO_RGMII_RXD0 | | ESAI0_SCKT | | ESAI0_TX2_RX3 | | VSS_MAIN | | |
| D | | DDR_DCF12 | | DDR_DCF05 | | DDR_DCF20 | | DDR_DCF29 | | DDR_DCF28 | | VDD_USB_SS3_LDO_1P0_CAP | | PCIE_REFCLK_100M_P | | VDD_EMMC0_1P8_3P3 | | VDD_ENETO_VSELECT_1P8_2P5_3P3 | | ENETO_RGMII_RXD1 | | ENETO_RGMII_TXD1 | | ESAI0_TX3_RX2 | | SPI3_CS0 | | SPI3_CS0 | | SPI3_SCK | |
| E | DDR_DCF15 | | DDR_DCF03 | | DDR_DCF22 | | DDR_DCF32 | | DDR_DCF27 | | PCIE_CTRL0_CLKREQ_B | | EMMC0_CMD | | EMMC0_DAT_A6 | | VSS_MAIN | | EMMC0_DAT_A3 | | VDD_ENETO_1P8_2P5_3P3 | | ESAI0_FST | | ESAI0_TX1 | | SPDIF0_EXT_CLK | | UART1_RX | | |
| F | | VSS_MAIN | | VSS_MAIN | | VSS_MAIN | | VSS_MAIN | | DDR_ZQ | | PCIE_REF_QR | | EMMC0_CLK | | EMMC0_DAT_A5 | | EMMC0_DAT_A1 | | ENETO_RGMII_TXD0 | | ENETO_REFCLK_125M_25% | | SPDIF0_RX | | VDD_ENETO_MDIO_1P8_3P3 | | SPI3_CS1 | | | |
| G | DDR_DCF10 | | DDR_CK0_N | | DDR_DCF00 | | DDR_DCF33 | | DDR_DCF31 | | PCIE0_PHY_P_LL_REF_RETUR_N | | USB_SS3_TC1 | | EMMC0_DAT_A2 | | EMMC0_DAT_A4 | | ENETO_RGMII_TXC | | ENETO_RGMII_RXD2 | | ESAI0_TX0 | | SPI3_SDO | | UART1_CTS_B | | UART1_RTS_B | | |
| H | | DDR_CK0_P | | DDR_DCF24 | | DDR_DCF19 | | DDR_DCF30 | | DDR_DCF25 | | PCIE_REXT | | USB_SS3_TC3 | | EMMC0_DAT_A7 | | ENETO_RGMII_TX_CTL | | ENETO_RGMII_RX_CTL | | ESAI0_SCKR | | SPI3_SDI | | VSS_MAIN | | SPI0_CS0 | | | |
| J | VSS_MAIN | | VSS_MAIN | | VSS_MAIN | | VSS_MAIN | | VDD_PCIE_D1G_1P8_3P3 | | VDD_PCIE_1P8 | | VSS_MAIN | | USB_OTG1_VBUS | | EMMC0_STR_OBE | | ENETO_RGMII_TXD2 | | ENETO_MDIO | | SPDIF0_TX | | UART1_TX | | SPI0_SDO | | SPI0_SDI | | |
| K | | DDR_DCF08 | | DDR_DCF14 | | DDR_DCF04 | | VDD_DDR_VDDQ | | VDD_ANA0_1P8 | | VDD_PCIE_LDO_1P0_CAP | | VDD_USB_1P8 | | VDD_MAIN | | VSS_MAIN | | VDD_GPU | | ESAI0_TX5_RX0 | | MCLK_OUT0 | | VDD_ESAI_SPDIF_1P8_2P5_3P3 | | SPI0_CS1 | | | |
| L | DDR_DCF11 | | DDR_DCF09 | | DDR_DCF23 | | DDR_DCF16 | | VSS_MAIN | | VSS_MAIN | | VDD_MAIN | | VSS_MAIN | | VDD_GPU | | VDD_GPU | | VDD_MAIN | | MCLK_IN0 | | SPI0_SCK | | VDD_SPI_MCLK_UART_1P8_3P3 | | VSS_MAIN | | |
| M | | VSS_MAIN | | VSS_MAIN | | VSS_MAIN | | VDD_DDR_VDDQ | | VDD_MAIN | | VSS_MAIN | | VDD_MAIN | | VSS_MAIN | | VDD_GPU | | VSS_MAIN | | MCLK_IN1 | | VSS_MAIN | | VSS_MAIN | | ADC_VREFH | | | |
| N | DDR_DQ02 | | DDR_DQ00 | | DDR_DQ13 | | DDR_DQ15 | | VDD_DDR_VDDQ | | VDD_MAIN | | VSS_MAIN | | VDD_MAIN | | VSS_MAIN | | VDD_GPU | | VSS_MAIN | | ADC_IN1 | | ADC_IN3 | | ADC_IN2 | | ADC_VREFL | | |
| P | | DDR_DQ01 | | DDR_DQ12 | | DDR_DQ14 | | VDD_DDR_VDDQ | | VSS_MAIN | | VDD_MAIN | | VSS_MAIN | | VDD_MAIN | | VSS_MAIN | | VDD_GPU | | VDD_GPU | | VDD_ADC_1P8 | | ADC_IN0 | | ADC_IN5 | | ADC_IN4 | |
| R | VSS_MAIN | | VSS_MAIN | | VSS_MAIN | | VSS_MAIN | | VSS_MAIN | | VSS_MAIN | | VDD_MAIN | | VSS_MAIN | | VDD_GPU | | VSS_MAIN | | VDD_MAIN | | VSS_MAIN | | VSS_MAIN | | VSS_MAIN | | VSS_MAIN | | VSS_MAIN |
| T | | DDR_DQ03 | | DDR_DQ51_N | | DDR_DM1 | | VDD_DDR_VDDQ | | VDD_MAIN | | VSS_MAIN | | VDD_MAIN | | VSS_MAIN | | VDD_GPU | | VSS_MAIN | | FLEXCAN0_RX | | FLEXCAN1_RX | | VDD_ADC_D1G_1P8 | | FLEXCAN2_RX | | | |
| U | DDR_DQ50_N | | DDR_DQ50_P | | DDR_DQ51_P | | DDR_DTO0 | | VDD_DDR_VDDQ | | VDD_MAIN | | VSS_MAIN | | VDD_MAIN | | VSS_MAIN | | VDD_MAIN | | VSS_MAIN | | VDD_CAN_UART_1P8_3P3 | | UART0_TX | | FLEXCAN0_TX | | FLEXCAN2_TX | | FLEXCAN1_TX |
| V | | VSS_MAIN | | VSS_MAIN | | VSS_MAIN | | VDD_DDR_VDDQ | | VSS_MAIN | | VDD_A35 | | VDD_A35 | | VDD_A35 | | VSS_MAIN | | VDD_MAIN | | MIPI_DSIO_I2C0_SDA | | VSS_MAIN | | UART2_TX | | UART0_RX | | | |
| W | DDR_DM0 | | DDR_DQ10 | | DDR_ATO | | VDD_DDR_PL1_1P8 | | VSS_MAIN | | VSS_MAIN | | VDD_A35 | | VDD_A35 | | VDD_A35 | | VSS_MAIN | | VDD_ANA1_1P8 | | JTAG_TMS | | MIPI_DSIO_I2C0_SDA | | MIPI_DSIO_I2C0_SCL | | UART2_RX | | |
| Y | | DDR_DQ04 | | DDR_DQ08 | | DDR_VREF | | VDD_DDR_VDDQ | | VDD_MAIN | | VSS_MAIN | | VDD_MAIN | | VSS_MAIN | | VDD_MAIN | | VSS_MAIN | | SCU_GPIO0_0 | | JTAG_TDO | | VDD_SNV5_4P2 | | MIPI_DSIO_I2C0_SCL | | | |
| AA | VSS_MAIN | | VSS_MAIN | | VSS_MAIN | | VSS_MAIN | | VDD_DDR_VDDQ | | VDD_MAIN | | VDD_MIPI_1P8 | | VDD_MIPI_1P0 | | VSS_MAIN | | VDD_MAIN | | VSS_MAIN | | VDD_TMR_CSI_1P8_3P3 | | PMIC_INT_B | | TEST_MODE_SELECT | | VSS_MAIN | | JTAG_TCK |
| AB | | DDR_DQ05 | | DDR_DQ11 | | DDR_DTO1 | | VDD_DDR_VDDQ | | QSPI0A_DQS | | QSPI0A_SS0_B | | VDD_MIPI_1P8 | | VDD_MIPI_1P0 | | VDD_MIPI_CSI_1DIG_1P8 | | PMIC_ON_REQ | | SCU_BOOT_MODE3 | | SCU_PMIC_STANDBY | | VDD_SNV5_1DO_1P8_CAP | | SCU_WDOG_OUT | | | |
| AC | DDR_DQ06 | | DDR_DQ07 | | DDR_DQ09 | | QSPI0B_DAT_A0 | | QSPI0A_DAT_A2 | | MIPI_CSI0_D_ATA3_N | | MIPI_CSI0_D_ATA1_N | | MIPI_CSI0_CLK_N | | MIPI_CSI0_D_ATA0_N | | MIPI_CSI0_D_ATA2_N | | CS1_D00 | | SCU_BOOT_MODE1 | | SCU_GPIO0_0_1 | | PMIC_I2C_SCL | | JTAG_TDI | | |
| AD | | VSS_MAIN | | VSS_MAIN | | VSS_MAIN | | VDD_QSPI0A_1P8_3P3 | | QSPI0A_SS1_B | | MIPI_CSI0_D_ATA3_P | | MIPI_CSI0_D_ATA1_P | | MIPI_CSI0_CLK_P | | MIPI_CSI0_D_ATA0_P | | MIPI_CSI0_D_ATA2_P | | CS1_D02 | | VSS_MAIN | | SCU_BOOT_MODE0 | | POR_B | | | |
| AE | QSPI0B_DAT_A1 | | QSPI0B_DAT_A3 | | VDD_QSPI0B_1P8_3P3 | | QSPI0B_SS0_B | | VSS_MAIN | | VSS_MAIN | | VSS_MAIN | | VSS_MAIN | | VSS_MAIN | | VSS_MAIN | | VSS_MAIN | | ANA_TEST_OUT_P | | SCU_BOOT_MODE2 | | VSS_MAIN | | PMIC_I2C_SDA | | |
| AF | | QSPI0B_DAT_A2 | | QSPI0B_DQS | | QSPI0B_SS1_B | | MIPI_DSIO_D_ATA0_N | | MIPI_DSIO_D_ATA1_N | | MIPI_DSIO_D_ATA3_N | | MIPI_DSIO_CLK_N | | MIPI_DSIO_D_ATA2_N | | MIPI_CSI0_M_CLK_OUT | | CS1_VSYNC | | VDD_CSI_1P8_3P3 | | ANA_TEST_OUT_N | | RTC_XTALO | | XTALO | | | |
| AG | VSS_MAIN | | QSPI0A_SCLK | | QSPI0A_DAT_A3 | | MIPI_DSIO_D_ATA2_N | | MIPI_DSIO_CLK_N | | MIPI_DSIO_D_ATA3_N | | MIPI_DSIO_D_ATA1_N | | MIPI_DSIO_D_ATA0_N | | VSS_MAIN | | CS1_PCLK | | CS1_D04 | | CS1_D03 | | VSS_MAIN | | VSS_SCU_XTAL | | VSS_SCU_XTAL | | |
| AH | | QSPI0B_SCLK | | QSPI0A_DAT_A1 | | VSS_MAIN | | MIPI_DSIO_D_ATA0_P | | MIPI_DSIO_D_ATA1_P | | MIPI_DSIO_D_ATA3_P | | MIPI_DSIO_CLK_P | | MIPI_DSIO_D_ATA2_P | | CS1_RESET | | CS1_HSYNC | | CS1_D07 | | CS1_D01 | | RTC_XTALI | | XTALI | | | |
| AJ | | | VSS_MAIN | | QSPI0A_DAT_A0 | | MIPI_DSIO_D_ATA2_P | | MIPI_DSIO_CLK_P | | MIPI_DSIO_D_ATA3_P | | MIPI_DSIO_D_ATA1_P | | MIPI_DSIO_D_ATA0_P | | CS1_EN | | CS1_MCLK | | CS1_D06 | | CS1_D05 | | ON_OFF_BUTTONON | | VSS_SCU_XTAL | | | | |

i.MX8QuadXPlusand8DualXPlusDualXAutomotiveandInfotainmentApplicationsProcessors,Rev.3,05/2020

6.2.3 17 x 17 mm power supplies and functional contact assignments

The following table shows the power supplies contact assignments for the 17 x 17 mm package.

Table 127. 17 x 17 mm power supplies contact assignments

| Power rail | Ball reference |
|-------------------------------|---|
| VDD_A35 | V12,V14,V16,W13,W15,W17 |
| VDD_ADC_1P8 | P22 |
| VDD_ADC_DIG_1P8 | T26 |
| VDD_ANA0_1P8 | K10 |
| VDD_ANA1_1P8 | W21 |
| VDD_CAN_UART_1P8_3P3 | U21 |
| VDD_CSI_1P8_3P3 | AF22 |
| VDD_DDR_PLL_1P8 | W7 |
| VDD_DDR_VDDQ | AA9,AB8,K8,M8,N9,P8,T8,U9,V8,Y8 |
| VDD_EMMC0_1P8_3P3 | D18 |
| VDD_EMMC0_VSELECT_1P8_3P3 | C19 |
| VDD_ENET_MDIO_1P8_3P3 | F26 |
| VDD_ENET0_1P8_2P5_3P3 | E21 |
| VDD_ENET0_VSELECT_1P8_2P5_3P3 | D20 |
| VDD_ESAI_SPDIF_1P8_2P5_3P3 | K26 |
| VDD_GPU | K20,L17,L19,M18,N19,P20,R17,T18 |
| VDD_MAIN | AA11,AA19,K16,L13,L21,M10,M14,N11,N15,P12,P16,R13,R21,T10,T14,U11,U15, U19,V20,Y10,Y14,Y18 |
| VDD_MIPI_1P0 | AA15,AB16 |
| VDD_MIPI_1P8 | AA13,AB14 |
| VDD_MIPI_CSI_DIG_1P8 | AB18 |
| VDD_PCIE_1P8 | J11 |
| VDD_PCIE_DIG_1P8_3P3 | J9 |
| VDD_PCIE_LDO_1P0_CAP | K12 |
| VDD_QSPI0A_1P8_3P3 | AD8 |
| VDD_QSPI0B_1P8_3P3 | AE5 |
| VDD_SNV5_4P2 | Y26 |
| VDD_SNV5_LDO_1P8_CAP | AB26 |
| VDD_SPI_MCLK_UART_1P8_3P3 | L27 |
| VDD_TMPR_CSI_1P8_3P3 | AA21 |

Table 127. 17 x 17 mm power supplies contact assignments (continued)

| Power rail | Ball reference |
|-------------------------|--|
| VDD_USB_1P8 | K14 |
| VDD_USB_3P3 | D12 |
| VDD_USB_SS3_LDO_1P0_CAP | D16 |
| VSS_MAIN | A3,A27,C1,C3,C5,C7,C9,C11,C15,C17,C29,E17,F2,F4,F6,F8,H26,J1,J3,J5,J7,J13,K18,L9,L11,L15,L29,M2,M4,M6,M12,M16,M20,M24,M26,N13,N17,N21,P10,P14,P18,R1,R3,R5,R7,R9,R11,R15,R19,R23,R25,R27,R29,T12,T16,T20,U13,U17,V2,V4,V6,V10,V18,V24,W9,W11,W19,Y12,Y16,Y20,AA1,AA3,AA5,AA7,AA17,AA27,AD2,AD4,AD6,AD24,AE9,AE11,AE13,AE15,AE17,AE19,AE21,AE27,AG1,AG17,AG25,AH6,AJ3 |
| VSS_SCU_XTAL | AG27,AG29,AJ27 |

Package information and contact assignments

The following table shows functional contact assignments for the 17 x 17 mm package.

Table 128. 17 x 17 mm functional contact assignments

| Ball | Ball Name | Power Domain | Ball Type ¹ | Reset Condition ² | | | |
|------|----------------|----------------------|------------------------|------------------------------|--------------------|-------------------|--------------|
| | | | | Default Mode | Default Function | Default Direction | Default Pull |
| P24 | ADC_IN0 | VDD_ADC_DIG_1P8 | GPIO | ALT0 | ADMA.ADC.IN0 | INPUT | PD(50K) |
| N23 | ADC_IN1 | VDD_ADC_DIG_1P8 | GPIO | ALT0 | ADMA.ADC.IN1 | INPUT | PD(50K) |
| N27 | ADC_IN2 | VDD_ADC_DIG_1P8 | GPIO | ALT0 | ADMA.ADC.IN2 | INPUT | PD(50K) |
| N25 | ADC_IN3 | VDD_ADC_DIG_1P8 | GPIO | ALT0 | ADMA.ADC.IN3 | INPUT | PD(50K) |
| P28 | ADC_IN4 | VDD_ADC_DIG_1P8 | GPIO | ALT0 | ADMA.ADC.IN4 | INPUT | PD(50K) |
| P26 | ADC_IN5 | VDD_ADC_DIG_1P8 | GPIO | ALT0 | ADMA.ADC.IN5 | INPUT | PD(50K) |
| M28 | ADC_VREFH | VDD_ADC_1P8 | ANA | | ADC_VREFH | | |
| N29 | ADC_VREFL | VDD_ADC_1P8 | ANA | | ADC_VREFL | | |
| AF24 | ANA_TEST_OUT_N | VDD_SCU_ANA_1P8 | ANA | | SCU.DSC.TEST_OUT_N | | |
| AE23 | ANA_TEST_OUT_P | VDD_SCU_ANA_1P8 | ANA | | SCU.DSC.TEST_OUT_P | | |
| AC21 | CSI_D00 | VDD_TMPR_CSI_1P8_3P3 | GPIO | ALT0 | CI_PI.CSI_D02 | INPUT | PD(50K) |
| AH24 | CSI_D01 | VDD_TMPR_CSI_1P8_3P3 | GPIO | ALT0 | CI_PI.CSI_D03 | INPUT | PD(50K) |
| AD22 | CSI_D02 | VDD_TMPR_CSI_1P8_3P3 | GPIO | ALT0 | CI_PI.CSI_D04 | INPUT | PD(50K) |
| AG23 | CSI_D03 | VDD_TMPR_CSI_1P8_3P3 | GPIO | ALT0 | CI_PI.CSI_D05 | INPUT | PD(50K) |
| AG21 | CSI_D04 | VDD_TMPR_CSI_1P8_3P3 | GPIO | ALT0 | CI_PI.CSI_D06 | INPUT | PD(50K) |
| AJ23 | CSI_D05 | VDD_TMPR_CSI_1P8_3P3 | GPIO | ALT0 | CI_PI.CSI_D07 | INPUT | PD(50K) |
| AJ21 | CSI_D06 | VDD_TMPR_CSI_1P8_3P3 | GPIO | ALT0 | CI_PI.CSI_D08 | INPUT | PD(50K) |
| AH22 | CSI_D07 | VDD_TMPR_CSI_1P8_3P3 | GPIO | ALT0 | CI_PI.CSI_D09 | INPUT | PD(50K) |
| AH20 | CSI_HSYNC | VDD_TMPR_CSI_1P8_3P3 | GPIO | ALT0 | CI_PI.CSI_HSYNC | INPUT | PD(50K) |
| AF20 | CSI_VSYNC | VDD_TMPR_CSI_1P8_3P3 | GPIO | ALT0 | CI_PI.CSI_VSYNC | INPUT | PD(50K) |
| AJ17 | CSI_EN | VDD_CSI_1P8_3P3 | GPIO | ALT0 | CI_PI.CSI_EN | INPUT | PD(50K) |
| AJ19 | CSI_MCLK | VDD_CSI_1P8_3P3 | GPIO | ALT0 | CI_PI.CSI_MCLK | INPUT | PD(50K) |
| AG19 | CSI_PCLK | VDD_CSI_1P8_3P3 | GPIO | ALT4 | LSIO.GPIO3.IO00 | INPUT | PD(50K) |
| AH18 | CSI_RESET | VDD_CSI_1P8_3P3 | GPIO | ALT0 | CI_PI.CSI_RESET | INPUT | PD(50K) |
| W5 | DDR_ATO | VDD_DDR_VDDQ | DDR | | DRC.ATO | | |
| G3 | DDR_CK0_N | VDD_DDR_VDDQ | DDR | | DRC.CK0_N | | |
| H2 | DDR_CK0_P | VDD_DDR_VDDQ | DDR | | DRC.CK0_P | | |
| B8 | DDR_CK1_N | VDD_DDR_VDDQ | DDR | | DRC.CK1_N | | |
| A7 | DDR_CK1_P | VDD_DDR_VDDQ | DDR | | DRC.CK1_P | | |
| G5 | DDR_DCF00 | VDD_DDR_VDDQ | DDR | | DRC.DCF00 | | |
| B2 | DDR_DCF01 | VDD_DDR_VDDQ | DDR | | DRC.DCF01 | | |

Table 128. 17 x 17 mm functional contact assignments (continued)

| Ball | Ball Name | Power Domain | Ball Type ¹ | Reset Condition ² | | | |
|------|-----------|--------------|------------------------|------------------------------|------------------|-------------------|--------------|
| | | | | Default Mode | Default Function | Default Direction | Default Pull |
| E3 | DDR_DCF03 | VDD_DDR_VDDQ | DDR | | DRC.DCF03 | | |
| K6 | DDR_DCF04 | VDD_DDR_VDDQ | DDR | | DRC.DCF04 | | |
| D4 | DDR_DCF05 | VDD_DDR_VDDQ | DDR | | DRC.DCF05 | | |
| B4 | DDR_DCF07 | VDD_DDR_VDDQ | DDR | | DRC.DCF07 | | |
| K2 | DDR_DCF08 | VDD_DDR_VDDQ | DDR | | DRC.DCF08 | | |
| L3 | DDR_DCF09 | VDD_DDR_VDDQ | DDR | | DRC.DCF09 | | |
| G1 | DDR_DCF10 | VDD_DDR_VDDQ | DDR | | DRC.DCF10 | | |
| L1 | DDR_DCF11 | VDD_DDR_VDDQ | DDR | | DRC.DCF11 | | |
| D2 | DDR_DCF12 | VDD_DDR_VDDQ | DDR | | DRC.DCF12 | | |
| K4 | DDR_DCF14 | VDD_DDR_VDDQ | DDR | | DRC.DCF14 | | |
| E1 | DDR_DCF15 | VDD_DDR_VDDQ | DDR | | DRC.DCF15 | | |
| L7 | DDR_DCF16 | VDD_DDR_VDDQ | DDR | | DRC.DCF16 | | |
| B6 | DDR_DCF17 | VDD_DDR_VDDQ | DDR | | DRC.DCF17 | | |
| A5 | DDR_DCF18 | VDD_DDR_VDDQ | DDR | | DRC.DCF18 | | |
| H6 | DDR_DCF19 | VDD_DDR_VDDQ | DDR | | DRC.DCF19 | | |
| D6 | DDR_DCF20 | VDD_DDR_VDDQ | DDR | | DRC.DCF20 | | |
| B10 | DDR_DCF21 | VDD_DDR_VDDQ | DDR | | DRC.DCF21 | | |
| E5 | DDR_DCF22 | VDD_DDR_VDDQ | DDR | | DRC.DCF22 | | |
| L5 | DDR_DCF23 | VDD_DDR_VDDQ | DDR | | DRC.DCF23 | | |
| H4 | DDR_DCF24 | VDD_DDR_VDDQ | DDR | | DRC.DCF24 | | |
| H10 | DDR_DCF25 | VDD_DDR_VDDQ | DDR | | DRC.DCF25 | | |
| A9 | DDR_DCF26 | VDD_DDR_VDDQ | DDR | | DRC.DCF26 | | |
| E9 | DDR_DCF27 | VDD_DDR_VDDQ | DDR | | DRC.DCF27 | | |
| D10 | DDR_DCF28 | VDD_DDR_VDDQ | DDR | | DRC.DCF28 | | |
| D8 | DDR_DCF29 | VDD_DDR_VDDQ | DDR | | DRC.DCF29 | | |
| H8 | DDR_DCF30 | VDD_DDR_VDDQ | DDR | | DRC.DCF30 | | |
| G9 | DDR_DCF31 | VDD_DDR_VDDQ | DDR | | DRC.DCF31 | | |
| E7 | DDR_DCF32 | VDD_DDR_VDDQ | DDR | | DRC.DCF32 | | |
| G7 | DDR_DCF33 | VDD_DDR_VDDQ | DDR | | DRC.DCF33 | | |
| W1 | DDR_DM0 | VDD_DDR_VDDQ | DDR | | DRC.DM0 | | |
| T6 | DDR_DM1 | VDD_DDR_VDDQ | DDR | | DRC.DM1 | | |
| N3 | DDR_DQ00 | VDD_DDR_VDDQ | DDR | | DRC.DQ00 | | |
| P2 | DDR_DQ01 | VDD_DDR_VDDQ | DDR | | DRC.DQ01 | | |

Table 128. 17 x 17 mm functional contact assignments (continued)

| Ball | Ball Name | Power Domain | Ball Type ¹ | Reset Condition ² | | | |
|------|---------------|---------------------------|------------------------|------------------------------|------------------|-------------------|--------------|
| | | | | Default Mode | Default Function | Default Direction | Default Pull |
| N1 | DDR_DQ02 | VDD_DDR_VDDQ | DDR | | DRC.DQ02 | | |
| T2 | DDR_DQ03 | VDD_DDR_VDDQ | DDR | | DRC.DQ03 | | |
| Y2 | DDR_DQ04 | VDD_DDR_VDDQ | DDR | | DRC.DQ04 | | |
| AB2 | DDR_DQ05 | VDD_DDR_VDDQ | DDR | | DRC.DQ05 | | |
| AC1 | DDR_DQ06 | VDD_DDR_VDDQ | DDR | | DRC.DQ06 | | |
| AC3 | DDR_DQ07 | VDD_DDR_VDDQ | DDR | | DRC.DQ07 | | |
| Y4 | DDR_DQ08 | VDD_DDR_VDDQ | DDR | | DRC.DQ08 | | |
| AC5 | DDR_DQ09 | VDD_DDR_VDDQ | DDR | | DRC.DQ09 | | |
| W3 | DDR_DQ10 | VDD_DDR_VDDQ | DDR | | DRC.DQ10 | | |
| AB4 | DDR_DQ11 | VDD_DDR_VDDQ | DDR | | DRC.DQ11 | | |
| P4 | DDR_DQ12 | VDD_DDR_VDDQ | DDR | | DRC.DQ12 | | |
| N5 | DDR_DQ13 | VDD_DDR_VDDQ | DDR | | DRC.DQ13 | | |
| P6 | DDR_DQ14 | VDD_DDR_VDDQ | DDR | | DRC.DQ14 | | |
| N7 | DDR_DQ15 | VDD_DDR_VDDQ | DDR | | DRC.DQ15 | | |
| U1 | DDR_DQS0_N | VDD_DDR_VDDQ | DDR | | DRC.DQS0_N | | |
| U3 | DDR_DQS0_P | VDD_DDR_VDDQ | DDR | | DRC.DQS0_P | | |
| T4 | DDR_DQS1_N | VDD_DDR_VDDQ | DDR | | DRC.DQS1_N | | |
| U5 | DDR_DQS1_P | VDD_DDR_VDDQ | DDR | | DRC.DQS1_P | | |
| U7 | DDR.DTO0 | VDD_DDR_VDDQ | DDR | | DRC.DTO0 | | |
| AB6 | DDR.DTO1 | VDD_DDR_VDDQ | DDR | | DRC.DTO1 | | |
| Y6 | DDR_VREF | VDD_DDR_VDDQ | DDR | | DRC.VREF0 | | |
| F10 | DDR_ZQ | VDD_DDR_VDDQ | DDR | | DRC.ZQ | | |
| F14 | EMMC0_CLK | VDD_EMMC0_1P8_3P3 | FASTD | ALT4 | LSIO.GPIO4.IO07 | INPUT | PD(50K) |
| E13 | EMMC0_CMD | VDD_EMMC0_1P8_3P3 | FASTD | ALT0 | CONN.EMMC0.CMD | INPUT | PD(50K) |
| A21 | EMMC0_DATA0 | VDD_EMMC0_1P8_3P3 | FASTD | ALT0 | CONN.EMMC0.DATA0 | INPUT | PD(50K) |
| F18 | EMMC0_DATA1 | VDD_EMMC0_1P8_3P3 | FASTD | ALT0 | CONN.EMMC0.DATA1 | INPUT | PD(50K) |
| G15 | EMMC0_DATA2 | VDD_EMMC0_1P8_3P3 | FASTD | ALT0 | CONN.EMMC0.DATA2 | INPUT | PD(50K) |
| E19 | EMMC0_DATA3 | VDD_EMMC0_1P8_3P3 | FASTD | ALT0 | CONN.EMMC0.DATA3 | INPUT | PD(50K) |
| G17 | EMMC0_DATA4 | VDD_EMMC0_VSELECT_1P8_3P3 | FASTD | ALT0 | CONN.EMMC0.DATA4 | INPUT | PD(50K) |
| F16 | EMMC0_DATA5 | VDD_EMMC0_VSELECT_1P8_3P3 | FASTD | ALT0 | CONN.EMMC0.DATA5 | INPUT | PD(50K) |
| E15 | EMMC0_DATA6 | VDD_EMMC0_VSELECT_1P8_3P3 | FASTD | ALT0 | CONN.EMMC0.DATA6 | INPUT | PD(50K) |
| H16 | EMMC0_DATA7 | VDD_EMMC0_VSELECT_1P8_3P3 | FASTD | ALT0 | CONN.EMMC0.DATA7 | INPUT | PD(50K) |
| B20 | EMMC0_RESET_B | VDD_EMMC0_VSELECT_1P8_3P3 | GPIO | ALT4 | LSIO.GPIO4.IO18 | INPUT | PU(50K) |

Table 128. 17 x 17 mm functional contact assignments (continued)

| Ball | Ball Name | Power Domain | Ball Type ¹ | Reset Condition ² | | | |
|------|-----------------------|-------------------------------|------------------------|------------------------------|-------------------------|-------------------|--------------|
| | | | | Default Mode | Default Function | Default Direction | Default Pull |
| J17 | EMMC0_STROBE | VDD_EMMC0_VSELECT_1P8_3P3 | FASTD | ALT0 | CONN.EMMC0.STROBE | INPUT | PD(50K) |
| A25 | ENET0_MDC | VDD_ENET_MDIO_1P8_3P3 | GPIO | ALT4 | LSIO.GPIO5.IO11 | INPUT | PD(50K) |
| J21 | ENET0_MDIO | VDD_ENET_MDIO_1P8_3P3 | GPIO | ALT0 | CONN.ENET0.MDIO | INPUT | PU(50K) |
| F22 | ENET0_REFCLK_125M_25M | VDD_ENET_MDIO_1P8_3P3 | GPIO | ALT4 | LSIO.GPIO5.IO09 | INPUT | PD(50K) |
| H20 | ENET0_RGMII_RX_CTL | VDD_ENET0_1P8_2P5_3P3 | FASTD | ALT0 | CONN.ENET0.RGMII_RX_CTL | INPUT | PD(50K) |
| A23 | ENET0_RGMII_RXC | VDD_ENET0_1P8_2P5_3P3 | FASTD | ALT0 | CONN.ENET0.RGMII_RXC | INPUT | PD(50K) |
| C23 | ENET0_RGMII_RXD0 | VDD_ENET0_1P8_2P5_3P3 | FASTD | ALT0 | CONN.ENET0.RGMII_RXD0 | INPUT | PD(50K) |
| D22 | ENET0_RGMII_RXD1 | VDD_ENET0_1P8_2P5_3P3 | FASTD | ALT0 | CONN.ENET0.RGMII_RXD1 | INPUT | PD(50K) |
| G21 | ENET0_RGMII_RXD2 | VDD_ENET0_1P8_2P5_3P3 | FASTD | ALT0 | CONN.ENET0.RGMII_RXD2 | INPUT | PD(50K) |
| B24 | ENET0_RGMII_RXD3 | VDD_ENET0_1P8_2P5_3P3 | FASTD | ALT0 | CONN.ENET0.RGMII_RXD3 | INPUT | PD(50K) |
| H18 | ENET0_RGMII_TX_CTL | VDD_ENET0_VSELECT_1P8_2P5_3P3 | FASTD | ALT4 | LSIO.GPIO4.IO30 | INPUT | PD(50K) |
| G19 | ENET0_RGMII_TXC | VDD_ENET0_VSELECT_1P8_2P5_3P3 | FASTD | ALT4 | LSIO.GPIO4.IO29 | INPUT | PD(50K) |
| F20 | ENET0_RGMII_TXD0 | VDD_ENET0_VSELECT_1P8_2P5_3P3 | FASTD | ALT4 | LSIO.GPIO4.IO31 | INPUT | PD(50K) |
| C21 | ENET0_RGMII_TXD1 | VDD_ENET0_VSELECT_1P8_2P5_3P3 | FASTD | ALT4 | LSIO.GPIO5.IO00 | INPUT | PD(50K) |
| J19 | ENET0_RGMII_TXD2 | VDD_ENET0_VSELECT_1P8_2P5_3P3 | FASTD | ALT4 | LSIO.GPIO5.IO01 | INPUT | PD(50K) |
| B22 | ENET0_RGMII_TXD3 | VDD_ENET0_VSELECT_1P8_2P5_3P3 | FASTD | ALT4 | LSIO.GPIO5.IO02 | INPUT | PD(50K) |
| B26 | ESAI0_FSR | VDD_ESAI_SPDIF_1P8_2P5_3P3 | GPIO | ALT0 | ADMA.ESAI0.FSR | INPUT | PD(50K) |
| E23 | ESAI0_FST | VDD_ESAI_SPDIF_1P8_2P5_3P3 | GPIO | ALT0 | ADMA.ESAI0.FST | INPUT | PD(50K) |
| H22 | ESAI0_SCKR | VDD_ESAI_SPDIF_1P8_2P5_3P3 | GPIO | ALT0 | ADMA.ESAI0.SCKR | INPUT | PD(50K) |
| C25 | ESAI0_SCKT | VDD_ESAI_SPDIF_1P8_2P5_3P3 | GPIO | ALT0 | ADMA.ESAI0.SCKT | INPUT | PD(50K) |
| G23 | ESAI0_TX0 | VDD_ESAI_SPDIF_1P8_2P5_3P3 | GPIO | ALT0 | ADMA.ESAI0.TX0 | INPUT | PD(50K) |
| E25 | ESAI0_TX1 | VDD_ESAI_SPDIF_1P8_2P5_3P3 | GPIO | ALT0 | ADMA.ESAI0.TX1 | INPUT | PD(50K) |
| C27 | ESAI0_TX2_RX3 | VDD_ESAI_SPDIF_1P8_2P5_3P3 | GPIO | ALT0 | ADMA.ESAI0.TX2_RX3 | INPUT | PD(50K) |
| D24 | ESAI0_TX3_RX2 | VDD_ESAI_SPDIF_1P8_2P5_3P3 | GPIO | ALT0 | ADMA.ESAI0.TX3_RX2 | INPUT | PD(50K) |
| B28 | ESAI0_TX4_RX1 | VDD_ESAI_SPDIF_1P8_2P5_3P3 | GPIO | ALT0 | ADMA.ESAI0.TX4_RX1 | INPUT | PD(50K) |
| K22 | ESAI0_TX5_RX0 | VDD_ESAI_SPDIF_1P8_2P5_3P3 | GPIO | ALT0 | ADMA.ESAI0.TX5_RX0 | INPUT | PD(50K) |
| T22 | FLEXCAN0_RX | VDD_CAN_UART_1P8_3P3 | GPIO | ALT0 | ADMA.FLEXCAN0.RX | INPUT | PD(50K) |
| U25 | FLEXCAN0_TX | VDD_CAN_UART_1P8_3P3 | GPIO | ALT4 | LSIO.GPIO1.IO16 | INPUT | PD(50K) |
| T24 | FLEXCAN1_RX | VDD_CAN_UART_1P8_3P3 | GPIO | ALT0 | ADMA.FLEXCAN1.RX | INPUT | PD(50K) |

Table 128. 17 x 17 mm functional contact assignments (continued)

| Ball | Ball Name | Power Domain | Ball Type ¹ | Reset Condition ² | | | |
|------|--------------------|-----------------------------------|------------------------|------------------------------|--------------------|-------------------|--------------|
| | | | | Default Mode | Default Function | Default Direction | Default Pull |
| U29 | FLEXCAN1_TX | VDD_CAN_UART_1P8_3P3 | GPIO | ALT4 | LSIO.GPIO1.IO18 | INPUT | PD(50K) |
| T28 | FLEXCAN2_RX | VDD_CAN_UART_1P8_3P3 | GPIO | ALT0 | ADMA.FLEXCAN2.RX | INPUT | PD(50K) |
| U27 | FLEXCAN2_TX | VDD_CAN_UART_1P8_3P3 | GPIO | ALT4 | LSIO.GPIO1.IO20 | INPUT | PD(50K) |
| AA29 | JTAG_TCK | VDD_ANA1_1P8 | TEST | ALT0 | SCU.JTAG.TCK | INPUT | PD(50K) |
| AC29 | JTAG_TDI | VDD_ANA1_1P8 | TEST | ALT0 | SCU.JTAG.TDI | INPUT | PU(50K) |
| Y24 | JTAG_TDO | VDD_ANA1_1P8 | TEST | ALT0 | SCU.JTAG.TDO | OUTPUT | HiZ |
| W23 | JTAG_TMS | VDD_ANA1_1P8 | TEST | ALT0 | SCU.JTAG.TMS | INPUT | PU(50K) |
| L23 | MCLK_IN0 | VDD_SPI_MCLK_UART_1P8_3P3 | GPIO | ALT0 | ADMA.ACM.MCLK_IN0 | INPUT | PD(50K) |
| M22 | MCLK_IN1 | VDD_SPI_MCLK_UART_1P8_3P3 | GPIO | ALT0 | ADMA.ACM.MCLK_IN1 | INPUT | PD(50K) |
| K24 | MCLK_OUT0 | VDD_SPI_MCLK_UART_1P8_3P3 | GPIO | ALT4 | LSIO.GPIO0.IO20 | INPUT | PD(50K) |
| AC15 | MIPI_CSI0_CLK_N | VDD_MIPI_CSI0_1P8 | CSI | | MIPI_CSI0.CKN | | |
| AD16 | MIPI_CSI0_CLK_P | VDD_MIPI_CSI0_1P8 | CSI | | MIPI_CSI0.CKP | | |
| AC17 | MIPI_CSI0_DATA0_N | VDD_MIPI_CSI0_1P8 | CSI | | MIPI_CSI0.DN0 | | |
| AD18 | MIPI_CSI0_DATA0_P | VDD_MIPI_CSI0_1P8 | CSI | | MIPI_CSI0.DP0 | | |
| AC13 | MIPI_CSI0_DATA1_N | VDD_MIPI_CSI0_1P8 | CSI | | MIPI_CSI0.DN1 | | |
| AD14 | MIPI_CSI0_DATA1_P | VDD_MIPI_CSI0_1P8 | CSI | | MIPI_CSI0.DP1 | | |
| AC19 | MIPI_CSI0_DATA2_N | VDD_MIPI_CSI0_1P8 | CSI | | MIPI_CSI0.DN2 | | |
| AD20 | MIPI_CSI0_DATA2_P | VDD_MIPI_CSI0_1P8 | CSI | | MIPI_CSI0.DP2 | | |
| AC11 | MIPI_CSI0_DATA3_N | VDD_MIPI_CSI0_1P8 | CSI | | MIPI_CSI0.DN3 | | |
| AD12 | MIPI_CSI0_DATA3_P | VDD_MIPI_CSI0_1P8 | CSI | | MIPI_CSI0.DP3 | | |
| AF18 | MIPI_CSI0_MCLK_OUT | VDD_MIPI_CSI_DIG_1P8 | GPIO | ALT4 | LSIO.GPIO3.IO04 | INPUT | PD(50K) |
| AF14 | MIPI_DSI0_CLK_N | VDD_MIPI_DSI0_1P8 | DSI | | MIPI_DSI0.CKN | | |
| AH14 | MIPI_DSI0_CLK_P | VDD_MIPI_DSI0_1P8 | DSI | | MIPI_DSI0.CKP | | |
| AG15 | MIPI_DSI0_DATA0_N | VDD_MIPI_DSI0_1P8 | DSI | | MIPI_DSI0.DN0 | | |
| AJ15 | MIPI_DSI0_DATA0_P | VDD_MIPI_DSI0_1P8 | DSI | | MIPI_DSI0.DP0 | | |
| AG13 | MIPI_DSI0_DATA1_N | VDD_MIPI_DSI0_1P8 | DSI | | MIPI_DSI0.DN1 | | |
| AJ13 | MIPI_DSI0_DATA1_P | VDD_MIPI_DSI0_1P8 | DSI | | MIPI_DSI0.DP1 | | |
| AF16 | MIPI_DSI0_DATA2_N | VDD_MIPI_DSI0_1P8 | DSI | | MIPI_DSI0.DN2 | | |
| AH16 | MIPI_DSI0_DATA2_P | VDD_MIPI_DSI0_1P8 | DSI | | MIPI_DSI0.DP2 | | |
| AF12 | MIPI_DSI0_DATA3_N | VDD_MIPI_DSI0_1P8 | DSI | | MIPI_DSI0.DN3 | | |
| AH12 | MIPI_DSI0_DATA3_P | VDD_MIPI_DSI0_1P8 | DSI | | MIPI_DSI0.DP3 | | |
| W27 | MIPI_DSI0_I2C0_SCL | VDD_CAN_UART_1P8_3P3 ³ | GPIO | ALT0 | MIPI_DSI0.I2C0_SCL | INPUT | PU(50K) |
| V22 | MIPI_DSI0_I2C0_SDA | VDD_CAN_UART_1P8_3P3 ³ | GPIO | ALT0 | MIPI_DSI0.I2C0_SDA | INPUT | PU(50K) |

Table 128. 17 x 17 mm functional contact assignments (continued)

| Ball | Ball Name | Power Domain | Ball Type ¹ | Reset Condition ² | | | |
|------|--------------------------|-----------------------------------|------------------------|------------------------------|--------------------------------|-------------------|--------------|
| | | | | Default Mode | Default Function | Default Direction | Default Pull |
| AG9 | MIPI_DSI1_CLK_N | VDD_MIPI_DSI1_1P8 | DSI | | MIPI_DSI1.CKN | | |
| AJ9 | MIPI_DSI1_CLK_P | VDD_MIPI_DSI1_1P8 | DSI | | MIPI_DSI1.CKP | | |
| AF8 | MIPI_DSI1_DATA0_N | VDD_MIPI_DSI1_1P8 | DSI | | MIPI_DSI1.DN0 | | |
| AH8 | MIPI_DSI1_DATA0_P | VDD_MIPI_DSI1_1P8 | DSI | | MIPI_DSI1.DP0 | | |
| AF10 | MIPI_DSI1_DATA1_N | VDD_MIPI_DSI1_1P8 | DSI | | MIPI_DSI1.DN1 | | |
| AH10 | MIPI_DSI1_DATA1_P | VDD_MIPI_DSI1_1P8 | DSI | | MIPI_DSI1.DP1 | | |
| AG7 | MIPI_DSI1_DATA2_N | VDD_MIPI_DSI1_1P8 | DSI | | MIPI_DSI1.DN2 | | |
| AJ7 | MIPI_DSI1_DATA2_P | VDD_MIPI_DSI1_1P8 | DSI | | MIPI_DSI1.DP2 | | |
| AG11 | MIPI_DSI1_DATA3_N | VDD_MIPI_DSI1_1P8 | DSI | | MIPI_DSI1.DN3 | | |
| AJ11 | MIPI_DSI1_DATA3_P | VDD_MIPI_DSI1_1P8 | DSI | | MIPI_DSI1.DP3 | | |
| Y28 | MIPI_DSI1_I2C0_SCL | VDD_CAN_UART_1P8_3P3 ³ | GPIO | ALT0 | MIPI_DSI1.I2C0.SCL | INPUT | PU(50K) |
| W25 | MIPI_DSI1_I2C0_SDA | VDD_CAN_UART_1P8_3P3 ³ | GPIO | ALT0 | MIPI_DSI1.I2C0.SDA | INPUT | PU(50K) |
| AJ25 | ON_OFF_BUTTON | VDD_SNVLS_LDO_1P8_CAP | ANA | | SNVLS.ON_OFF_BUTTON | | |
| E11 | PCIE_CTRL0_CLKREQ_B | VDD_PCIE_DIG_1P8_3P3 | GPIO | ALT0 | HSIO.PCIE0.CLKREQ_B | INPUT | PD(50K) |
| A11 | PCIE_CTRL0_PERST_B | VDD_PCIE_DIG_1P8_3P3 | GPIO | ALT0 | HSIO.PCIE0.PERST_B | INPUT | PD(50K) |
| B14 | PCIE_CTRL0_WAKE_B | VDD_PCIE_DIG_1P8_3P3 | GPIO | ALT0 | HSIO.PCIE0.WAKE_B | INPUT | PU(50K) |
| F12 | PCIE_REF_QR | VDD_PCIE_1P8 | PCIE | | HSIO.PCIE_I0B.REF_QR | | |
| C13 | PCIE_REFCLK100M_N | VDD_PCIE_1P8 | PCIE | | HSIO.PCIE_I0B.EXT_REFCLK100M_N | | |
| D14 | PCIE_REFCLK100M_P | VDD_PCIE_1P8 | PCIE | | HSIO.PCIE_I0B.EXT_REFCLK100M_P | | |
| H12 | PCIE_REXT | VDD_PCIE0_1P0 | PCIE | | HSIO.PCIE.REXT | | |
| G11 | PCIE0_PHY_PLL_REF_RETURN | VDD_PCIE_LDO_1P0_CAP | PCIE | | HSIO.PCIE0.PLL_REF_RETURN | | |
| B16 | PCIE0_RX0_N | VDD_PCIE_LDO_1P0_CAP | PCIE | | HSIO.PCIE0.RX0_N | | |
| A15 | PCIE0_RX0_P | VDD_PCIE_LDO_1P0_CAP | PCIE | | HSIO.PCIE0.RX0_P | | |
| B12 | PCIE0_TX0_N | VDD_PCIE_LDO_1P0_CAP | PCIE | | HSIO.PCIE0.TX0_N | | |
| A13 | PCIE0_TX0_P | VDD_PCIE_LDO_1P0_CAP | PCIE | | HSIO.PCIE0.TX0_P | | |
| AC27 | PMIC_I2C_SCL | VDD_ANA1_1P8 | SCU | ALT0 | SCU.PMIC_I2C.SCL | INPUT | PU(50K) |
| AE29 | PMIC_I2C_SDA | VDD_ANA1_1P8 | SCU | ALT0 | SCU.PMIC_I2C.SDA | INPUT | PU(50K) |
| AA23 | PMIC_INT_B | VDD_ANA1_1P8 | SCU | ALT0 | SCU.DSC.PMIC_INT_B | INPUT | PU(50K) |
| AB20 | PMIC_ON_REQ | VDD_SNVLS_LDO_1P8_CAP | ANA | | SNVLS.PMIC_ON_REQ | | |
| AD28 | POR_B | VDD_ANA1_1P8 | SCU | ALT0 | SCU.DSC.POR_B | INPUT | PU(50K) |
| AJ5 | QSPI0A_DATA0 | VDD_QSPI0A_1P8_3P3 | FASTD | ALT0 | LSIO.QSPI0A.DATA0 | INPUT | PD(50K) |

Table 128. 17 x 17 mm functional contact assignments (continued)

| Ball | Ball Name | Power Domain | Ball Type ¹ | Reset Condition ² | | | |
|------|---------------------------|--|------------------------|------------------------------|----------------------|-------------------|--------------|
| | | | | Default Mode | Default Function | Default Direction | Default Pull |
| AH4 | QSPI0A_DATA1 | VDD_QSPI0A_1P8_3P3 | FASTD | ALT0 | LSIO.QSPI0A.DATA1 | INPUT | PD(50K) |
| AC9 | QSPI0A_DATA2 | VDD_QSPI0A_1P8_3P3 | FASTD | ALT0 | LSIO.QSPI0A.DATA2 | INPUT | PD(50K) |
| AG5 | QSPI0A_DATA3 | VDD_QSPI0A_1P8_3P3 | FASTD | ALT0 | LSIO.QSPI0A.DATA3 | INPUT | PD(50K) |
| AB10 | QSPI0A_DQS | VDD_QSPI0A_1P8_3P3 | FASTD | ALT0 | LSIO.QSPI0A.DQS | INPUT | PD(50K) |
| AG3 | QSPI0A_SCLK | VDD_QSPI0A_1P8_3P3 | FASTD | ALT4 | LSIO.GPIO3.IO16 | INPUT | PD(50K) |
| AB12 | QSPI0A_SS0_B | VDD_QSPI0A_1P8_3P3 | FASTD | ALT4 | LSIO.GPIO3.IO14 | INPUT | PU(50K) |
| AD10 | QSPI0A_SS1_B | VDD_QSPI0A_1P8_3P3 | FASTD | ALT4 | LSIO.GPIO3.IO15 | INPUT | PU(50K) |
| AC7 | QSPI0B_DATA0 | VDD_QSPI0B_1P8_3P3 | FASTD | ALT0 | LSIO.QSPI0B.DATA0 | INPUT | PD(50K) |
| AE1 | QSPI0B_DATA1 | VDD_QSPI0B_1P8_3P3 | FASTD | ALT0 | LSIO.QSPI0B.DATA1 | INPUT | PD(50K) |
| AF2 | QSPI0B_DATA2 | VDD_QSPI0B_1P8_3P3 | FASTD | ALT0 | LSIO.QSPI0B.DATA2 | INPUT | PD(50K) |
| AE3 | QSPI0B_DATA3 | VDD_QSPI0B_1P8_3P3 | FASTD | ALT0 | LSIO.QSPI0B.DATA3 | INPUT | PD(50K) |
| AF4 | QSPI0B_DQS | VDD_QSPI0B_1P8_3P3 | FASTD | ALT0 | LSIO.QSPI0B.DQS | INPUT | PD(50K) |
| AH2 | QSPI0B_SCLK | VDD_QSPI0B_1P8_3P3 | FASTD | ALT4 | LSIO.GPIO3.IO17 | INPUT | PD(50K) |
| AE7 | QSPI0B_SS0_B | VDD_QSPI0B_1P8_3P3 | FASTD | ALT4 | LSIO.GPIO3.IO23 | INPUT | PU(50K) |
| AF6 | QSPI0B_SS1_B | VDD_QSPI0B_1P8_3P3 | FASTD | ALT4 | LSIO.GPIO3.IO24 | INPUT | PU(50K) |
| AH26 | RTC_XTALI | VDD_SNVLS_LDO_1P8_CAP | ANA | | SNVLS.RTC_XTALI | | |
| AF26 | RTC_XTALO | VDD_SNVLS_LDO_1P8_CAP | ANA | | SNVLS.RTC_XTALO | | |
| AD26 | SCU_BOOT_MODE0 | VDD_ANA1_1P8 | SCU | ALT0 | SCU.DSC.BOOT_MODE0 | INPUT | PD(50K) |
| AC23 | SCU_BOOT_MODE1 | VDD_ANA1_1P8 | SCU | ALT0 | SCU.DSC.BOOT_MODE1 | INPUT | PD(50K) |
| AE25 | SCU_BOOT_MODE2 | VDD_ANA1_1P8 | SCU | ALT0 | SCU.DSC.BOOT_MODE2 | INPUT | PD(50K) |
| AB22 | SCU_BOOT_MODE3 | VDD_ANA1_1P8 | SCU | ALT0 | SCU.DSC.BOOT_MODE3 | INPUT | PD(50K) |
| Y22 | SCU_GPIO0_00 | VDD_ANA1_1P8 | GPIO | ALT0 | SCU.GPIO0.IO00 | INPUT | PD(50K) |
| AC25 | SCU_GPIO0_01 | VDD_ANA1_1P8 | GPIO | ALT0 | SCU.GPIO0.IO01 | INPUT | PU(50K) |
| AB24 | SCU_PMIC_STANDBY | VDD_ANA1_1P8 | SCU | ALT0 | SCU.DSC.PMIC_STANDBY | OUTPUT | Drive 0 |
| AB28 | SCU_WDOG_OUT ⁴ | VDD_ANA1_1P8 | SCU | ALT1 | SCU.WDOG0.WDOG_OUT | OUTPUT | PD(50K) |
| E27 | SPDIF0_EXT_CLK | VDD_ESAI_SPDIF_1P8_2P5_3P3 | GPIO | ALT0 | ADMA.SPDIF0.EXT_CLK | INPUT | PD(50K) |
| F24 | SPDIF0_RX | VDD_ESAI_SPDIF_1P8_2P5_3P3 | GPIO | ALT0 | ADMA.SPDIF0.RX | INPUT | PD(50K) |
| J23 | SPDIF0_TX | VDD_ESAI_SPDIF_1P8_2P5_3P3 | GPIO | ALT4 | LSIO.GPIO0.IO11 | INPUT | PD(50K) |
| H28 | SPI0_CS0 | VDD_SPI_MCLK_UART_1P8_3P3 ³ | GPIO | ALT0 | ADMA.SPI0.CS0 | INPUT | PD(50K) |
| K28 | SPI0_CS1 | VDD_SPI_MCLK_UART_1P8_3P3 ³ | GPIO | ALT0 | ADMA.SPI0.CS1 | INPUT | PD(50K) |
| L25 | SPI0_SCK | VDD_SPI_MCLK_UART_1P8_3P3 ³ | GPIO | ALT0 | ADMA.SPI0.SCK | INPUT | PD(50K) |
| J29 | SPI0_SDI | VDD_SPI_MCLK_UART_1P8_3P3 ³ | GPIO | ALT0 | ADMA.SPI0.SDI | INPUT | PD(50K) |
| J27 | SPI0_SDO | VDD_SPI_MCLK_UART_1P8_3P3 ³ | GPIO | ALT4 | LSIO.GPIO1.IO06 | INPUT | PD(50K) |

Table 128. 17 x 17 mm functional contact assignments (continued)

| Ball | Ball Name | Power Domain | Ball Type ¹ | Reset Condition ² | | | |
|------|------------------|---------------------------|------------------------|--------------------------------|--------------------------|-------------------|--------------|
| | | | | Default Mode | Default Function | Default Direction | Default Pull |
| D26 | SPI3_CS0 | VDD_SPI_MCLK_UART_1P8_3P3 | GPIO | ALT0 | ADMA.SPI3.CS0 | INPUT | PD(50K) |
| F28 | SPI3_CS1 | VDD_SPI_MCLK_UART_1P8_3P3 | GPIO | ALT0 | ADMA.SPI3.CS1 | INPUT | PD(50K) |
| D28 | SPI3_SCK | VDD_SPI_MCLK_UART_1P8_3P3 | GPIO | ALT0 | ADMA.SPI3.SCK | INPUT | PD(50K) |
| H24 | SPI3_SDI | VDD_SPI_MCLK_UART_1P8_3P3 | GPIO | ALT0 | ADMA.SPI3.SDI | INPUT | PD(50K) |
| G25 | SPI3_SDO | VDD_SPI_MCLK_UART_1P8_3P3 | GPIO | ALT4 | LSIO.GPIO0.IO14 | INPUT | PD(50K) |
| AA25 | TEST_MODE_SELECT | VDD_ANA1_1P8 | SCU | ALT0 | SCU.TCU.TEST_MODE_SELECT | INPUT | PD(50K) |
| V28 | UART0_RX | VDD_CAN_UART_1P8_3P3 | GPIO | ALT0 | ADMA.UART0.RX | INPUT | PD(50K) |
| U23 | UART0_TX | VDD_CAN_UART_1P8_3P3 | GPIO | ALT4 | LSIO.GPIO1.IO22 | INPUT | PD(50K) |
| G27 | UART1_CTS_B | VDD_SPI_MCLK_UART_1P8_3P3 | GPIO | ALT0 | ADMA.UART1.CTS_B | INPUT | PD(50K) |
| G29 | UART1_RTS_B | VDD_SPI_MCLK_UART_1P8_3P3 | GPIO | ALT4 | LSIO.GPT0.CLK | INPUT | PD(50K) |
| E29 | UART1_RX | VDD_SPI_MCLK_UART_1P8_3P3 | GPIO | ALT0 | ADMA.UART1.RX | INPUT | PD(50K) |
| J25 | UART1_TX | VDD_SPI_MCLK_UART_1P8_3P3 | GPIO | ALT4 | LSIO.GPIO0.IO21 | INPUT | PD(50K) |
| W29 | UART2_RX | VDD_CAN_UART_1P8_3P3 | GPIO | ALT0 | ADMA.UART2.RX | INPUT | PD(50K) |
| V26 | UART2_TX | VDD_CAN_UART_1P8_3P3 | GPIO | ALT4 | LSIO.GPIO1.IO23 | INPUT | PD(50K) |
| B18 | USB_OTG1_DN | VDD_USB_3P3 | OTG | | CONN.USB_OTG1.DN | | |
| A19 | USB_OTG1_DP | VDD_USB_3P3 | OTG | | CONN.USB_OTG1.DP | | |
| A17 | USB_OTG1_ID | VDD_USB_3P3 | OTG | | CONN.USB_OTG1.ID | | |
| J15 | USB_OTG1_VBUS | OTG | | CONN. USB_O TG1.VB US | | | |
| G13 | USB_SS3_TC1 | VDD_USB_3P3 | GPIO | ALT0 | ADMA.I2C1.SCL | INPUT | PD(50K) |
| H14 | USB_SS3_TC3 | VDD_USB_3P3 | GPIO | ALT0 | ADMA.I2C1.SDA | INPUT | PU(50K) |
| AH28 | XTALI | VDD_ANA1_1P8 | ANA | | SCU.DSC.XTALI | | |
| AF28 | XTALO | VDD_ANA1_1P8 | ANA | | SCU.DSC.XTALO | | |

¹ FASTD are GPIO balls configured for high speed operation using the FASTRZ control.

² Reset condition shown is before boot code execution. For pad changes after boot code execution, see the System Boot chapter of the device reference manual.

³ Power domain and associated IO grouping differs from 21 x 21 package.

⁴ SCU_WDOG_OUT was previously named JTAG_TRST_B; it has been renamed because its functionality has changed.

Package information and contact assignments

The following table shows the DDR 17 x 17 mm pin function.

Table 129. i.MX 8QXP 17 x 17 mm DRAM pin function

| Ball Name | Ball | LPDDR4 function | DDR3L function |
|-----------|------|-----------------|----------------|
| DDR_ATO | W5 | DDR_ATO | DDR_ATO |
| DDR_CK0_N | G3 | DDR_CK0_N | DDR_CK0_N |
| DDR_CK0_P | H2 | DDR_CK0_P | DDR_CK0_P |
| DDR_CK1_N | B8 | DDR_CK1_N | DDR_CK1_N |
| DDR_CK1_P | A7 | DDR_CK1_P | DDR_CK1_P |
| DDR_DCF00 | G5 | CA2_A | A5 |
| DDR_DCF01 | B2 | CA4_A | A6 |
| DDR_DCF03 | E3 | CA5_A | A7 |
| DDR_DCF04 | K6 | / | A8 |
| DDR_DCF05 | D4 | / | A9 |
| DDR_DCF07 | B4 | / | RAS# |
| DDR_DCF08 | K2 | CA3_A | A3 |
| DDR_DCF09 | L3 | ODT_CA_A | ODT |
| DDR_DCF10 | G1 | CS0_A | A1 |
| DDR_DCF11 | L1 | CA0_A | A0 |
| DDR_DCF12 | D2 | CS1_A | A2 |
| DDR_DCF14 | K4 | CKE0_A | / |
| DDR_DCF15 | E1 | CKE1_A | / |
| DDR_DCF16 | L7 | CA1_A | A4 |
| DDR_DCF17 | B6 | CA4_B | A12 |
| DDR_DCF18 | A5 | RESET_N | RESET_N |
| DDR_DCF19 | H6 | CA5_B | A14 |
| DDR_DCF20 | D6 | / | A15 |
| DDR_DCF21 | B10 | / | BA0 |
| DDR_DCF22 | E5 | / | BA1 |
| DDR_DCF23 | L5 | / | BA2 |
| DDR_DCF24 | H4 | / | CAS# |
| DDR_DCF25 | H10 | ODT_CA_B | ODT1 |
| DDR_DCF26 | A9 | CA3_B | A13 |
| DDR_DCF27 | E9 | CA0_B | A10 |
| DDR_DCF28 | D10 | CS0_B | CS_N[0] |

Table 129. i.MX 8QXP 17 x 17 mm DRAM pin function (continued)

| Ball Name | Ball | LPDDR4 function | DDR3L function |
|------------|------|-----------------|----------------|
| DDR_DCF29 | D8 | CS1_B | CS_N[1] |
| DDR_DCF30 | H8 | CKE0_B | CKE0 |
| DDR_DCF31 | G9 | CKE1_B | CKE1 |
| DDR_DCF32 | E7 | CA1_B | A11 |
| DDR_DCF33 | G7 | CA2_B | WE# |
| DDR_DM0 | W1 | DDR_DMI0 | DDR_DMI0 |
| DDR_DM1 | T6 | DDR_DMI1 | DDR_DMI1 |
| DDR_DQ00 | N3 | DDR_DQ00 | DDR_DQ00 |
| DDR_DQ01 | P2 | DDR_DQ01 | DDR_DQ01 |
| DDR_DQ02 | N1 | DDR_DQ02 | DDR_DQ02 |
| DDR_DQ03 | T2 | DDR_DQ03 | DDR_DQ03 |
| DDR_DQ04 | Y2 | DDR_DQ04 | DDR_DQ04 |
| DDR_DQ05 | AB2 | DDR_DQ05 | DDR_DQ05 |
| DDR_DQ06 | AC1 | DDR_DQ06 | DDR_DQ06 |
| DDR_DQ07 | AC3 | DDR_DQ07 | DDR_DQ07 |
| DDR_DQ08 | Y4 | DDR_DQ08 | DDR_DQ08 |
| DDR_DQ09 | AC5 | DDR_DQ09 | DDR_DQ09 |
| DDR_DQ10 | W3 | DDR_DQ10 | DDR_DQ10 |
| DDR_DQ11 | AB4 | DDR_DQ11 | DDR_DQ11 |
| DDR_DQ12 | P4 | DDR_DQ12 | DDR_DQ12 |
| DDR_DQ13 | N5 | DDR_DQ13 | DDR_DQ13 |
| DDR_DQ14 | P6 | DDR_DQ14 | DDR_DQ14 |
| DDR_DQ15 | N7 | DDR_DQ15 | DDR_DQ15 |
| DDR_DQS0_N | U1 | DDR_DQS0_N | DDR_DQS0_N |
| DDR_DQS0_P | U3 | DDR_DQS0_P | DDR_DQS0_P |
| DDR_DQS1_N | T4 | DDR_DQS1_N | DDR_DQS1_N |
| DDR_DQS1_P | U5 | DDR_DQS1_P | DDR_DQS1_P |
| DDR.DTO0 | U7 | DDR.DTO0 | DDR.DTO0 |
| DDR.DTO1 | AB6 | DDR.DTO1 | DDR.DTO1 |

7 Release Notes

This table provides release notes for the data sheet.

Table 130. Data sheet release notes

| Rev. Number | Date | Substantive Change(s) |
|-------------|---------|---|
| 3 | 05/2020 | • Added CAN/CAN-FD note in Table 1 , "i.MX 8QuadXPlus/8DualXPlus advanced features" |

How to Reach Us:

Home Page:

nxp.com

Web Support:

nxp.com/support

Information in this document is provided solely to enable system and software implementers to use NXP products. There are no express or implied copyright licenses granted hereunder to design or fabricate any integrated circuits based on the information in this document. NXP reserves the right to make changes without further notice to any products herein.

NXP makes no warranty, representation, or guarantee regarding the suitability of its products for any particular purpose, nor does NXP assume any liability arising out of the application or use of any product or circuit, and specifically disclaims any and all liability, including without limitation consequential or incidental damages. "Typical" parameters that may be provided in NXP data sheets and/or specifications can and do vary in different applications, and actual performance may vary over time. All operating parameters, including "typicals," must be validated for each customer application by customer's technical experts. NXP does not convey any license under its patent rights nor the rights of others. NXP sells products pursuant to standard terms and conditions of sale, which can be found at the following address:

nxp.com/SalesTermsandConditions.

While NXP has implemented advanced security features, all products may be subject to unidentified vulnerabilities. Customers are responsible for the design and operation of their applications and products to reduce the effect of these vulnerabilities on customer's applications and products, and NXP accepts no liability for any vulnerability that is discovered. Customers should implement appropriate design and operating safeguards to minimize the risks associated with their applications and products.

NXP, the NXP logo, NXP SECURE CONNECTIONS FOR A SMARTER WORLD, COOLFLUX, EMBRACE, GREENCHIP, HITAG, I2C BUS, ICODE, JCOP, LIFE VIBES, MIFARE, MIFARE CLASSIC, MIFARE DESFire, MIFARE PLUS, MIFARE FLEX, MANTIS, MIFARE ULTRALIGHT, MIFARE4MOBILE, MIGLO, NTAG, ROADLINK, SMARTLX, SMARTMX, STARPLUG, TOPFET, TRENCHMOS, UCODE, Freescale, the Freescale logo, AltiVec, C-5, CodeTEST, CodeWarrior, ColdFire, ColdFire+, C-Ware, the Energy Efficient Solutions logo, Kinetis, Layerscape, MagniV, mobileGT, PEG, PowerQUICC, Processor Expert, QorIQ, QorIQ Qonverge, Ready Play, SafeAssure, the SafeAssure logo, StarCore, Symphony, VortiQa, Vybrid, Airfast, BeeKit, BeeStack, CoreNet, Flexis, MXC, Platform in a Package, QUICC Engine, SMARTMOS, Tower, TurboLink, and UMEMS are trademarks of NXP B.V. All other product or service names are the property of their respective owners. AMBA, Arm, Arm7, Arm7TDMI, Arm9, Arm11, Artisan, big.LITTLE, Cordio, CoreLink, CoreSight, Cortex, DesignStart, DynamiQ, Jazelle, Keil, Mali, Mbed, Mbed Enabled, NEON, POP, RealView, SecurCore, Socrates, Thumb, TrustZone, ULINK, ULINK2, ULINK-ME, ULINK-PLUS, ULINKpro, μ Vision, Versatile are trademarks or registered trademarks of Arm Limited (or its subsidiaries) in the US and/or elsewhere. The related technology may be protected by any or all of patents, copyrights, designs and trade secrets. All rights reserved. Oracle and Java are registered trademarks of Oracle and/or its affiliates. The Power Architecture and Power.org word marks and the Power and Power.org logos and related marks are trademarks and service marks licensed by Power.org.

© 2018-2020 NXP B.V.

Document Number: IMX8QXPAEC

Rev. 3

05/2020

