



Colour
is our nature

50W DMX/RDM Full-Colour (RGBW) Dimmable LED Driver

POWERdrive

POWERdrive AC's dynamic response can be tuned to fit any content - from exceptionally smooth fades in architecture to fast-paced video in entertainment. This constant current LED driver is DMX/RDM compatible, with a fully isolated DMX/RDM interface to all inputs and outputs.

Product offering

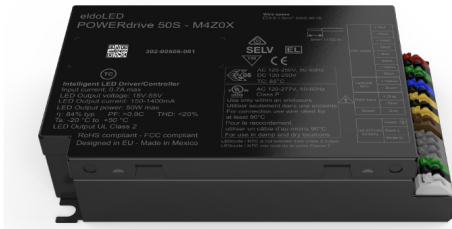

POWERdrive 50S-M4Z0X

Part number P/N	PW50S-M4Z0X1
Product description	POWERdrive AC, 50W, DMX/RDM, 4 control channels, constant current, 4x 55V outputs, side feed, square metal

Features & benefits

Natural dimming	Dim to dark, smooth brightness changes, excellent flicker performance, adaptable dimming curves, configurable minimum dimming level
Programmable	4 x fully programmable, Class-2, constant current LED outputs which operate across a wide operating window
Performance	Universal input voltage range, low inrush current and total harmonic distortion (THD), high power factor and efficiency
Camera compatibility	Hybrid HydraDrive technology is proven to work in TV studios and security camera environments
DMX/RDM	DMX/RDM compatible full-color (RGBW) LED driver
Isolated DMX interface	Improved immunity against surge events and enhanced robustness against accidental mis-wiring

Warranty

Warranty period [General Terms and Conditions](#)

Input characteristics

Nominal input voltage range 120 - 250 VAC (ENEC), 120 - 277 VAC (UL)
120 - 250 VDC

Absolute input voltage range 108 - 305 VAC

Input frequency range 50 - 60Hz

Maximum input current 0.5A @ 120V
0.26A @ 230V
0.22A @ 277V

Efficiency at full load 86%

Power factor at full load >0.95

THD at full load <20%

Maximum inrush current <100mA²s @ 120V
<100mA²s @ 230V
<100mA²s @ 277V

Surge protection 2kV differential mode (DM)
2kV common mode (CM)

Maximum standby power <0.5W

Output characteristics

Maximum LED output power	50W
Number of LED outputs	4 (UL Class 2)
Programmable LED output current range	150 - 1400mA per LED output. The cumulative current across all LED outputs shall not exceed 3400mA at any point in time during normal operation
LED output type	programmable in 1mA steps via DMX terminal and FluxTool
LED output current tolerance	+/- 5% at programmed LED output current
LED output voltage range	2 - 55V

Operating window

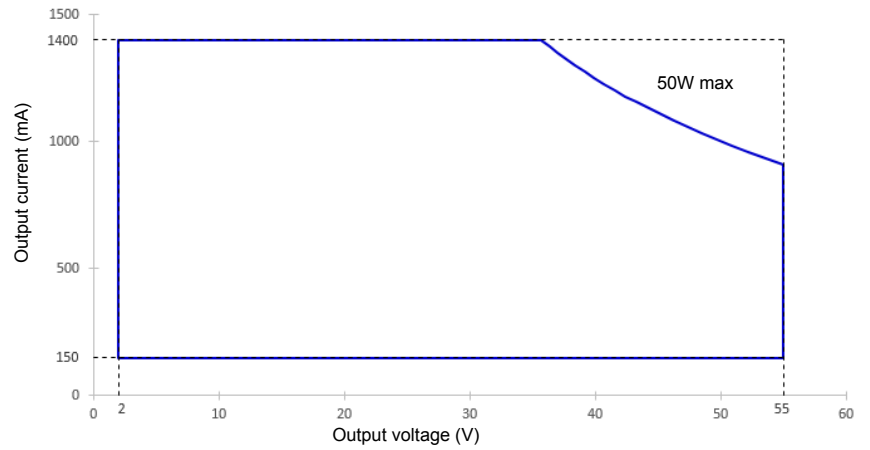

Startup time < 500ms, see Design Guide for details

Control characteristics

Control channels 1 – 4 (default)

Multiple LED outputs can be mapped onto a single DMX group. For more details, see the Design Guide.

Control protocol DMX/RDM

Dimming range 100% - 0.1%

Dimming curve options Logarithmic (default)
Linear
Soft-Linear
Square

Dimming method Hybrid HydraDrive

Dimming curves

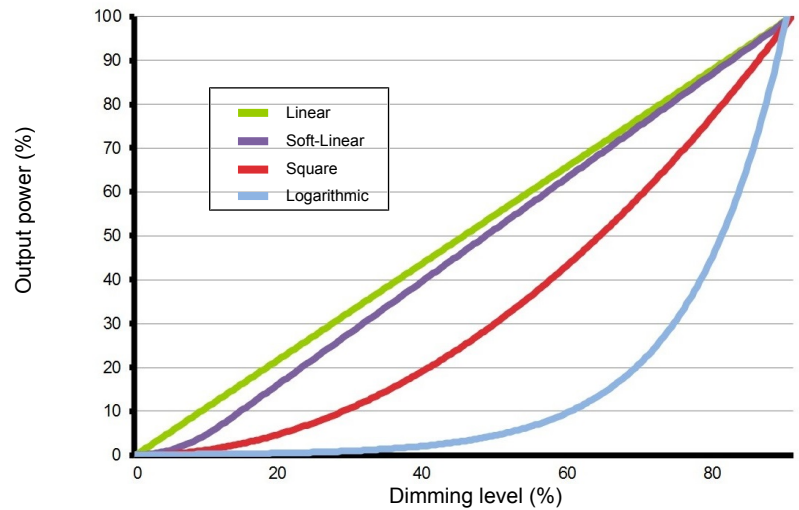

Programming tools

Programming interface [TOOLbox pro \(TLU20504\)](#)

Programming cable set [TOOLbox pro to LED driver, programming cable, 5pcs \(TLC03051\)](#)

Programming Hand-held, Touch-and-Go [PJ0035HH1](#)

Programming software [FluxTool](#)

Performance

Typical efficiency vs load

Tested with a load of 17 LEDs in series, programmed for 225mA and at 25 °C ambient temperature. The measurements below 50W were performed by dimming the light output.

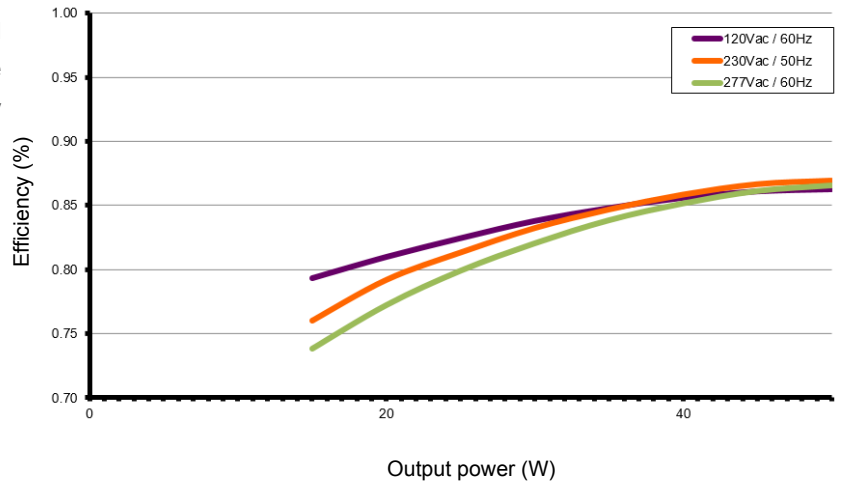

Typical power factor vs load

Tested with a load of 17 LEDs in series, programmed for 225mA and at 25 °C ambient temperature. The measurements below 50W were performed by dimming the light output.

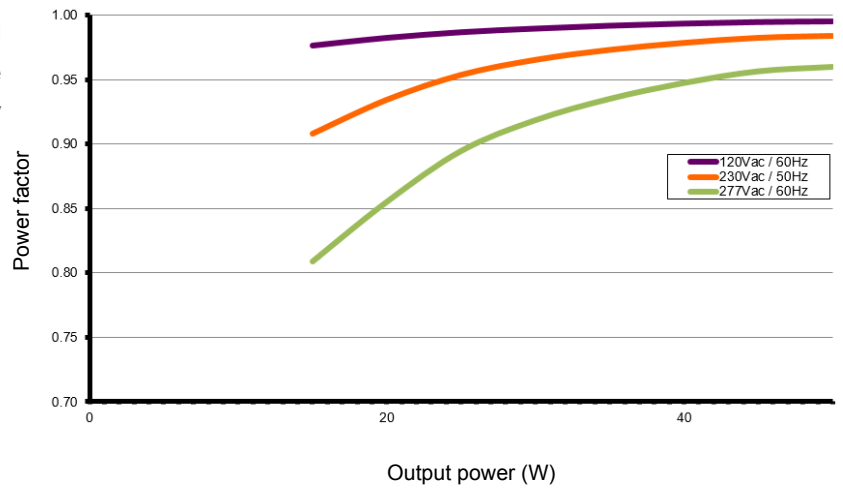

Typical THD vs load

Tested with a load of 17 LEDs in series, programmed for 225mA and at 25 °C ambient temperature. The measurements below 50W were performed by dimming the light output.

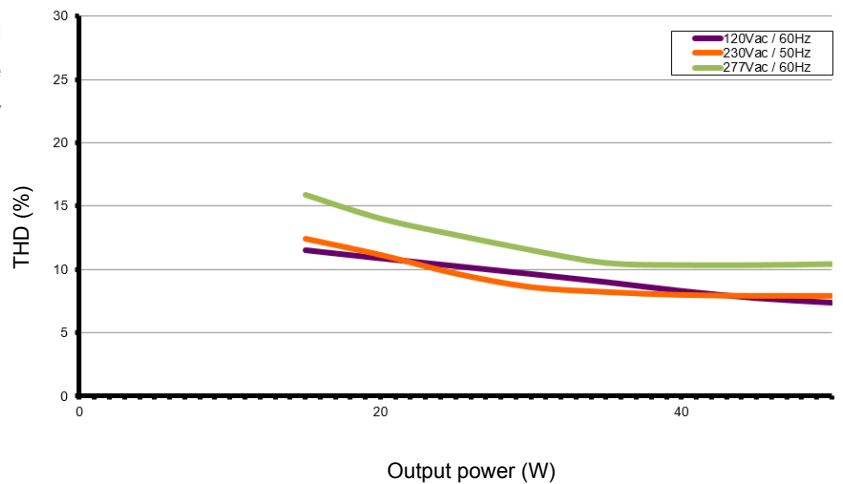

Typical flicker performance

Typical flicker percent as a function of frequency, measured across the dimming range. The results are overlaid with the low-risk (yellow) and no observable effect (green) levels as defined in IEEE P1789.

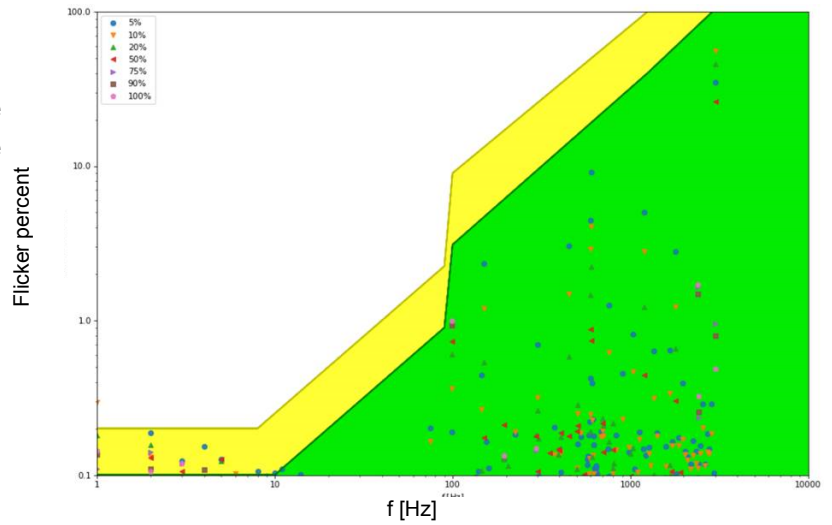

Environmental conditions

Operating ambient temperature (Ta) range -20 °C to +50 °C

Maximum operating case temperature (Tc max) 85 °C

Lifetime 50k hours at a maximum case temperature (Tc) of 85 °C

Tc point location

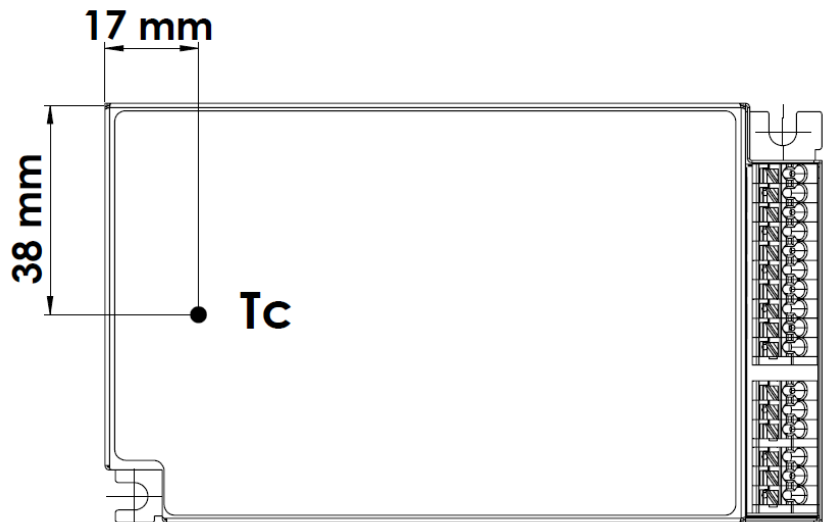

Acoustic noise – steady state <24dBA (Class A)

LED driver protection

Thermal	The LED output current is automatically decreased whenever the internal driver temperature exceeds a factory preset temperature. The LED output current is increased once the internal driver temperature drops below the preset temperature threshold. If the internal driver temperature continues to increase, despite a decrease in output current, the LED driver will eventually shut down.
LED output short circuit	The LED output current is cut off whenever the LED driver detects a short-circuit. The LED driver will attempt a restart every 400ms after a short-circuit is detected.
LED output open circuit	All LED outputs are turned off whenever the LED driver detects an open circuit on any one of the LED outputs. The LED driver will automatically attempt a restart every 400ms after an open circuit is detected.
LED output overload	The driver monitors the cumulative load across all LED outputs. Whenever this cumulative load exceeds the maximum output power rating of the LED driver, the output current on all LED outputs is sequentially scaled down until the cumulative load drops below the maximum output power rating of the LED driver.
Reverse polarity	The LED driver will not yield any current if the polarity of the load on the LED output is reversed. This situation will not damage the LED driver but may damage the LED load.

LED protection

Thermal protection LED	An external NTC thermistor, which is placed on a PCB near the LEDs, can be connected to the driver via the LEDcode/NTC terminals. The output current to the LEDs is then decreased by 75% whenever the NTC exceeds a maximum allowable temperature, which is specified by the user in the FluxTool software. The default NTC temperature limit is set to 70 °C.
Thermistor value	47kΩ
Suitable thermistors	Leaded: Vishay, P/N 238164063473 Screw: Vishay, P/N NTCASCWE3473J

LED driver mechanical details

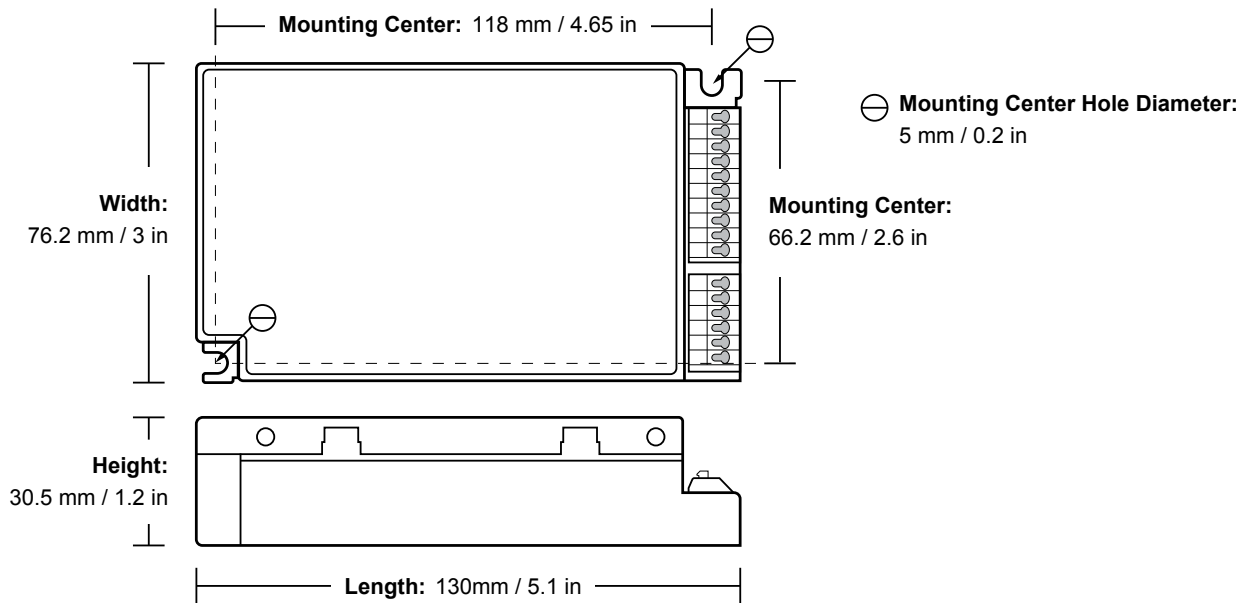

Weight	328 g
Mounting torque	Not to exceed 0.5Nm

3D Mechanical files for this product are available on the eldoLED website.

Packaging

Length x Width x Height	500 x 310 x 190 mm / 19.7 x 12.2 7.5 in
Weight (including products)	13.7 kg
Products per box	40 pcs

Connector layout

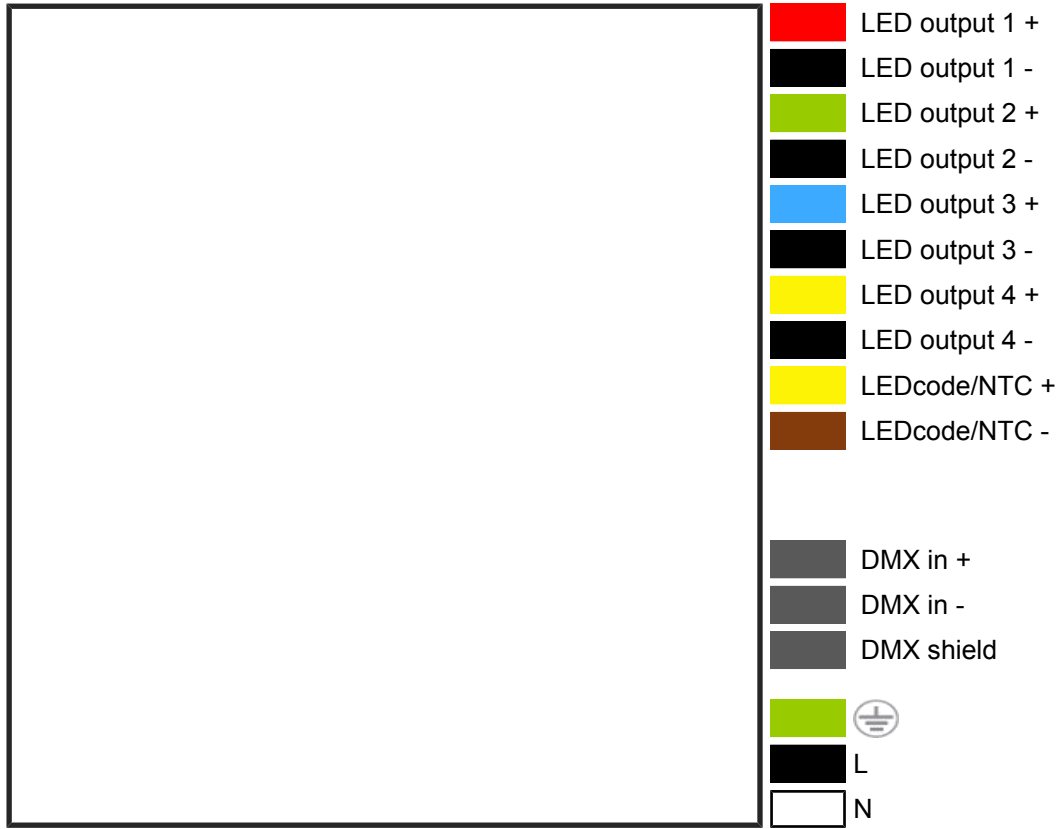

Wiring specifications

Connector type	push-in terminals
Connector supplier and series	Wago 250 / DECA MX522
Wire strip length	9mm (11/31in)
Wire core cross section	AWG 20-16, 0.5 – 1.5 mm ² (mains, LED output, LEDcode) AWG 24-16, 0.2 – 1.5 mm ² (DMX)
Wire Type	UL: solid (mains); solid or stranded (LED outputs, DMX, LEDcode) ENEC: solid or stranded

Automatic circuit breakers (MCB)

Maximum loading	MCB type	B10	B13	B16	C10	C13	C16
	Number of LED drivers (120Vac)	14	16	20	14	16	20
	Number of LED drivers (230Vac)	26	30	38	26	30	38
	Number of LED drivers (277Vac)	31	36	45	31	36	45

Standards and compliance

UL Listed, Class P	UL 1310 UL 8750 (Class 2 output)
ENEC safety	EN 61347-1 EN 61347-2-13 (Emergency lighting)
ENEC performance	EN 62384
Conducted emissions	EN 55015 FCC title 47 CFR part 15 class B
Radiated emissions	EN 55015 FCC title 47 CFR part 15 class B
Radio disturbance characteristics	EN 55022
Harmonic current emissions	EN 61000-3-2
Electrostatic discharge	EN 61000-4-2
RFE field susceptibility	EN 61000-4-3
Electrical fast transient	EN 61000-4-4
Surge immunity	EN 61000-4-5
Conducted radio frequency	EN 61000-4-6
Voltage dips	EN 61000-4-11
Electromagnetic immunity	EN 61547
ECodesign 2019/2020: Controlgear + luminaire	Flicker for LED: Pst LM ≤ 1.0 at full-load Stroboscopic effect for LED: SVM ≤ 0.4 at full load
DMX	ANSI E1.11 – 2008 (R2013), USITT DMX512-A ANSI E1.20 - 2010
Surge protection mains	IEC 61000-4-5 level 3: 2kV DM, 2kV CM @ 2 Ohm ANSI 62.41 1991 category B1: 2.5kV DM, 2.5kV CM @ 30 Ohm
Surge protection DMX	1kV CM
RCM	AS/NZS 61347.1, AS/NZS 61347.2.13
Restriction of hazardous substances	RoHS3 (Directives 2011/65/EU-2015/863/EU)
SVHC-list substances	REACH Art.33

Certifications



Order number configurator

<p>Standard</p>	<p>PW50S-M4Z0X1 Part Number</p>	<p><input type="text"/><input type="text"/><input type="text"/><input type="text"/> mA LED Output Current</p>	<p><input type="text"/><input type="text"/><input type="text"/> Dimming Curve</p>	<p><input type="text"/><input type="text"/> . <input type="text"/> min Minimum Dimming Level</p>	<p>RDM <input type="text"/><input type="text"/><input type="text"/> RDM Settings ID</p>
		<p><input type="text"/><input type="text"/><input type="text"/><input type="text"/><input type="text"/><input type="text"/><input type="text"/><input type="text"/><input type="text"/><input type="text"/> Default Start-Up and Fail Mode</p>			
<p>Multi-Current</p>	<p>PW50S-M4Z0X1 Part Number</p>	<p>M C U R LED Output Current</p>	<p><input type="text"/><input type="text"/><input type="text"/> Dimming Curve</p>	<p><input type="text"/><input type="text"/> . <input type="text"/> min Minimum Dimming Level</p>	<p>CH1 - <input type="text"/><input type="text"/><input type="text"/><input type="text"/> mA LED Output 1</p>
		<p>CH2 - <input type="text"/><input type="text"/><input type="text"/><input type="text"/> mA LED Output 2</p>	<p>CH3 - <input type="text"/><input type="text"/><input type="text"/><input type="text"/> mA LED Output 3</p>	<p>CH4 - <input type="text"/><input type="text"/><input type="text"/><input type="text"/> mA LED Output 4</p>	
		<p>RDM <input type="text"/><input type="text"/><input type="text"/> RDM Settings ID</p>	<p><input type="text"/><input type="text"/><input type="text"/><input type="text"/><input type="text"/><input type="text"/><input type="text"/><input type="text"/><input type="text"/><input type="text"/> Default Start-Up and Fail Mode</p>		

LED output current Enter value in 1mA increments, e.g. "811" for 811mA. The POWERdrive 50W/U driver is designed to deliver, by default, the specified output current on each LED output. If the output current is different per LED output, enter "MCUR" in LED output current and specify the differing output currents in LED Outputs 1/2/3/4.

Dimming curve "LOG" for logarithmic (default)
"LIN" for linear
"SLN" for soft-linear
"SQU" for square

Minimum dimming level Leave blank for default minimum dimming level of 0.1%. Specify in 0.1% increments, e.g. "10.5" for 10.5%.

RDM Settings ID The RDM Settings ID is a reference to a variety of RDM settings (e.g. Manufacturer ID, Device Model Description, RDM IDs) that are stored in the driver from the eldoLED factory. These settings cannot be changed by the user. RDM001 is the default RDM Settings ID and corresponds to the default eldoLED RDM settings. Customer-specific RDM settings can be programmed into the driver in the eldoLED factory. Contact your sales representative if custom settings are desired.

Default start-up and fail mode Enter "ENTM" to start-up the driver at 20% and retain its last value with the loss of DMX (**default**).

To create a custom configuration, specify the start-up and DMX drop levels for all LED outputs using the format: S____D____, where S____ defines the start-up level and D____ defines the DMX drop level for LED outputs 1 - 4. Specify S____DR if the last value must be retained when the DMX signal is dropped. The underscores in this custom configuration can be [0-9, F] corresponding to the option values in the table below. Make sure that the total output power and cumulative current of all LED outputs do not exceed the maximum ratings of the driver. For example specify S000FDR for an RGBW application that starts with only the 4th LED output (white) at 100% of the nominal drive current and retains the last value for every LED output when the DMX signal is dropped.

Selection	Description	Selection	Description
0%	0	60%	6
10%	1	70%	7
20%	2	80%	8
30%	3	90%	9
40%	4	100%	F
50%	5		

Safety



Risk of electrical shock. May result in serious injury or death. Disconnect power before servicing or installing.



The LED driver may only be connected and installed by a qualified electrician. All applicable regulations, legislation, and building codes must be observed. Incorrect installation of the LED driver can cause irreparable damage to the LED driver and the connected LEDs.

Pay attention when connecting the LEDs: polarity reversal results in no light output and often damages the LEDs.



LED drivers are designed and intended to operate LED loads only. Powering non-LED loads may push the LED driver outside its specified design limits and is, therefore, not covered by any warranty.



eldoLED products are designed to meet the performance specifications as outlined at certain operating conditions in the data sheet. It is the responsibility of the fixture manufacturer to test and validate the design and operation of the system under expected and potential use cases, including faults.



Please observe voltage drop over long cable lengths. Longer cable lengths increase EMI susceptibility.



Product renderings and dimensional drawings are generic for the housing type. Product label, connector type and quantity may vary.

Europe, Rest of World

eldoLED B.V.
Science Park Eindhoven 5125
5692 ED Son
The Netherlands

E: info@eldoled.com
W: www.eldoled.com

North America

eldoLED America
One Lithonia Way
Conyers, GA 30012
USA

E: info@eldoled.com
W: www.eldoled.com
