

© 2021 TE Connectivity. All Rights Reserved.

REVISIONS

P	LTR	DESCRIPTION	DATE	DWN	APVD
	T	REDRAWN. PLASTIC SUPPLIER CHANGED	28MAY2021	SB	KJK

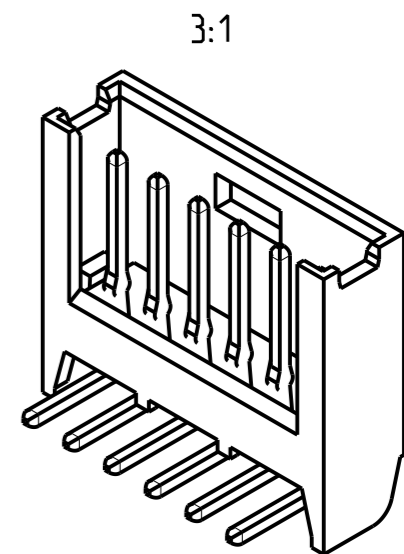
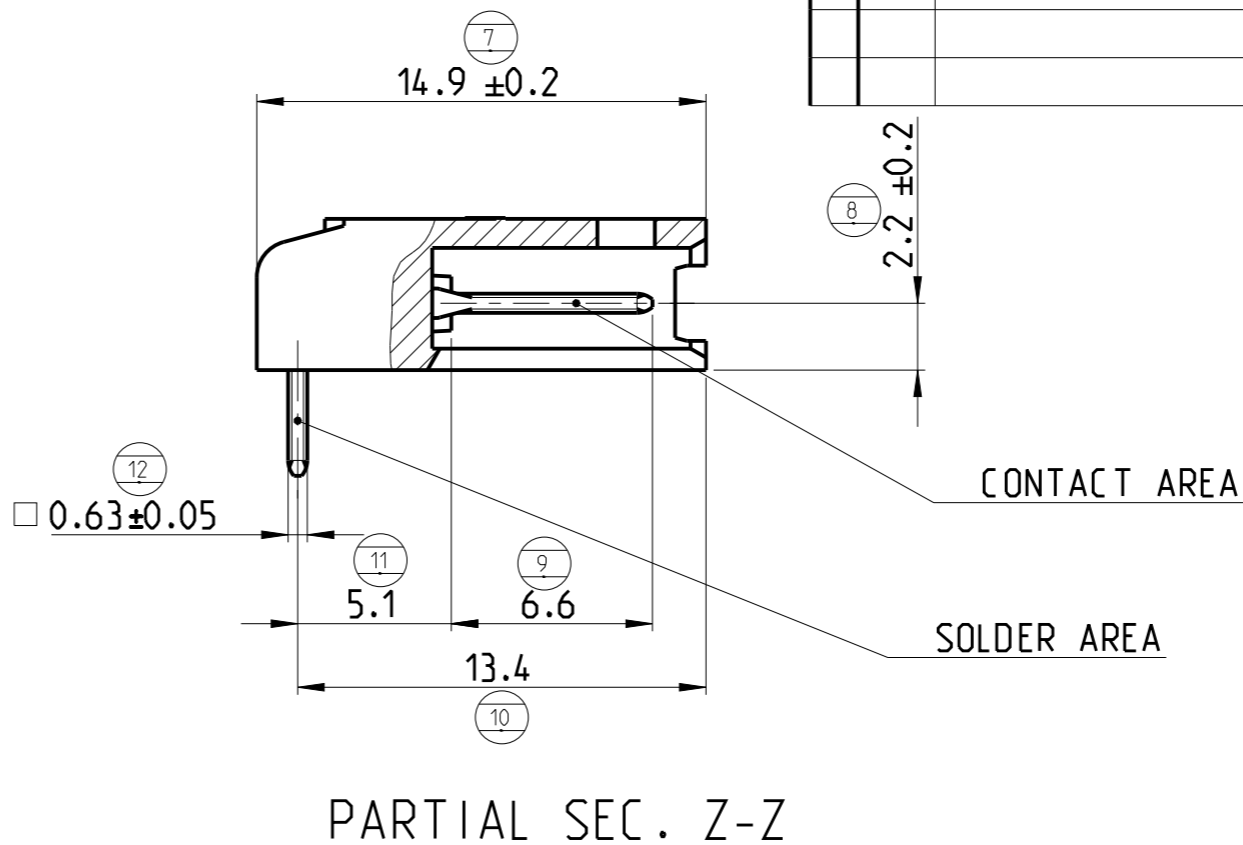
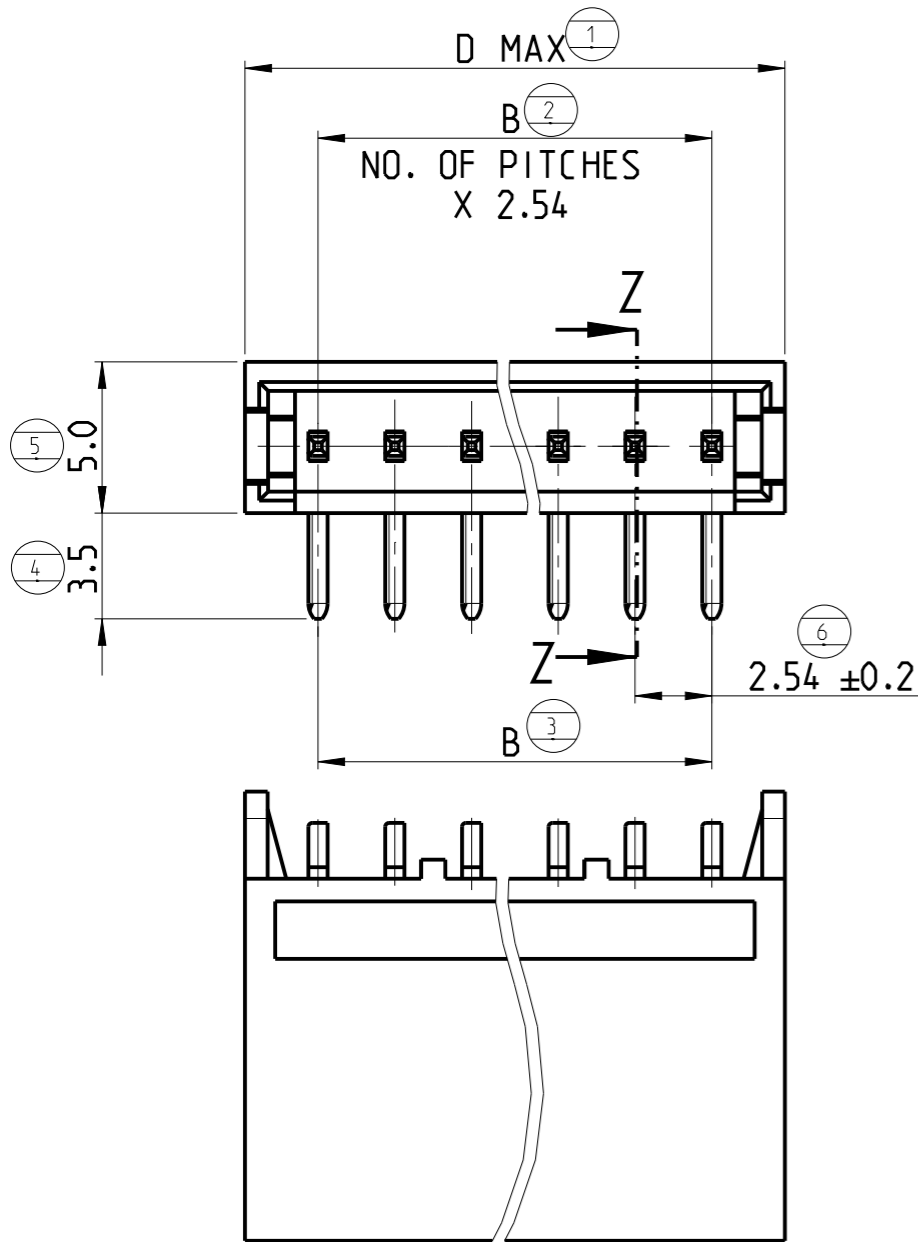

NOTES:

- 1 FINISH: 3-5 μm TIN OVER MIN 1.27 μm NICKEL
- 2 FINISH: DUPLEX PLATED MIN 0.38 μm GOLD IN CONTACT AREA AND 2.5 μm TIN IN SOLDER AREA. OVER MIN 1.27 μm NICKEL.
- 3 FINISH: DUPLEX PLATED MIN 0.76 μm GOLD IN CONTACT AREA AND 2.5 μm TIN IN SOLDER AREA. OVER MIN 1.27 μm NICKEL.
- 4 MATERIALS:
-HOUSINGS: FLAME RETARDANT THERMOPLASTIC. UL94V0. COLOR BLACK.
-TIN AND GOLD PLATED CONTACTS: BRASS
- 5 OBSOLETE
- 6 RECOMMENDED PCB HOLES DIA: 1.1⁺⁰_{-0.2}; 0.75 MIN. ADMITTED FOR 2 POS. ONLY

58.5	53.34	5	280383-3	280383-2	280383-1	22	
40.7	35.56	5	280382-3	280382-2	280382-1	15	
33.1	27.94	5	280523-3	280523-2	280523-1	12	
28.0	22.86		280381-3	280381-2	280381-1	10	
25.4	20.32	5	280511-3	280511-2	280511-1	9	
22.9	17.78		280380-3	280380-2	280380-1	8	
17.8	12.70		280379-3	280379-2	280379-1	6	
12.7	7.62		280378-3	280378-2	280378-1	4	
7.7	2.54		280377-3	280377-2	280377-1	2	
D	B	3	PART NUMBER	2	PART NUMBER	1	PART NUMBER NO. POS.

THIS DRAWING IS A CONTROLLED DOCUMENT.		DWN G. CAMPIA 12FEB1990		
DIMENSIONS: mm		CHK -		
TOLERANCES UNLESS OTHERWISE SPECIFIED: 0 PLC ±0.3 1 PLC ± 2 PLC ± 3 PLC ± 4 PLC ± ANGLES ±2°		APVD -	NAME AMPMODU II SHROUDED HEADER SINGLE ROW, RIGHT ANGLE POST	
MATERIAL 4		PRODUCT SPEC 108-20025	SIZE A3	
		APPLICATION SPEC -	CAGE CODE 00779	DRAWING NO C-280377
		WEIGHT -	RESTRICTED TO	
		CUSTOMER DRAWING	SCALE 4:1	SHEET 1 OF 1