

FEATURES:

- Low Power Consumption
- Exceptional Stability Over Temp. at -40°C to +85°C
- Available over Extended Temp Range
- Low Cost-Compact QFN Plastic Packaging
- Compact Package design

APPLICATIONS:

- CCD Clock for VTR Camera
- Equipment Connected to PCs
- Low Profile Equipment
- Lower Cost Crystal Oscillator Replacement
- Computers and Peripherals
- Portable Electronics (MP3 Players, Games)
- Consumer Electronics such as TV's, DVR's, etc.
- Vibrant, Shock-Prone & Humid Environments for Industrial Equipment
- Demanding Military & Automotive Electronics

STANDARD SPECIFICATIONS:

Parameters		Minimum	Typical	Maximum	Units	Notes
Frequency Range:		1.0	-----	150	MHz	
Operating Temperature:		0	-----	+70	°C	See options
Storage Temperature:		-55	-----	+150	°C	
Supply Voltage (Vdd):		+1.8 ~ +3.3			V	See options
Supply Current (no load):	1.0 to 39.9999MHz	-----	7	15	mA	Vdd=3.3V No load RL=∞ T=25°C
	40.0 to 79.9999MHz	-----	8	15		
	80.0 to 124.9999MHz	-----	9	15		
	125.0 to 150MHz	-----	10	15		
Output Voltage:	V _{OH}	0.8*V _{dd}	-----	-----	V	15pF
	V _{OL}	-----	-----	0.2*V _{dd}		
Rise Time:	Tr	-----	1.3	3.0	ns	15pF; T=25°C 20%/80%*VDD
Fall Time:	Tf	-----	1.3	3.0		
Output Load:		15pF max / 10kΩ min.			pF	See options
Symmetry:		45	-----	55	%	@1/2Vdd
Startup Time:		-----	1.5	3.0	ms	
Disable Time:		-----	20	100	ns	
Disable Stand-by Current:		-----	-----	15	uA	
Tri-state Function (Stand-by) :		"1" (VIH≥0.75*Vdd) or Open: Oscillation "0" (VIH<0.25*Vdd) : Hi Z			V	
Cycle to cycle jitter:		-----	60	-----	ps	F=100MHz
Aging:		-5.0	-----	+5.0	ppm	First year

Absolute Maximum Ratings

Item	Minimum	Maximum	Unit	Condition
Supply Voltage	-0.3	+4.0	V	
Input Voltage	-0.3	Vdd+0.3	V	
Junction Temp.	-----	+150	°C	
Soldering Temp.	-----	+260	°C	40sec max
ESD			V	
HBM		2,000		
MM		200		
CDM		500		



➤ **PART NUMBER FOR PROGRAMMED ORDERS (Quantity > 1,000pcs)**

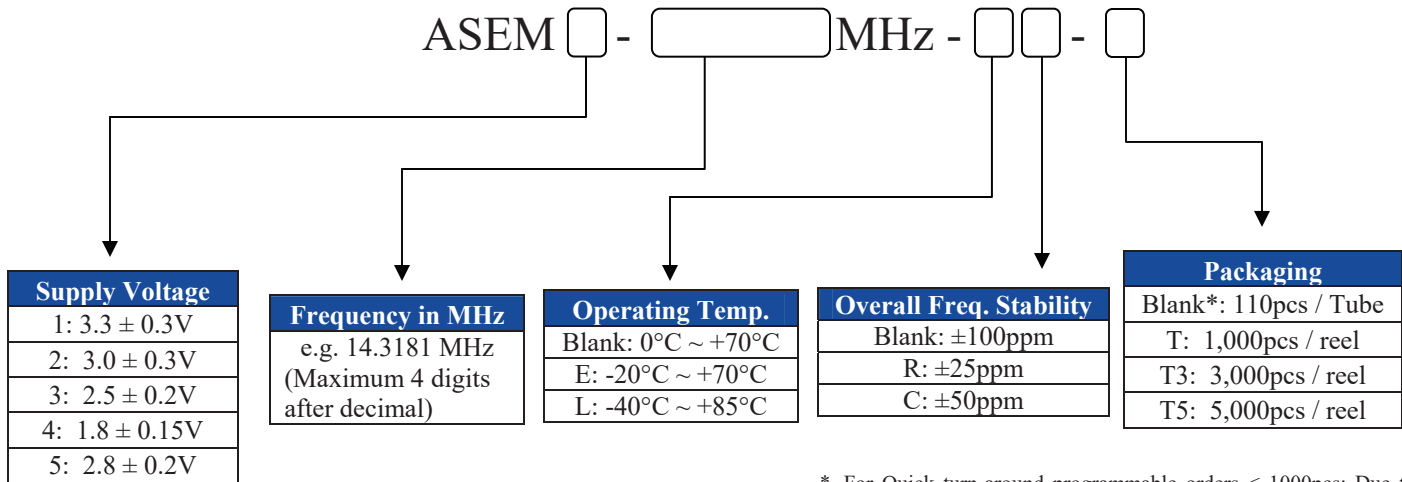

* For Quick turn-around programmable orders < 1000pcs: Due to the immediate availability of stock and the qty of the order, the parts may be delivered as BULK: Cut Tape, Loose parts in Antistatic Bag or in Tube(s). The MOQ per the series will still apply for Tube packaging.

Un-Programmed Orders (Quantity < 1,000pcs)

Blank un-programmed oscillators are available for quick turn engineering requirements. Please call ABRACON for more information.

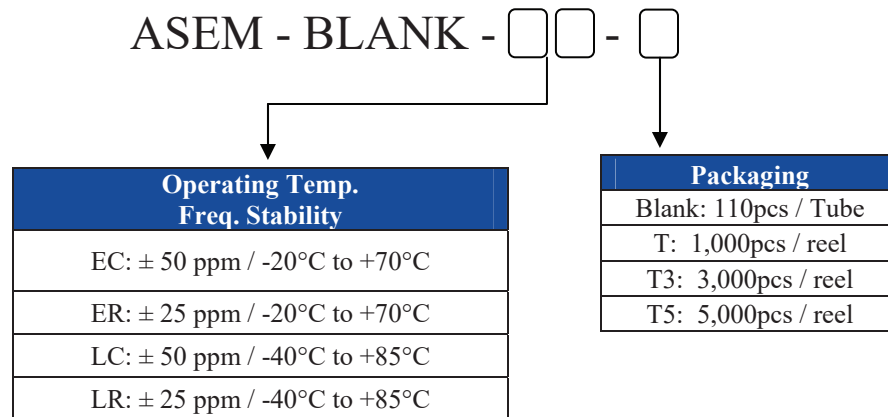

MEMS CLOCK OSCILLATOR

ASEM



Life Size

3.2 x 2.5 x 0.85 mm

ASEM

Pb | RoHS/RoHS II Compliant

OUTLINE DRAWING:

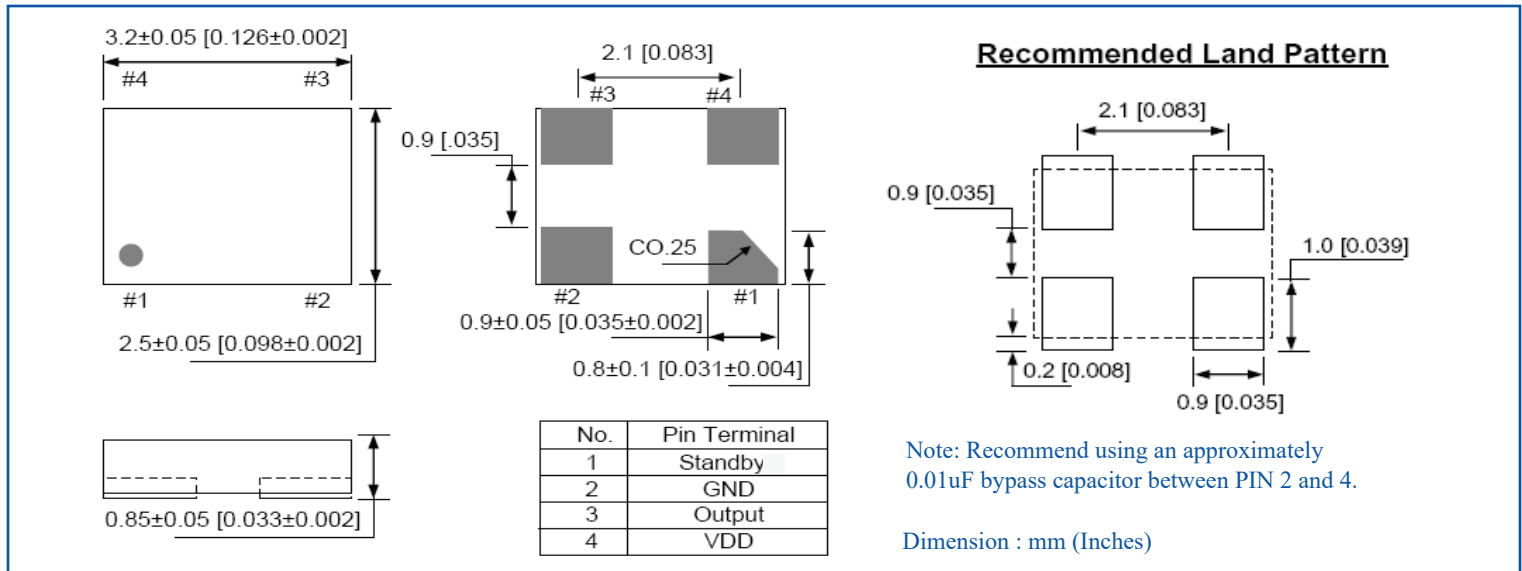

TAPE & REEL: Tape and reel 1,000pcs/reel

REFLOW PROFILE:

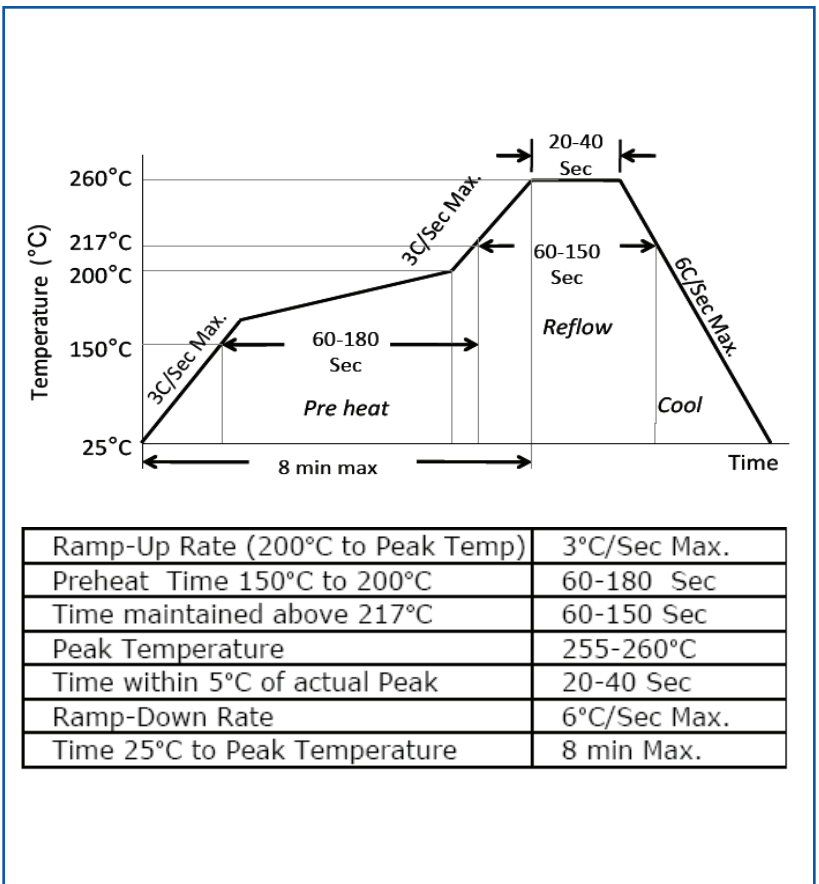
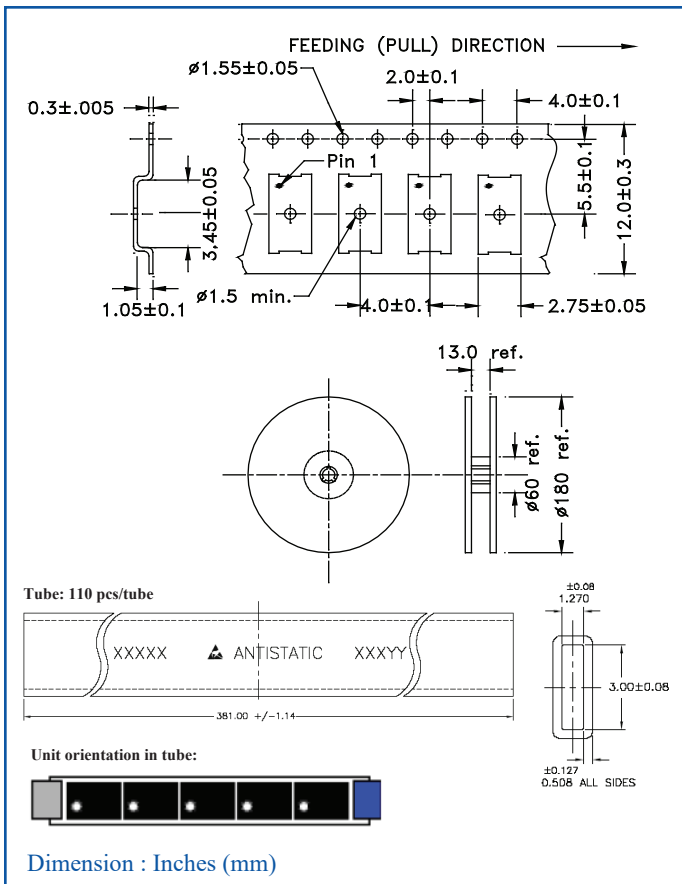

ATTENTION: Abracon LLC's products are COTS – Commercial-Off-The-Shelf products; suitable for Commercial, Industrial and, where designated, Automotive Applications. Abracon's products are not specifically designed for Military, Aviation, Aerospace, Life-dependent Medical applications or any application requiring high reliability where component failure could result in loss of life and/or property. For applications requiring high reliability and/or presenting an extreme operating environment, written consent and authorization from Abracon LLC is required. Please contact Abracon LLC for more information.

REVISED: 1.4.2021



5101 Hidden Creek Ln Spicewood TX 78669
 Phone: 512-371-6159 | Fax: 512-351-8858
 For terms and conditions of sales, please visit: www.abracon.com

ABRACON IS
 ISO9001-2015
 CERTIFIED

Mouser Electronics

Authorized Distributor

Click to View Pricing, Inventory, Delivery & Lifecycle Information:

ABRACON:

[ASEM1-30.000MHZ-LC-T](#) [ASEM1-1.8432MHZ-LC-T](#) [ASEM1-60.000MHZ-LC-T](#) [ASEM1-24.000MHZ-LC-T](#) [ASEM1-24.576MHZ-LC-T](#) [ASEM1-18.432MHZ-LC-T](#) [ASEM1-25.000MHZ-LC-T](#) [ASEM1-8.000MHZ-LC-T](#) [ASEM1-20.000MHZ-LC-T](#) [ASEM1-10.000MHZ-LC-T](#) [ASEM1-14.7456MHZ-LC-T](#) [ASEM1-12.000MHZ-LC-T](#) [ASEM1-4.000MHZ-LC-T](#) [ASEM1-29.4912MHZ-LC-T](#) [ASEM1-33.000MHZ-LC-T](#) [ASEM1-33.333MHZ-LC-T](#) [ASEM1-50.000MHZ-LC-T](#) [ASEM1-14.31818MHZ-LC-T](#) [ASEM1-48.000MHZ-LC-T](#) [ASEM1-11.0592MHZ-LC-T](#) [ASEM1-27.000MHZ-LC-T](#) [ASEM1-16.000MHZ-LC-T](#) [ASEM1-100.000MHZ-LC-T](#) [ASEM1-80.000MHZ-LC-T](#)