

- Compact half-brick package
- Ultra wide 4:1 input voltage ranges  
9–36, 18–75, 43–160 VDC
- EN 50155 approval for railway applications
- Very high efficiency up to 93%
- No minimum load
- Soft start
- Adjustable output voltage +10/-20%
- Sense line
- Remote On/Off input
- Under voltage lock-out circuit
- 3-year product warranty



The TEP 100WIR Series is a family of isolated high performance DC/DC converter modules with ultra-wide 4:1 input voltage ranges which come in a rugged, sealed industry standard half brick package. A very high efficiency allows full power operation without forced air cooling at 60°C This temperature can be increased to 70°C with optional mounted heatsink or up to 85°C when mounted on an iron base plate. The very wide input voltage range make these converters interesting solution for battery operated systems. Typical applications are in telecom/datacom, industry control and railway systems for on board power distribution. These series is available in many optional designs on demand

Models				
Order Code	Input Voltage Range	Output Voltage nom. (adjustable)	Output Current max.	Efficiency typ.
TEP 100-2411WIR	9 - 36 VDC (24 VDC nom.)	5 VDC (4.0 - 5.5 VDC)	20'000 mA	93 %
TEP 100-2412WIR		12 VDC (9.6 - 13.2 VDC)	8'400 mA	90 %
TEP 100-2415WIR		24 VDC (19.2 - 26.4 VDC)	4'200 mA	90 %
TEP 100-2416WIR		28 VDC (22.4 - 30.8 VDC)	3'600 mA	90 %
TEP 100-2418WIR		48 VDC (38.4 - 52.8 VDC)	2'100 mA	90 %
TEP 100-4812WIR	18 - 75 VDC (48 VDC nom.)	12 VDC (9.6 - 13.2 VDC)	8'400 mA	90 %
TEP 100-4815WIR		24 VDC (19.2 - 26.4 VDC)	4'200 mA	90 %
TEP 100-4816WIR		28 VDC (22.4 - 30.8 VDC)	3'600 mA	92 %
TEP 100-4818WIR		48 VDC (38.4 - 52.8 VDC)	2'100 mA	91 %
TEP 100-7212WIR	43 - 160 VDC (110 VDC nom.)	12 VDC (9.6 - 13.2 VDC)	8'400 mA	90 %
TEP 100-7215WIR		24 VDC (19.2 - 26.4 VDC)	4'200 mA	90 %
TEP 100-7216WIR		28 VDC (22.4 - 30.8 VDC)	3'600 mA	90 %
TEP 100-7218WIR		48 VDC (38.4 - 52.8 VDC)	2'100 mA	91 %

Options	
<b>TEP-HS1</b>	- Optional Heat Sink: <a href="http://www.tracopower.com/overview/tep-hs1">www.tracopower.com/overview/tep-hs1</a>
<b>on demand</b> (backorder with MOQ non stocking item)	<ul style="list-style-type: none"> <li>- Optional model with 3.3 VDC and 25'000 mA Output, and 9 - 36 VDC Input</li> <li>- Optional model with 15 VDC and 6'700 mA Output, and 9 - 36 VDC Input</li> <li>- Optional model with 3.3 VDC and 25'000 mA Output, and 18 - 75 VDC Input</li> <li>- Optional model with 5 VDC and 20'000 mA Output, and 18 - 75 VDC Input</li> <li>- Optional model with 15 VDC and 6'700 mA Output, and 18 - 75 VDC Input</li> <li>- Optional model with 3.3 VDC and 25'000 mA Output, and 43 - 160 VDC Input</li> <li>- Optional model with 5 VDC and 20'000 mA Output, and 43 - 160 VDC Input</li> <li>- Optional model with 15 VDC and 6'700 mA Output, and 43 - 160 VDC Input</li> <li>- Optional models with inverse Remote On/Off function (passive = off)</li> <li>- Chassis mount models w/o filter: <a href="http://www.tracopower.com/overview/tep100wircm">www.tracopower.com/overview/tep100wircm</a></li> <li>- Chassis mount models w/ filter to meet EN 55032 class A: <a href="http://www.tracopower.com/overview/tep100wircmf">www.tracopower.com/overview/tep100wircmf</a></li> </ul>

Input Specifications	
Input Current	- At no load 110 Vin models: <b>10 mA typ.</b> 24 Vin models: <b>20 mA typ.</b> (3.3 Vout model) <b>25 mA typ.</b> (5 Vout model) <b>25 mA typ.</b> (12 Vout model) <b>25 mA typ.</b> (15 Vout model) <b>25 mA typ.</b> (24 Vout model) <b>25 mA typ.</b> (28 Vout model) <b>35 mA typ.</b> (48 Vout model) 48 Vin models: <b>15 mA typ.</b> (3.3 Vout model) <b>15 mA typ.</b> (5 Vout model) <b>20 mA typ.</b> (12 Vout model) <b>20 mA typ.</b> (15 Vout model) <b>20 mA typ.</b> (24 Vout model) <b>20 mA typ.</b> (28 Vout model) <b>25 mA typ.</b> (48 Vout model)
Surge Voltage	24 Vin models: <b>50 VDC max.</b> (1 s max.) 48 Vin models: <b>100 VDC max.</b> (1 s max.) 110 Vin models: <b>185 VDC max.</b> (1 s max.)
Under Voltage Lockout	24 Vin models: <b>7.3 VDC min. / 7.5 VDC typ. / 8.1 VDC max.</b> 48 Vin models: <b>15.5 VDC min. / 16 VDC typ. / 16.3 VDC max.</b> 110 Vin models: <b>33 VDC min. / 34.5 VDC typ. / 36 VDC max.</b>
Recommended Input Fuse	24 Vin models: <b>20'000 mA</b> (fast acting) 48 Vin models: <b>12'000 mA</b> (fast acting) 110 Vin models: <b>5'000 mA</b> (slow blow) (The need of an external fuse has to be assessed in the final application.)
Input Filter	<b>Internal Pi-Type</b>

Output Specifications	
Output Voltage Adjustment	-20% to +10% (By external trim resistor) See application note: <a href="http://www.tracopower.com/tep100wir-adj">www.tracopower.com/tep100wir-adj</a> Output power must not exceed rated power!
Voltage Set Accuracy	<b>±1% max.</b>
Regulation	- Input Variation (Vmin - Vmax) <b>0.1% max.</b> - Load Variation (0 - 100%) <b>0.1% max.</b>

All specifications valid at nominal voltage, resistive full load and +25°C after warm-up time, unless otherwise stated.

Ripple and Noise (20 MHz Bandwidth)	3.3 Vout models: <b>75 mVp-p max.</b> (w/ 1 $\mu$ F X7R    22 $\mu$ F poscap) 5 Vout models: <b>75 mVp-p max.</b> (w/ 1 $\mu$ F X7R    22 $\mu$ F poscap) 12 Vout models: <b>100 mVp-p max.</b> (w/ 1 $\mu$ F X7R    22 $\mu$ F poscap) 15 Vout models: <b>100 mVp-p max.</b> (w/ 1 $\mu$ F X7R    22 $\mu$ F poscap) 24 Vout models: <b>200 mVp-p max.</b> (w/ 4.7 $\mu$ F X7R) 28 Vout models: <b>200 mVp-p max.</b> (w/ 4.7 $\mu$ F X7R) 48 Vout models: <b>300 mVp-p max.</b> (w/ 2.2 $\mu$ F X7R)
Capacitive Load	3.3 Vout models: <b>75'700 <math>\mu</math>F max.</b> 5 Vout models: <b>40'000 <math>\mu</math>F max.</b> 12 Vout models: <b>7'000 <math>\mu</math>F max.</b> 15 Vout models: <b>4'460 <math>\mu</math>F max.</b> 24 Vout models: <b>1'750 <math>\mu</math>F max.</b> 28 Vout models: <b>1'280 <math>\mu</math>F max.</b> 48 Vout models: <b>430 <math>\mu</math>F max.</b>
Minimum Load	<b>Not required</b>
Temperature Coefficient	<b><math>\pm 0.02</math> %/K max.</b>
Hold-up Time	<b>10 ms min.</b> (acc. to EN 50155 Class S2, see application note for ext. capacitor calculation: <a href="http://www.tracopower.com/info/holdup_en50155.pdf">www.tracopower.com/info/holdup_en50155.pdf</a> )
Start-up Time	<b>75 ms typ.</b>
Short Circuit Protection	<b>Continuous, Automatic recovery</b>
Output Current Limitation	<b>150% typ. of Iout max.</b> (110 Vin models) <b>120 - 150% (other models)</b>
Oversvoltage Protection	<b>115 - 130% of Vout nom.</b>
Transient Response - Response Time	<b>200 <math>\mu</math>s typ. / 250 <math>\mu</math>s max.</b> (25% Load Step)

## Safety Specifications

Standards	- IT / Multimedia Equipment  - Railway Applications - Certification Documents	EN 60950-1 EN 62368-1 IEC 60950-1 IEC 62368-1 UL 60950-1 UL 62368-1 EN 50155 <a href="http://www.tracopower.com/tep100wir-safety-cert">www.tracopower.com/tep100wir-safety-cert</a>
Energy Source	- Output, acc. to 62368-1	ES2 (for TEP 100-7218WIR) ES1
Power Source	- Output, acc. to 62368-1	PS3
Over Voltage Category		Not mains connected

## EMC Specifications

EMI (Emissions)	- Conducted Emissions  - Radiated Emissions	EN 50121-3-2 (EMC for Rolling Stock) EN 55011 class A (with external filter) EN 55011 class B (with external filter) EN 55032 class A (with external filter) EN 55032 class B (with external filter) EN 55011 class A (with external filter) EN 55011 class B (with external filter) EN 55032 class A (with external filter) EN 55032 class B (with external filter)
		External filter proposal: <a href="http://www.tracopower.com/tep100wir-emc-filter">www.tracopower.com/tep100wir-emc-filter</a>

All specifications valid at nominal voltage, resistive full load and +25°C after warm-up time, unless otherwise stated.

<b>EMS (Immunity)</b>	<ul style="list-style-type: none"> <li>- Electrostatic Discharge</li> <li>- RF Electromagnetic Field</li> <li>- EFT (Burst) / Surge</li> <li>- Conducted RF Disturbances</li> <li>- PF Magnetic Field</li> </ul>	<p>EN 50121-3-2 (EMC for Rolling Stock)  EN 55024 (IT Equipment)  EN 55035 (Multimedia)</p> <p>Air: EN 61000-4-2, <math>\pm 8</math> kV, perf. criteria A  Contact: EN 61000-4-2, <math>\pm 6</math> kV, perf. criteria A  EN 61000-4-3, 20 V/m, perf. criteria A  EN 61000-4-4, <math>\pm 2</math> kV, perf. criteria A  EN 61000-4-5, <math>\pm 2</math> kV, perf. criteria A</p> <p>Ext. input component: 24 &amp; 48 Vin models: 2 x KY 220 <math>\mu</math>F 100 V  110 Vin models: 2 x KXJ 150 <math>\mu</math>F 200 V  EN 61000-4-6, 10 Vrms, perf. criteria A</p> <p>Continuous: EN 61000-4-8, 100 A/m, perf. criteria A  1 s: EN 61000-4-8, 1000 A/m, perf. criteria A</p>
<b>EMC / Environmental</b>	- Certification Documents	<a href="http://www.tracopower.com/tep100wir-emc-cert">www.tracopower.com/tep100wir-emc-cert</a>

## General Specifications

<b>Relative Humidity</b>		95% max. (non condensing)
<b>Temperature Ranges</b>	<ul style="list-style-type: none"> <li>- Operating Temperature</li> <li>- Case Temperature</li> <li>- Storage Temperature</li> </ul>	<p>-40°C to +75°C  +105°C max.  -55°C to +125°C</p>
<b>Power Derating</b>	- High Temperature	Depending on model
		See application note: <a href="http://www.tracopower.com/tep100wir-cc">www.tracopower.com/tep100wir-cc</a>
<b>Over Temperature Protection Switch Off</b>	<ul style="list-style-type: none"> <li>- Protection Mode</li> <li>- Measurement Point</li> </ul>	115°C typ. (Automatic recovery at 105°C typ.) Base-Plate
<b>Cooling System</b>		Natural convection (20 LFM)
<b>Sense Function</b>		10% max. of Vout nom.  (If sense function is not used, sense pins must be connected to corresponding polarity output pins.)
<b>Remote Control</b>	<ul style="list-style-type: none"> <li>- Voltage Controlled Remote (passive = on)</li> <li>- Off Idle Input Current</li> <li>- Remote Pin Input Current</li> </ul>	<p>On: 3.0 to 12 VDC or open circuit  Off: 0 to 1.2 VDC or short circuit  Refers to 'Remote' and '-Vin' Pin  3 mA typ.  -0.5 to 1.0 mA  (Optional models with inverse Remote On/Off function (passive = off))</p>
<b>Altitude During Operation</b>		2'000 m max. (for reinforced insulation) 5'000 m max. (for functional insulation)
<b>Switching Frequency</b>		300 kHz typ. (PWM) ( $\pm 10\%$ , 110 Vin models) 250 kHz typ. (PWM) ( $\pm 10\%$ , other models)
<b>Insulation System</b>		Reinforced Insulation
<b>Working Voltage (rated)</b>		145 VAC (24/48 Vin and 3.3/5 Vout models) 185 VAC (24/48 Vin and 48 Vout models) 172 VAC (24/48 Vin and other Vout models) 177 VAC (110 Vin models)
<b>Isolation Test Voltage</b>	<ul style="list-style-type: none"> <li>- Input to Output, 60 s</li> <li>- Input to Case, 60 s</li> <li>- Output to Case, 60 s</li> </ul>	3'000 VAC 1'500 VAC 1'500 VAC
<b>Isolation Resistance</b>	- Input to Output, 500 VDC	1'000 M $\Omega$ min.
<b>Isolation Capacitance</b>	- Input to Output, 100 kHz, 1 V	2'500 pF max.
<b>Reliability</b>	- Calculated MTBF	409'000 h (MIL-HDBK-217F, ground benign)
<b>Washing Process</b>		According to Cleaning Guideline <a href="http://www.tracopower.com/info/cleaning.pdf">www.tracopower.com/info/cleaning.pdf</a>

All specifications valid at nominal voltage, resistive full load and +25°C after warm-up time, unless otherwise stated.

Environment	- Vibration  - Mechanical Shock  - Thermal Shock - Flammability	MIL-STD-810F EN 61373 MIL-STD-810F EN 61373 MIL-STD-810F EN 45545-2 <a href="http://www.tracopower.com/info/en45545-declaration.pdf">www.tracopower.com/info/en45545-declaration.pdf</a>
Housing Material		Alu base-plate w. metal case (24 and 48 Vin models) Alu base-plate w. plastic case (110 Vin models)
Base Material		Non-conductive FR4 (UL 94 V-0 rated) (24 and 48 Vin models only)
Potting Material		Silicone (UL 94 V-0 rated)
Pin Material		Copper
Pin Foundation Plating		Nickel (2 - 3 µm)
Pin Surface Plating		Tin (3 - 5 µm), matte
Housing Type		Metal Case (24 and 48 Vin models) Plastic Case (110 Vin models)
Mounting Type		PCB Mount
Connection Type		THD (Through-Hole Device)
Footprint Type		Half-Brick
Soldering Profile		Lead-Free Wave Soldering 260°C / 6 s max.
Weight		105 g
Thermal Impedance	- Case to Ambient	6.7 K/W typ. 4.7 K/W typ. (with heatsink TEP-HS1)
Environmental Compliance	- REACH Declaration  - RoHS Declaration  - SCIP Reference Number	<a href="http://www.tracopower.com/info/reach-declaration.pdf">www.tracopower.com/info/reach-declaration.pdf</a> REACH SVHC list compliant REACH Annex XVII compliant <a href="http://www.tracopower.com/info/rohs-declaration.pdf">www.tracopower.com/info/rohs-declaration.pdf</a> Exemptions: 7(a), 7(c)-I (RoHS exemptions refer to the component concentration only, not to the overall concentration in the product (O5A rule).) 4e8cc3a5-c3ec-44b0-9980-158ec468eab5

### Additional Information

Supporting Documents	<a href="http://www.tracopower.com/overview/tep100wir">www.tracopower.com/overview/tep100wir</a>
Frequently Asked Questions	<a href="http://www.tracopower.com/glossary-faq">www.tracopower.com/glossary-faq</a>
Glossary	<a href="http://www.tracopower.com/info/glossary.pdf">www.tracopower.com/info/glossary.pdf</a>

All specifications valid at nominal voltage, resistive full load and +25°C after warm-up time, unless otherwise stated.

### Outline Dimensions

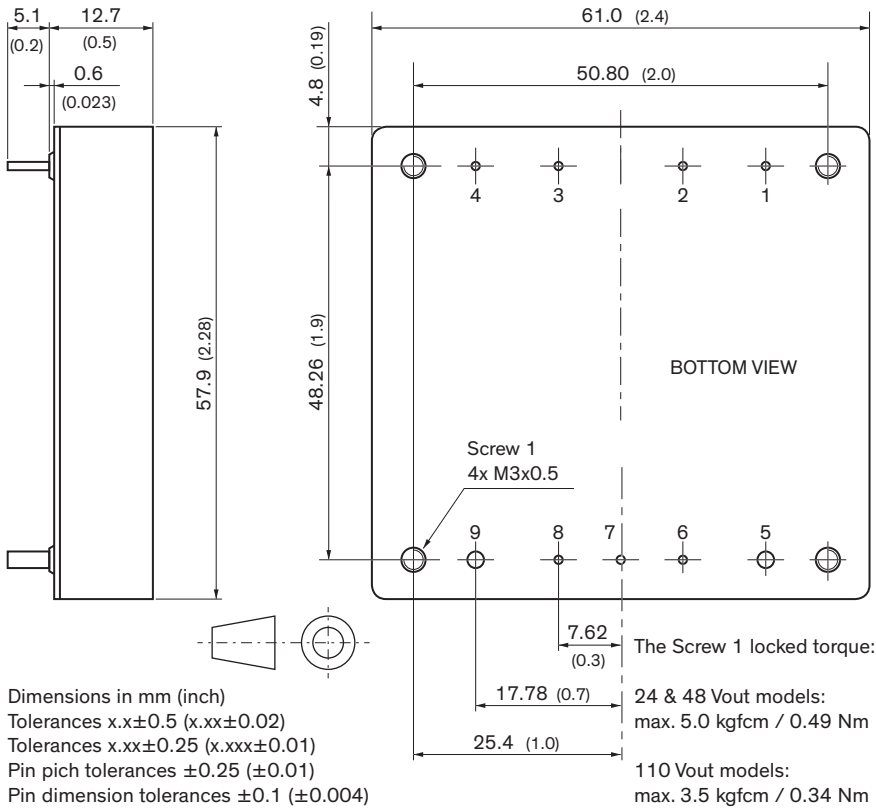

Pinout		
Pin	Single	Pin Diameter
1	-Vin (GND)	1.0 mm (0.04 inch)
2	Case	1.0 mm (0.04 inch)
3	Remote On/Off	1.0 mm (0.04 inch)
4	+Vin (Vcc)	1.0 mm (0.04 inch)
5	-Vout	2.0 mm (0.08 inch)
6	-Sense	1.0 mm (0.04 inch)
7	Trim	1.0 mm (0.04 inch)
8	+Sense	1.0 mm (0.04 inch)
9	+Vout	2.0 mm (0.08 inch)