

175/180/200W Configurable ac/dc power supply.

Features	Benefits
• High efficiency	Minimises heat in system
• Low profile	Fits 1U applications
• High power density	Reduces space requirement
• Temperature controlled fan option	Reduces system noise
• 3 year warranty	Low cost of ownership



Input			
Input Voltage	90-264Vac 133-388Vdc also available, contact sales	Input Frequency	45 - 63Hz (440Hz with reduced PFC - consult sales office)
Input Harmonics	EN61000-3-2 compliant	Inrush Current	<40A at 25°C and 230Vac (cold start)
Input Fuse	Timelag (not user accessible)	Earth Leakage Current	123µA at 120Vac (60Hz), 257µA max at 240Vac (60Hz) Worst case leakage current is less than 300µA at 264Vac, 63Hz (normal condition, 500µA Single Fault Condition)

Available Outputs							
Channel 1	Adjustment Range	Channel 2 ₁	Adjustment Range	Channel 3 ₃	Adjustment Range	Channel 4 ₄	Adjustment Range
5 5V / 25A ₂	5 - 5.5V	1 1.8V / 15A 2 2.7V / 15A 3 3.3V / 15A 0 Omit	0.9 - 2.5V 2.5 - 3.3V 2.5 - 3.3V	T 12V / 5A F 15V / 5A G 24V / 2.5A 0 Omit	12 - 15V 12 - 15V 18 - 24V	T -12V / 1A F -15V / 1A 3H -3.3V / 2A ₉ 5H -5V / 2A ₉ TH -12V / 2A ₉ FH -15V / 2A ₉ 0H Fan supply only 0 Omit	Fixed Fixed Fixed Fixed Fixed Fixed
T 12V / 15A F 15V / 12A	12 - 15V ₅ 12 - 15V ₆	5 5V / 10A ₁₀ 0 Omit	3.3 - 5.5V				
G 24V / 7.5A	24 - 28V ₇	5 5V / 8A ₈ 0 Omit	3.3 - 5.5V				

- 1.8V, 2.7V, 3.3V channel 2 only available with 5V Channel 1
5V/10A channel 2 only available with 12V or 15V Channel 1
5V/8A channel 2 only available with 24V Channel 1.
- Maximum combined output current from Ch1 & Ch2 = 25A
Models with 5V channel 1 are limited to 175W output power
- Follow letters in red by 'Y' for negative output channel 3.
- Follow letters in red by 'P' for positive output channel 4.
- 12 - 12.5V if 24V channel 3 fitted.
- 14.5 - 15V if 24V channel 3 fitted
- 24 - 24.5V if 5V channel 2 fitted
24 - 26V if 24V channel 3 fitted.
- 7A max with '-F' or '-I' option.
- 1.5A max with '-F' or '-I' option.
- 9A max with '-F' or '-I' option.

Other output options are available, please contact sales office with your requirements

Isolation		
Input to Output	2 x MOOPs (3rd edition 60601) 4.3kVdc	Medical reinforced (2 x MOPPs) version available, contact sales office for details.
Input to Earth	1 x MOOP (3rd edition 60601) 1.5kVac, 2.3kVdc	
Output to Earth	200Vdc	

How To Create A Product Description

Confirm availability of created product with TDK-Lambda

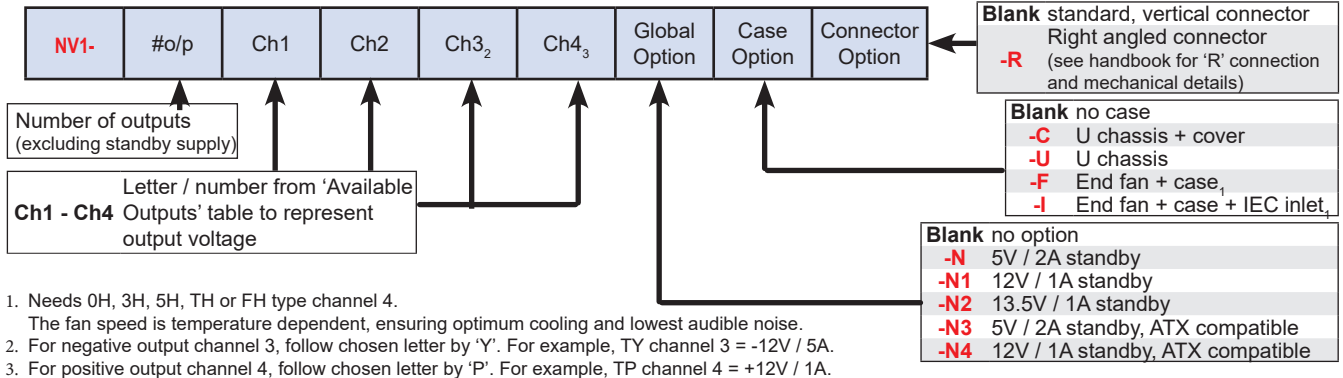

Output Specification

Turn on time	1.5s max	at 90Vac and 100% rated output power
Efficiency	up to 90%	configuration dependent
Hold up	16ms min	at 90Vac
Ripple and Noise	<1%	(or 50mV if higher) pk-pk, using EIAJ test method & 20MHz bandwidth
Voltage Accuracy	±1%	±4% for Channel 4 with 'T' or 'F' type outputs, +4/-3% for all other channel 4.
Remote Sense	Yes	Channels 1 & 2. Max 0.5V total line drop
Minimum Load	No	on any output
Total Regulation	1% (or 50mV if greater)	Including Line (for 90-264Vac input change), Load (for 0-100% load change) and Cross (for 0-100% load change on any other output) regulation.
Transient Response	<4%	of set voltage for 50% load change (in 50µs within the range 25-100% load)
Recovery	500µs	for recovery to 1% of set voltage
Over Voltage Protection	Yes	See Application Notes for details
Short Circuit Protection	Yes	
Over Temperature Protection	Yes	
Peak Output Power	200W	Single output units with 12V, 15V or 24V (T, F or G). Average output power must not exceed 180W over any 5 minute period
Ch1 Good Signal	Yes	Provides a Logic 'Low' signal after Channel 1 output is within 90% (±5%) of nominal

QUICK SELECTOR - example configurations

Model	Ch1	Ch2	Ch3	Ch4	Ch5	Global Option
NV1-1T000	12V / 15A	-	-	-	-	No
NV1-1G000	24V / 7.5A	-	-	-	-	No
NV1-453TT	5V / 25A	3.3V / 15A	12V / 5A	-12V / 1A	-	No
NV1-453TT-N3	5V / 25A	3.3V / 15A	12V / 5A	-12V / 1A	5V / 2A	ATX (-N3)
NV1-453FF	5V / 25A	3.3V / 15A	15V / 5A	-15V / 1A	-	No
NV1-453FF-N3	5V / 25A	3.3V / 15A	15V / 5A	-15V / 1A	5V / 2A	ATX (-N3)
NV1-4G5TT	24V / 7.5A	5V / 8A	12V / 5A	-12V / 1A	-	No
NV1-4G5TT-N3	24V / 7.5A	5V / 8A	12V / 5A	-12V / 1A	5V / 2A	ATX (-N3)
NV1-4G5FF	24V / 7.5A	5V / 8A	15V / 5A	-15V / 1A	-	No
NV1-4G5FF-N3	24V / 7.5A	5V / 8A	15V / 5A	-15V / 1A	5V / 2A	ATX (-N3)

Additional variants available 'Built to Order' - see 'How to create a product description'

Global Signals (-N, -N1 and -N2 option models)	
Remote on/off	TTL logic level high inhibits all outputs (except Standby)
Power Good	Open collector output (referenced to PSU 0V). Turns on to indicate ac supply is good and output 1 is within regulation.
Standby Supply	Isolated supply, not affected by remote on/off -N option = 5V / 2A (2.5A peak) -N1 Option = 12V / 1A -N2 Option = 13.5V / 1A

Global Signals (-N3 and -N4 option models)	
ATX Remote on/off	TTL logic level high or open circuit inhibits all outputs (except Standby)
ATX Power Good	Logic high indicates ac supply is good and output 1 is within regulation.
Standby Supply	Common 0V with power supply. Not affected by ATX remote on/off -N3 option = 5V / 2A -N4 Option = 12V / 1A

Immunity EN61000-6-2:2005, EN60601-1-2:2007				Criteria
Electrostatic Discharge	EN61000-4-2	Level 4	Air discharge 15kV, Contact discharge 8kV. Not applicable to open frame units	A
Electromagnetic Field	EN61000-4-3	Level 3	12V/m	A
Fast / Burst Transient	EN61000-4-4	Level 4	ac input tested to 4.4kV dc output tested to 2.2kV	A
Surge Immunity	EN61000-4-5	Level 3	Common mode - 2.2kV, Differential - 1.1kV	A
Conducted RF Immunity	EN61000-4-6	Level 3	12V	A
Power Frequency Magnetic Field	EN61000-4-8	Level 4	30A/m	A
Voltage Dips, Variations, Interruptions	EN61000-4-11	Class 3	Criteria B for 5 sec interruption and dips to 40% for 5 cycles below 154Vac nominal input	A

Emissions EN61000-6-3:2007, EN60601-1-2:2007		
Radiated Electric Field	EN55011, EN55032	(as per CISPR.11/22) Class B, FCC47 part 15 subpart B see application note for details. Additional filtering is required for IEC inlet version
Conducted Emissions	EN55011, EN55032	(as per CISPR.11/22) Class B, FCC47 part 15 subpart B
Conducted Harmonics	EN61000-3-2	Class A
Flicker	EN61000-3-3	Compliant - d_{max} only

Environment	
Temperature	0°C to 50°C operational, -40°C to 70°C storage. Full load, with either '-F' option fitted or 2m/s air blown from input to output (approximately 10CFM)
Derating	50°C to 70°C derate each output by 2.5% per °C
Low Temp Startup	-20°C
Humidity	5 - 95% RH non condensing
Shock	±3 x 30g shocks in each plane, total 18 shocks 30g shock = 11ms (+/-0.5msec), half sine Conforms to EN60068-2-27, EN60068-2-47, IEC68-2-27, IEC68-2-47, JIS C0041-1987. Conforms to MIL-STD-810E/F, Method 516.5, Pro I, IV, VI
Vibration	Single axis 10 - 500 Hz at 2g (sweep and endurance at resonance) in all 3 planes Conforms to EN60068-2-6, IEC68-2-6 Conforms to MIL-STD-810E, Method 514.4, Pro I, Cat 1,9
Altitude	3000 metres operational
Pollution	Degree 2, Material group IIIb

Approvals / Accreditations	
IEC/EN 62368-1, UL62368-1 / CSA 22.2 No 62368-1	File E135494
IEC/EN 60950-1, UL60950-1 / CSA 22.2 No 60950-1	File E135494
IEC/EN 60601-1, UL/CSA 60601-1, ANSI/AAMI ES60601-1 CAN/CSA-C22.2 No 60601-1-08	File E349607
IEC/EN61010	File E331788
CE Mark (EN62368-1)	Low Voltage Directive (LVD), electromagnetic compatibility (EMC) and Restriction of Hazardous Substances (RoHS)
UKCA (EN62368-1)	Electrical Equipment (Safety) Regulations, electromagnetic compatibility (EMC) and Restriction of Hazardous Substances (RoHS)
CB certificate and Report available on request	<i>Please check with technical sales for status of approvals</i>
Designed and manufactured under the control of ISO9001 and ISO13485 (including risk management).	

Outline & Connection Drawings

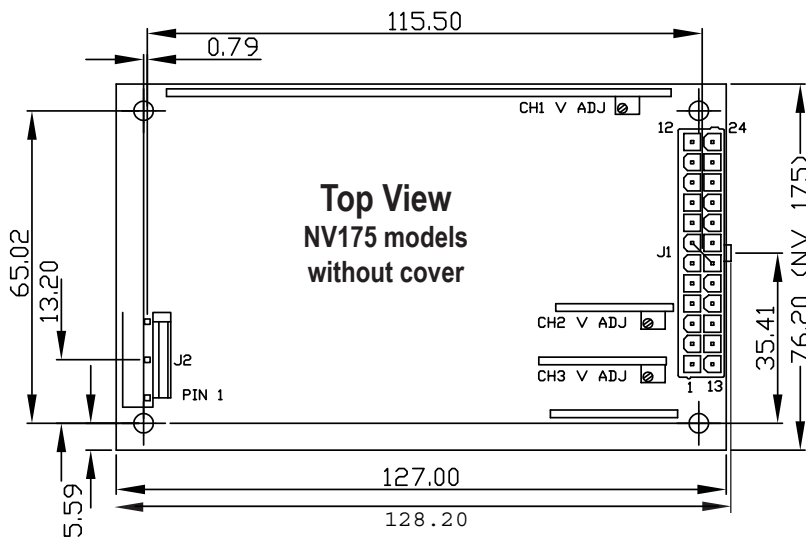

J2

PIN	FUNCTION
1	EARTH
2	NOT CONNECTED
3	LIVE
4	NOT CONNECTED
5	NEUTRAL

J1

PIN	FUNCTION	PIN	FUNCTION
12	STANDBY +Ve	24	STANDBY RETURN
11	POWER GOOD	23	REMOTE ON/OFF
10	CH1 OUTPUT	22	CH1 GOOD
9	CH1 OUTPUT	21	CH1 OUTPUT
8	CH1 OUTPUT	20	CH1 OUTPUT
7	+SENSE CH1	19	-SENSE CH1
6	0V COMMON	18	0V COMMON
5	0V COMMON	17	0V COMMON
4	CH2 OUTPUT	16	0V COMMON
3	CH2 OUTPUT	15	CH2 OUTPUT
2	+SENSE CH2	14	-SENSE CH2
1	CH3 OUTPUT	13	CH4 OUTPUT

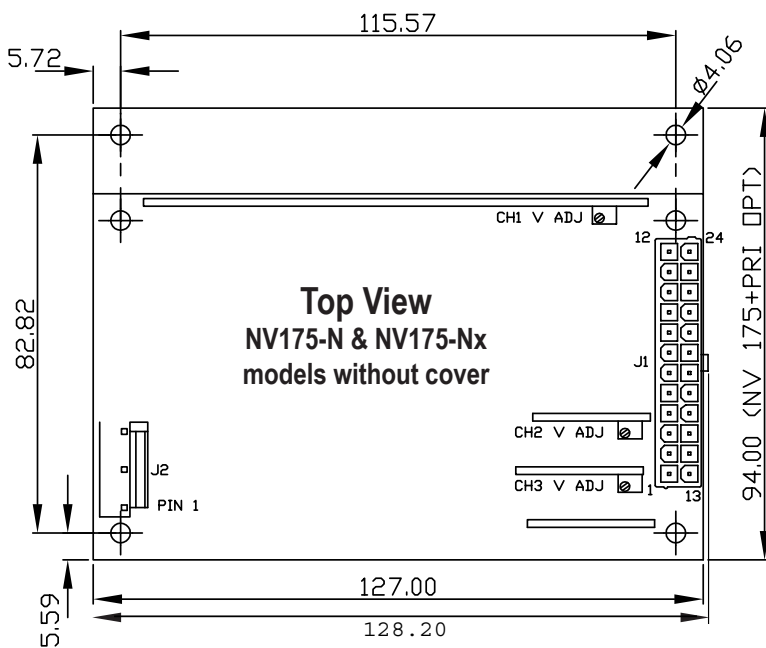

MATING PARTS (MOLEX OR EQUIVALENT)

CONN	HOUSING	PINS
J1	39-01-2245	44476-3112
J2	09-50-8051	08-52-0113

Input and output connectors are not included with the product. They are available from TDK-Lambda

Part Number	Contents
94910	1 off input connector and 3 crimps
94911	1 off output connector and 24 crimps

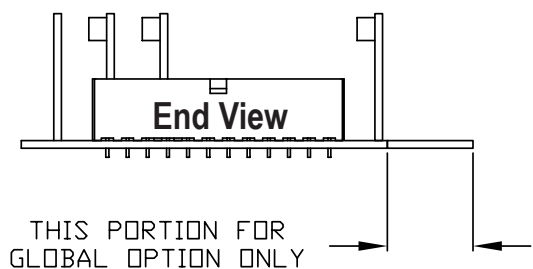
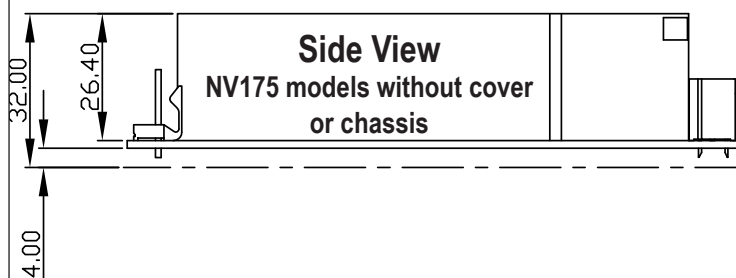

Notes: 1. All customer fixings M3 2. Maximum thread penetration 4.5mm 3. Maximum torque 0.9Nm 4. All tolerances +/-0.5mm

Outline & Connection Drawings

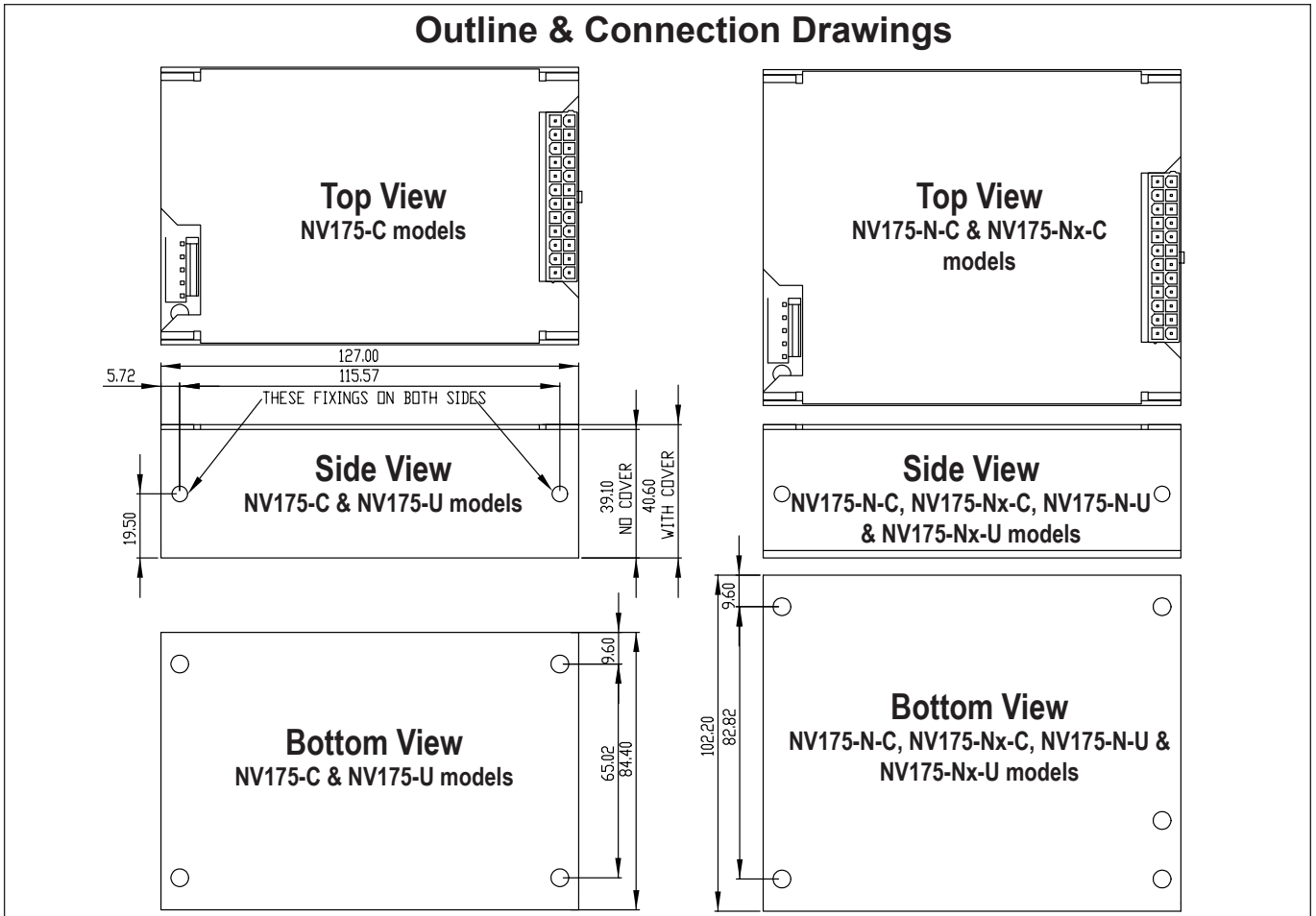

NV-175 units with fan (-F or -I)

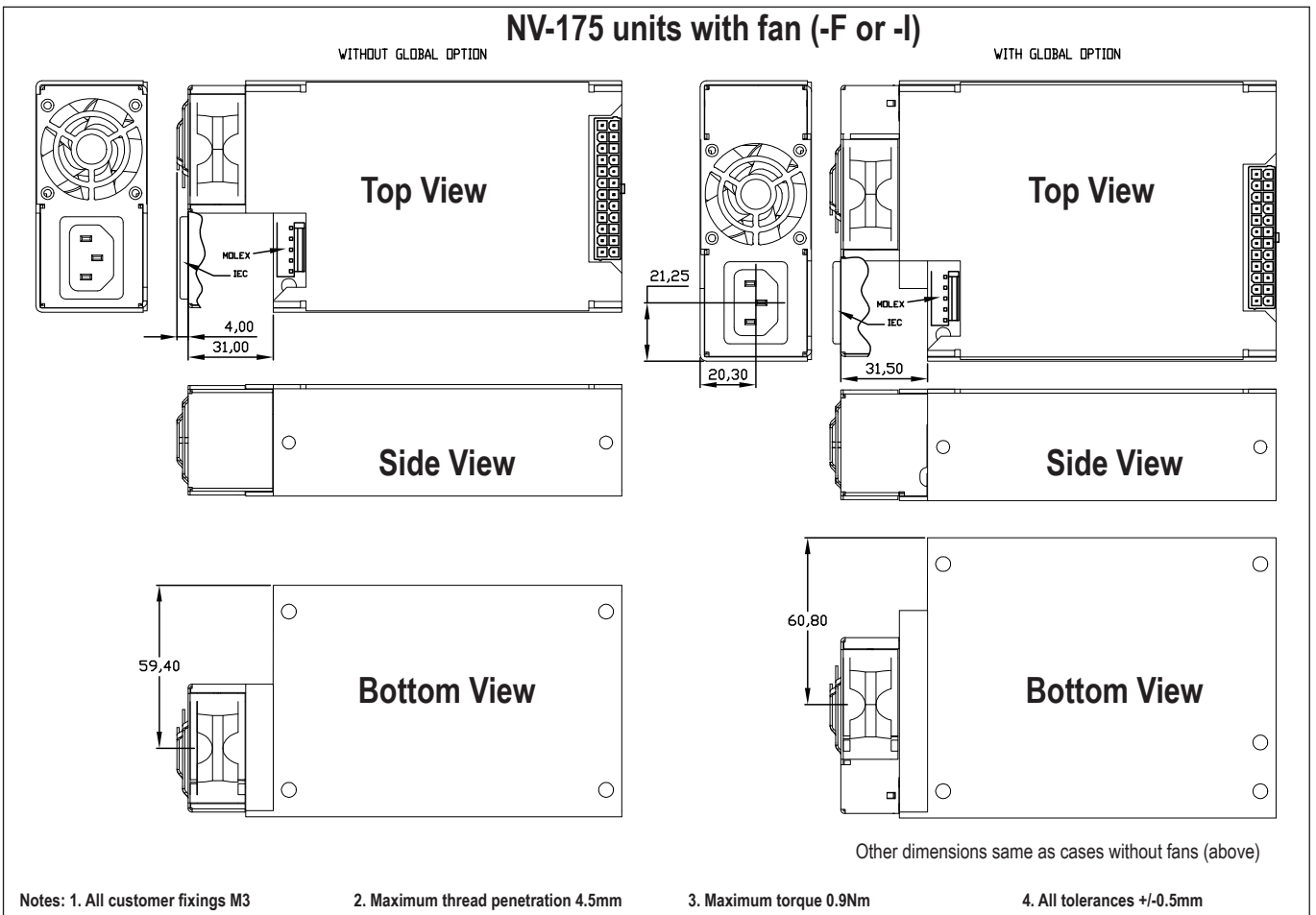



TDK-Lambda France SAS
 Tel: +33 1 60 12 71 65
 ttf.fr-powersolutions@tdk.com
 www.emea.lambda.tdk.com/fr



Italy Sales Office
 Tel: +39 02 61 29 38 63
 ttf.it-powersolutions@tdk.com
 www.emea.lambda.tdk.com/it



Netherlands
 ttf.nl-powersolutions@tdk.com
 www.emea.lambda.tdk.com/nl



TDK-Lambda Germany GmbH
 Tel: +49 7841 666 0
 tig.powersolutions@tdk.com
 www.emea.lambda.tdk.com/de



Austria Sales Office
 Tel: +43 2256 655 84
 tig.at-powersolutions@tdk.com
 www.emea.lambda.tdk.com/at



Switzerland Sales Office
 Tel: +41 44 850 53 53
 tig.ch-powersolutions@tdk.com
 www.emea.lambda.tdk.com/ch



Nordic Sales Office
 Tel: +45 8853 8086
 tig.dk-powersolutions@tdk.com
 www.emea.lambda.tdk.com/dk



TDK-Lambda UK Ltd.
 Tel: +44 (0) 12 71 85 66 66
 tlu.powersolutions@tdk.com
 www.emea.lambda.tdk.com/uk



TDK-Lambda Ltd.
 Tel: +9 723 902 4333
 tli.powersolutions@tdk.com
 www.emea.lambda.tdk.com/il-en



TDK-Lambda Americas
 Tel: +1 800-LAMBDA-4 or 1-800-526-2324
 tla.powersolutions@tdk.com
 www.us.lambda.tdk.com



TDK Electronics do Brasil Ltda
 Tel: +55 11 3289-9599
 sales.br@tdk-electronics.tdk.com
 www.tdk-electronics.tdk.com/en



TDK-Lambda Corporation
 Tel: +81-3-6778-1113
 www.jp.lambda.tdk.com



TDK-Lambda (China) Electronics Co. Ltd.
 Tel: +86 21 6485-0777
 tlc.powersolutions@tdk.com
 www.lambda.tdk.com.cn



TDK-Lambda Singapore Pte Ltd.
 Tel: +65 6251 7211
 tfs.marketing@tdk.com
 www.sg.lambda.tdk.com



TDK India Private Limited, Power Supply Division
 Tel: +91 80 4039-0660
 mathew.philip@tdk.com
 www.sg.lambda.tdk.com

