

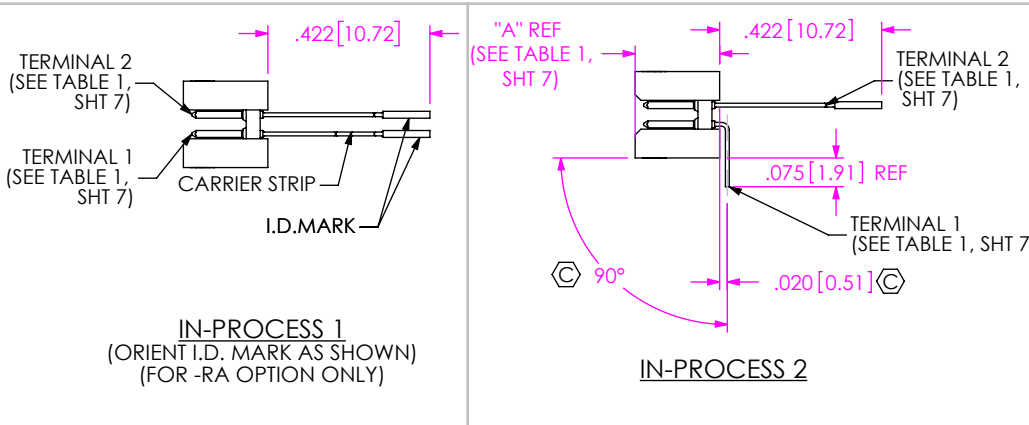

REVISION FX

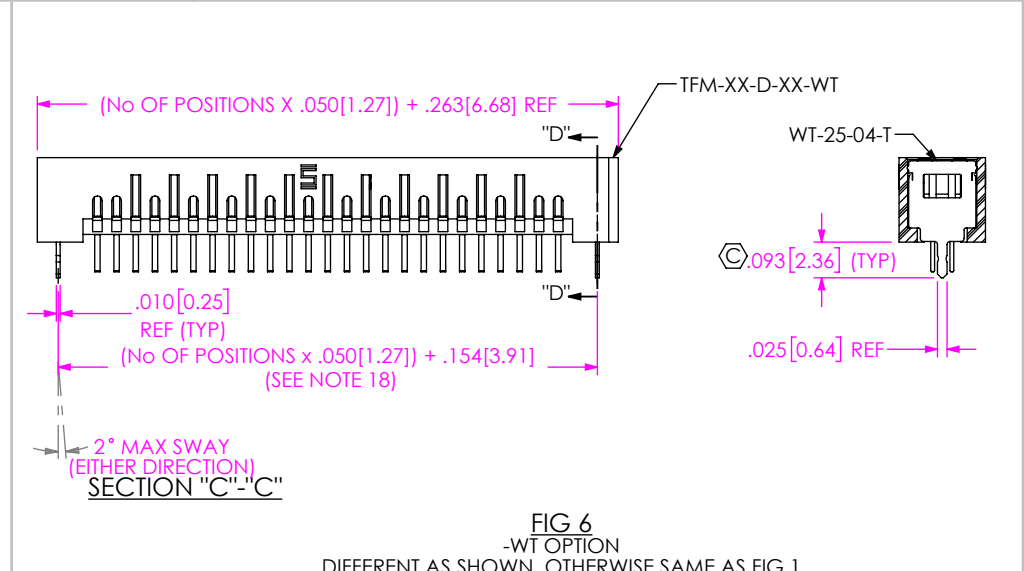
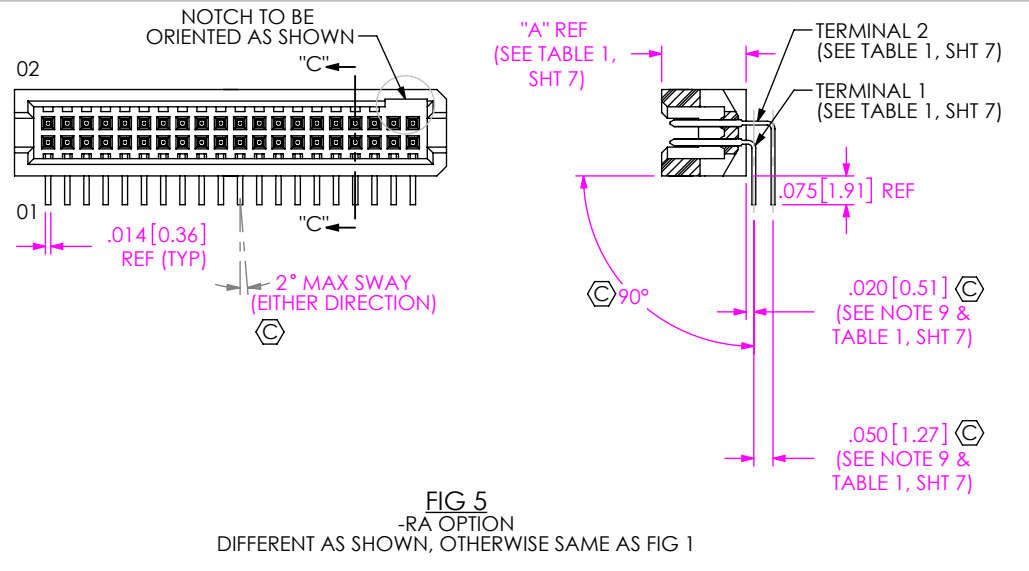
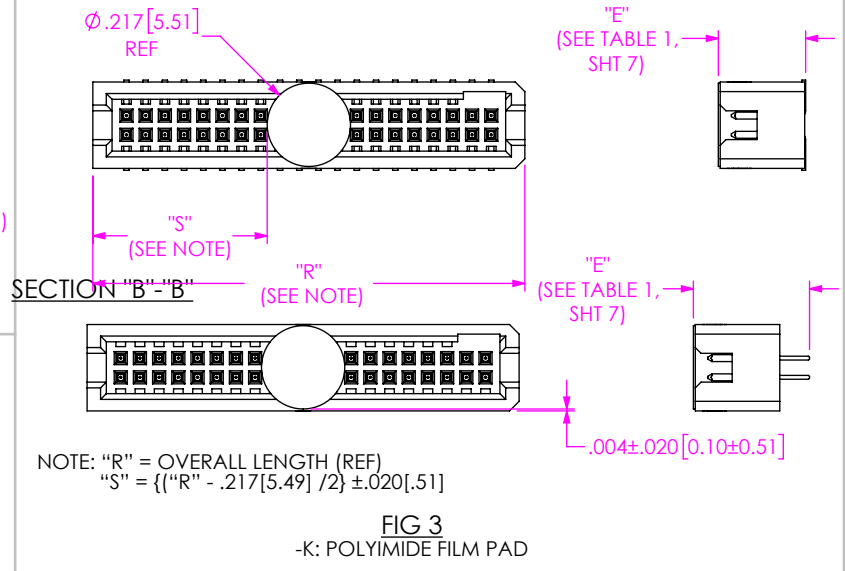
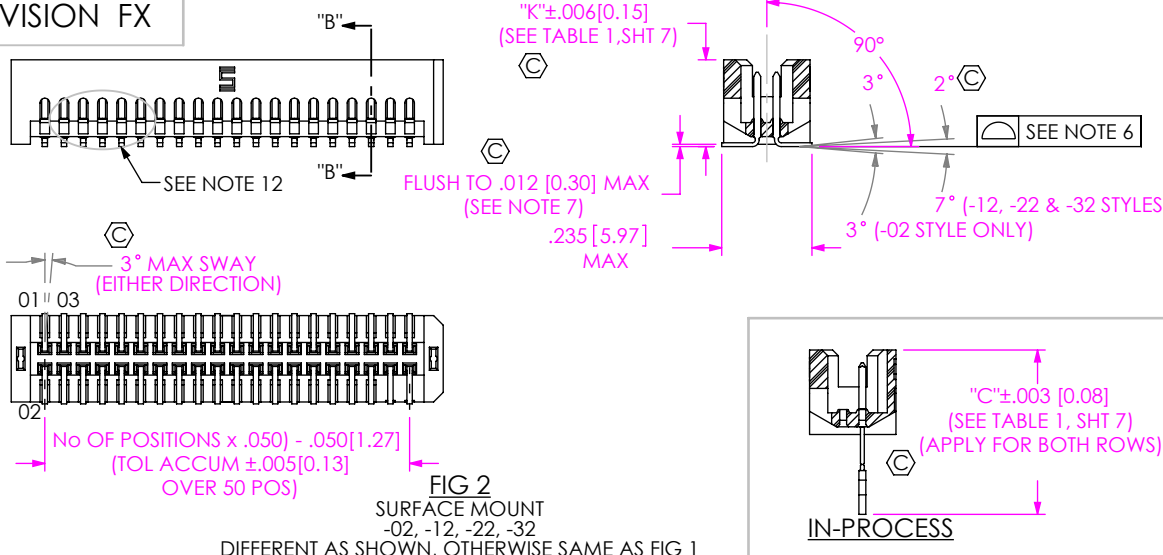

c:\enterprise\dwg\misc\mktg\TFM-1XX-XX-XXX-D-XXX-X-XX-MKT.SLDDRW

**PROPRIETARY NOTE**  
THIS DOCUMENT CONTAINS CONFIDENTIAL AND PROPRIETARY INFORMATION AND ALL DESIGN, MANUFACTURING, REPRODUCTION, USE, PATENT RIGHTS AND SALES RIGHTS ARE EXPRESSLY RESERVED BY SAMTEC, INC. THIS DOCUMENT SHALL NOT BE DISCLOSED, IN WHOLE OR PART, TO ANY UNAUTHORIZED PERSON OR ENTITY NOR REPRODUCED, TRANSFERRED OR INCORPORATED IN ANY OTHER PROJECT IN ANY MANNER WITHOUT THE EXPRESS WRITTEN CONSENT OF SAMTEC, INC.



520 PARK EAST BLVD, NEW ALBANY, IN 47150  
PHONE: 812-944-6733 FAX: 812-948-5047  
e-Mail info@SAMTEC.com code 55322

DO NOT SCALE DRAWING  
SHEET SCALE: 2:1

DESCRIPTION:	.050 X .050 TERMINAL STRIP	
DWG. NO.	TFM-1XX-XX-XXX-D-XXX-X-XX	
BY:	garyp	11/5/2014
		SHEET 2 OF 7

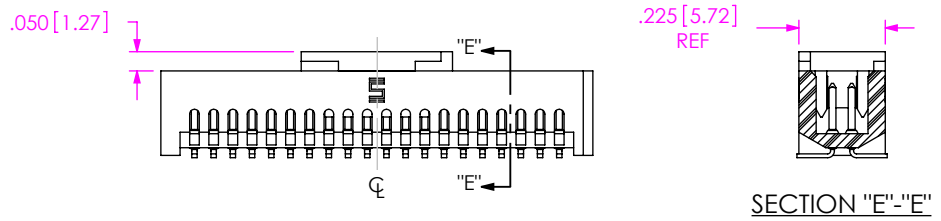
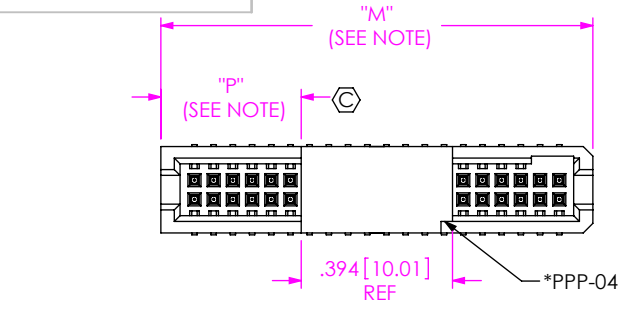

NOTE: "M" = (No. OF POSITIONS X .050[1.27]) + .125[3.18] (REF)  
 WITH -WT "M" = (No. OF POSITIONS X .050[1.27]) + .263[6.68] (REF)  
 "P" = {("M" - .394[10.01]) / 2} ±.020[.51]

\* NOTCH ON PAD TO BE ON SAME END AS THE NOTCH IN THE TFM BODY

FIG 7  
 -P OPTION  
 DIFFERENT AS SHOWN, OTHERWISE SAME AS FIG 1  
 (PAD TO BE POSITIONED ON C.L. AS SHOWN)

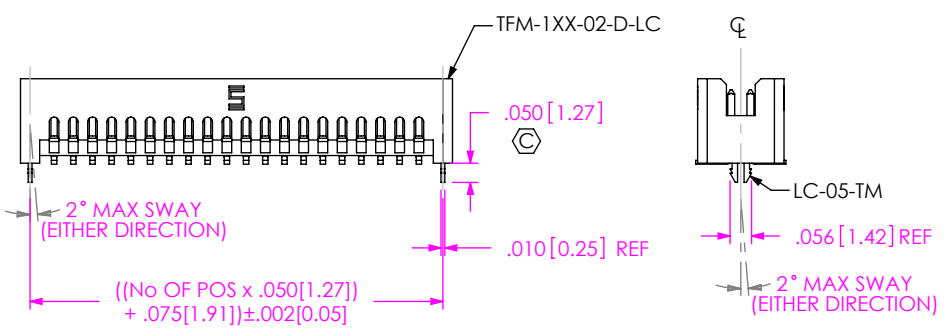

FIG 10  
 -LC OPTION  
 DIFFERENT AS SHOWN, OTHERWISE SAME AS FIG 1  
 (NOT AVAILABLE ON -RA)

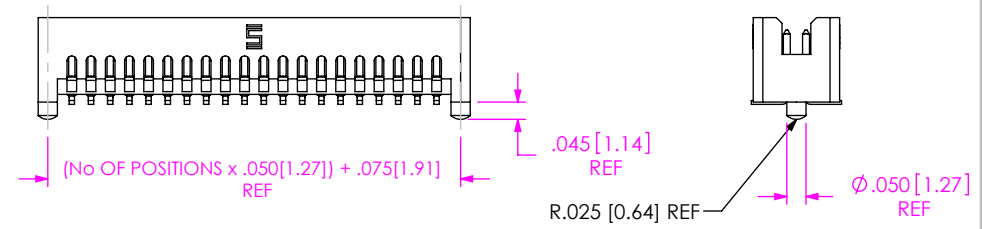

FIG 8  
 -A OPTION  
 DIFFERENT AS SHOWN, OTHERWISE SAME AS FIG 1

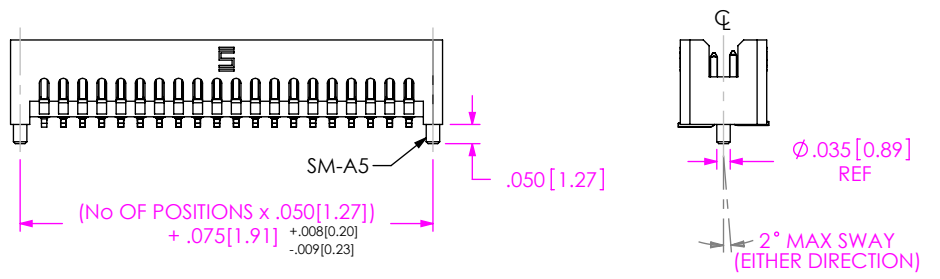

FIG 9  
 -SA OPTION: STAKED ALIGNMENT PIN  
 DIFFERENT AS SHOWN, OTHERWISE SAME AS FIG 1

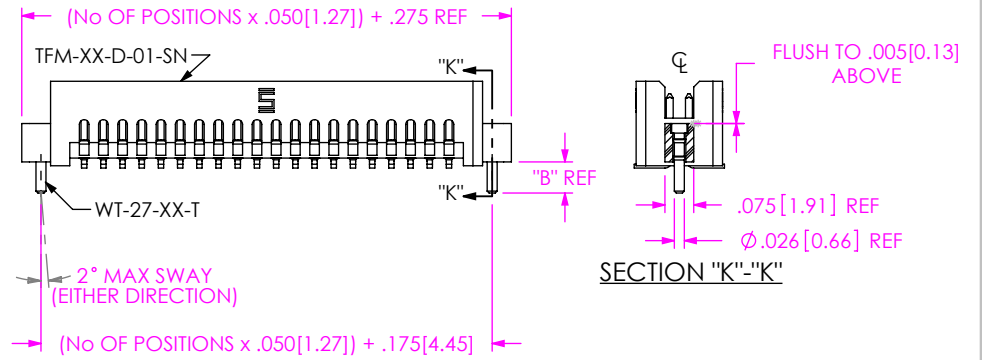

FIG 12  
 -SNX: SOLDER NAIL  
 DIFFERENT AS SHOWN, OTHERWISE SAME AS FIG 1

TABLE 4	
OPTION	"B"
-SN	.081 2.06
-SN2	.115 2.92

c:\enterprise\vauf\DWG\MISC\MKTG\TFM-1XX-XX-XXX-D-XXX-X-XX-MKT.SLDDRW

**PROPRIETARY NOTE**  
 THIS DOCUMENT CONTAINS CONFIDENTIAL AND PROPRIETARY INFORMATION AND ALL DESIGN, MANUFACTURING, REPRODUCTION, USE, PATENT RIGHTS AND SALES RIGHTS ARE EXPRESSLY RESERVED BY SAMTEC, INC. THIS DOCUMENT SHALL NOT BE DISCLOSED, IN WHOLE OR PART, TO ANY UNAUTHORIZED PERSON OR ENTITY NOR REPRODUCED, TRANSFERRED OR INCORPORATED IN ANY OTHER PROJECT IN ANY MANNER WITHOUT THE EXPRESS WRITTEN CONSENT OF SAMTEC, INC.

520 PARK EAST BLVD, NEW ALBANY, IN 47150  
 PHONE: 812-944-6733 FAX: 812-948-5047  
 e-Mail info@SAMTEC.com code 55322

DO NOT SCALE DRAWING  
 SHEET SCALE: 2:1

DESCRIPTION:	.050 X .050 TERMINAL STRIP	
DWG. NO.	TFM-1XX-XX-XXX-D-XXX-X-XX	
BY:	garyp	11/5/2014
		SHEET 3 OF 7

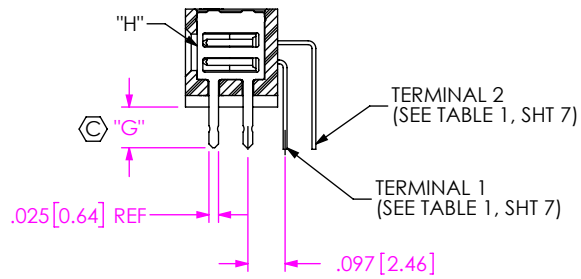
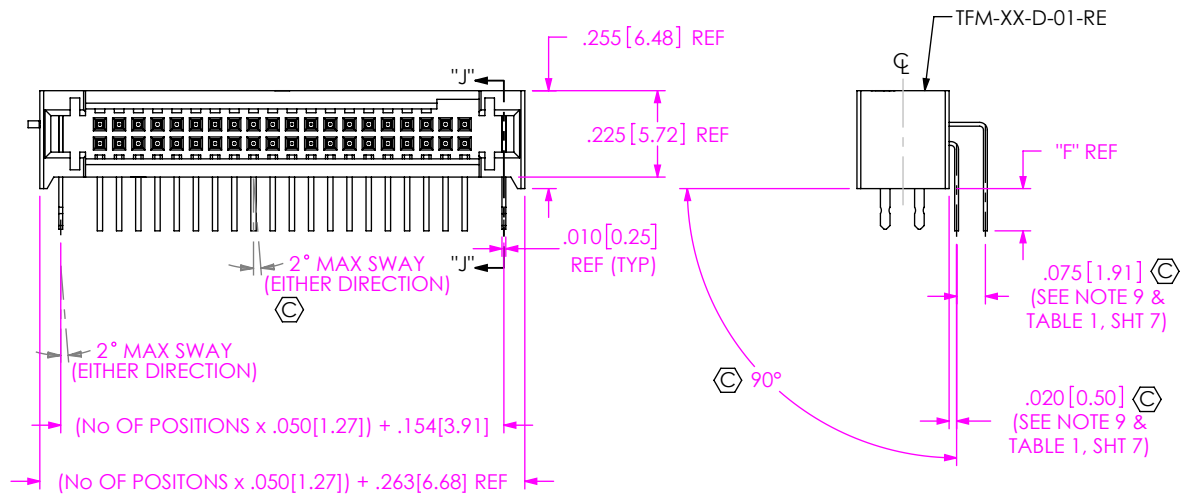
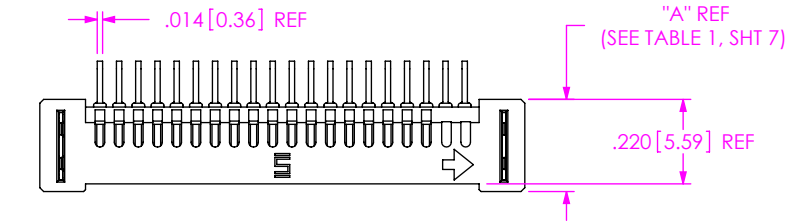

SECTION "J"-"J"

TABLE 3			
LEAD STYLE	"F"	"G"	"H"
-01-RE1	.078 [1.98]	.074 [1.88]	WT-81-01-T
-01-RE2	.110 [2.79]	.106 [2.69]	WT-81-02-T

FIG 11  
-REX: RIGHT ANGLE ELEVATED  
TFM-120-XX-XXX-D-RE2 SHOWN  
DIFFERENT AS SHOWN, OTHERWISE SAME AS FIG 1

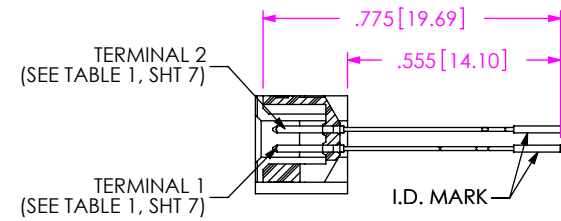

IN-PROCESS 1  
(ORIENT I.D. MARK AS SHOWN)  
(FOR -REX OPTION ONLY)

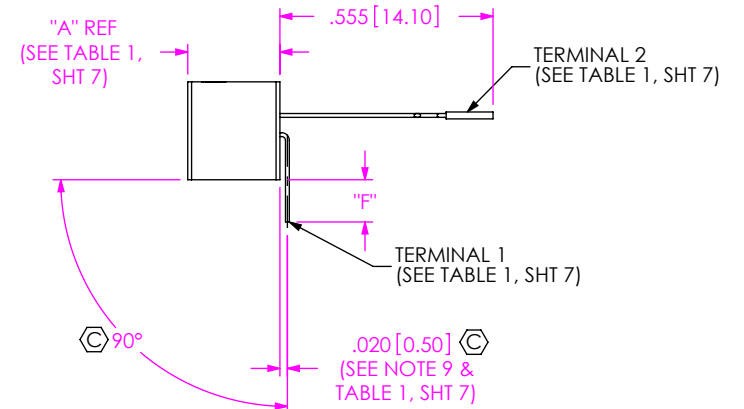

IN-PROCESS 2

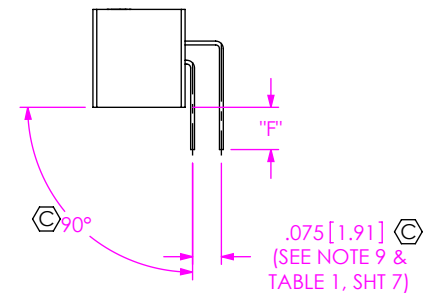

IN-PROCESS 3

c:\enterprisevault\DWG\MISC\MKTG\TFM-1XX-XX-XXX-D-XXX-X-XX-MKT.SLDDRW

**PROPRIETARY NOTE**  
THIS DOCUMENT CONTAINS CONFIDENTIAL AND PROPRIETARY INFORMATION AND ALL DESIGN, MANUFACTURING, REPRODUCTION, USE, PATENT RIGHTS AND SALES RIGHTS ARE EXPRESSLY RESERVED BY SAMTEC, INC. THIS DOCUMENT SHALL NOT BE DISCLOSED, IN WHOLE OR PART, TO ANY UNAUTHORIZED PERSON OR ENTITY NOR REPRODUCED, TRANSFERRED OR INCORPORATED IN ANY OTHER PROJECT IN ANY MANNER WITHOUT THE EXPRESS WRITTEN CONSENT OF SAMTEC, INC.

DO NOT SCALE DRAWING

SHEET SCALE: 2:1



520 PARK EAST BLVD. NEW ALBANY, IN 47150  
PHONE: 812-944-6733 FAX: 812-948-5047  
e-Mail: info@SAMTEC.com code 55322

DESCRIPTION:  
.050 X .050 TERMINAL STRIP

DWG. NO.  
**TFM-1XX-XX-XXX-D-XXX-X-XX**

BY: garyp 11/5/2014 SHEET 4 OF 7

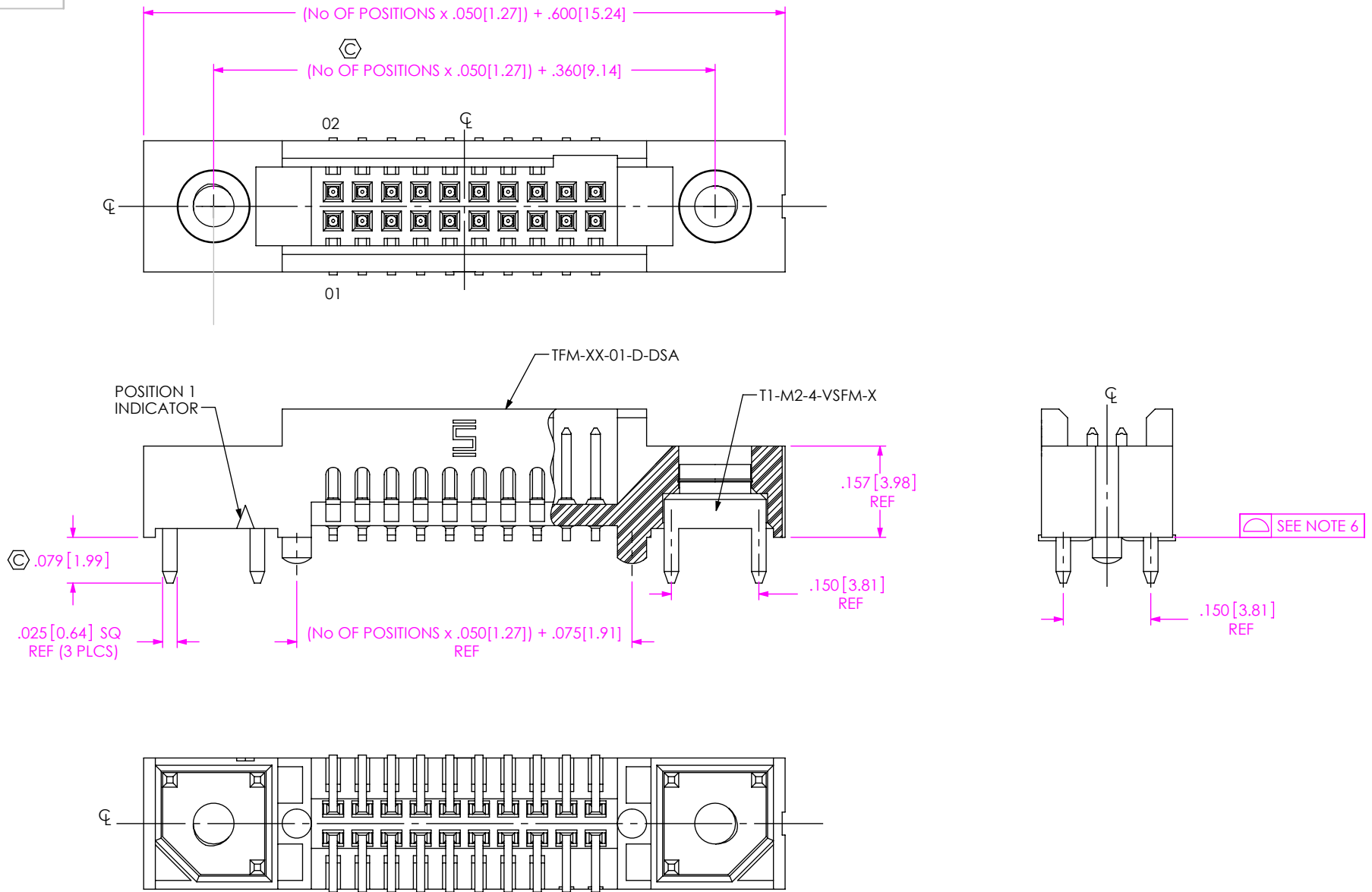

**FIG 18**  
 -DS: DUAL SCREW DOWN  
 TFM-110-02-XXX-D-DS SHOWN  
 DIFFERENT AS SHOWN, OTHERWISE SAME AS FIG 1

c:\enterprise\dwg\MISC\MKTG\TFM-1XX-XX-XXX-D-XXX-X-XX-MKT.SLDDRW

**PROPRIETARY NOTE**  
 THIS DOCUMENT CONTAINS CONFIDENTIAL AND PROPRIETARY INFORMATION AND ALL DESIGN, MANUFACTURING, REPRODUCTION, USE, PATENT RIGHTS AND SALES RIGHTS ARE EXPRESSLY RESERVED BY SAMTEC, INC. THIS DOCUMENT SHALL NOT BE DISCLOSED, IN WHOLE OR PART, TO ANY UNAUTHORIZED PERSON OR ENTITY NOR REPRODUCED, TRANSFERRED OR INCORPORATED IN ANY OTHER PROJECT IN ANY MANNER WITHOUT THE EXPRESS WRITTEN CONSENT OF SAMTEC, INC.

DO NOT SCALE DRAWING

SHEET SCALE: 2:1



520 PARK EAST BLVD, NEW ALBANY, IN 47150  
 PHONE: 812-944-6733 FAX: 812-948-5047  
 e-Mail: info@SAMTEC.com code 55322

DESCRIPTION:	.050 X .050 TERMINAL STRIP	
DWG. NO.	TFM-1XX-XX-XXX-D-XXX-X-XX	
BY:	garyp	11/5/2014
		SHEET 5 OF 7

# PARTS TO BE PACKAGED IN TUBES AS SHOWN

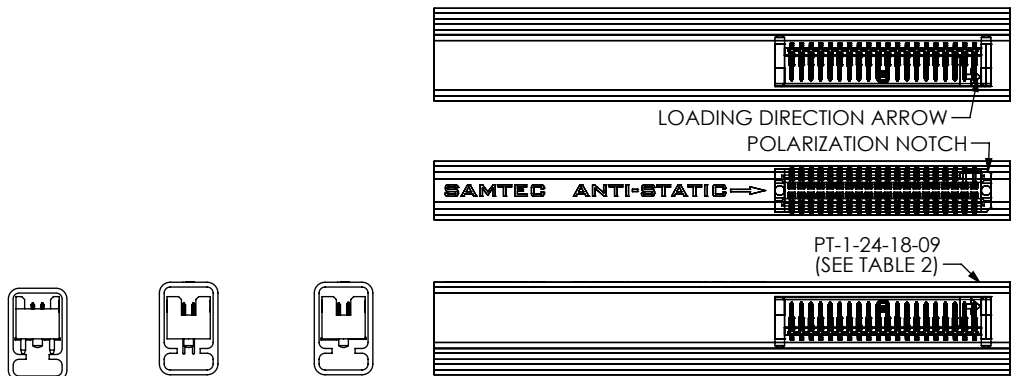

FIG 13  
PT-1-24-18-09

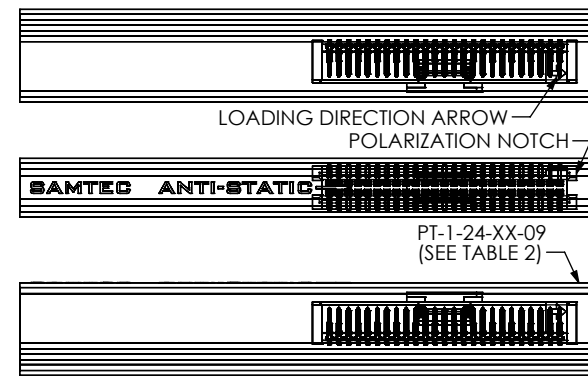

FIG 14  
PT-1-24-XX-09

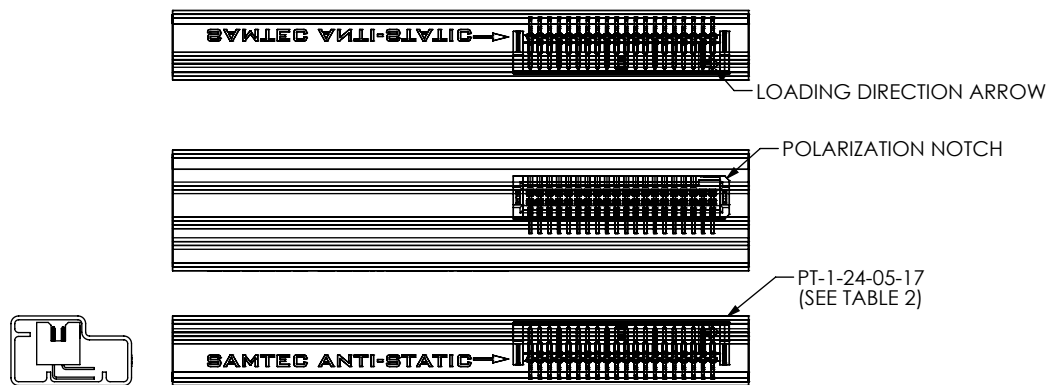

FIG 15  
PT-1-24-05-17

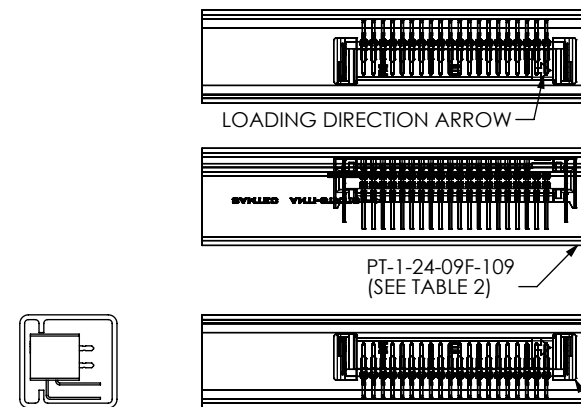

FIG 16  
PT-1-24-09F-109

TABLE 2

LEAD STYLE	PACKAGING TUBE	PLUG
-RA (ALL LEAD STYLES)	PT-1-24-05-17	TP-07
-REX	PT-1-24-09F-109	TP-29
-01, -01-A, -01-LC, -01-WT, -01-A-K, -02, -02-A, -02-A-K, -02-LC, -02-SN	PT-FTSH002-DV-A-P-M	TP-03
-12 (ALL OPTIONS), -22-K, -22, -22-A, -22-A-K, -22-LC, -22-LC-K	PT-1-24-04-09	TP-07
-02-A-P, -02-K, -02-LC-K, -02-LC-P, -02-P, -02-WT, -02-WT-K	PT-1-24-18-09	TP-09
-01-K, -01-P, -01-LC-P, -01-A-P, -01-WT-P, -01-WT-K, -11, -11-A, -11-LC, -11-K, -11-LC-K, -11-A-K		
-02-SN2-P, -02-SN2, -03 (ALL OPTIONS)		
-13, -13-A, -13-LC, -13-K, -13-LC-K, -13-A-K	PT-1-24-02-09	TP-07
-01-DS, -02-DS		
-31-A-K, -31-A-P, -31-LC-P, -31-P, -32, -32-K, -32-A, -32-A-K,		
-32-A-P, -32-LC-K, -32-LC-P, -32-P, -32-LC	PT-1-24-05-09	TP-07
-31, -21-P, -22-P, -31-LC, -21-A-P, -21-LC-P, -22-LC-P, -22-A-P, -31-A,		
-13-P, -13-LC-P, -13-A-P, -21, -23, -23-P, -23-A-P,		
-11-P, -11-LC-P, -11-A-P, -21-K, -21-A, -21-LC, -21-A-K, -21-LC-K,	PT-1-24-20-09	TP-07
-23-K, -23-A, -23-A-K, -23-LC, -23-LC-K		

NOTE:

1. PARTS TO BE PACKAGED WITH THE LOADING DIRECTION ARROW POINTED IN SAME DIRECTION AS THE ARROW ON TUBE.
2. A PART WITH -SA OPTION WILL USE THE SAME TUBE AS THE CORRESPONDING PART WITH THE -A OPTION

c:\enterprise\ault\DWG\MISC\MKTG\TFM-1XX-XX-XXX-D-XXX-X-XX-MKT.SLDRW

**PROPRIETARY NOTE**  
 THIS DOCUMENT CONTAINS CONFIDENTIAL AND PROPRIETARY INFORMATION AND ALL DESIGN, MANUFACTURING, REPRODUCTION, USE, PATENT RIGHTS AND SALES RIGHTS ARE EXPRESSLY RESERVED BY SAMTEC, INC. THIS DOCUMENT SHALL NOT BE DISCLOSED, IN WHOLE OR PART, TO ANY UNAUTHORIZED PERSON OR ENTITY NOR REPRODUCED, TRANSFERRED OR INCORPORATED IN ANY OTHER PROJECT IN ANY MANNER WITHOUT THE EXPRESS WRITTEN CONSENT OF SAMTEC, INC.

DO NOT SCALE DRAWING  
 SHEET SCALE: 2:1



520 PARK EAST BLVD, NEW ALBANY, IN 47150  
 PHONE: 812-944-6733 FAX: 812-948-5047  
 e-Mail: info@SAMTEC.com code 55322

DESCRIPTION:  
 .050 X .050 TERMINAL STRIP  
 DWG. NO.  
**TFM-1XX-XX-XXX-D-XXX-X-XX**  
 BY: garyp 11/5/2014 SHEET 6 OF 7

TABLE 1

LEAD STYLE	BODY	"A"	TERMINAL 1	TERMINAL 2	"C"	"D"	"E"	"J"	"K"
-01	TFM-XX-D-01-XX	.2200 [5.588]	T-1R16-01-XX-2	N/A	.428 [10.87]	.131 [3.33]	.303 [7.70]	.078 [1.98]	N/A
-11	TFM-XX-D-02-XX	.2900 [7.366]	T-1R20-03-XX	N/A	.645 [16.38]	.139 [3.53]	.375 [9.53]	.080 [2.03]	N/A
-21	TFM-XX-D-03-XX	.3600 [9.144]	T-1R20-04-XX	N/A	.645 [16.38]	.139 [3.53]	N/A	.080 [2.03]	N/A
-31	TFM-XX-D-04-XX	.4350 [11.049]	T-1R20-02-XX	N/A	.645 [16.38]	.139 [3.53]	.520 [13.21]	.080 [2.03]	N/A
-02	TFM-XX-D-01-XX	.2200 [5.588]	T-1R16-01-XX-2	N/A	.428 [10.87]	.131 [3.33]	.231 [5.87]	N/A	.226 [5.74]
-12	TFM-XX-D-02-XX	.2900 [7.366]	T-1R20-03-XX	N/A	.645 [16.38]	.139 [3.53]	.301 [7.65]	N/A	.296 [7.52]
-22	TFM-XX-D-03-XX	.3600 [9.144]	T-1R20-04-XX	N/A	.645 [16.38]	.139 [3.53]	.371 [9.42]	N/A	.366 [9.30]
-32	TFM-XX-D-04-XX	.4350 [11.049]	T-1R20-02-XX	N/A	.645 [16.38]	.139 [3.53]	.446 [11.33]	N/A	.441 [11.20]
-01-RA	TFM-XX-D-01-XX	.2200 [5.588]	T-1R16-02-XX	T-1R16-03-XX	N/A	.142 [3.59]	N/A	N/A	N/A
-01-RE1	TFM-XX-D-01-RE	.2400 [6.096]	T-1R16-06-XX	T-1R16-07-XX	N/A	.139 [3.52]	N/A	N/A	N/A
-01-RE2	TFM-XX-D-01-RE	.2400 [6.096]	T-1R16-08-XX	T-1R16-09-XX	N/A	.139 [3.52]	N/A	N/A	N/A
-03	TFM-XX-D-01-XX	.2200 [5.588]	T-1R16-10-XX	N/A	.645 [16.38]	.139 [3.53]	.336 [8.53]	.111 [2.82]	N/A
-13	TFM-XX-D-02-XX	.2900 [7.366]	T-1R20-05-XX	N/A	.645 [16.38]	.139 [3.53]	.406 [10.31]	.111 [2.82]	N/A
-23	TFM-XX-D-03-XX	.3600 [9.144]	T-1R20-06-XX	N/A	.645 [16.38]	.139 [3.53]	.476 [12.09]	.111 [2.82]	N/A

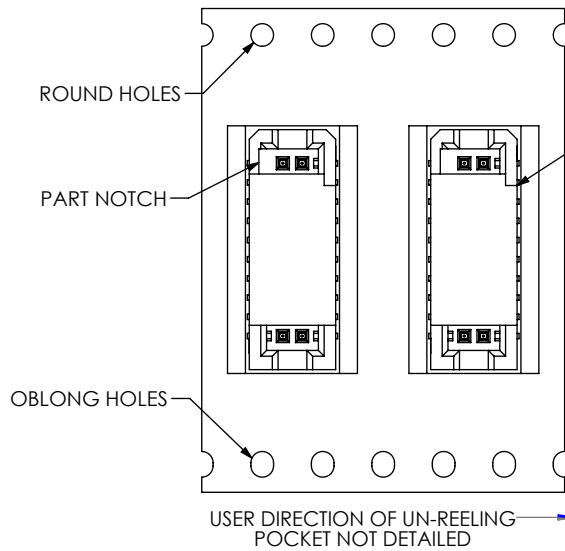

FIG 4  
-TR: TAPE AND REEL  
(SEE NOTE 14)

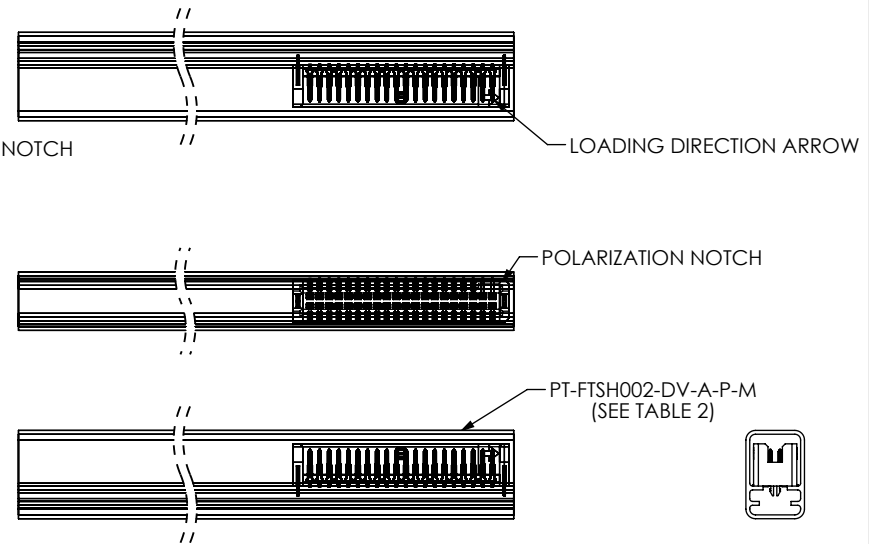

FIG 17  
PT-FTSH002-DV-A-P-M

c:\enterprisevault\DWG\MISC\MKTG\TFM-1XX-XX-XXX-D-XXX-X-XX-MKT.SLDDRW

**PROPRIETARY NOTE**  
THIS DOCUMENT CONTAINS CONFIDENTIAL AND PROPRIETARY INFORMATION AND ALL DESIGN, MANUFACTURING, REPRODUCTION, USE, PATENT RIGHTS AND SALES RIGHTS ARE EXPRESSLY RESERVED BY SAMTEC, INC. THIS DOCUMENT SHALL NOT BE DISCLOSED, IN WHOLE OR PART, TO ANY UNAUTHORIZED PERSON OR ENTITY NOR REPRODUCED, TRANSFERRED OR INCORPORATED IN ANY OTHER PROJECT IN ANY MANNER WITHOUT THE EXPRESS WRITTEN CONSENT OF SAMTEC, INC.

DO NOT SCALE DRAWING

SHEET SCALE: 2:1



520 PARK EAST BLVD, NEW ALBANY, IN 47150  
PHONE: 812-944-6733 FAX: 812-948-5047  
e-Mail info@SAMTEC.com code 55322

DESCRIPTION:  
.050 X .050 TERMINAL STRIP

DWG. NO.  
**TFM-1XX-XX-XXX-D-XXX-X-XX**

BY: garyp 11/5/2014 SHEET 7 OF 7