

ON Semiconductor

Is Now

onsemi™

To learn more about onsemi™, please visit our website at
www.onsemi.com

onsemi and **onsemi** and other names, marks, and brands are registered and/or common law trademarks of Semiconductor Components Industries, LLC dba "**onsemi**" or its affiliates and/or subsidiaries in the United States and/or other countries. **onsemi** owns the rights to a number of patents, trademarks, copyrights, trade secrets, and other intellectual property. A listing of **onsemi** product/patent coverage may be accessed at www.onsemi.com/site/pdf/Patent-Marking.pdf. **onsemi** reserves the right to make changes at any time to any products or information herein, without notice. The information herein is provided "as-is" and **onsemi** makes no warranty, representation or guarantee regarding the accuracy of the information, product features, availability, functionality, or suitability of its products for any particular purpose, nor does **onsemi** assume any liability arising out of the application or use of any product or circuit, and specifically disclaims any and all liability, including without limitation special, consequential or incidental damages. Buyer is responsible for its products and applications using **onsemi** products, including compliance with all laws, regulations and safety requirements or standards, regardless of any support or applications information provided by **onsemi**. "Typical" parameters which may be provided in **onsemi** data sheets and/or specifications can and do vary in different applications and actual performance may vary over time. All operating parameters, including "Typicals" must be validated for each customer application by customer's technical experts. **onsemi** does not convey any license under any of its intellectual property rights nor the rights of others. **onsemi** products are not designed, intended, or authorized for use as a critical component in life support systems or any FDA Class 3 medical devices or medical devices with a same or similar classification in a foreign jurisdiction or any devices intended for implantation in the human body. Should Buyer purchase or use **onsemi** products for any such unintended or unauthorized application, Buyer shall indemnify and hold **onsemi** and its officers, employees, subsidiaries, affiliates, and distributors harmless against all claims, costs, damages, and expenses, and reasonable attorney fees arising out of, directly or indirectly, any claim of personal injury or death associated with such unintended or unauthorized use, even if such claim alleges that **onsemi** was negligent regarding the design or manufacture of the part. **onsemi** is an Equal Opportunity/Affirmative Action Employer. This literature is subject to all applicable copyright laws and is not for resale in any manner. Other names and brands may be claimed as the property of others.

NCS325, NCS2325, NCS4325

50 μV Offset, 0.25 $\mu\text{V}/^\circ\text{C}$, 35 μA , Zero-Drift Operational Amplifier

The NCS325, NCS2325 and NCS4325 are CMOS operational amplifiers providing precision performance. The Zero-Drift architecture allows for continuous auto-calibration, which provides very low offset, near-zero drift over time and temperature, and near flat 1/f noise at only 35 μA (max) quiescent current. These benefits make these devices ideal for precision DC applications. These op amps provide rail-to-rail input and output performance and are optimized for low voltage operation as low as 1.8 V and up to 5.5 V. The single channel NCS325 is available in the space-saving SOT23-5 package. The dual channel NCS2325 is available in Micro8, SOIC-8, and DFN-8. The quad channel NCS4325 is available in SOIC-14.

Features

- Low Offset Voltage: 14 μV typ, 50 μV max at 25°C for NCS325
- Zero Drift: 0.25 $\mu\text{V}/^\circ\text{C}$ max
- Low Noise: 1 μVpp , 0.1 Hz to 10 Hz
- Quiescent Current: 21 μA typ, 35 μA max at 25°C
- Supply Voltage: 1.8 V to 5.5 V
- Rail-to-Rail Input and Output
- Internal EMI Filtering
- These Devices are Pb-Free, Halogen Free/BFR Free and are RoHS Compliant

Typical Applications

- Battery Powered Instruments
- Temperature Measurements
- Transducer Applications
- Electronic Scales
- Medical Instrumentation
- Current Sensing



ON Semiconductor®

www.onsemi.com

MARKING DIAGRAMS

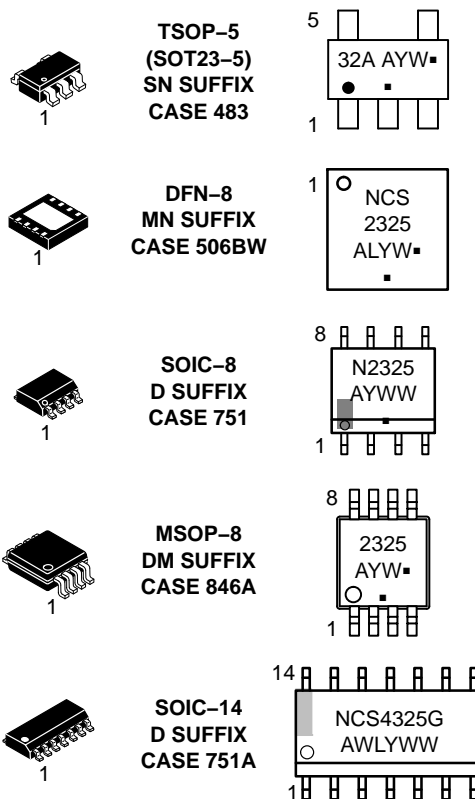

A = Assembly Location
Y = Year
WL = Wafer Lot
W or WW = Work Week
G or ■ = Pb-Free Package

(Note: Microdot may be in either location)

ORDERING INFORMATION

See detailed ordering and shipping information on page 2 of this data sheet.

This document contains information on some products that are still under development. ON Semiconductor reserves the right to change or discontinue these products without notice.

NCS325, NCS2325, NCS4325

PIN CONNECTIONS

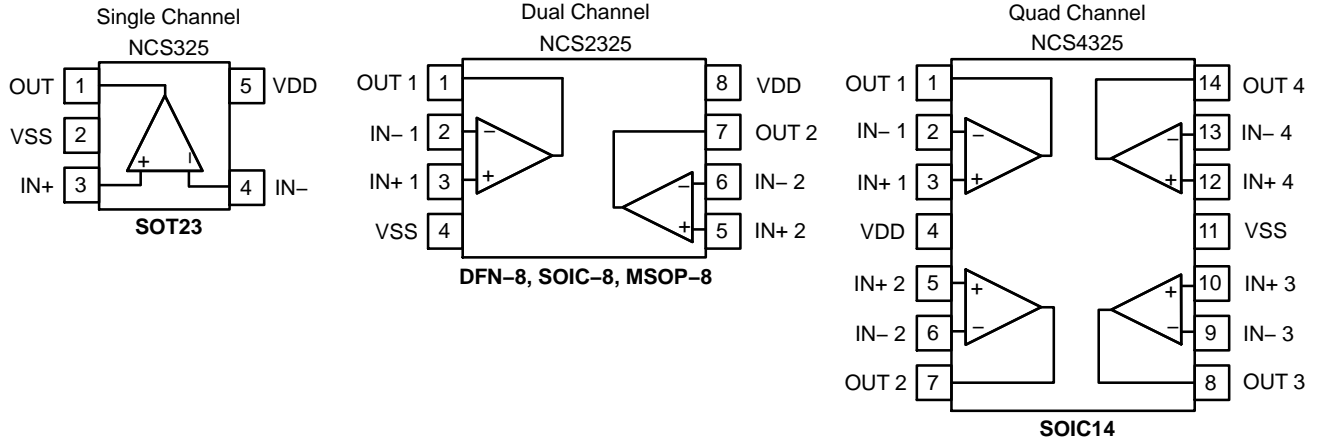

ORDERING INFORMATION

Configuration	Device	Package	Shipping†
Single	NCS325SN2T1G	SOT23-5 / TSOP-5	3000 / Tape & Reel
Dual	NCS2325MNTXG* (In Development)	DFN8	3000 / Tape & Reel
	NCS2325DR2G	SOIC-8	3000 / Tape & Reel
	NCS2325DMR2G	Micro8 / MSOP-8	4000 / Tape & Reel
Quad	NCS4325DR2G	SOIC-14	2500 / Tape & Reel

†For information on tape and reel specifications, including part orientation and tape sizes, please refer to our Tape and Reel Packaging Specifications Brochure, BRD8011/D.

*Contact local sales office for more information

NCS325, NCS2325, NCS4325

ABSOLUTE MAXIMUM RATINGS Over operating free-air temperature, unless otherwise stated.

Parameter	Rating	Unit
Supply Voltage	6	V

INPUT AND OUTPUT PINS

Input Voltage (Note 1)	$(V_{SS}) - 0.3$ to $(V_{DD}) + 0.3$	V
Input Current (Note 1)	± 10	mA
Output Short Circuit Current (Note 2)	Continuous	

TEMPERATURE

Operating Temperature	-40 to +150	°C
Storage Temperature	-65 to +150	°C
Junction Temperature	+150	°C

ESD RATINGS (Note 3)

Human Body Model (HBM)	4000	V
Machine Model (MM)	200	V

OTHER RATINGS

Latch-up Current (Note 4)	100	mA
MSL	Level 1	

Stresses exceeding those listed in the Maximum Ratings table may damage the device. If any of these limits are exceeded, device functionality should not be assumed, damage may occur and reliability may be affected.

- Input terminals are diode-clamped to the power-supply rails. Input signals that can swing more than 0.3 V beyond the supply rails should be current limited to 10 mA or less
- Short-circuit to ground.
- This device series incorporates ESD protection and is tested by the following methods:
ESD Human Body Model tested per AEC-Q100-002 (JEDEC standard: JESD22-A114)
ESD Machine Model tested per AEC-Q100-003 (JEDEC standard: JESD22-A115)
- Latch-up Current tested per JEDEC standard: JESD78.

THERMAL INFORMATION

Thermal Metric	Symbol	Package	Value	Unit
Junction to Ambient (Note 5)	θ_{JA}	SOT23-5 / TSOP-5	235	°C/W
		Micro8 / MSOP-8	298	
		SOIC-8	250	
		DFN-8	130	
		SOIC-14	216	

- As mounted on an 80x80x1.5 mm FR4 PCB with 650 mm² and 2 oz (0.034 mm) thick copper heat spreader. Following JEDEC JESD/EIA 51.1, 51.2, 51.3 test guidelines

OPERATING CONDITIONS

Parameter	Symbol	Range	Unit
Supply Voltage ($V_{DD} - V_{SS}$)	V_S	1.8 to 5.5	V
Specified Operating Range	T_A	-40 to 125	°C
Input Common Mode Voltage Range	V_{ICMR}	$V_{SS}-0.1$ to $V_{DD}+0.1$	V

Functional operation above the stresses listed in the Recommended Operating Ranges is not implied. Extended exposure to stresses beyond the Recommended Operating Ranges limits may affect device reliability.

NCS325, NCS2325, NCS4325

ELECTRICAL CHARACTERISTICS: $V_S = 1.8\text{ V}$ to 5.5 V

At $T_A = +25^\circ\text{C}$, $R_L = 10\text{ k}\Omega$ connected to midsupply, $V_{CM} = V_{OUT} = \text{midsupply}$, unless otherwise noted.

Boldface limits apply over the specified temperature range, $T_A = -40^\circ\text{C}$ to 125°C , guaranteed by characterization and/or design.

Parameter	Symbol	Conditions	Min	Typ	Max	Unit
-----------	--------	------------	-----	-----	-----	------

INPUT CHARACTERISTICS

Offset Voltage	V_{OS}	NCS325	$V_S = +5\text{ V}$		14	50	μV
		NCS2325, NCS4325	$V_S = +5\text{ V}$		14	75	
Offset Voltage Drift vs Temp	$\Delta V_{OS}/\Delta T$	$T_A = -40^\circ\text{C}$ to 125°C			0.02	0.25	$\mu\text{V}/^\circ\text{C}$
Input Bias Current	I_{IB}				± 50		pA
Input Offset Current	I_{OS}				± 100		pA
Common Mode Rejection Ratio	CMRR	NCS325	$V_{SS}+0.3 < V_{CM} < V_{DD} - 0.3$, $V_S = 1.8\text{ V}$	85	108		dB
			$V_{SS}+0.3 < V_{CM} < V_{DD} - 0.3$, $V_S = 5.5\text{ V}$	90	110		
		NCS2325, NCS4325	$V_{SS}+0.3 < V_{CM} < V_{DD} - 0.3$, $V_S = 5\text{ V}$	90	110		
			$V_{SS}-0.1 < V_{CM} < V_{DD} + 0.1$, $V_S = 1.8\text{ V}$		80		
			$V_{SS}-0.1 < V_{CM} < V_{DD} + 0.1$, $V_S = 5.5\text{ V}$		92		
Input Resistance	R_{IN}				15		$\text{G}\Omega$
Input Capacitance	C_{IN}	NCS325	Differential		1.8		pF
			Common Mode		3.5		pF
		NCS2325, NCS4325	Differential		4.1		pF
			Common Mode		8.0		pF

OUTPUT CHARACTERISTICS

Output Voltage High	V_{OH}	Output swing within V_{DD}		12	100	mV
Output Voltage Low	V_{OL}	Output swing within V_{SS}		8	100	mV
Short Circuit Current	I_{SC}			± 5		mA
Open Loop Output Impedance	Z_{out-OL}	$f = 350\text{ kHz}$, $I_O = 0\text{ mA}$, $V_S = 1.8\text{ V}$		1.4		$\text{k}\Omega$
		$f = 350\text{ kHz}$, $I_O = 0\text{ mA}$, $V_S = 5.5\text{ V}$		2.7		
Capacitive Load Drive	C_L			See Figure		

NOISE PERFORMANCE

Voltage Noise Density	e_N	$f_{IN} = 1\text{ kHz}$		100		$\text{nV} / \sqrt{\text{Hz}}$
Voltage Noise	e_{P-P}	$f_{IN} = 0.01\text{ Hz}$ to 1 Hz		0.3		μV_{PP}
		$f_{IN} = 0.1\text{ Hz}$ to 10 Hz		1		μV_{PP}
Current Noise Density	i_N	$f_{IN} = 10\text{ Hz}$		0.3		$\text{pA} / \sqrt{\text{Hz}}$

DYNAMIC PERFORMANCE

Open Loop Voltage Gain	A_{VOL}	$R_L = 10\text{ k}\Omega$, $V_S = 5.5\text{ V}$				114		dB
Gain Bandwidth Product	GBWP	NCS325	$C_L = 100\text{ pF}$, $R_L = 10\text{ k}\Omega$		350			kHz
		NCS2325, NCS4325	$C_L = 100\text{ pF}$, $R_L = 10\text{ k}\Omega$		270			
Phase Margin	ϕ_M	$C_L = 100\text{ pF}$				60		$^\circ$
Gain Margin	A_M	$C_L = 100\text{ pF}$				20		dB
Slew Rate	SR	$G = +1$, $C_L = 100\text{ pF}$, $V_S = 1.8\text{ V}$				0.10		$\text{V}/\mu\text{s}$
		$G = +1$, $C_L = 100\text{ pF}$, $V_S = 5.5\text{ V}$				0.16		

POWER SUPPLY

Power Supply Rejection Ratio	PSRR		100	107		dB		
		$T_A = -40^\circ\text{C}$ to 125°C	95					
Turn-on Time	t_{ON}	$V_S = 5\text{ V}$				100	μs	
Quiescent Current	I_Q	No load				21	35	μA

Product parametric performance is indicated in the Electrical Characteristics for the listed test conditions, unless otherwise noted. Product performance may not be indicated by the Electrical Characteristics if operated under different conditions.

NCS325, NCS2325, NCS4325

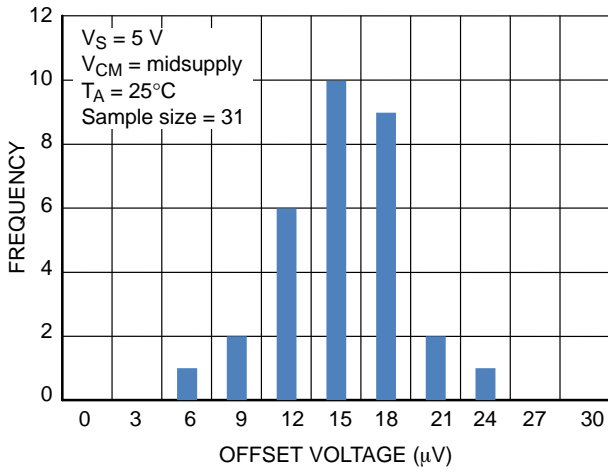

Figure 1. Offset Voltage Distribution

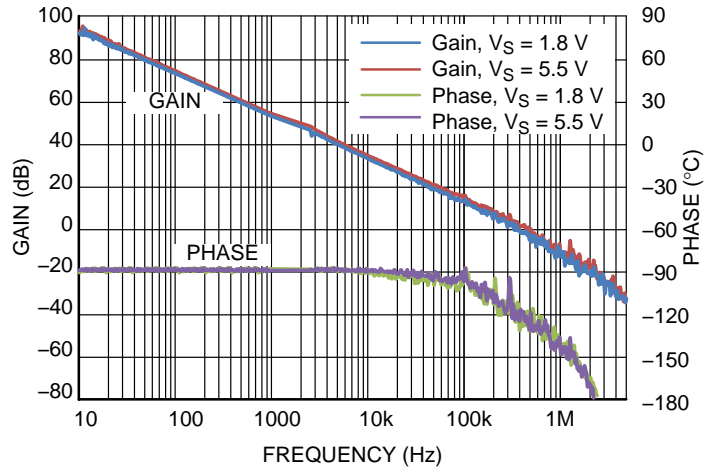

Figure 2. Gain and Phase vs. Frequency

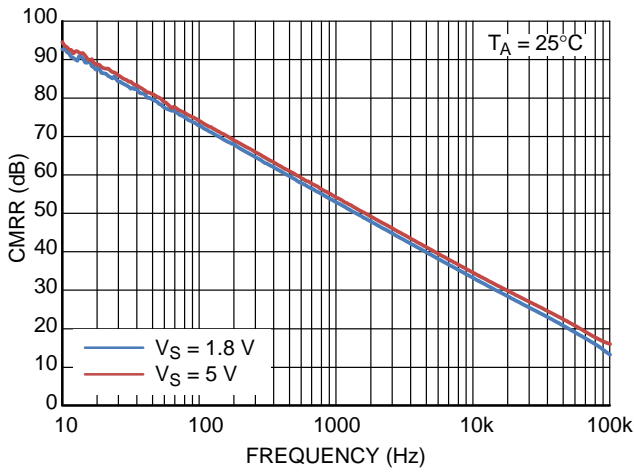

Figure 3. CMRR vs. Frequency

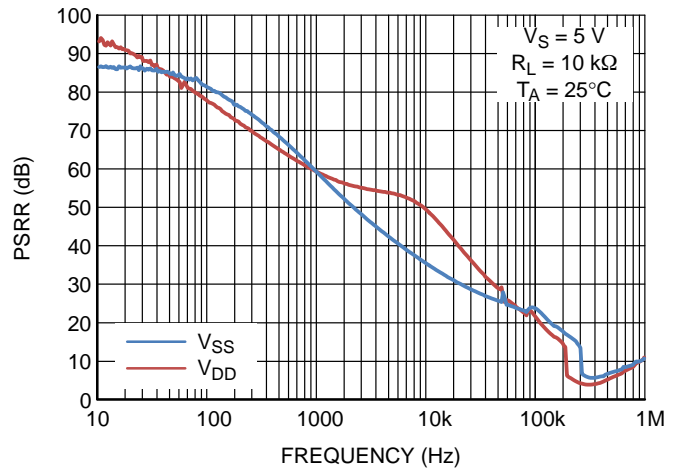

Figure 4. PSRR vs. Frequency

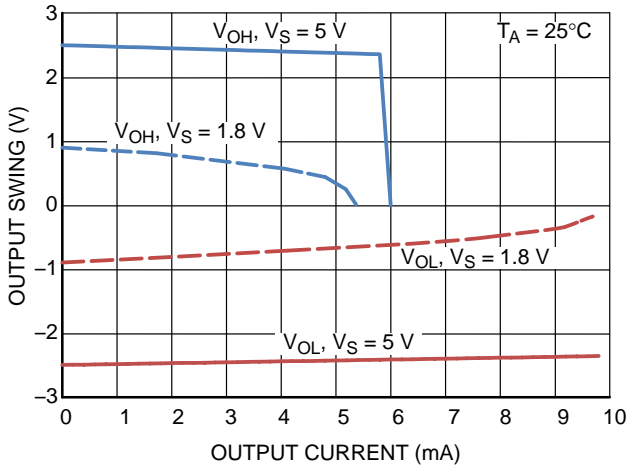

Figure 5. Output Voltage Swing vs. Output Current

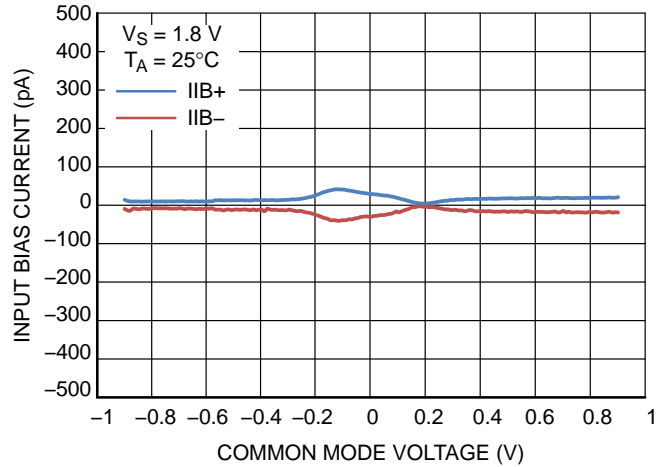

Figure 6. Input Bias Current vs. Common Mode Voltage, $V_S = 1.8\text{ V}$

NCS325, NCS2325, NCS4325

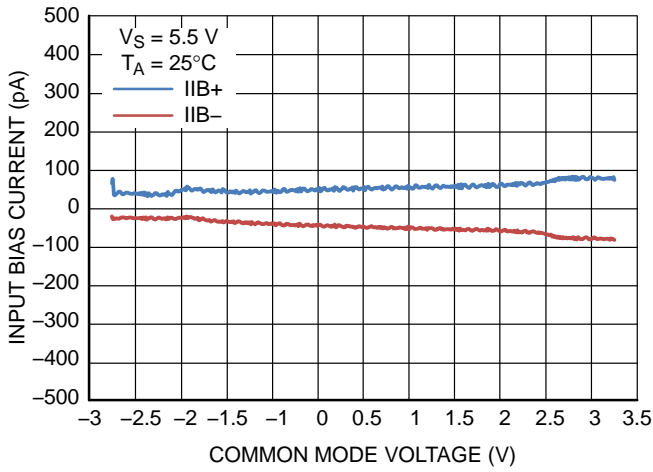

Figure 7. Input Bias Current vs. Common Mode Voltage, $V_S = 5.5\text{ V}$

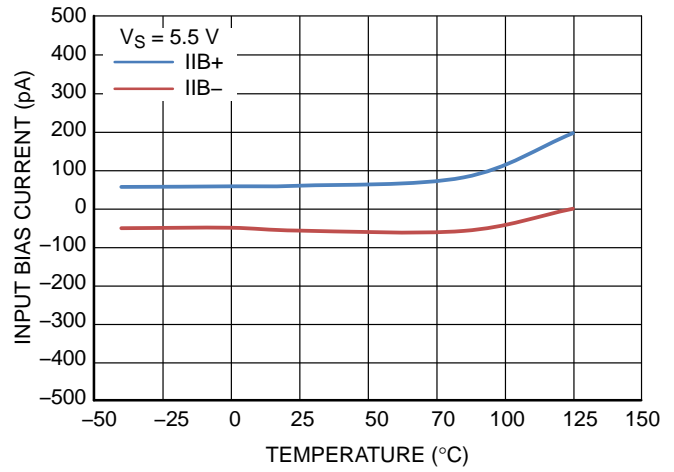

Figure 8. Input Bias Current vs. Temperature

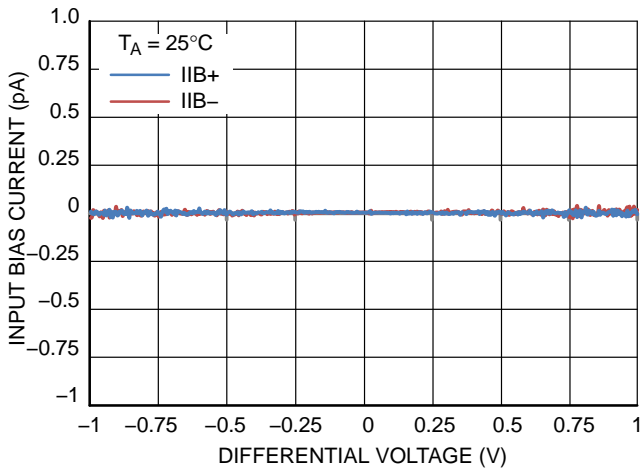

Figure 9. Input Bias Current vs. Input Differential Voltage

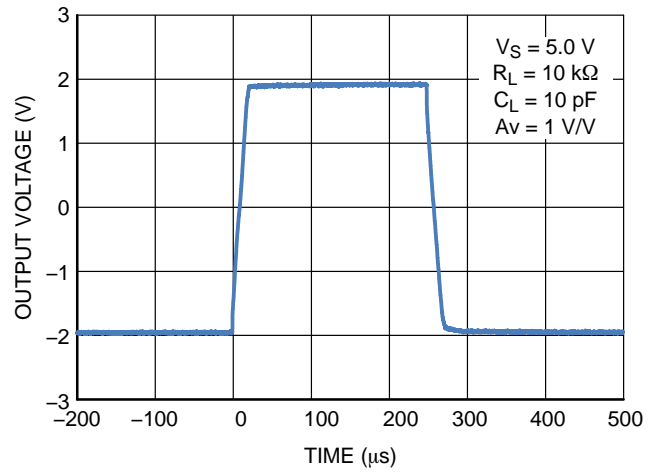

Figure 10. Large Signal Step Response

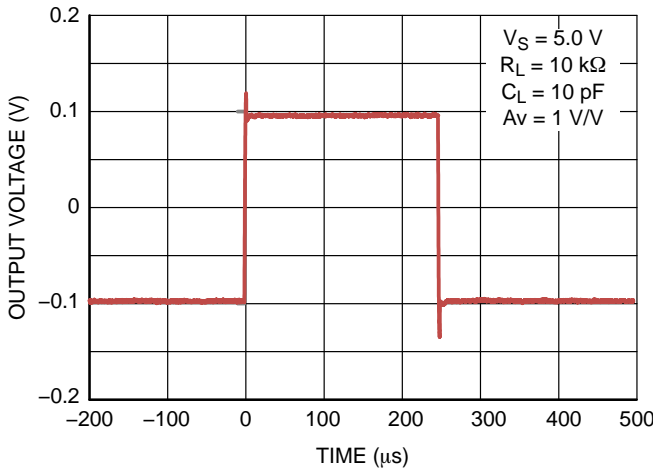

Figure 11. Small Signal Step Response

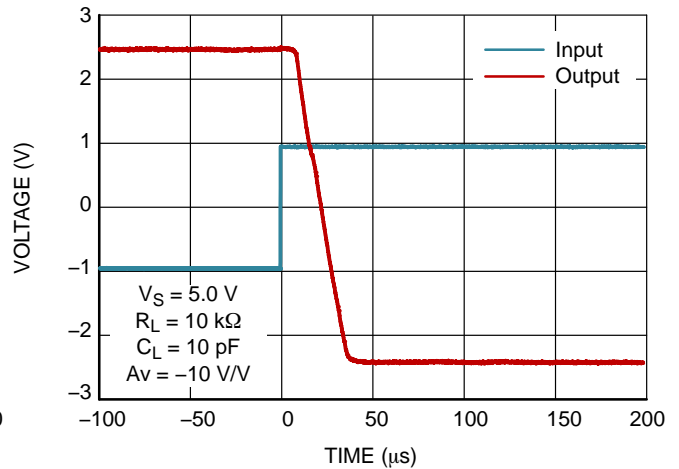

Figure 12. Positive Over Voltage Recovery

NCS325, NCS2325, NCS4325

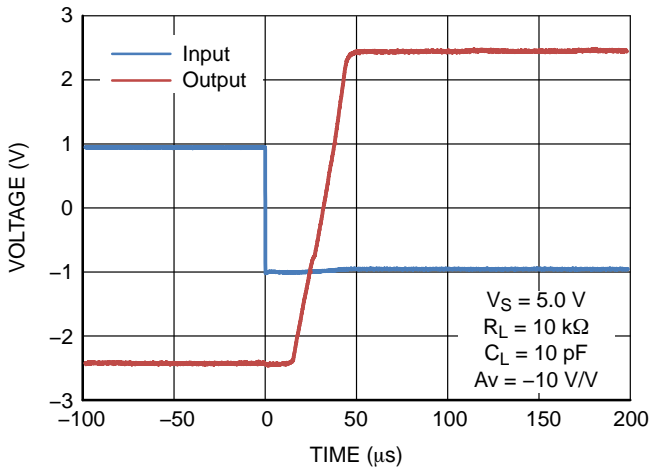

Figure 13. Negative Over Voltage Recovery

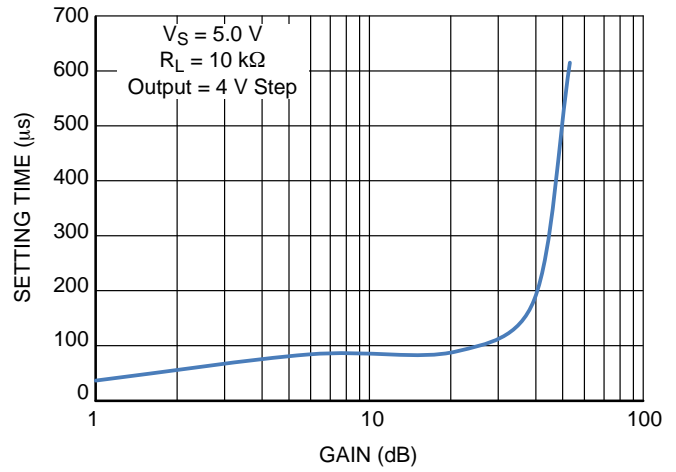

Figure 14. Setting Time vs. Closed Loop Gain

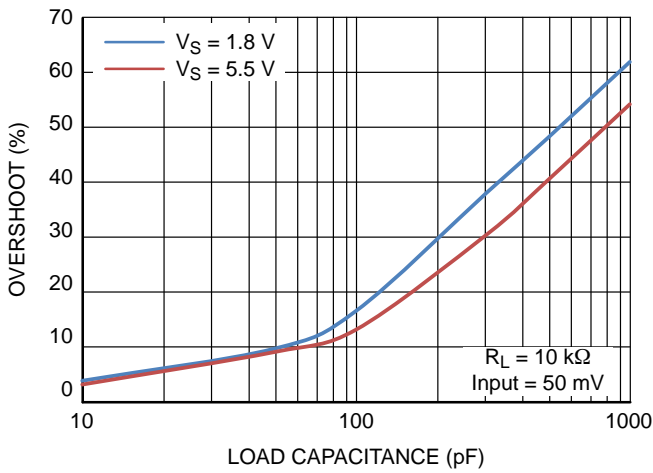

Figure 15. Small Signal Overshoot vs. Load Capacitance

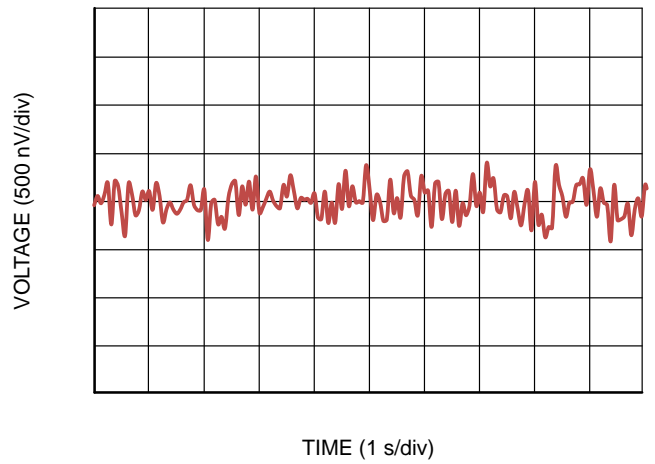

Figure 16. 0.1 Hz to 10 Hz Noise

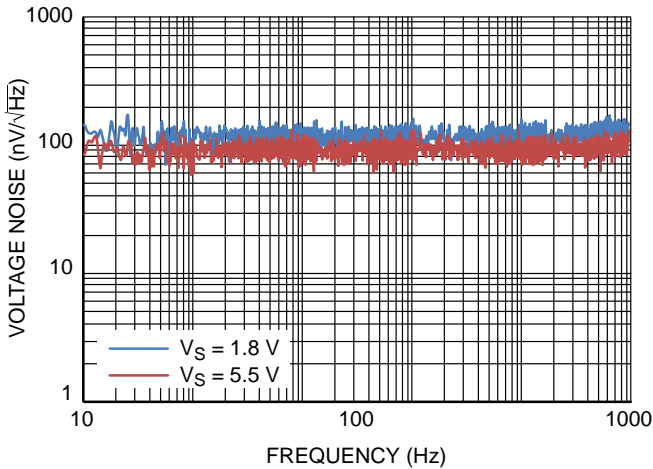

Figure 17. Voltage Noise Spectral Density vs. Frequency

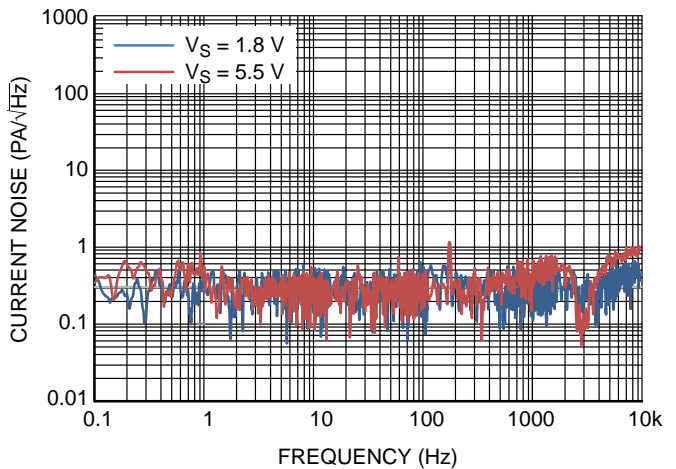

Figure 18. Current Noise Spectral Density vs. Frequency

NCS325, NCS2325, NCS4325

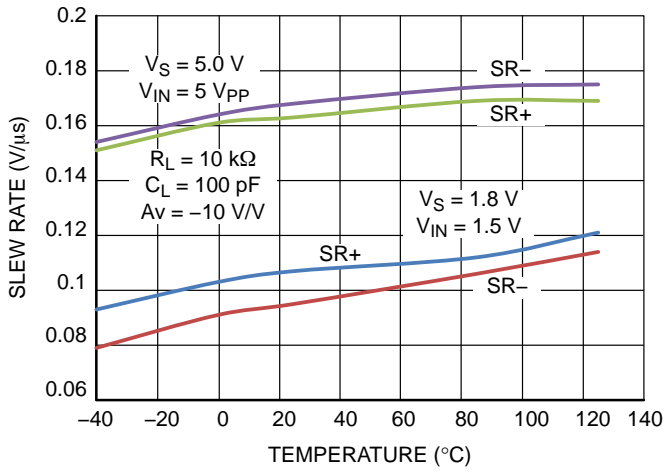

Figure 19. Slew Rate vs. Temperature

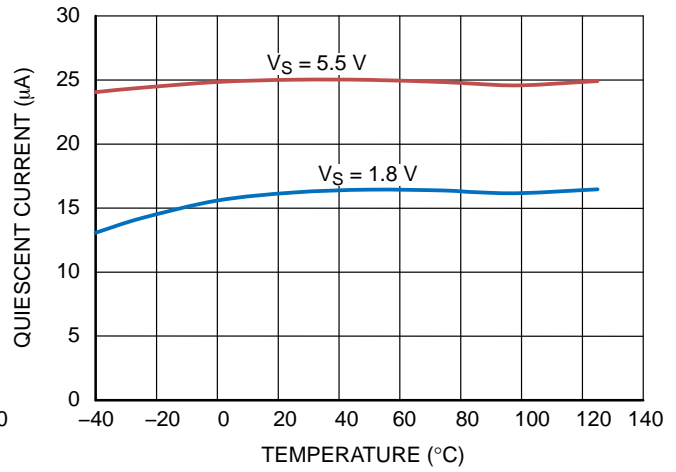

Figure 20. Quiescent Current vs. Temperature

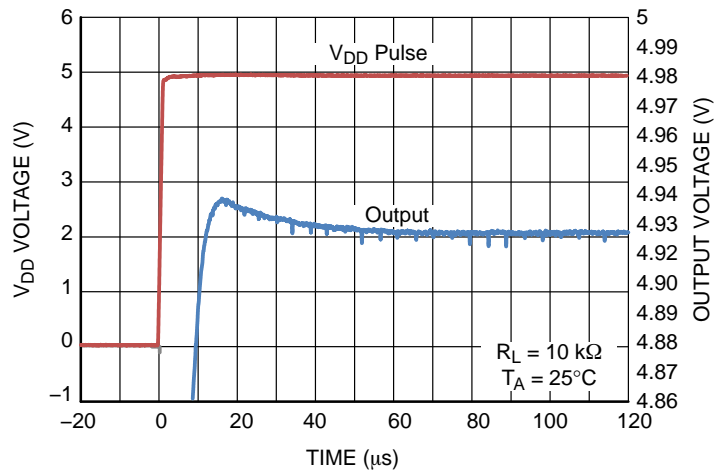

Figure 21. Turn-on Response

APPLICATIONS INFORMATION

INPUT VOLTAGE

The NCS325, NCS2325 and NCS4325 have rail-to-rail common mode input voltage range. Diodes between the inputs and the supply rails keep the input voltage from exceeding the rails.

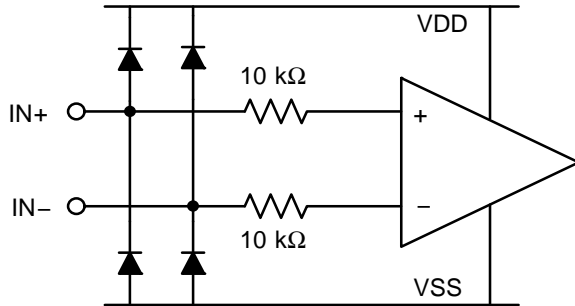

Figure 22. Equivalent Input Circuit

EMI SUSCEPTIBILITY AND INPUT FILTERING

Op amps have varying amounts of EMI susceptibility. Semiconductor junctions can pick up and rectify EMI signals, creating an EMI-induced voltage offset at the output, adding another component to the total error. Input pins are the most sensitive to EMI. The NCS325, NCS2325 and NCS4325 integrate a low-pass filter to decrease its sensitivity to EMI.

APPLICATION CIRCUITS

Low-Side Current Sensing

The goal of low-side current sensing is to detect over-current conditions or as a method of feedback control. A sense resistor is placed in series with the load to ground. Typically, the value of the sense resistor is less than 100 mΩ to reduce power loss across the resistor. The op amp amplifies the voltage drop across the sense resistor with a gain set by external resistors R1, R2, R3, and R4 (where R1 = R2, R3 = R4). Precision resistors are required for high accuracy, and the gain is set to utilize the full scale of the ADC for the highest resolution.

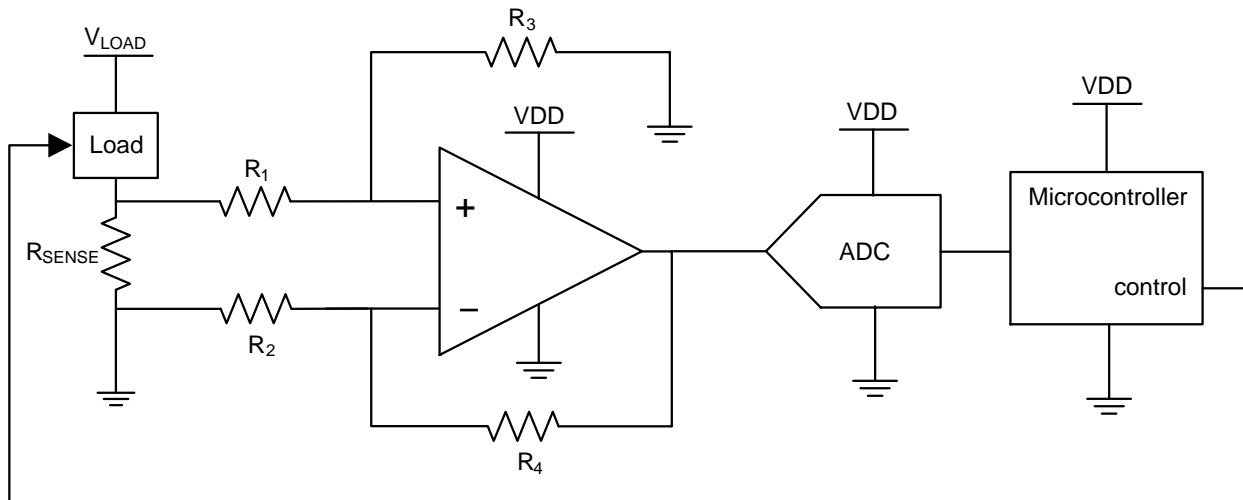

Figure 23. Low-Side Current Sensing

NCS325, NCS2325, NCS4325

Differential Amplifier for Bridged Circuits

Sensors to measure strain, pressure, and temperature are often configured in a Wheatstone bridge circuit as shown in Figure 24. In the measurement, the voltage change that is

produced is relatively small and needs to be amplified before going into an ADC. Precision amplifiers are recommended in these types of applications due to their high gain, low noise, and low offset voltage.

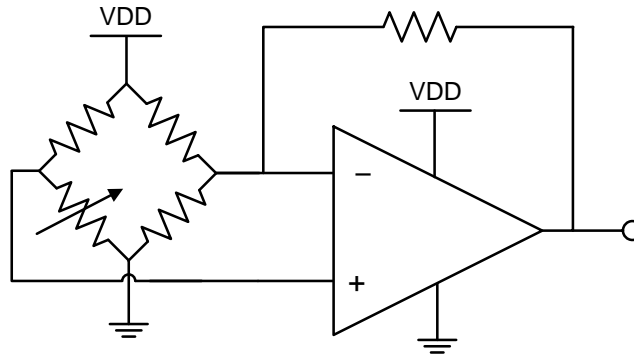

Figure 24. Bridge Circuit Amplification

GENERAL LAYOUT GUIDELINES

To ensure optimum device performance, it is important to follow good PCB design practices. Place 0.1 μ F decoupling capacitors as close as possible to the supply pins. Keep traces short, utilize a ground plane, choose surface-mount components, and place components as close as possible to

the device pins. These techniques will reduce susceptibility to electromagnetic interference (EMI). Thermoelectric effects can create an additional temperature dependent offset voltage at the input pins. To reduce these effects, use metals with low thermoelectric-coefficients and prevent temperature gradients from heat sources or cooling fans.

NCS325, NCS2325, NCS4325

PACKAGE DIMENSIONS

TSOP-5 CASE 483-02 ISSUE K

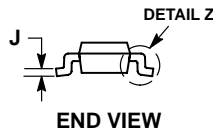
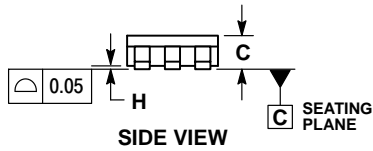
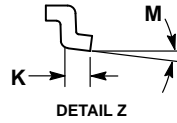
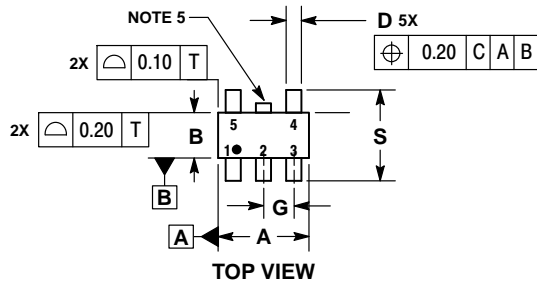

NOTES:

1. DIMENSIONING AND TOLERANCING PER ASME Y14.5M, 1994.
2. CONTROLLING DIMENSION: MILLIMETERS.
3. MAXIMUM LEAD THICKNESS INCLUDES LEAD FINISH THICKNESS. MINIMUM LEAD THICKNESS IS THE MINIMUM THICKNESS OF BASE MATERIAL.
4. DIMENSIONS A AND B DO NOT INCLUDE MOLD FLASH, PROTRUSIONS, OR GATE BURRS. MOLD FLASH, PROTRUSIONS, OR GATE BURRS SHALL NOT EXCEED 0.15 PER SIDE. DIMENSION A.
5. OPTIONAL CONSTRUCTION: AN ADDITIONAL TRIMMED LEAD IS ALLOWED IN THIS LOCATION. TRIMMED LEAD NOT TO EXTEND MORE THAN 0.2 FROM BODY.

DIM	MILLIMETERS	
	MIN	MAX
A	3.00	BSC
B	1.50	BSC
C	0.90	1.10
D	0.25	0.50
G	0.95	BSC
H	0.01	0.10
J	0.10	0.26
K	0.20	0.60
M	0°	10°
S	2.50	3.00

SOLDERING FOOTPRINT*

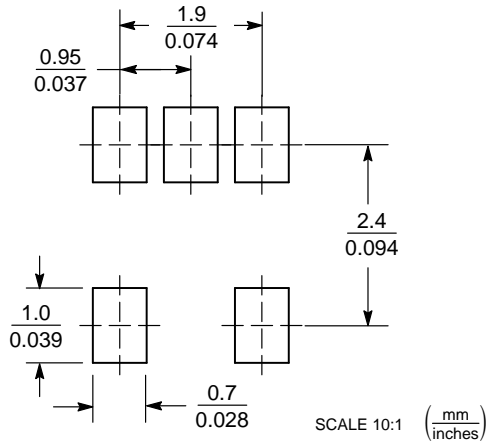

*For additional information on our Pb-Free strategy and soldering details, please download the ON Semiconductor Soldering and Mounting Techniques Reference Manual, SOLDERRM/D.

NCS325, NCS2325, NCS4325

PACKAGE DIMENSIONS

DFN8, 3x3, 0.65P
CASE 506BW-01
ISSUE O

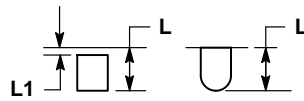
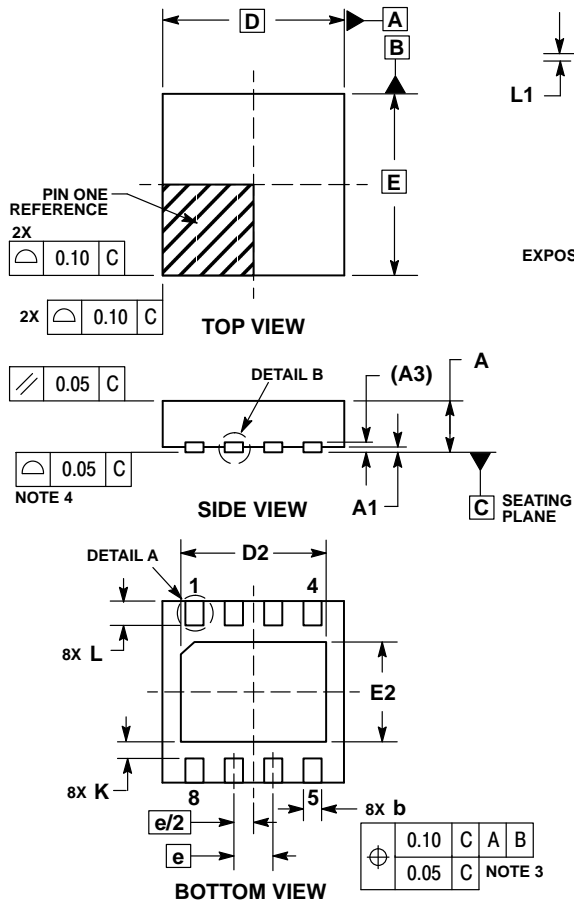

DETAIL A
OPTIONAL
CONSTRUCTIONS

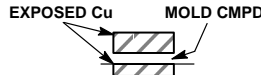

DETAIL B
OPTIONAL
CONSTRUCTIONS

NOTES:

1. DIMENSIONING AND TOLERANCING PER ASME Y14.5M, 1994.
2. CONTROLLING DIMENSION: MILLIMETERS.
3. DIMENSION b APPLIES TO PLATED TERMINAL AND IS MEASURED BETWEEN 0.15 AND 0.30mm FROM THE TERMINAL TIP.
4. COPLANARITY APPLIES TO THE EXPOSED PAD AS WELL AS THE TERMINALS.

MILLIMETERS		
DIM	MIN	MAX
A	0.80	1.00
A1	0.00	0.05
A3	0.20	REF
b	0.25	0.35
D	3.00	BSC
D2	2.30	2.50
E	3.00	BSC
E2	1.55	1.75
e	0.65	BSC
K	0.20	---
L	0.35	0.45
L1	0.00	0.15

**RECOMMENDED
SOLDERING FOOTPRINT***

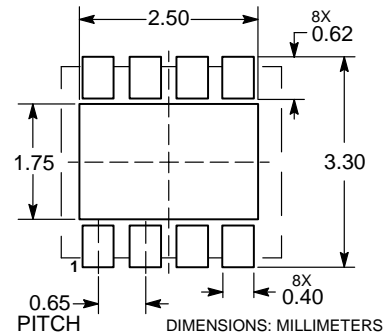

*For additional information on our Pb-Free strategy and soldering details, please download the ON Semiconductor Soldering and Mounting Techniques Reference Manual, SOLDERRM/D.

NCS325, NCS2325, NCS4325

PACKAGE DIMENSIONS

SOIC-8 NB
CASE 751-07
ISSUE AK

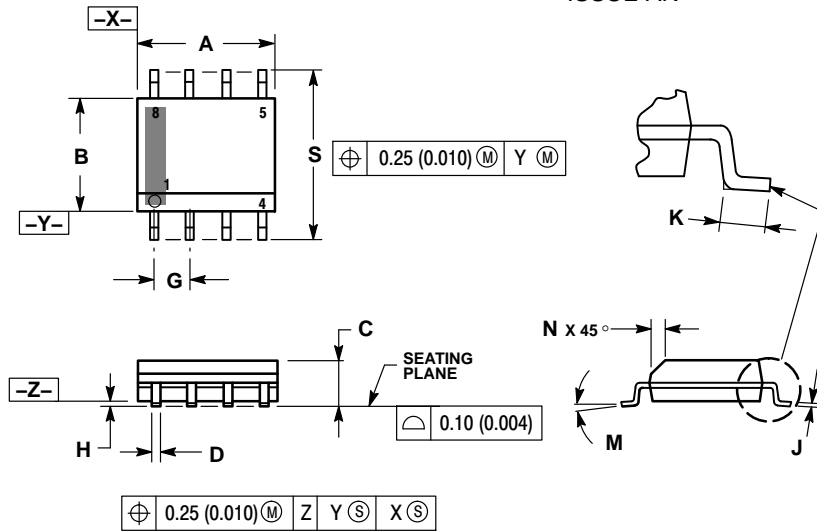

NOTES:

1. DIMENSIONING AND TOLERANCING PER ANSI Y14.5M, 1982.
2. CONTROLLING DIMENSION: MILLIMETER.
3. DIMENSION A AND B DO NOT INCLUDE MOLD PROTRUSION.
4. MAXIMUM MOLD PROTRUSION 0.15 (0.006) PER SIDE.
5. DIMENSION D DOES NOT INCLUDE DAMBAR PROTRUSION. ALLOWABLE DAMBAR PROTRUSION SHALL BE 0.127 (0.005) TOTAL IN EXCESS OF THE D DIMENSION AT MAXIMUM MATERIAL CONDITION.
6. 751-01 THRU 751-06 ARE OBSOLETE. NEW STANDARD IS 751-07.

DIM	MILLIMETERS		INCHES	
	MIN	MAX	MIN	MAX
A	4.80	5.00	0.189	0.197
B	3.80	4.00	0.150	0.157
C	1.35	1.75	0.053	0.069
D	0.33	0.51	0.013	0.020
G	1.27 BSC		0.050 BSC	
H	0.10	0.25	0.004	0.010
J	0.19	0.25	0.007	0.010
K	0.40	1.27	0.016	0.050
M	0°	8°	0°	8°
N	0.25	0.50	0.010	0.020
S	5.80	6.20	0.228	0.244

SOLDERING FOOTPRINT*

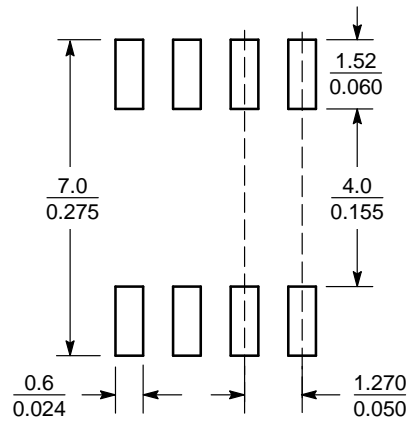

SCALE 6:1 $\left(\frac{\text{mm}}{\text{inches}}\right)$

*For additional information on our Pb-Free strategy and soldering details, please download the ON Semiconductor Soldering and Mounting Techniques Reference Manual, SOLDERRM/D.

NCS325, NCS2325, NCS4325

PACKAGE DIMENSIONS

Micro8™
CASE 846A-02
ISSUE J

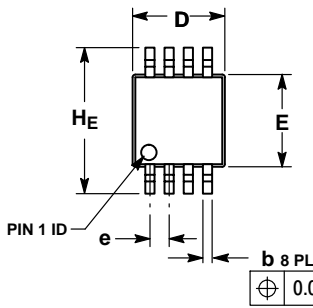

NOTES:

1. DIMENSIONING AND TOLERANCING PER ANSI Y14.5M, 1982.
2. CONTROLLING DIMENSION: MILLIMETER.
3. DIMENSION A DOES NOT INCLUDE MOLD FLASH, PROTRUSIONS OR GATE BURRS. MOLD FLASH, PROTRUSIONS OR GATE BURRS SHALL NOT EXCEED 0.15 (0.006) PER SIDE.
4. DIMENSION B DOES NOT INCLUDE INTERLEAD FLASH OR PROTRUSION. INTERLEAD FLASH OR PROTRUSION SHALL NOT EXCEED 0.25 (0.010) PER SIDE.
5. 846A-01 OBSOLETE, NEW STANDARD 846A-02.

DIM	MILLIMETERS			INCHES		
	MIN	NOM	MAX	MIN	NOM	MAX
A	—	—	1.10	—	—	0.043
A1	0.05	0.08	0.15	0.002	0.003	0.006
b	0.25	0.33	0.40	0.010	0.013	0.016
c	0.13	0.18	0.23	0.005	0.007	0.009
D	2.90	3.00	3.10	0.114	0.118	0.122
E	2.90	3.00	3.10	0.114	0.118	0.122
e	0.65 BSC			0.026 BSC		
L	0.40	0.55	0.70	0.016	0.021	0.028
HE	4.75	4.90	5.05	0.187	0.193	0.199

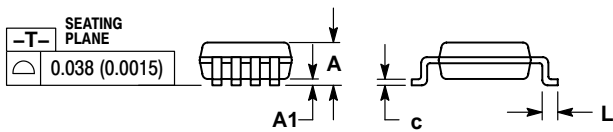

RECOMMENDED SOLDERING FOOTPRINT*

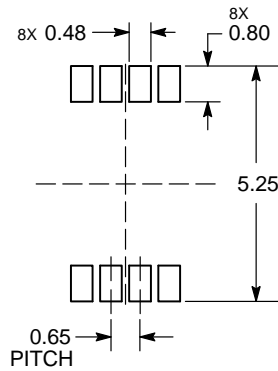

DIMENSION: MILLIMETERS

*For additional information on our Pb-Free strategy and soldering details, please download the ON Semiconductor Soldering and Mounting Techniques Reference Manual, SOLDERRM/D.

NCS325, NCS2325, NCS4325

PACKAGE DIMENSIONS

SOIC-14 NB CASE 751A-03 ISSUE L

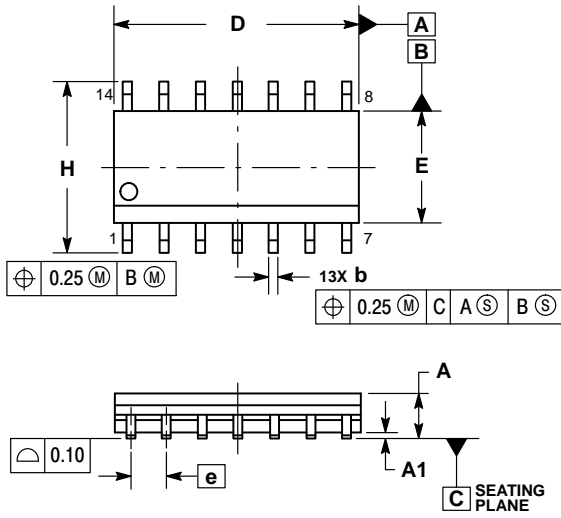

NOTES:

1. DIMENSIONING AND TOLERANCING PER ASME Y14.5M, 1994.
2. CONTROLLING DIMENSION: MILLIMETERS.
3. DIMENSION b DOES NOT INCLUDE DAMBAR PROTRUSION. ALLOWABLE PROTRUSION SHALL BE 0.13 TOTAL IN EXCESS OF AT MAXIMUM MATERIAL CONDITION.
4. DIMENSIONS D AND E DO NOT INCLUDE MOLD PROTRUSIONS.
5. MAXIMUM MOLD PROTRUSION 0.15 PER SIDE.

DIM	MILLIMETERS		INCHES	
	MIN	MAX	MIN	MAX
A	1.35	1.75	0.054	0.068
A1	0.10	0.25	0.004	0.010
A3	0.19	0.25	0.008	0.010
b	0.35	0.49	0.014	0.019
D	8.55	8.75	0.337	0.344
E	3.80	4.00	0.150	0.157
e	1.27 BSC		0.050 BSC	
H	5.80	6.20	0.228	0.244
h	0.25	0.50	0.010	0.019
L	0.40	1.25	0.016	0.049
M	0°	7°	0°	7°

SOLDERING FOOTPRINT*

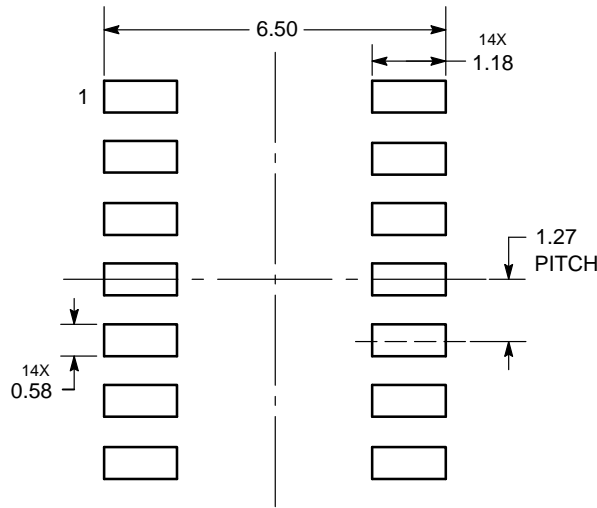

DIMENSIONS: MILLIMETERS

*For additional information on our Pb-Free strategy and soldering details, please download the ON Semiconductor Soldering and Mounting Techniques Reference Manual, SOLDERRM/D.

ON Semiconductor and are trademarks of Semiconductor Components Industries, LLC dba ON Semiconductor or its subsidiaries in the United States and/or other countries. ON Semiconductor owns the rights to a number of patents, trademarks, copyrights, trade secrets, and other intellectual property. A listing of ON Semiconductor's product/patent coverage may be accessed at www.onsemi.com/site/pdf/Patent-Marking.pdf. ON Semiconductor reserves the right to make changes without further notice to any products herein. ON Semiconductor makes no warranty, representation or guarantee regarding the suitability of its products for any particular purpose, nor does ON Semiconductor assume any liability arising out of the application or use of any product or circuit, and specifically disclaims any and all liability, including without limitation special, consequential or incidental damages. Buyer is responsible for its products and applications using ON Semiconductor products, including compliance with all laws, regulations and safety requirements or standards, regardless of any support or applications information provided by ON Semiconductor. "Typical" parameters which may be provided in ON Semiconductor data sheets and/or specifications can and do vary in different applications and actual performance may vary over time. All operating parameters, including "Typicals" must be validated for each customer application by customer's technical experts. ON Semiconductor does not convey any license under its patent rights nor the rights of others. ON Semiconductor products are not designed, intended, or authorized for use as a critical component in life support systems or any FDA Class 3 medical devices or medical devices with a same or similar classification in a foreign jurisdiction or any devices intended for implantation in the human body. Should Buyer purchase or use ON Semiconductor products for any such unintended or unauthorized application, Buyer shall indemnify and hold ON Semiconductor and its officers, employees, subsidiaries, affiliates, and distributors harmless against all claims, costs, damages, and expenses, and reasonable attorney fees arising out of, directly or indirectly, any claim of personal injury or death associated with such unintended or unauthorized use, even if such claim alleges that ON Semiconductor was negligent regarding the design or manufacture of the part. ON Semiconductor is an Equal Opportunity/Affirmative Action Employer. This literature is subject to all applicable copyright laws and is not for resale in any manner.

PUBLICATION ORDERING INFORMATION

LITERATURE FULFILLMENT:

Literature Distribution Center for ON Semiconductor
19521 E. 32nd Pkwy, Aurora, Colorado 80011 USA
Phone: 303-675-2175 or 800-344-3860 Toll Free USA/Canada
Fax: 303-675-2176 or 800-344-3867 Toll Free USA/Canada
Email: orderlit@onsemi.com

N. American Technical Support: 800-282-9855 Toll Free
USA/Canada
Europe, Middle East and Africa Technical Support:
Phone: 421 33 790 2910
Japan Customer Focus Center
Phone: 81-3-5817-1050

ON Semiconductor Website: www.onsemi.com

Order Literature: <http://www.onsemi.com/orderlit>

For additional information, please contact your local Sales Representative

Mouser Electronics

Authorized Distributor

Click to View Pricing, Inventory, Delivery & Lifecycle Information:

[onsemi:](#)

[NCS325SN2T1G](#) [NCS2325DMR2G](#) [NCS4325DR2G](#) [NCS2325DR2G](#)