

5-0SMDJ

Automotive grade 5000 W Transient voltage suppressor



Product features

- Automotive grade (AEC-Q101 qualified)
- Low profile SMC package
- Excellent clamping capability
- High reliability application
- 5000 W peak pulse power capability at 10/1000 μ s waveform
- Typical I_R less than 5 μ A
- Fast response time: typically less than 1.0 ps from 0 V to V_{BR} minimum
- High temperature reflow soldering: +260 °C /40 s at terminal
- Plastic package meets UL 94 V-0 flammability rating
- Meets moisture sensitivity level (MSL) level 1
- Terminal: Tin plated leads, solderable per J-STD-002
- For surface mounted applications in order to optimize board space

Applications

- Automotive chassis and safety systems
- Advanced driver assistance systems (ADAS)
- Communication and infotainment systems
- Network systems and body electronics
- Power Train controls
- xEV and battery systems

Environmental compliance and general specifications

- ISO16750-2 P5A: 12 V system (87 V/2 Ω /150 ms)
- ISO16750-2 P5A: 24 V system (123 V/8 Ω /150 ms)
- AEC-Q101 qualified



Ordering part number

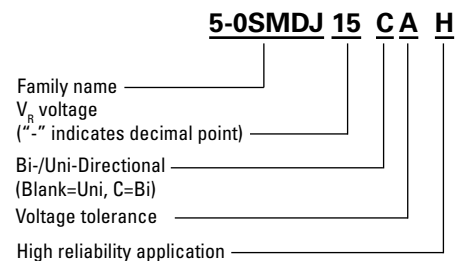

PIN configuration

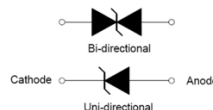
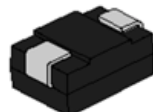

Powering Business Worldwide

Absolute maximum ratings

(+25 °C, RH=45%-75%, unless otherwise noted)

Parameter	Symbol	Value	Unit
Storage operating junction temperature range	T_{STG}/T_J	-55 to +150	°C
Steady state power dissipation at $T_L = +75$ °C	$P_{M(AV)}$	6.5	W
Peak pulse power dissipation on 10/1000 μ s waveform	P_{PP}	5000	W
Maximum instantaneous forward voltage at 100 A for unidirectional	V_F	5.0	V
Peak forward surge current, 8.3 ms single half sine wave ¹	I_{FSM}	300	A
Typical thermal resistance junction to lead	$R_{\theta JL}$	15	°C/W
Typical thermal resistance junction to ambient	$R_{\theta JA}$	75	°C/W

1. Measured on 8.3 ms single half sine wave or equivalent square wave for unidirectional device only, duty cycle = 4 per minute maximum

Mechanical parameters, pad layout- mm/inches

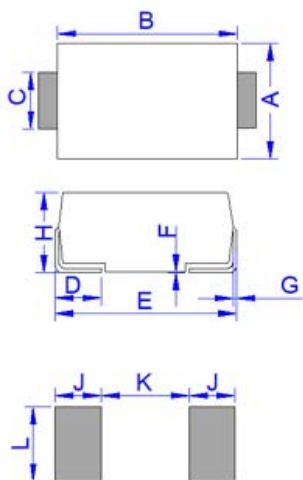

Dimension	Millimeters		Inches	
	Minimum	Maximum	Minimum	Maximum
A	5.75	6.25	0.226	0.246
B	6.90	7.40	0.272	0.291
C	2.75	3.25	0.108	0.128
D	0.95	1.52	0.037	0.060
E	7.70	8.20	0.303	0.323
F	0.051	0.203	0.002	0.008
G	0.15	0.31	0.006	0.012
H	2.15	2.62	0.085	0.103
J	2.40		0.094	
K		4.20		0.165
L	3.30		0.130	

Part marking

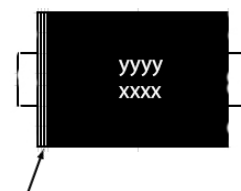

Cathode band (uni-polar only)
Part marking:
xxxx = Date code
yyyy- Refer to marking designator listed in Electrical characteristics table

Packaging information- mm/inches

Drawing not to scale.

Supplied in tape and reel packaging, 3,000 parts per 13" diameter reel (EIA-481 compliant)

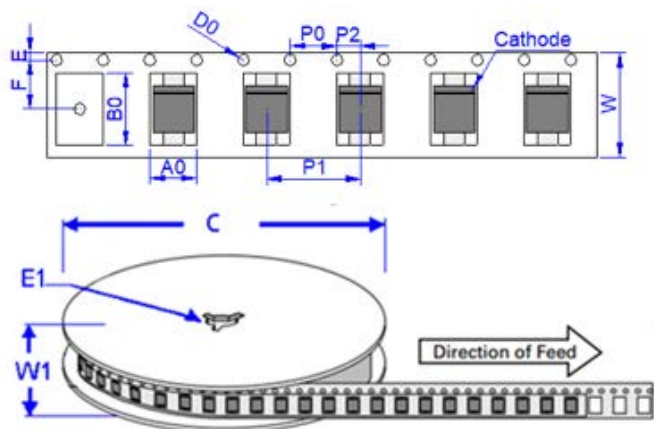

Dimensions	Millimeters	Inches
A0	6.05 ± 0.3	0.238 ± 0.012
B0	8.31 ± 0.3	0.327 ± 0.012
C	330.0	13.0
D0	1.55 ± 0.1	0.061 ± 0.004
E	1.75 ± 0.2	0.069 ± 0.008
E1	13.3 ± 0.3	0.524 ± 0.012
F	7.50 ± 0.2	0.295 ± 0.008
P0	4.00 ± 0.2	0.157 ± 0.008
P1	8.00 ± 0.2	0.3145 ± 0.008
P2	2.00 ± 0.2	0.079 ± 0.008
W	16.0 ± 0.2	0.630 ± 0.008
W1	19.7 ± 2.0	0.776 ± 0.079

Electrical characteristics (+25 °C)

Part number		Marking		V_R	$I_R @ V_R$	$V_{BR} @ I_T$		I_T	$V_C @ I_{PP}$	I_{PP}
Uni-polar	Bi-polar	Uni	Bi	(V)	(μA)	min (V)	max (V)	(mA)	max (V)	(A)
5-0SMDJ15AH	5-0SMDJ15CAH	P15A	P15C	15	5	16.7	18.5	5	24.4	205
5-0SMDJ16AH	5-0SMDJ16CAH	P16A	P16C	16	5	17.8	19.7	5	26	192
5-0SMDJ18AH	5-0SMDJ18CAH	P18A	P18C	18	5	20	22.1	5	29.2	171
5-0SMDJ20AH	5-0SMDJ20CAH	P20A	P20C	20	5	22.2	24.5	5	32.4	154
5-0SMDJ22AH	5-0SMDJ22CAH	P22A	P22C	22	5	24.4	26.9	5	35.5	141
5-0SMDJ24AH	5-0SMDJ24CAH	P24A	P24C	24	5	26.7	29.5	5	38.9	129
5-0SMDJ26AH	5-0SMDJ26CAH	P26A	P26C	26	5	28.9	31.9	5	42.1	119
5-0SMDJ28AH	5-0SMDJ28CAH	P28A	P28C	28	5	31.1	34.4	5	45.4	110
5-0SMDJ30AH	5-0SMDJ30CAH	P30A	P30C	30	5	33.3	36.8	5	48.4	103
5-0SMDJ33AH	5-0SMDJ33CAH	P33A	P33C	33	5	36.7	40.6	5	53.3	94
5-0SMDJ36AH	5-0SMDJ36CAH	P36A	P36C	36	5	40	44.2	5	58.1	86
5-0SMDJ40AH	5-0SMDJ40CAH	P40A	P40C	40	5	44.4	49.1	5	64.5	78
5-0SMDJ43AH	5-0SMDJ43CAH	P43A	P43C	43	5	47.8	52.8	5	69.4	72

Ratings and V-I characteristic curves (+25 °C unless otherwise noted)

V- I curve characteristics (Uni-directional)

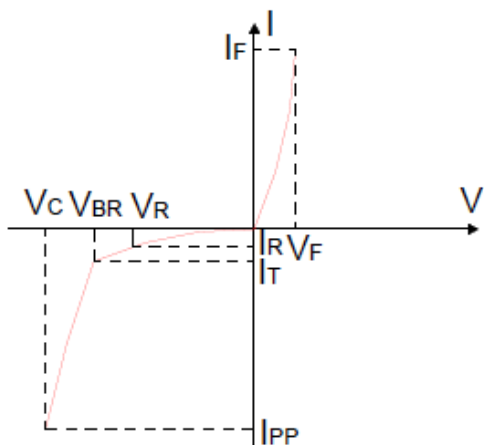

V- I curve characteristics (Bi-directional)

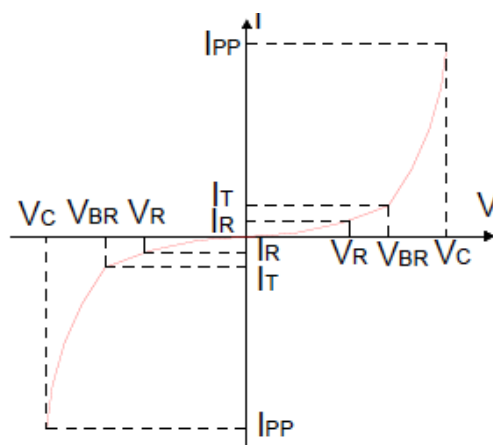

Surge waveform: 10/1000 μ s

V_R : Stand-off voltage – Maximum voltage that can be applied

V_{BR} : Breakdown voltage

V_C : Clamping voltage – Peak voltage measured across the suppressor at a specified I_{PP}

I_R : Reverse leakage current

I_T : Test current

V_F : Forward voltage drop for Uni-directional

Pulse waveform

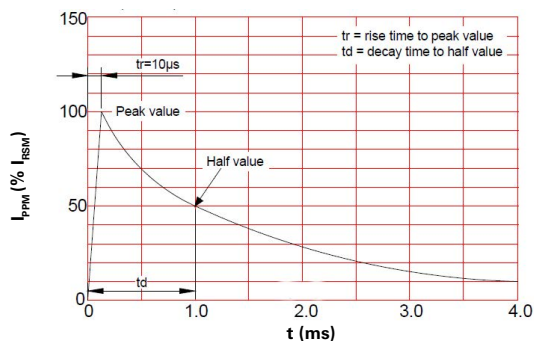

Pulse derating curve

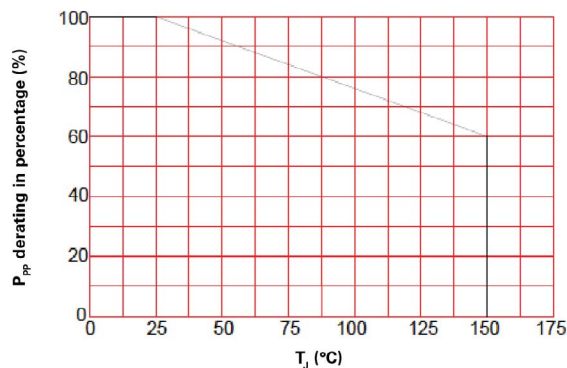

ISO16750-2 test pulse 5a

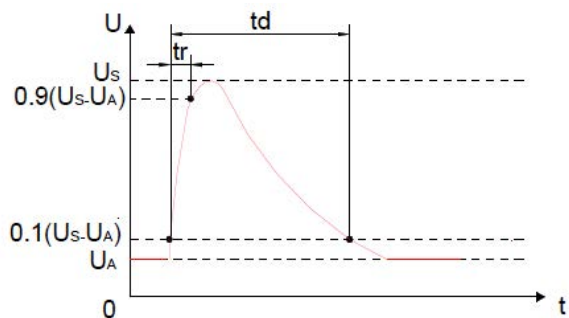

ISO16750-2 test pulse 5a conditions

Parameter	12 V system	24 V system
U_S	79 V to 101 V	151 V to 202 V
R_i	0.5 Ω to 4 Ω	1 Ω to 8 Ω
t_d	40 ms to 400 ms	100 ms to 350 ms
t_r	5 to 10 ms	5 to 10 ms

Solder reflow profile

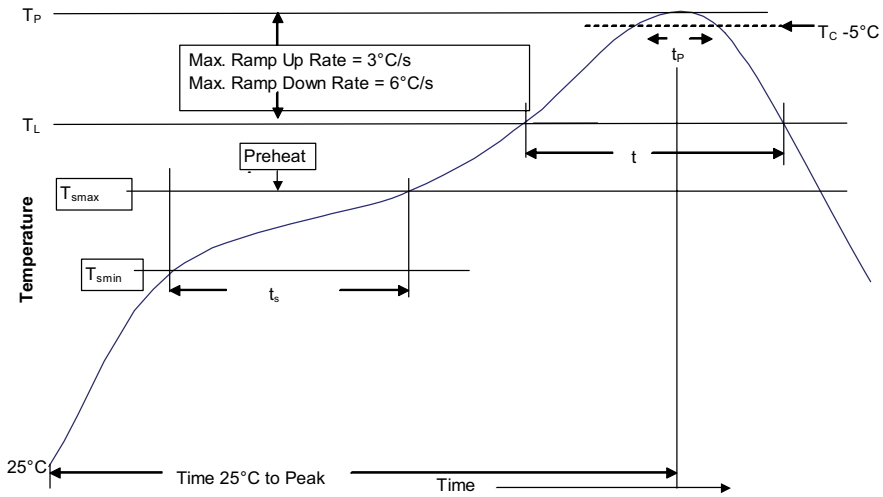

Table 1 - Standard SnPb solder (T_C)

Package thickness	Volume mm ³ <350	Volume mm ³ ≥350
<2.5 mm	235 °C	220 °C
≥2.5 mm	220 °C	220 °C

Table 2 - Lead (Pb) free solder (T_C)

Package thickness	Volume mm ³ <350	Volume mm ³ 350 - 2000	Volume mm ³ >2000
<1.6 mm	260 °C	260 °C	260 °C
1.6 – 2.5 mm	260 °C	250 °C	245 °C
>2.5 mm	250 °C	245 °C	245 °C

Reference J-STD-020

Profile feature	Standard SnPb solder	Lead (Pb) free solder
Preheat and soak	<ul style="list-style-type: none"> Temperature min. (T_{smin}) Temperature max. (T_{smax}) Time (T_{smin} to T_{smax}) (t_s) 	<ul style="list-style-type: none"> 100 °C 150 °C 60-120 seconds
Ramp up rate T _L to T _p	3 °C/ second max.	3 °C/ second max.
Liquidous temperature (T _L)	183 °C	217 °C
Time (t _L) maintained above T _L	60-150 seconds	60-150 seconds
Peak package body temperature (T _p)*	Table 1	Table 2 (+0, -5 °C)
Time (t _p)* within 5 °C of the specified classification temperature (T _C)	20 seconds*	40 seconds*
Ramp-down rate (T _p to T _L)	6 °C/ second max.	6 °C/ second max.
Time 25 °C to peak temperature	6 minutes max.	8 minutes max.

* Tolerance for peak profile temperature (T_p) is defined as a supplier minimum and a user maximum.

Life Support Policy: Eaton does not authorize the use of any of its products for use in life support devices or systems without the express written approval of an officer of the Company. Life support systems are devices which support or sustain life, and whose failure to perform, when properly used in accordance with instructions for use provided in the labeling, can be reasonably expected to result in significant injury to the user.

Eaton reserves the right, without notice, to change design or construction of any products and to discontinue or limit distribution of any products. Eaton also reserves the right to change or update, without notice, any technical information contained in this bulletin.

Eaton
Electronics Division
1000 Eaton Boulevard
Cleveland, OH 44122
United States
Eaton.com/electronics

© 2021 Eaton
All Rights Reserved
Printed in USA
Publication No. ELX1056 BU-ELX21056
July 2021

Eaton is a registered trademark.
All other trademarks are property of their respective owners.

Follow us on social media to get the latest product and support information.

