

High voltage, current sense amplifier with open drain comparator and ref



MiniSO8



SO8

Features

- Wide common mode voltage: -16 to 80 V
- 2.7 to 18 V supply voltage
- Amplification gain: 20 V/V
- 0.6 V internal reference
- Internal open-drain comparator
- Latching capability on comparator
- High accuracy: 3.5 % max. error overtemperature
- Bandwidth: 1 MHz
- Quiescent current: 1.8 mA maximum
- SO8 and MiniSO8 package

Applications

- High-side current sensing
- Low-side current sensing
- Overcurrent protection
- Telecom equipment
- Test and measurement equipment
- Industrial process control

Maturity status link

[TSC200](#)

Description

The **TSC200** is a high-side current sense amplifier which delivers an analog voltage output. It can sense current via a shunt resistor over a wide range of common mode voltages, from -16 to +80 V, whatever the supply voltage is. It is available with an amplification gain of 20 V/V.

The **TSC200** integrates an open-drain comparator with output latch function and an internal 0.6 V voltage reference connected to its input. External resistor divider can then set the switching threshold.

This device fully operates over the broad supply voltage range of 2.7 to 18 V and over the industrial temperature range of -40 to +125 °C.

1 Block diagram and pin description

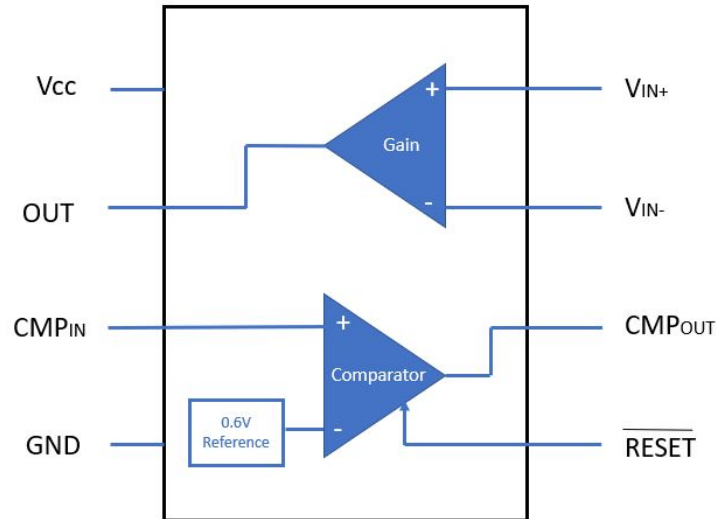
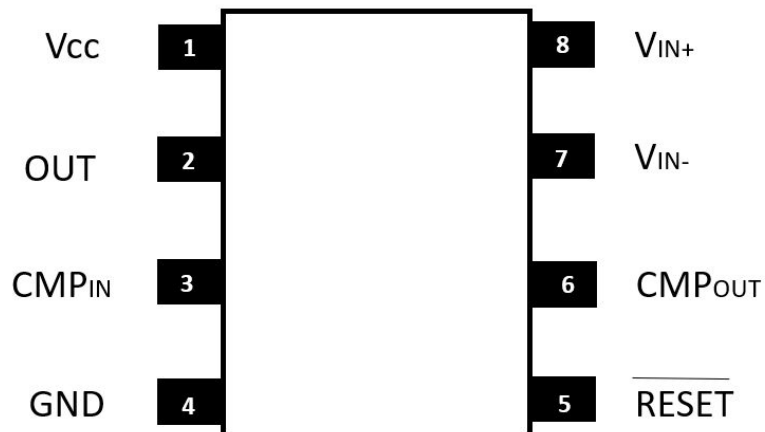
Figure 1. Block diagram

Figure 2. Pin connections (top view)

Table 1. Pin description

Pin	Pin name	Description
1	V_{CC}	Supply voltage
2	OUT	Current sense amplifier, output
3	CMP_{IN}	Comparator input
4	GND	Ground
5	RESET	Comparator reset pin, active low
6	CMP_{OUT}	Comparator output
7	V_{IN-}	Current sense amplifier, negative input
8	V_{IN+}	Current sense amplifier, positive input

2 Absolute maximum ratings and operating conditions

Table 2. Absolute maximum ratings

Symbol	Parameter	Value	Unit	
V_{CC}	Supply voltage	-0.3 to 18.3	V	
V_{IN+} , V_{IN-}	Differential voltage (V_{IN+}) – (V_{IN-})	25% V_{CC} ⁽¹⁾		
	Common mode voltage on input pins	-18 to +82		
CMP_{IN} , RESET	Voltage present on pins V_{IN+} , V_{IN-} , CMP_{IN} , RESET	Gnd -0.3 to V_{CC} +0.3	V	
OUT	Analog output	Gnd -0.3 to V_{CC} +0.3		
CMP_{OUT}	Voltage present on pin CMP_{OUT}	Gnd -0.3 to 18.3		
I_{IN}	Input current on V_{IN+} , V_{IN-}	5	mA	
T_J	Junction temperature	150	°C	
T_{STG}	Storage temperature	-65 to 150	°C	
ESD	Human Body Model (HBM)	4000	V	
	Charged Device Model (CDM)	1000		
R_{THJA}	Thermal resistance junction to ambient	SO8	125	°C/W
		MiniSO8	190	

1. For $V_{CC} \geq 12$ V, V_{diff} must not exceed 3 V.

Table 3. Operating conditions

Symbol	Parameter	Value	Unit
V_{CC}	Supply voltage	2.7 to 18	V
V_{ICM}	Common mode voltage on input pins	-16 to +80	V
T	Operating free-air temperature range	-40 to 125	°C

3 Electrical characteristics

Table 4. Electrical characteristics of the Current sense amplifier at $V_{CC} = 12\text{ V}$, $V_{ICM} = 12\text{ V}$, $V_{Sense} = 100\text{ mV}$, $R_L = 10\text{ k}\Omega$ to GND, $R_{pull-up} = 5.1\text{ k}\Omega$ connected from CMP_{OUT} to V_{CC} , $CMP_{IN} = GND$, $T = 25\text{ }^\circ\text{C}$ (unless otherwise specified)

Symbol	Parameter	Conditions	Min.	Typ.	Max.	Unit
Input						
V_{Sense}	Full scale sense input voltage			0.15	$\frac{V_{CC} - 0.25}{Gain}$	V
V_{ICM}	Common mode input range	$T_{min} < T < T_{max}$	-16		80	V
CMR	Common mode rejection	$V_{IN+} = -16$ to 80 V ,	80	110		dB
		$V_{IN+} = 12$ to 80 V , $T_{min} < T < T_{max}$	100	120		
Vos	Offset voltage, RTI ^{(1) (2)}	$T = 25\text{ }^\circ\text{C}$	-2.5	± 0.1	+2.5	mV
		$25\text{ }^\circ\text{C} < T < T_{max}$	-3		+3	
		$T_{min} < T < 25\text{ }^\circ\text{C}$	-3.5		+3.5	
$ \Delta V_{os}/\Delta T $	Offset drift (RTI) vs. temperature	$T_{min} < T < T_{max}$		0.5		$\mu\text{V}/^\circ\text{C}$
SVR	Supply voltage rejection, RTI	$V_{OUT} = 2\text{ V}$, $V_{IN+} = 18\text{ V}$, $V_{CC} = 2.7$ to 18 V , $T_{min} < T < T_{max}$		3	100	$\mu\text{V}/\text{V}$
I_{IB}	Input bias current, V_{IN-} pin	$T_{min} < T < T_{max}$		± 0.5	± 16	μA
Output ($V_{Sense} \geq 20\text{ mV}$)						
G	Gain	TSC200		20		V/V
E_G	Gain error	$V_{Sense} = 20$ to 100 mV $T_{min} < T < T_{max}$		± 0.05	± 1 ± 2	%
TE_G	Total output error ⁽³⁾	$V_{Sense} = 120\text{ mV}$, $V_{CC} = 16\text{ V}$ $T_{min} < T < T_{max}$		± 0.1	± 2.2 ± 3.5	%
NLE	Non linearity error	$V_{Sense} = 20$ to 100 mV		± 0.002		%
R_O	Output impedance			1.5		Ω
C_{Load}	Maximum capacitive load	No sustained oscillation		10		nF
Output ($V_{Sense} < 20\text{ mV}$)						
Output	TSC200	$-16 \leq V_{ICM} < 0\text{ V}$		300		mV
		$0 \leq V_{ICM} \leq V_{CC}$, $V_{CC} = 5\text{ V}$			400	
		$V_{CC} < V_{ICM} \leq 80\text{ V}$		300		
Voltage output						
V_{OH}	Output swing to the positive rail	$V_{IN-} = 11\text{ V}$, $V_{IN+} = 12\text{ V}$, $T_{min} < T < T_{max}$		$V_{CC} - 0.15$	$V_{CC} - 0.25$	mV
V_{OL}	Output swing to GND	$V_{IN-} = 0\text{ V}$, $V_{IN+} = -50\text{ mV}$, $T_{min} < T < T_{max}$		4	50	mV

Symbol	Parameter	Conditions	Min.	Typ.	Max.	Unit
Dynamic performances						
BW	$C_{Load} = 5 \text{ pF}$	TSC200		1		MHz
SR	Slew rate			7		V/ μs
Ts	Settling time	$V_{Sense} = 10 \text{ to } 100 \text{ mVpp}$ Up to 1 % final value, $C_{Load} = 5 \text{ pF}$		2		μs
Noise, RTI						
E_N	Voltage noise density	$f = 100 \text{ kHz}$		55		nV/ $\sqrt{\text{Hz}}$
Power supply						
I_{CC}	Current consumption	$V_{OUT} = 2 \text{ V}$		0.84	1.8	mA
		$V_{Sense} = 0 \text{ mV},$ $T_{min} < T < T_{max}$			1.85	
C_POR	Comparator POR threshold ⁽⁴⁾			1.5		V

1. RTI stands for "Related to input".
2. Offset is extrapolated from measurements of the output at V_{Sense} of 20 mV and 100 mV.
3. Total output error considers effects of gain error and V_{OS} inaccuracy.
4. The TSC200 is designed to power up with the comparator in a defined reset state as long as RESET is open or grounded. The comparator is in reset as long as the power supply is below the voltage shown here. The comparator assumes a state based on the comparator input above this supply voltage. If RESET is high at power-up, the comparator output comes up high and requires a reset to assume a low state, if appropriate.

Table 5. Electrical characteristics of the Comparator at $V_{CC} = 12\text{ V}$, $V_{ICM} = 12\text{ V}$, $V_{Sense} = 100\text{ mV}$, $R_L = 10\text{ k}\Omega$ to GND, $R_{pull-up} = 5.1\text{ k}\Omega$ connected from CMP_{OUT} to V_{CC} , $T = 25\text{ }^\circ\text{C}$ (unless otherwise specified)

Symbol	Parameter	Conditions	Min.	Typ.	Max.	Unit
Input						
V_{TH}	Threshold	$T = 25\text{ }^\circ\text{C}$	590	608	620	mV
		$T_{min} < T < T_{max}$	586		625	
Hyst	Hysteresis ⁽¹⁾	$T_{min} < T < T_{max}$		-9		
I_{IB}	Input bias current, CMP_{IN} pin ⁽²⁾	$T = 25\text{ }^\circ\text{C}$		0.005	10	nA
		$T_{min} < T < T_{max}$			15	
V_{IN}	Input voltage range, CMP_{IN} pin		0		$V_{CC} - 1.5$	V
Output (open-drain)						
A_v	Large signal differential voltage gain	CMP_{OUT} from 1 to 4 V $R_L \geq 15\text{ k}\Omega$ connected to 5 V		200		V/mV
I_{OH}	High level leakage current ^{(3) (4)}	$V_{ID} = 0.4\text{ V}$, $V_{OH} = V_{CC}$		0.0001	1	μA
V_{OL}	Low level output voltage ⁽³⁾	$V_{ID} = -0.6\text{ V}$, $I_{OL} = 2.35\text{ mA}$		140	300	mV
Response time						
T_P	Response time ⁽⁵⁾	R_L to 5 V, $C_{Load} = 15\text{ pF}$, 100 mV input step with 5 mV overdrive		0.3		μs
RESET						
V_T	Reset threshold ⁽⁶⁾			1.1		V
R_I	Input impedance			2		$\text{M}\Omega$
T_{DW}	Minimum $\overline{\text{Reset}}$ pulse width			0.1		μs
T_D	Propagation delay			0.1		μs

1. See Figure 3 for details, $Hysteresis = V_{TRIP-} - V_{TRIP+}$.
2. Specified by design.
3. V_{ID} is the differential voltage present at the comparator inputs.
4. Open-drain output can be pulled up to 2.7~18 V range, regardless of V_{CC} .
5. The comparator response time specified is the time interval between the input step and the instant when the output crosses 1.4 V.
6. The RESET input has an internal 2 M Ω (typical) pull-down. In case RESET pin is left open, the output shows a LOW state, with transparent comparator operation.

Figure 3. Typical comparator hysteresis

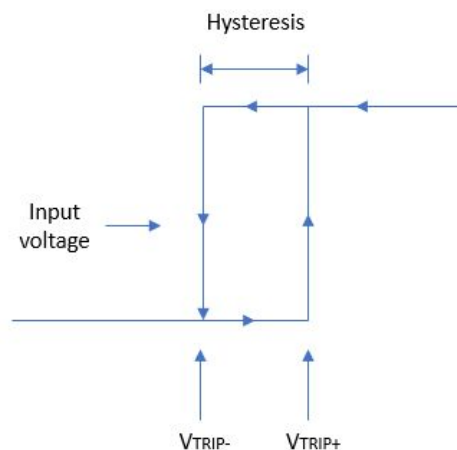

4 Typical performance characteristics

$T = 25\text{ }^{\circ}\text{C}$, $V_{CC} = 12\text{ V}$, $V_{IN+} = 12\text{ V}$ and $V_{Sense} = 100\text{ mV}$ (unless otherwise specified).

Figure 4. Gain vs. frequency ($C_L = 1000\text{ pF}$)

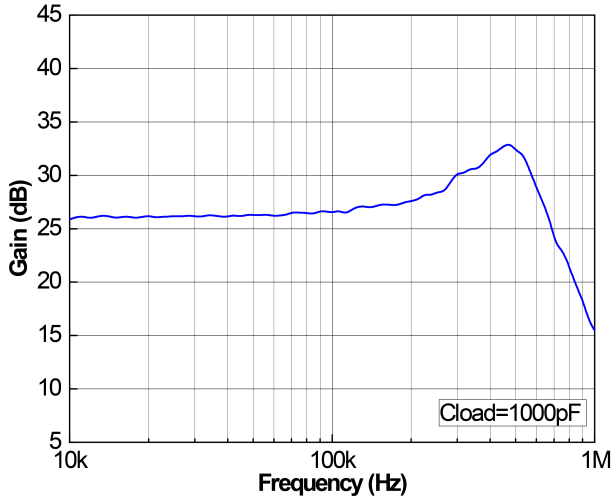

Figure 5. Gain vs. frequency ($C_L = 100\text{ pF}$)

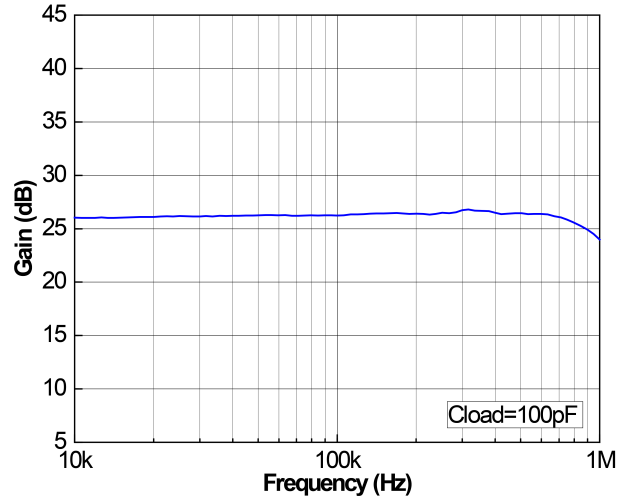

Figure 6. Gain plot

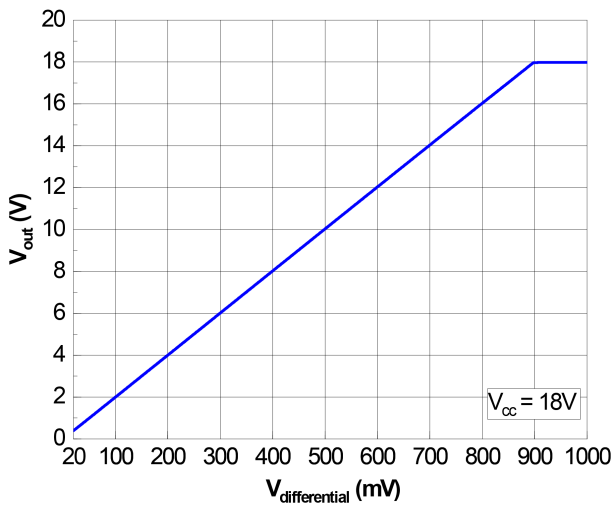

Figure 7. CMRR and PSRR vs. frequency

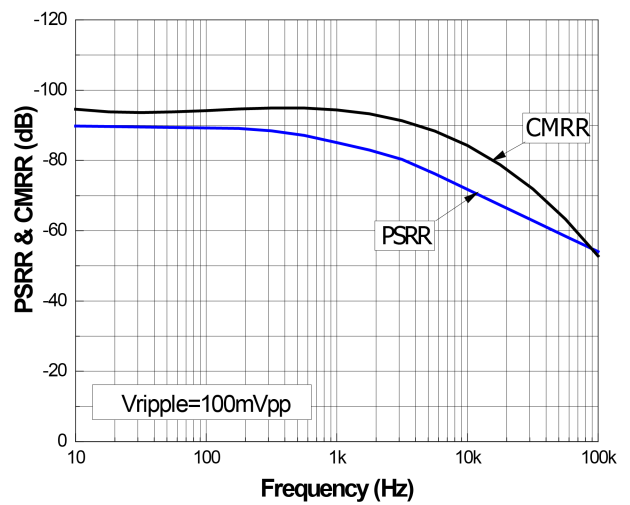

Figure 8. Output error vs. V_{sense}

Figure 9. Output error vs. common mode voltage

Figure 10. Output current vs. output voltage at $V_{CC} = 2.7V$

Figure 11. Output current vs. output voltage at $V_{CC} = 12V$

Figure 12. Quiescent current vs. output voltage

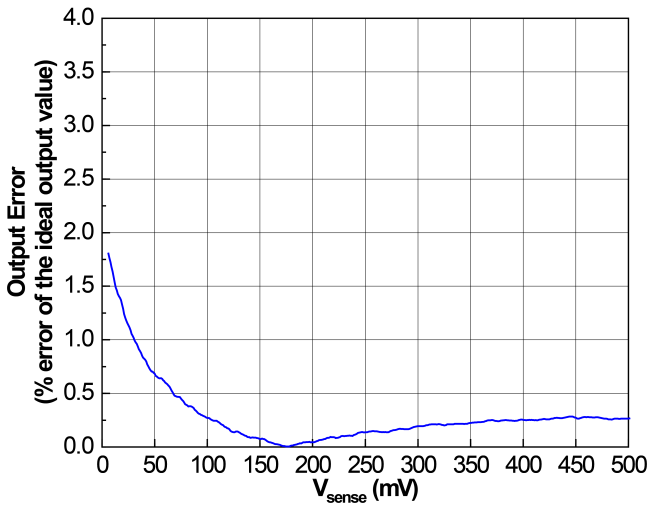
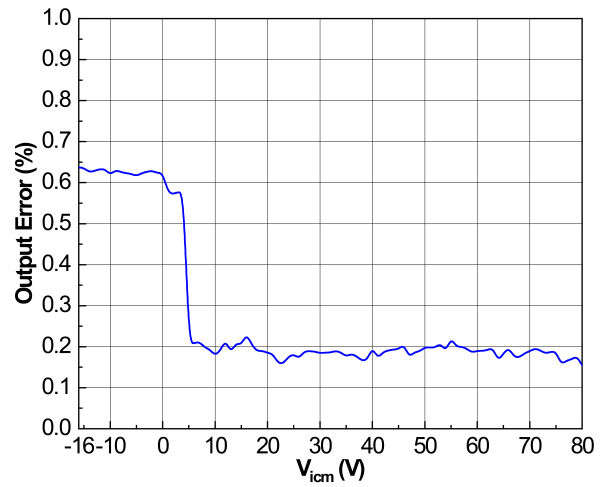
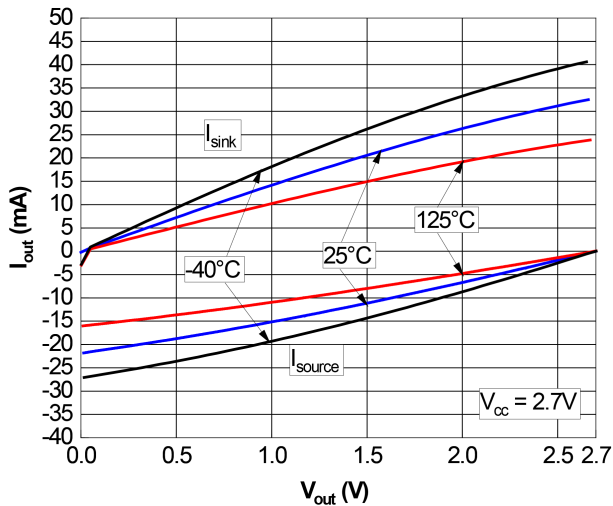
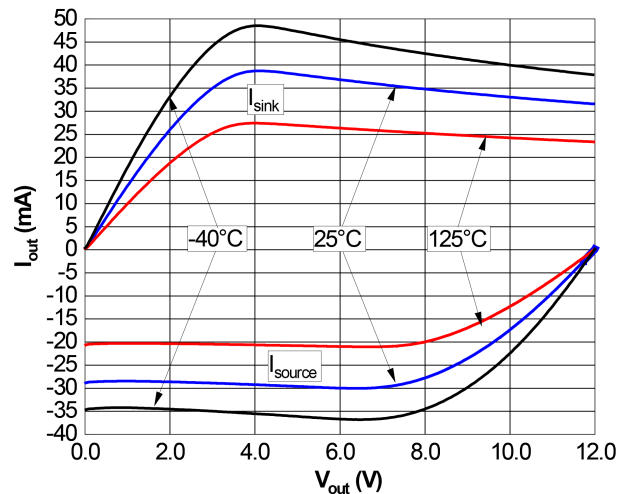
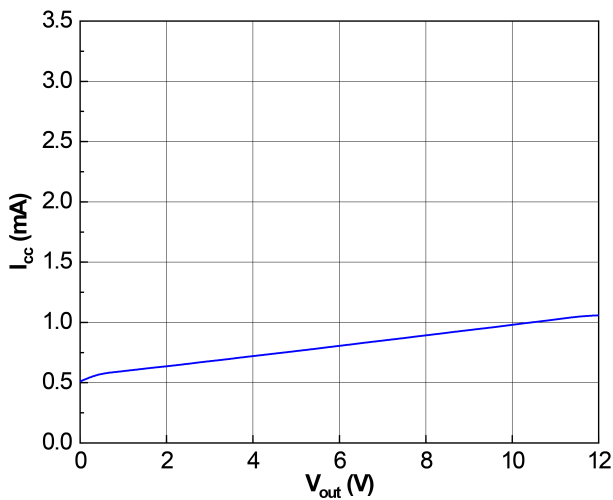
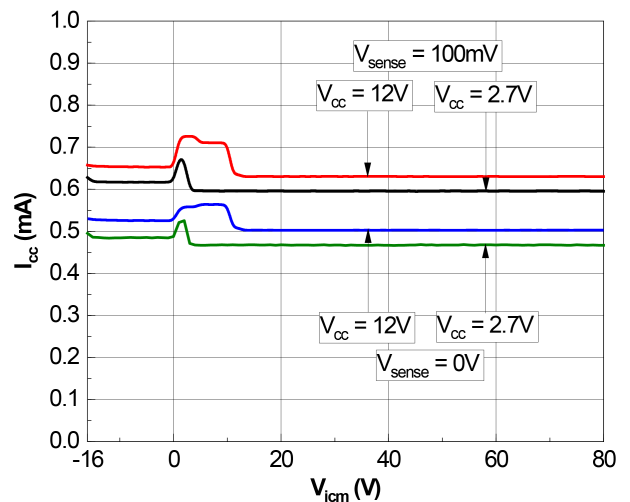
Figure 13. Quiescent current vs. common mode voltage

Figure 14. Output short-circuit current vs. supply voltage

Figure 15. Step response for 20 to 30 mV V_{sense}

Figure 16. Step response for 20 to 110 mV V_{sense}

Figure 17. Step response for 90 to 100 mV V_{sense}

Figure 18. Comparator V_{OL} vs. I_{sink}

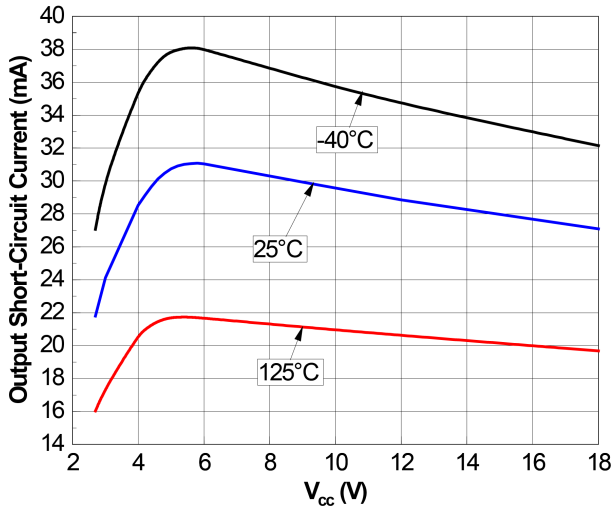
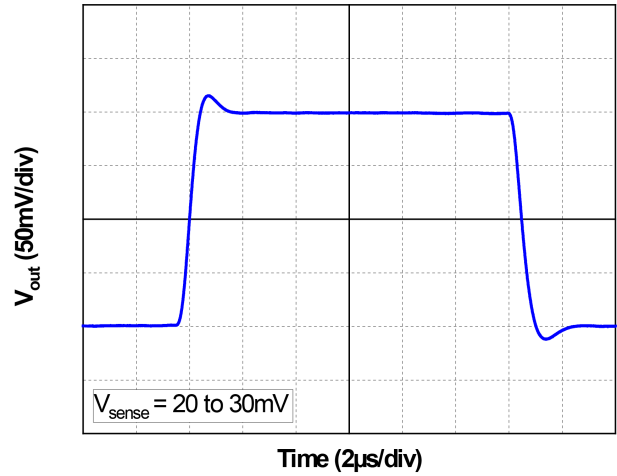
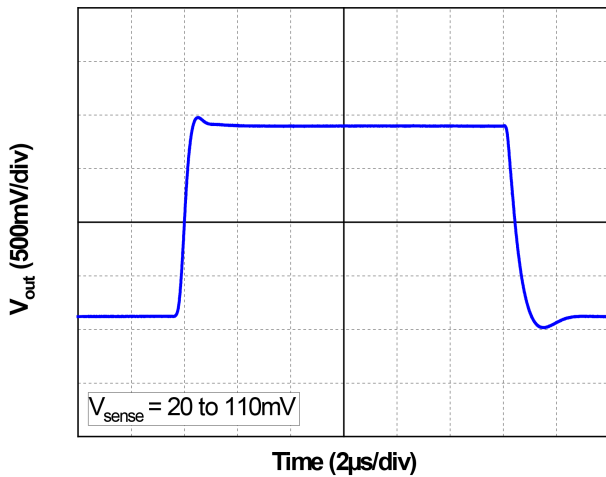
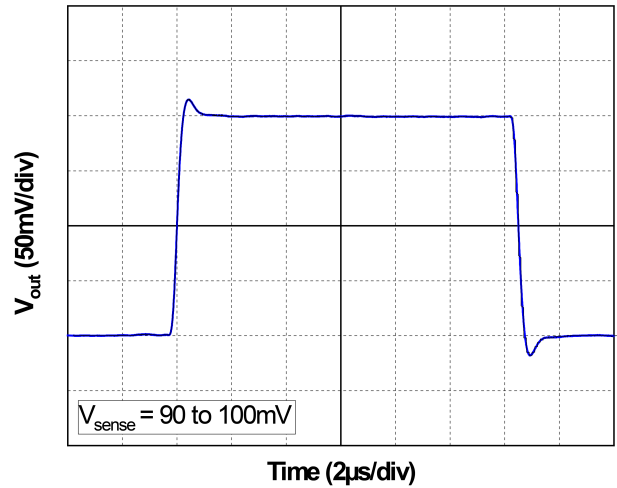
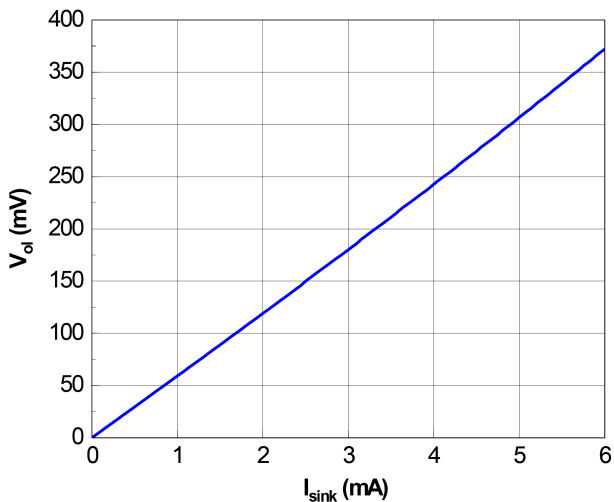
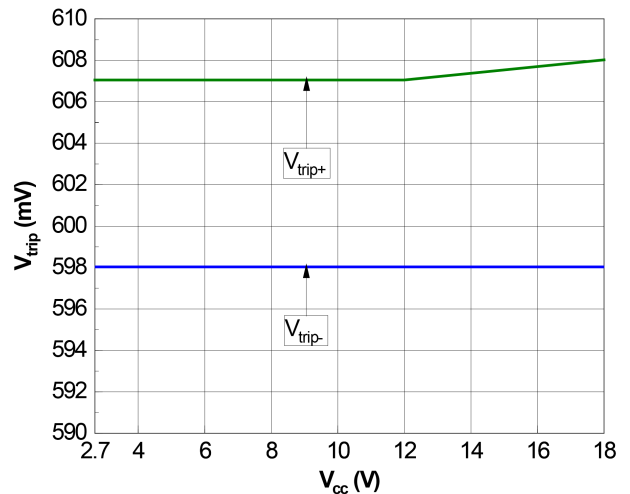
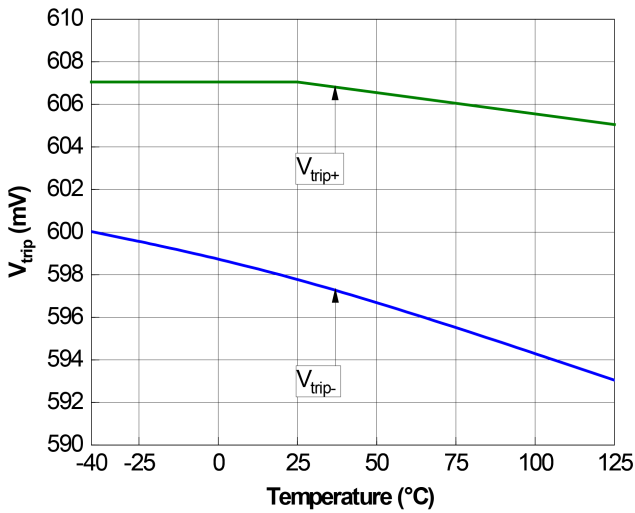
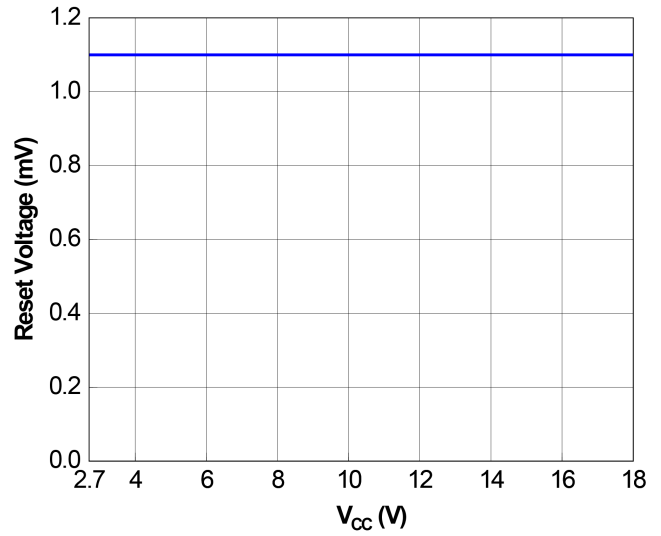
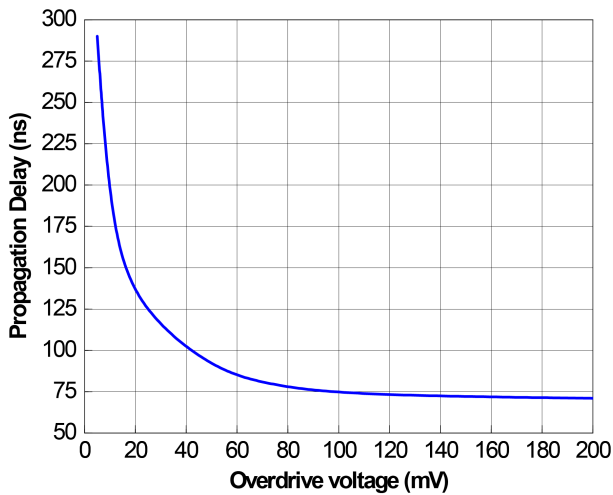
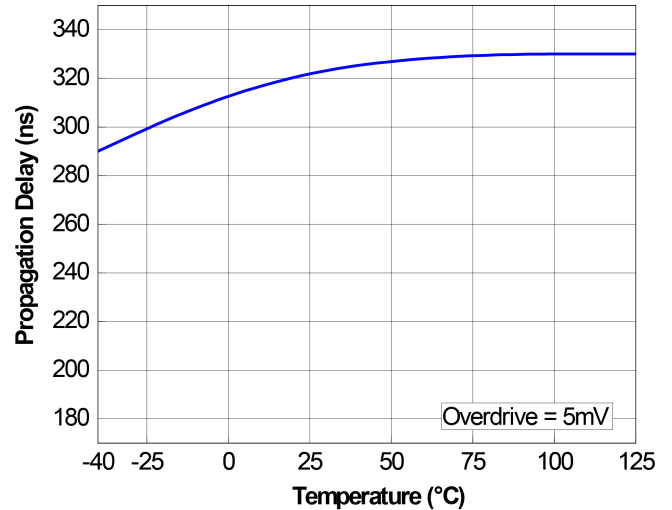
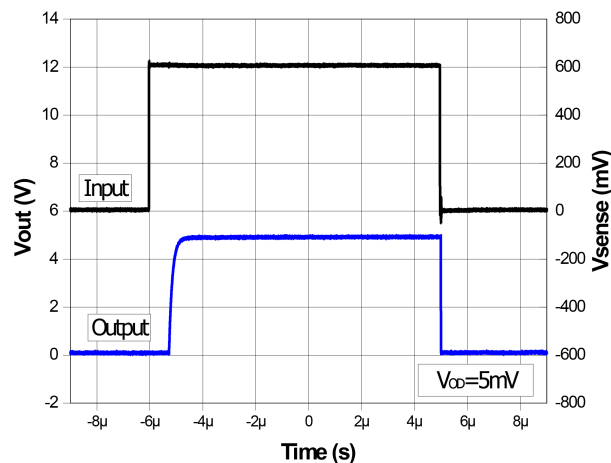
Figure 19. Comparator trip points vs. V_{CC}

Figure 20. Comparator trip points vs. temperature

Figure 21. Comparator reset voltage vs. V_{CC}

Figure 22. Comparator propagation delay vs. overdrive voltage

Figure 23. Comparator propagation delay vs. temperature

Figure 24. Comparator propagation delay

5 Package information

In order to meet environmental requirements, ST offers these devices in different grades of **ECOPACK** packages, depending on their level of environmental compliance. ECOPACK specifications, grade definitions and product status are available at: www.st.com. ECOPACK is an ST trademark.

5.1 SO8 package information

Figure 25. SO8 package outline

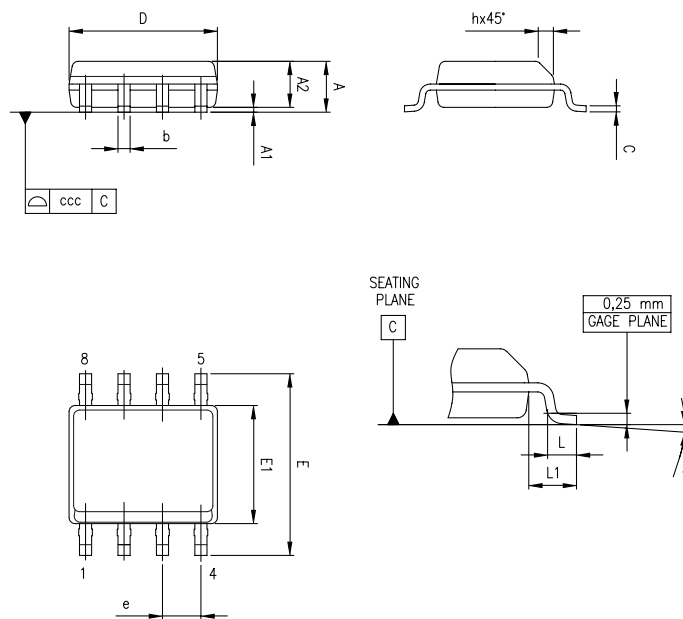

Table 6. SO8 package mechanical data

Ref.	Dimensions					
	Millimeters			Inches		
	Min.	Typ.	Max.	Min.	Typ.	Max.
A			1.75			0.069
A1	0.10		0.25	0.04		0.010
A2	1.25			0.049		
b	0.28	0.40	0.48	0.011	0.016	0.019
c	0.17		0.23	0.007		0.010
D	4.80	4.90	5.00	0.189	0.193	0.197
E	5.80	6.00	6.20	0.228	0.236	0.244
E1	3.80	3.90	4.00	0.150	0.154	0.157
e		1.27			0.050	
h	0.25		0.50	0.010		0.020
L	0.40	0.635	1.27	0.016		0.050
L1		1.04			0.040	
k	1°		8°	1°		8°
ccc			0.10			0.004

5.2 MiniSO8 package information

Figure 26. MiniSO8 package outline

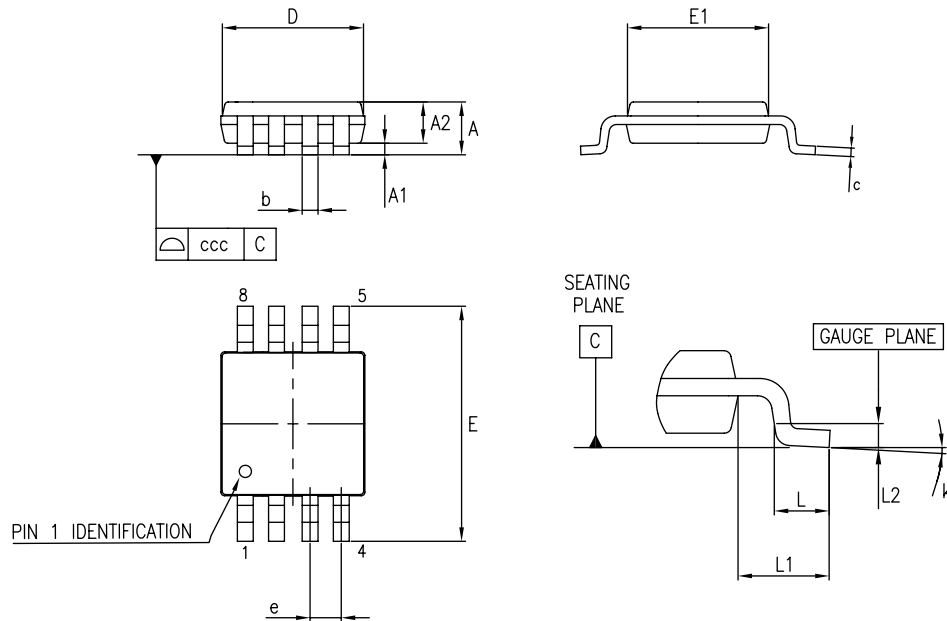

Table 7. MiniSO8 mechanical data

Dim.	Millimeters			Inches		
	Min.	Typ.	Max.	Min.	Typ.	Max.
A			1.1			0.043
A1	0		0.15	0		0.006
A2	0.75	0.85	0.95	0.03	0.033	0.037
b	0.22		0.4	0.009		0.016
c	0.08		0.23	0.003		0.009
D	2.8	3	3.2	0.11	0.118	0.126
E	4.65	4.9	5.15	0.183	0.193	0.203
E1	2.8	3	3.1	0.11	0.118	0.122
e		0.65			0.026	
L	0.4	0.6	0.8	0.016	0.024	0.031
L1		0.95			0.037	
L2		0.25			0.01	
k	0°		8°	0°		8°
ccc			0.1			0.004

6 Ordering information

Table 8. Ordering information

Order code	Gain (V/V)	Package	Packing	Marking
TSC200IDT	20	SO8	Tape and reel	TSC200I
TSC200IST	20	MiniSO8		O123

Revision history

Table 9. Document revision history

Date	Version	Changes
24-Jan-2022	1	First release.

Contents

1	Block diagram and pin description	2
2	Absolute maximum ratings and operating conditions	3
3	Electrical characteristics	4
4	Typical performance characteristics	7
5	Package information	11
5.1	SO8 package information	11
5.2	MiniSO8 package information	12
6	Ordering information	13
	Revision history	14

List of tables

Table 1.	Pin description	2
Table 2.	Absolute maximum ratings	3
Table 3.	Operating conditions	3
Table 4.	Electrical characteristics of the Current sense amplifier at $V_{CC} = 12\text{ V}$, $V_{ICM} = 12\text{ V}$, $V_{Sense} = 100\text{ mV}$, $R_L = 10\text{ k}\Omega$ to GND, $R_{pull-up} = 5.1\text{ k}\Omega$ connected from CMP_{OUT} to V_{CC} , $CMP_{IN} = GND$, $T = 25\text{ }^\circ\text{C}$ (unless otherwise specified) . .	4
Table 5.	Electrical characteristics of the Comparator at $V_{CC} = 12\text{ V}$, $V_{ICM} = 12\text{ V}$, $V_{Sense} = 100\text{ mV}$, $R_L = 10\text{ k}\Omega$ to GND, $R_{pull-up} = 5.1\text{ k}\Omega$ connected from CMP_{OUT} to V_{CC} , $T = 25\text{ }^\circ\text{C}$ (unless otherwise specified)	6
Table 6.	SO8 package mechanical data	11
Table 7.	MiniSO8 mechanical data	12
Table 8.	Ordering information.	13
Table 9.	Document revision history	14

List of figures

Figure 1.	Block diagram	2
Figure 2.	Pin connections (top view)	2
Figure 3.	Typical comparator hysteresis.	6
Figure 4.	Gain vs. frequency ($C_L = 1000 \text{ pF}$)	7
Figure 5.	Gain vs. frequency ($C_L = 100 \text{ pF}$)	7
Figure 6.	Gain plot	7
Figure 7.	CMRR and PSRR vs. frequency	7
Figure 8.	Output error vs. V_{sense}	8
Figure 9.	Output error vs. common mode voltage	8
Figure 10.	Output current vs. output voltage at $V_{\text{CC}} = 2.7 \text{ V}$	8
Figure 11.	Output current vs. output voltage at $V_{\text{CC}} = 12 \text{ V}$	8
Figure 12.	Quiescent current vs. output voltage	8
Figure 13.	Quiescent current vs. common mode voltage	8
Figure 14.	Output short-circuit current vs. supply voltage.	9
Figure 15.	Step response for 20 to 30 mV V_{sense}	9
Figure 16.	Step response for 20 to 110 mV V_{sense}	9
Figure 17.	Step response for 90 to 100 mV V_{sense}	9
Figure 18.	Comparator V_{OL} vs. I_{SINK}	9
Figure 19.	Comparator trip points vs. V_{CC}	9
Figure 20.	Comparator trip points vs. temperature	10
Figure 21.	Comparator reset voltage vs. V_{CC}	10
Figure 22.	Comparator propagation delay vs. overdrive voltage	10
Figure 23.	Comparator propagation delay vs. temperature.	10
Figure 24.	Comparator propagation delay	10
Figure 25.	SO8 package outline	11
Figure 26.	MiniSO8 package outline	12

IMPORTANT NOTICE – PLEASE READ CAREFULLY

STMicroelectronics NV and its subsidiaries (“ST”) reserve the right to make changes, corrections, enhancements, modifications, and improvements to ST products and/or to this document at any time without notice. Purchasers should obtain the latest relevant information on ST products before placing orders. ST products are sold pursuant to ST’s terms and conditions of sale in place at the time of order acknowledgement.

Purchasers are solely responsible for the choice, selection, and use of ST products and ST assumes no liability for application assistance or the design of Purchasers’ products.

No license, express or implied, to any intellectual property right is granted by ST herein.

Resale of ST products with provisions different from the information set forth herein shall void any warranty granted by ST for such product.

ST and the ST logo are trademarks of ST. For additional information about ST trademarks, please refer to www.st.com/trademarks. All other product or service names are the property of their respective owners.

Information in this document supersedes and replaces information previously supplied in any prior versions of this document.

© 2022 STMicroelectronics – All rights reserved

Mouser Electronics

Authorized Distributor

Click to View Pricing, Inventory, Delivery & Lifecycle Information:

[STMicroelectronics:](#)

[TSC200IST](#) [TSC200IDT](#)