	<b>E480232</b>
---	----------------

**Features**

- Fully Automotive Qualified to AEC-Q101
- For Surface Mount Applications
- Excellent Clamping Capability
- High Temp Soldering: 260°C / 10 Seconds at Terminals
- Halogen Free. "Green" Device (Note 1)
- Moisture Sensitivity Level 1
- Epoxy Meets UL 94 V-0 Flammability Rating
- Lead Free Finish/RoHS Compliant (Note2) ("P" Suffix Designates RoHS Compliant. See Ordering Information)
- ESD protection of data lines in accordance with IEC 61000-4-2, ±30kV(Air), ±30kV (Contact)



**Maximum Ratings**

Parameter	Symbol	Value	Unit
Peak Pulse Power Surge Current with a 10/1000µs Waveform (Note 3)	$I_{PPM}$	See Next Table	A
Peak Pulse Power Dissipation (Note 3)	$P_{PPM}$	400	W
Power Dissipation on Infinite Heatsink at $T_a = 25^\circ\text{C}$	$P_D$	1.25	W
Peak Forward Surge Current Unidirectional Only (Note 4)	$I_{FSM}$	40	A

**Note:**

1. Halogen free "Green" products are defined as those which contain <900ppm bromine, <900ppm chlorine (<1500ppm total Br + Cl) and <1000ppm antimony compounds.
2. High Temperature Solder Exemption Applied, see EU Directive Annex 7a.
3. Non-repetitive current pulse, per Fig.3 and derated above  $T_a = 25^\circ\text{C}$  per Fig.4.
4. 8.3ms, single half sine wave duty cycle = 4 pulses per Minutes maximum.

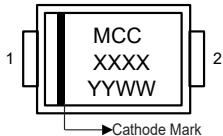
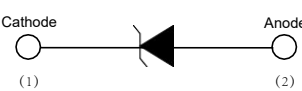
**Internal Structure**

Description	Simplified outline	Graphic symbol
Uni-directional		
Bi-directional		

XXXX = Marking code YYWW = Date Code

**400 Watt TVS  
5.0 to 190  
Volts**

**SMA (DO-214AC)  
LEAD FRAME**

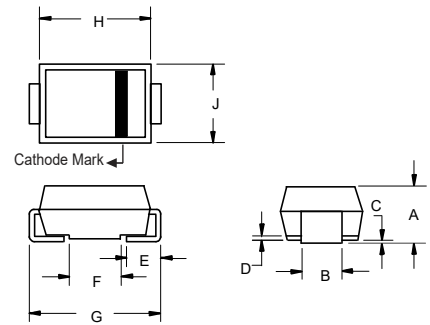

DIM	INCHES		MM		NOTE
	MIN	MAX	MIN	MAX	
A	0.075	0.096	1.90	2.44	
B	0.050	0.064	1.27	1.63	
C	0.002	0.008	0.051	0.203	
D	---	0.020	---	0.51	
E	0.030	0.060	0.76	1.52	
F	0.065	0.091	1.65	2.32	
G	0.189	0.220	4.80	5.59	
H	0.157	0.187	4.00	4.75	
J	0.090	0.115	2.25	2.92	

**SUGGESTED SOLDER PAD LAYOUT**

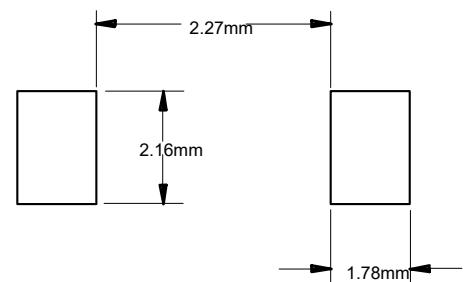

## Thermal Characteristics

Parameter	Symbol	Value	Unit
Operating Junction Temperature Range	$T_J$	-55 to +175	°C
Storage Temperature Range	$T_{STG}$	-55 to +175	°C
Typical Thermal Resistance Junction to Lead	$R_{\theta JL}$	30	°C/W
Typical Thermal Resistance Junction to Ambient	$R_{\theta JA}$	120	°C/W
Typical Thermal Resistance Junction to Case	$R_{\theta JC}$	50	°C/W

**Note:**

5. Mounted on 0.2 x 0.2" (5.0 x 5.0 mm) copper pads to each terminal.

Electrical Characteristics @ 25°C Unless Otherwise Specified

MCC Part Number		Working Peak Reverse Voltage	Breakdown Voltage $V_{BR}@I_T$			Maximum Clamping Voltage @ $I_{PP}$	Maximum Reverse Surge Current	Maximum Reverse Leakage @ $V_{RWM}$	Device Marking Code	
(Uni)	(Bi)	$V_{RWM}(V)$	Min (V)	Max (V)	$I_T$ (mA)	$V_C(V)$	$I_{PP}(A)$	$I_R(\mu A)$	Uni	Bi
SMAJ5.0AQ	SMAJ5.0CAQ	5.0	6.40	7.07	10	9.2	43.4	800	AE	WE
SMAJ6.0AQ	SMAJ6.0CAQ	6.0	6.67	7.37	10	10.3	38.8	800	AG	WG
SMAJ6.5AQ	SMAJ6.5CAQ	6.5	7.22	7.98	10	11.2	35.7	500	AK	WK
SMAJ7.0AQ	SMAJ7.0CAQ	7.0	7.78	8.60	10	12.0	33.3	200	AM	WM
SMAJ7.5AQ	SMAJ7.5CAQ	7.5	8.33	9.21	1	12.9	31.0	100	AP	WP
SMAJ8.0AQ	SMAJ8.0CAQ	8.0	8.89	9.83	1	13.6	29.4	50	AR	WR
SMAJ8.5AQ	SMAJ8.5CAQ	8.5	9.44	10.40	1	14.4	27.8	10	AT	WT
SMAJ9.0AQ	SMAJ9.0CAQ	9.0	10.00	11.10	1	15.4	26.0	5	AV	WV
SMAJ10AQ	SMAJ10CAQ	10.0	11.10	12.30	1	17.0	23.5	5	AX	WX
SMAJ11AQ	SMAJ11CAQ	11.0	12.20	13.50	1	18.2	22.0	1	AZ	WZ
SMAJ12AQ	SMAJ12CAQ	12.0	13.30	14.70	1	19.9	20.1	1	BE	XE
SMAJ13AQ	SMAJ13CAQ	13.0	14.40	15.90	1	21.5	18.6	1	BG	XG
SMAJ14AQ	SMAJ14CAQ	14.0	15.60	17.20	1	23.2	17.2	1	BK	XK
SMAJ15AQ	SMAJ15CAQ	15.0	16.70	18.50	1	24.4	16.4	1	BM	XM
SMAJ16AQ	SMAJ16CAQ	16.0	17.80	19.70	1	26.0	15.4	1	BP	XP
SMAJ17AQ	SMAJ17CAQ	17.0	18.90	20.90	1	27.6	14.5	1	BR	XR
SMAJ18AQ	SMAJ18CAQ	18.0	20.00	22.10	1	29.2	13.7	1	BT	XT
SMAJ19AQ	SMAJ19CAQ	19.0	21.10	23.30	1	30.8	13.0	1	BU	XU
SMAJ20AQ	SMAJ20CAQ	20.0	22.20	24.50	1	32.4	12.4	1	BV	XV
SMAJ22AQ	SMAJ22CAQ	22.0	24.40	26.90	1	35.5	11.3	1	BX	XX
SMAJ24AQ	SMAJ24CAQ	24.0	26.70	29.50	1	38.9	10.3	1	BZ	XZ
SMAJ26AQ	SMAJ26CAQ	26.0	28.90	31.90	1	42.1	9.5	1	CE	YE
SMAJ28AQ	SMAJ28CAQ	28.0	31.10	34.40	1	45.4	8.8	1	CG	YG
SMAJ30AQ	SMAJ30CAQ	30.0	33.30	36.80	1	48.4	8.3	1	CK	YK
SMAJ33AQ	SMAJ33CAQ	33.0	36.70	40.60	1	53.3	7.5	1	CM	YM
SMAJ36AQ	SMAJ36CAQ	36.0	40.00	44.20	1	58.1	6.9	1	CP	YP
SMAJ40AQ	SMAJ40CAQ	40.0	44.40	49.10	1	64.5	6.2	1	CR	YR
SMAJ43AQ	SMAJ43CAQ	43.0	47.80	52.80	1	69.4	5.8	1	CT	YT
SMAJ45AQ	SMAJ45CAQ	45.0	50.00	55.30	1	72.7	5.5	1	CV	YV
SMAJ48AQ	SMAJ48CAQ	48.0	53.30	58.90	1	77.4	5.2	1	CX	YX
SMAJ51AQ	SMAJ51CAQ	51.0	56.70	62.70	1	82.4	4.9	1	CZ	YZ
SMAJ54AQ	SMAJ54CAQ	54.0	60.00	66.30	1	87.1	4.6	1	RE	ZE
SMAJ58AQ	SMAJ58CAQ	58.0	64.40	71.20	1	93.6	4.3	1	RG	ZG
SMAJ60AQ	SMAJ60CAQ	60.0	66.70	73.70	1	96.8	4.1	1	RK	ZK
SMAJ64AQ	SMAJ64CAQ	64.0	71.10	78.60	1	103.0	3.9	1	RM	ZM
SMAJ70AQ	SMAJ70CAQ	70.0	77.80	86.00	1	113.0	3.5	1	RP	ZP
SMAJ75AQ	SMAJ75CAQ	75.0	83.30	92.10	1	121.0	3.3	1	RR	ZR
SMAJ78AQ	SMAJ78CAQ	78.0	86.70	95.80	1	126.0	3.2	1	RT	ZT
SMAJ80AQ	SMAJ80CAQ	80.0	88.80	97.60	1	129.0	3.1	1	RB	ZB
SMAJ85AQ	SMAJ85CAQ	85.0	94.40	104.00	1	137.0	2.9	1	RV	ZV
SMAJ90AQ	SMAJ90CAQ	90.0	100.00	111.00	1	146.0	2.7	1	RX	ZX
SMAJ100AQ	SMAJ100CAQ	100.0	111.00	123.00	1	162.0	2.5	1	RZ	ZZ
SMAJ110AQ	SMAJ110CAQ	110.0	122.00	135.00	1	177.0	2.3	1	SE	VE
SMAJ120AQ	SMAJ120CAQ	120.0	133.00	147.00	1	193.0	2.1	1	SG	VG
SMAJ130AQ	SMAJ130CAQ	130.0	144.00	159.00	1	209.0	1.9	1	SK	VK
SMAJ140AQ	SMAJ140CAQ	140.0	155.00	171.00	1	226.8	1.8	1	SL	VL
SMAJ150AQ	SMAJ150CAQ	150.0	167.00	185.00	1	243.0	1.7	1	SM	VM
SMAJ160AQ	SMAJ160CAQ	160.0	178.00	197.00	1	259.0	1.5	1	SP	VP
SMAJ170AQ	SMAJ170CAQ	170.0	189.00	209.00	1	275.0	1.5	1	SR	VR
SMAJ180AQ	SMAJ180CAQ	180.0	200.00	220.00	1	291.6	1.4	1	ST	VT
SMAJ190AQ	SMAJ190CAQ	190.0	211.00	232.00	1	307.8	1.3	1	SU	VU

**Curve Characteristics**

Fig. 1 - Peak Pulse Power Rating Curve

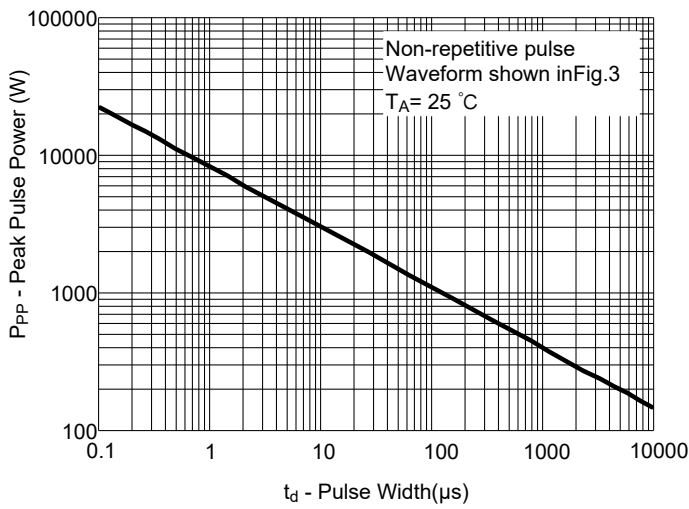

Fig. 2 - Typical Junction Capacitance

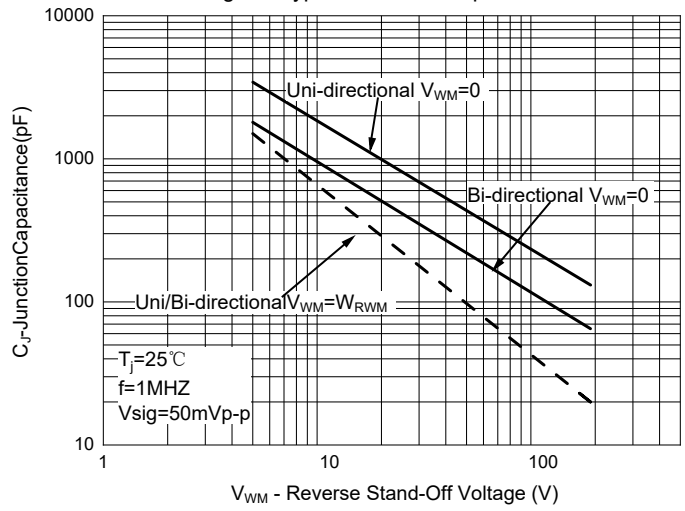

Fig. 3 - Pulse Waveform

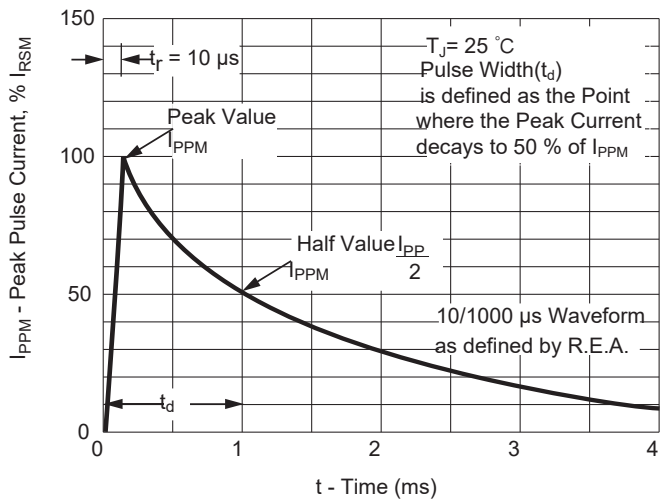
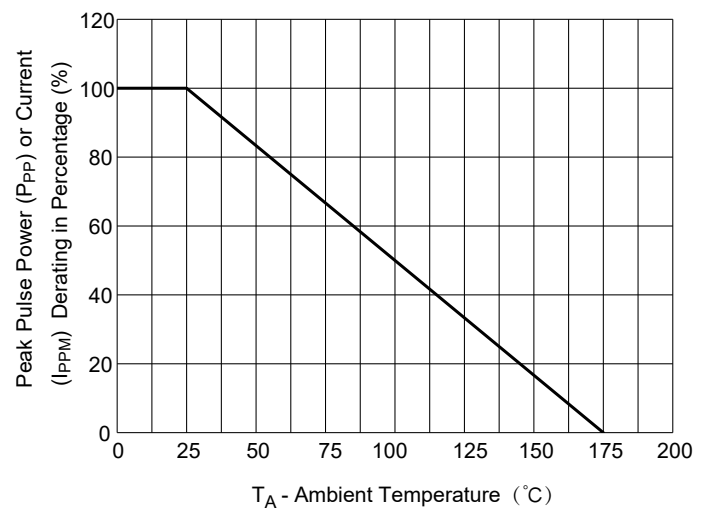

Fig. 4 - Pulse Derating Curve



## Ordering Information

Device	Packing
Part Number-TP	Tape&Reel:5Kpcs/Reel

**\*\*\*IMPORTANT NOTICE\*\*\***

*Micro Commercial Components Corp.* reserves the right to make changes without further notice to any product herein to make corrections, modifications, enhancements, improvements, or other changes. *Micro Commercial Components Corp.* does not assume any liability arising out of the application or use of any product described herein; neither does it convey any license under its patent rights, nor the rights of others. The user of products in such applications shall assume all risks of such use and will agree to hold *Micro Commercial Components Corp.* and all the companies whose products are represented on our website, harmless against all damages. *Micro Commercial Components Corp.* products are sold subject to the general terms and conditions of commercial sale, as published at <https://www.mccsemi.com/Home/TermsAndConditions>.

**\*\*\*LIFE SUPPORT\*\*\***

MCC's products are not authorized for use as critical components in life support devices or systems without the express written approval of Micro Commercial Components Corporation.

**\*\*\*CUSTOMER AWARENESS\*\*\***

Counterfeiting of semiconductor parts is a growing problem in the industry. Micro Commercial Components (MCC) is taking strong measures to protect ourselves and our customers from the proliferation of counterfeit parts. MCC strongly encourages customers to purchase MCC parts either directly from MCC or from Authorized MCC Distributors who are listed by country on our web page cited below. Products customers buy either from MCC directly or from Authorized MCC Distributors are genuine parts, have full traceability, meet MCC's quality standards for handling and storage. **MCC will not provide any warranty coverage or other assistance for parts bought from Unauthorized Sources.** MCC is committed to combat this global problem and encourage our customers to do their part in stopping this practice by buying direct or from authorized distributors.