

Arm® Cortex®-M33 32-bit MCU with FPU, at 144 MHz, 593 CoreMark®, 1 Mbyte flash memory, 256-Kbyte RAM, I3C, cryptography

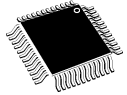

LQFP32 (7 x 7 mm)
LQFP48 (7 x 7 mm)
LQFP64 (10 x 10 mm)
LQFP80 (12 x 12 mm)
LQFP100 (14 x 14 mm)
LQFP144 (14 x 14 mm)



UFQFPN32 (5 x 5 mm)
UFQFPN48 (7 x 7 mm)

Features

Includes ST state-of-the-art patented technology.

Core

- 32-bit Arm® Cortex®-M33 CPU with FPU, frequency up to 144 MHz, MPU, and DSP instructions

Benchmarks

- 593 CoreMark® (4.12 CoreMark®/MHz)

ART Accelerator

- 8-Kbyte instruction cache allowing 0-wait-state execution from flash and up to CPU maximum speed

Memories

- 1-Mbyte flash memory with ECC, 2 banks read-while-write
- 256-Kbyte SRAM including 128-Kbyte with ECC
- 64-Kbyte user data flash memory, 2 banks
- 4.5-Kbyte OTP (one-time programmable)
- One Octo-SPI memory interface and support for serial PSRAM/NAND/NOR, hyper RAM/Flash

Clock, reset, and supply management

- 2.7 V to 3.6 V application supply and I/O
- POR, PDR, and PVD
- Embedded regulator (LDO)
- Internal oscillators:
144 MHz HSI (with ± 1% accuracy over temperature range [-20°C : 130°C]),
160/144/100 MHz PSI,
32 kHz LSI
- External oscillators:
4 to 50 MHz HSE,
32.768 kHz LSE
- Low-power modes: Sleep, Stop, and Standby

DMA controller to offload the CPU

- 2 x LPDMA with 16 channels (8 + 8)

Analog

- 3 × 12-bit ADCs (28 external channels and 2 internal), up to 2.25 MSPS, or up to 4.5 MSPS in dual interleaved mode
- 1 × 12-bit DAC
- 1 × comparator

Product status	
STM32C5A3xxx	STM32C5A3CG STM32C5A3KG STM32C5A3MG STM32C5A3RG STM32C5A3VG STM32C5A3ZG

Up to 17 timers

- 7 × 16-bit (including 2 × 16-bit advanced motor control, 1 × low-power 16-bit timer available in Stop mode) and 4 × 32-bit timers
- 2 × watchdogs
- 1 × SysTick timer
- RTC with hardware calendar, alarms, and calibration

Communication interfaces

- Up to 2 × I2C FM+ interfaces (SMBus/PMBus)
- Up to 1 × I3C
- Up to 4 × USARTs (ISO7816 interface, LIN, IrDA, modem control), 3 × UARTs, and 1 × LPUART
- Up to 3 × SPIs with muxed with full-duplex I2S for audio class accuracy via external clock and up to 4 × additional SPIs from 4 × USARTs when configured in synchronous mode
- 2 × FDCANs
- 1 × USB 2.0 full-speed host and device
- Ethernet MAC interface with DMA controller

Low-power modes

- Sleep, Stop, and Standby modes

Up to 118 I/O ports with interrupt capability**Security**

- Two AES coprocessors, including one with DPA resistance, 128-bit and 256-bit key length
- HASH hardware accelerator (SHA-1, SHA-224, SHA-256, SHA-512, HMAC)
- Hardware unique key (HUK)
- Public key accelerator (PKA), DPA resistant
- True random number generator, NIST SP800-90B compliant
- 96-bit unique ID
- Flexible life-cycle scheme with RDP and password-protected regression

Mathematical coprocessor

- CORDIC for trigonometric functions acceleration

Bootloader support on USART, FDCAN, USB, and SPI interfaces

All packages are ECOPACK2 compliant.

1 Introduction

This document provides information on STM32C5A3xxx devices, such as description, functional overview, pin assignment and definition, electrical characteristics, packaging and ordering information.

For information on the Arm® Cortex®-M33 core, refer to the *Arm® Cortex®-M33 Processor Technical Reference Manual*, available from the www.arm.com website.



Note: *Arm and Cortex are registered trademarks of Arm Limited (or its subsidiaries or affiliates) in the US and/or elsewhere.*

The Arm word and logo are trademarks of Arm Limited (or its subsidiaries) in the US and/or elsewhere. All rights reserved.

2 Description

The STM32C5A3xxx devices are general purpose microcontrollers family (STM32C5 series) based on the high-performance Arm® Cortex®-M33 32-bit RISC core. They operate at a frequency of up to 144 MHz.

The Cortex®-M33 core features a single-precision floating-point unit (FPU) that supports all the Arm® single-precision data-processing instructions and all the data types.

The Cortex®-M33 core also implements a full set of digital signal processing (DSP) instructions and a memory protection unit (MPU) that enhances the application security.

The devices embed high-speed memories (up to 1 Mbyte flash memory and 128-Kbyte SRAM), one Octo-SPI memory interface, and an extensive range of enhanced I/Os, peripherals connected to three APB buses, three AHB buses, and a 32-bit multi-AHB bus matrix.

The devices feature several protection mechanisms for embedded flash memory and SRAM: readout protection, write protection, and hide protection areas.

The devices embed several peripherals reinforcing security:

- HASH hardware accelerator
- Hardware unique key (HUK)
- True random number generator
- Two AES coprocessors, including one with DPA resistance
- Public key accelerator (PKA), DPA resistant

The devices offer three 12-bit ADCs, one DAC channel, one comparator, a low-power RTC, four 32-bit general-purpose timers, two 16-bit PWM timers dedicated to motor control, four 16-bit general-purpose timers, two 16-bit basic timers, and one 16-bit low-power timer.

The devices also feature standard and advanced communication interfaces such as:

- Two I²Cs
- One I³C
- Three SPIs with muxed full-duplex I2S
- Four USARTs, three UARTs, and one low-power UART
- Two FDCANs
- One USB full-speed
- One Ethernet MAC interface and one single pair Ethernet

The devices operate in the -40 to +105 °C (+140 °C junction) temperature ranges from a 2.7 to 3.6 V power supply.

A comprehensive set of power-saving modes allows the design of low-power applications.

The devices offer multiple packages from 32 to 144 pins.

See [Table 1](#) for the list of peripherals available for each part number.

Table 1. Device features and peripheral counts

Peripherals	STM32C5A3KxT	STM32C5A3KxU	STM32C5A3CxT STM32C5A3CxU	STM32C5A3RxT	STM32C5A3MxT	STM32C5A3VxT	STM32C5A3zT
Number of pins	32	32	48	64	80	100	144
Flash memory (Mbytes)	1						
SRAM (Kbytes)	256						
ICACHE (Kbytes)	8						
Data flash memory (Kbytes)	64						
One-time-programmable (Kbytes)	4.5						
Octo-SPI interface	1						

Peripherals		STM32C5A3KxT	STM32C5A3KxU	STM32C5A3CxT STM32C5A3CxU	STM32C5A3RxT	STM32C5A3MxT	STM32C5A3VxT	STM32C5A3ZxT
Timers	General purpose	4 (32-bit) and 4 (16-bit)						
	Advanced-control	2						
	Basic	2 (16-bit)						
	Low-power	1 (16-bit)						
	SysTick	1						
	Watchdog	2						
Communication interfaces	SPI (with I2S)	3						
	I2C	2						
	I3C	1						
	USART	3			4			
	UART	2		3				
	LPUART	1						
	USB	1						
	FDCAN	2						
	Ethernet	No			Yes			
	TRACE	No			Yes			
CORDIC	Yes							
RTC	Yes (without LSE)			Yes				
Tamper pins	2		3					
True random number generator (RNG)	Yes							
HASH	Yes							
SAES, AES	Yes							
PKA	Yes							
GPIOs	25	27	38	52	66	86	118	
Wake-up pins	3		4	6		7		
12-bit ADC channels	9	10	11	17	22	28		
12-bit DAC channels	1							
Analog comparator	1							
Maximum CPU frequency (MHz)	144							
Operating voltage	2.7 V - 3.6 V							
Operating temperature	Junction temperature range: -40 to +140 °C							
Packages	LQFP32	UFQFPN32	LQFP48 UFQFPN48	LQFP64	LQFP80	LQFP100	LQFP144	

Figure 1 shows the general block diagram of the device family.

Figure 1. STM32C5A3xxx block diagram

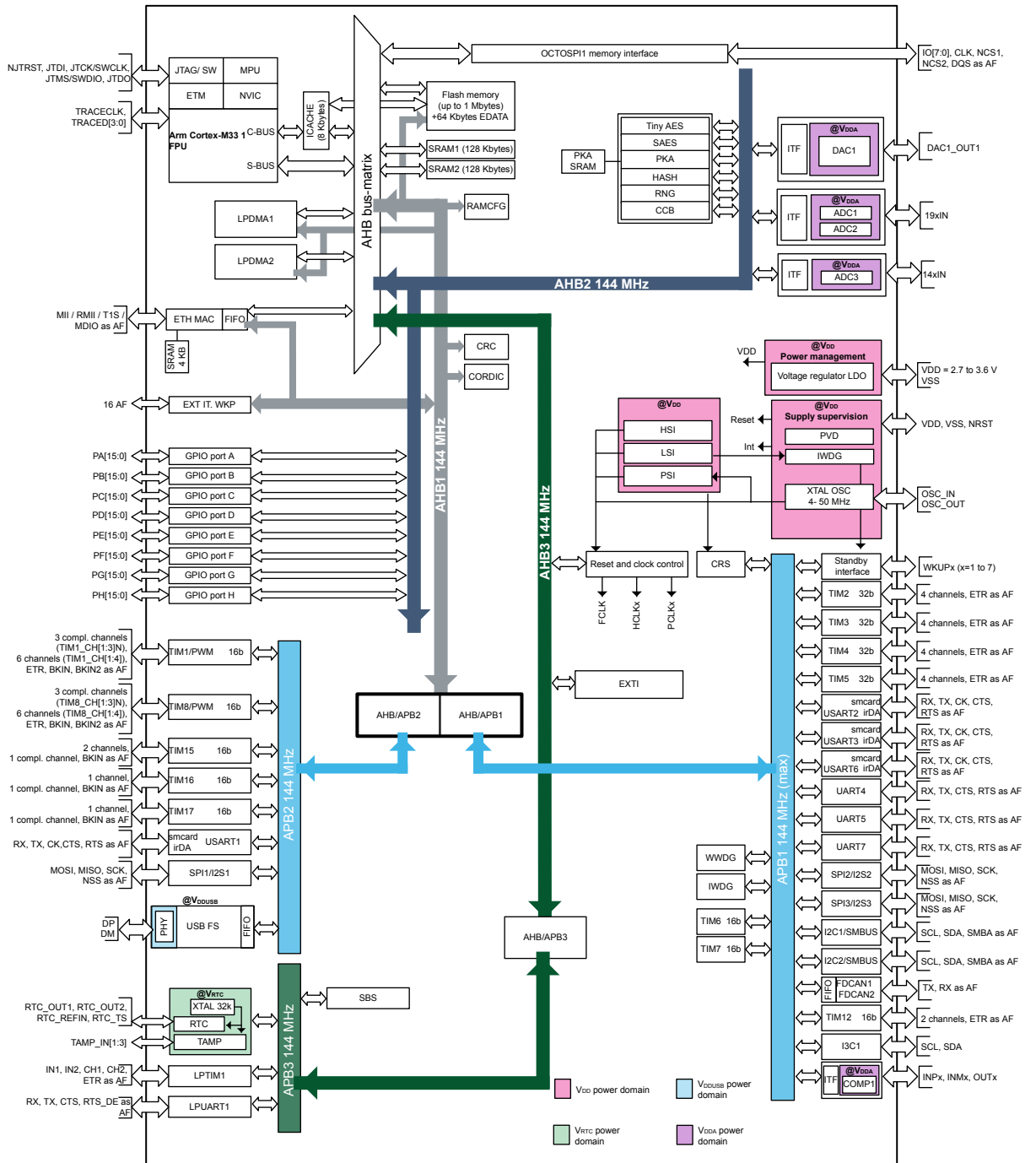

3 Functional overview

3.1 Arm® Cortex®-M33 with FPU

The Cortex®-M33 is a highly energy-efficient processor designed for microcontrollers and deeply embedded applications, especially those requiring efficient security.

The Cortex® processor delivers a high-computational performance with low-power consumption and an advanced response to interrupts.

It features:

- Memory protection units (MPUs) supporting eight regions
- Floating-point arithmetic functionality with support for single-precision arithmetic

The processor supports a set of DSP instructions that allows an efficient signal processing and a complex algorithm execution.

The Cortex®-M33 processor features:

- System AHB bus:
The system AHB (S-AHB) bus interface is used for any instruction fetch and data access to the memory-mapped SRAM, peripheral, or Vendor_SYS regions of the Armv8-M memory map.
- Code AHB bus:
The code AHB (C-AHB) bus interface is used for any instruction fetch and data access to the code region of the Armv8-M memory map.

Refer to [Figure 1. STM32C5A3xxx block diagram](#) for more details.

3.2 Instruction cache (ICACHE)

The instruction cache (ICACHE) is introduced on the C-AHB code bus of the Cortex[®]-M33 processor to improve performance when fetching instructions and data from internal memories. Some specific features, like hit-under-miss and critical-word-first refill policy, allow close to zero-wait-state performance in most use cases.

The ICACHE main features are:

- Bus interface:
 - One 32-bit AHB slave port, the execution port (input from Cortex[®]-M33 C-AHB code interface)
 - One 128-bit AHB master port: master1 port (output to Fast bus of the main AHB bus matrix)
 - One 32-bit AHB slave port for control (input from AHB peripherals interconnect, for ICACHE registers access)
- Cache access:
 - Zero wait-state on hits
 - Hit-under-miss capability: ability to serve processor requests (access to cached data) during an ongoing line refill due to a previous cache miss
 - Optimal cache line refill thanks to WRAPw bursts of the size of the cache line (32-bit word size, w, aligned on cache line size)
 - n-way set-associative default configuration with the possibility to configure as 1-way, meaning direct-mapped cache, for applications needing a very-low-power consumption profile
- Replacement and refill:
 - pLRU-t replacement policy (pseudo-least-recently-used, based on binary tree), algorithm with the best complexity/performance balance
 - Critical-word-first refill policy, minimizing processor stalls
 - Possibility to configure burst type of AHB memory transaction for remapped regions: INCRw or WRAPw (size w aligned on cache line size)
- Performance counters:

The ICACHE implements two performance counters:

 - Hit monitor counter (32-bit)
 - Miss monitor counter (16-bit)
- Error management:
 - Possibility to detect an unexpected cacheable write access, to flag an error, and optionally to raise an interrupt
- Maintenance operation:
 - Cache invalidate: full cache invalidation, fast command, noninterruptible

3.3 Memory protection unit

The memory protection unit (MPU) is used to manage the CPU accesses to the memory. It also prevents one task to accidentally corrupt the memory or the resources used by any other active task. This memory area is organized into up to eight protected areas.

The MPU is especially helpful for applications where some critical or certified code must be protected against the misbehavior of other tasks. An RTOS (real-time operating system) usually manages the MPU.

If a program accesses a memory location that is prohibited by the MPU, the RTOS can detect it and take action. In an RTOS environment, the kernel can dynamically update the MPU area setting based on the process to be executed.

3.4 Memories

3.4.1 Embedded flash memory

The devices feature up to 1 Mbyte embedded flash memory that is available for storing programs and data.

The flash memory interface features:

- Dual-bank operating modes
- Read-while-write (RWW)

This allows a read operation to be performed from one bank while an erase or program operation is performed to the other bank. Each bank contains 64 pages of 8 Kbytes.

The flash memory embeds 2-Kbyte OTP (one-time programmable) for user data.

Enhanced flash memory protection mechanisms are available. These mechanisms can be activated by option bytes:

- RDP states for protecting memory content from debug access
- Page group write-protection (WRPG)
- One hide protection area (HDP) per bank that provides temporal isolation for startup code

The whole nonvolatile memory embeds the error correction code (ECC) feature supporting:

- Single-error detection and correction
- Double-error detection
- ECC fail address report

3.4.1.1 **User data flash memory**

The device features 64 Kbytes of user data flash memory split in two banks of 16 × 2-Kbyte sectors offering perfect space for storing EEPROM emulation data.

3.4.2 **Embedded SRAMs**

Two SRAMs are embedded in the STM32C5A3xxx devices.

These SRAMs are made of several blocks that can be powered down in Stop mode to reduce consumption:

- SRAM1: 128 Kbytes
- SRAM2: 128 Kbytes with optional ECC

3.5 **Boot modes**

At startup, the BOOT0 pin allows the system to boot either from the user Flash or from the bootloader.

When boot from user Flash is selected, BOOTADD defines the boot address. This address can be locked thanks to BOOT_LOCK.

The embedded bootloader is located in the system memory, programmed by STMicroelectronics during production. It is used to reprogram the flash memory by using USART, SPI, FDCAN, or USB in device mode through the device firmware upgrade (DFU).

Refer to the application note *STM32 microcontroller system memory boot mode* (AN2606) for more details.

3.6 **Power supply management**

The power controller (PWR) main features are:

- Power supplies and supply domains
 - Core domain (VCORE)
 - VDD domain
 - RTC domain
 - Analog domain (VDMA)
- System supply voltage regulation
 - Voltage regulator (LDO)
- Power supply supervision
 - POR/PDR monitor
 - PVD monitor
- Power management
 - Low-power modes
- Privileged protection

3.6.1 Power supply schemes

The devices require a 2.7 V to 3.6 V V_{DD} operating voltage supply.

- $V_{DD} = 2.7\text{ V to }3.6\text{ V}$
 V_{DD} is the external power supply for the I/Os, the internal regulator, and the system analog such as reset, power management, and internal clocks. It is provided externally through the VDD pins.
- $V_{DDA} = V_{DD}$
 V_{DDA} is the analog power supply for ADCs, DACs, and comparator.
- V_{REF-}, V_{REF+}
 V_{REF+} is the input reference voltage for ADCs and DAC.
 V_{REF+} can be grounded when ADCs and DAC are not active.
 V_{REF-} and V_{REF+} pins are not available on all packages. When not available, they are bonded to VSSA and VDDA, respectively.

The STM32C5A3xxx devices embed a LDO regulator to provide the V_{CORE} supply for digital peripherals, SRAM1, SRAM2, and embedded flash memory. The LDO generates this voltage on VCAP pin connected to an external capacitor of 2.2 μF typical.

The LDO regulator can operate in Stop modes where it may provide two different voltages (voltage scaling).

Figure 2. STM32C5A3xxx power supply overview

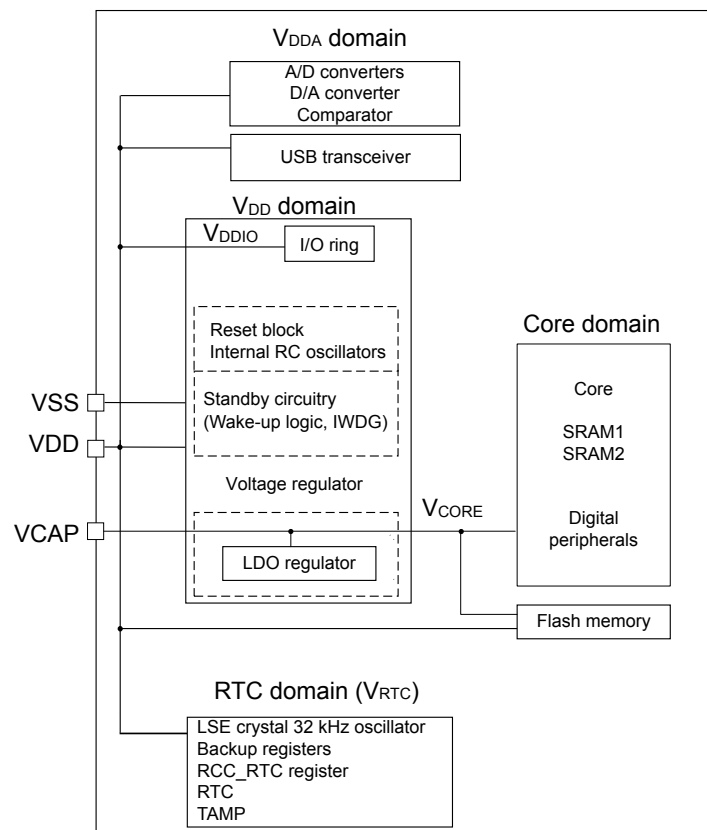

DT74255V2

3.6.2 Power supply supervisor

The devices have an integrated power-on reset (POR) / power-down reset (PDR) circuitry:

- **Power-on reset (POR)**
The POR supervisor monitors the V_{DD} power supply and compares it to a fixed threshold. The devices remain in reset mode when V_{DD} is below this threshold.
- **Power-down reset (PDR)**
The PDR supervisor monitors the V_{DD} power supply. A reset is generated when V_{DD} drops below a fixed threshold.
- **Programmable voltage detector (PVD)**
The PVD monitors the V_{DD} power supply by comparing it with a threshold fixed by hardware. An interrupt can be generated when V_{DD} drops below the VPVD threshold and/or when V_{DD} is higher than the VPVD threshold. The interrupt service routine can then generate a warning message and/or put the device into a safe state. The software enables the PVD.

3.6.3 Low-power modes

By default, the microcontroller is in Run mode after a system or a power reset. It is up to the user to select one of the low-power modes described below:

- **Sleep mode**
In Sleep mode, only the CPU is stopped. All peripherals continue to operate and can wake up the CPU when an interrupt/event occurs.
- **Stop mode**
Stop mode achieves the lowest power consumption while retaining the content of SRAM and registers. All clocks in the VCORE domain are stopped, the PSI, the HSI, and the HSE crystal oscillators are disabled. The LSE or LSI is still running.
The RTC can remain active (Stop mode with RTC, Stop mode without RTC).
The system clock when exiting Stop mode is HSI 144 MHz.
Stop 0 mode maintains the regulator output at a nominal voltage of 1.2 V.
Stop 1 mode reduces power consumption by lowering V_{CORE} to 0.95 V, which results in a longer wake-up time and fewer wake-up sources compared to Stop 0 mode.
- **Standby mode**
The Standby mode is used to achieve the lowest power consumption with BOR.
The PSI, the HSI, and the HSE crystal oscillators are also switched off.
The RTC can remain active (Standby mode with RTC, Standby mode without RTC).
The state of each I/O during Standby mode can be retained.
After entering Standby mode, SRAMs and register contents are lost except for registers in the RTC domain and Standby circuitry.
The device exits Standby mode in the following cases:
 - An external reset with NRST pin
 - An IWDG reset
 - A WKUP pin event (configurable rising or falling edge)
 - An RTC event occurs (alarm, periodic wake-up, timestamp), or in a tamper detection. The tamper detection can be raised either due to external pins or due to an internal failure detection.
 The system clock after wake-up is HSI at 144 MHz.

3.6.4 Reset mode

To improve the consumption under reset, the I/O state under and after reset is “analog state” (the I/O Schmitt trigger is disabled).

3.7 Peripheral interconnect matrix

Several peripherals have direct connections between them. These connections allow autonomous communication between them and support the saving of CPU resources (thus power supply consumption). In addition, these hardware connections allow fast and predictable latency.

Depending on the peripherals, these interconnections can operate in Run and Sleep modes.

3.8 Reset and clock controller (RCC)

The clock controller distributes the clocks coming from the different oscillators to the core and to the peripherals. It also manages the clock gating for low-power modes and ensures the clock robustness.

It features:

- **Clock prescaler:** in order to get the best trade-off between speed and current consumption, the clock frequency to the CPU and peripherals can be adjusted by a programmable prescaler.
- **Clock security system:** clock sources can be changed safely on the fly in Run mode through a configuration register.
- **Clock management:** in order to reduce the power consumption, the clock controller can stop the clock to the core, individual peripherals, or memory.
- **System clock source:** four different clock sources can be used to drive the master clock SYSCLK:
 - 4 to 50 MHz high-speed external crystal or ceramic resonator (HSE). The HSE can also be configured in bypass mode for an external clock.
 - 144 MHz or 48 MHz on high-speed internal RC oscillator (HSI), trimmable by software
 - 144 MHz programmable-speed internal oscillator (PSI)
- **Auxiliary clock source:** two ultra-low-power clock sources that can be used to drive the real-time clock:
 - 32.768 kHz low-speed external crystal (LSE), supporting four drive capability modes. The LSE can also be configured in bypass mode for an external clock.
 - 32 kHz low-speed internal RC (LSI), also used to drive the independent watchdog.
- **Peripheral clock sources:** several peripherals have their own independent clock whatever the system clock. Two dividers, each with a large scale of configurable division factors, can generate independent clocks for the ADCS, USARTx, UARTx, SPIx, I2Cx, I3C1, and FDCANx.
- **Startup clock:** after reset, the microcontroller restarts by default with an internal 144 MHz clock (HSI). The prescaler ratio and clock source can be changed by the application program as soon as the code execution starts.
- **Clock security system (CSS):** this feature can be enabled by software. If an HSE clock failure occurs, the master clock automatically switches to HSI and a software interrupt is generated if enabled. LSE failure can also be detected and generates an interrupt.
- **Clock-out capability:**
 - MCO (microcontroller clock output): it outputs one of the internal clocks for external use by the application.
 - LSCO (low-speed clock output): it outputs LSI or LSE in all low-power modes.

Several prescalers allow AHB and APB frequencies configuration. The maximum frequency of the AHB and the APB clock domains is 144 MHz.

3.9 Clock recovery system (CRS)

The devices embed a special block that allows automatic trimming of the internal 144 MHz oscillator to guarantee its optimal accuracy over the whole device-operational range. This automatic trimming is based on the external synchronization signal. This signal is either derived from USB_SOF signalization, from an LSE oscillator, from an external signal on the CRS_SYNC pin or generated by user software. For faster lock-in during startup, automatic-trimming and manual-trimming action can be combined.

3.10 General-purpose inputs/outputs (GPIOs)

Each of the GPIO pins can be configured by software as output (push-pull or open-drain), as input (with or without pull-up or pull-down) or as peripheral alternate function. Most of the GPIO pins are shared with digital or analog alternate functions.

After reset, all GPIOs are in Analog mode to reduce power consumption.

The I/Os alternate function configuration can be locked if needed following a specific sequence in order to avoid spurious writing to the I/Os registers.

3.11 Multi-AHB bus matrix

A 32-bit multi-AHB bus matrix interconnects all the masters (CPU, LPDMA1, LPDMA2) and the slave peripherals (flash memory, SRAMs, AHB, and APB). It also ensures a seamless and efficient operation even when several high-speed peripherals work simultaneously.

3.12 Low-power direct memory access controller (LPDMA)

The low-power direct memory access (LPDMA) controller is a bus master and system peripheral. The LPDMA is used to perform programmable data transfers between memory-mapped peripherals and/or memories via linked-lists, under the control of an off-loaded CPU.

The LPDMA main features are:

- Single bidirectional AHB master
- Memory-mapped data transfers from a source to a destination:
 - Peripheral to memory
 - Memory to peripheral
 - Memory to memory
 - Peripheral to peripheral
- Transfers arbitration based on a 4-grade programmed priority at the channel level:
 - One high-priority traffic class for time-sensitive channels (queue 3)
 - Three low-priority traffic classes with a weighted round-robin allocation for non-time-sensitive channels (queues 0, 1, 2)
- Per channel event generation on any of the following events: transfer complete, half transfer complete, data transfer error, user setting error, link transfer error, completed suspension, and trigger overrun
- 16 concurrent LPDMA channels (8-channel LPDMA1, 8-channel LPDMA2):
 - Intrachannel LPDMA transfers chaining via programmable linked-list into memory, supporting two execution modes: run-to-completion and link step mode
 - Intrachannel and interchannel LPDMA transfers chaining via programmable LPDMA input triggers connection to LPDMA task completion events
- Per linked-list item within a channel:
 - Separately programmed source and destination transfers
 - Programmable data handling between source and destination: byte-based padding or truncation, sign extension, and left/right realignment
 - Programmable number of data bytes to be transferred from the source, defining the block level
 - Linear source and destination addressing: either fixed or contiguously incremented addressing, programmed at a block level, between successive single transfers
 - Programmable LPDMA request and trigger selection
 - Programmable LPDMA half-transfer and transfer-complete events generation
 - Pointer to the next linked-list item and its data structure in memory, with automatic update of the LPDMA linked-list control registers
- Debug:
 - Channel suspend and resume support
 - Channel status reporting and event flags
- Privileged/unprivileged support:
 - Support for privileged and unprivileged LPDMA transfers, independently at the channel level
 - Privileged-aware AHB slave port

Table 2. LPDMA1 and LPDMA2 channels implementation and usage

Channel x	Hardware parameters		Features
	dma_fifo_size[x]	dma_addressing[x]	
x = 0 to 7	0	0	Channel x (x = 0 to 7) is implemented with: <ul style="list-style-type: none"> • no FIFO. Only a single source transfer cell is internally registered. • fixed/contiguously incremented addressing

Table 3. LPDMA1 and LPDMA2 autonomous mode and wake-up in low-power modes

Feature	Low-power modes
Wake-up	LPDMA1/2 in Sleep mode

3.13 Interrupts and events

3.13.1 Nested vectored interrupt controller (NVIC)

- 98 maskable interrupt channels (not including the 16 Cortex[®]-M33 with FPU interrupt lines)
- 16 programmable priority levels (4 bits of interrupt priority used)
- Low-latency exception and interrupt handling
- Power management control
- Implementation of system control registers

The NVIC and the processor core interface are closely coupled, enabling low-latency interrupt processing and efficient processing of late-arriving interrupts. All interrupts, including the core exceptions, are managed by the NVIC.

3.13.2 Extended interrupt and event controller (EXTI)

The extended interrupts and event controller (EXTI) manages the individual CPU and system wake-up through configurable and direct event inputs. It provides wake-up requests to the power control and generates an interrupt request to the CPU NVIC and events to the CPU event input. For the CPU, an additional event generation block (EVG) is needed to generate the CPU event signal.

The EXTI wake-up requests allow the system to wake up from Stop modes.

The interrupt request and event request generation can also be used in Run modes.

The EXTI also includes the EXTI mux I/O port selection.

The EXTI main features are the following:

- 40 input events are supported.
- All event inputs allow the possibility to wake up the system.
- Events that do not have an associated wake-up flag in the peripheral have a flag in the EXTI and generate an interrupt to the CPU from the EXTI.
- Events can be used to generate a CPU wake-up event.

The asynchronous event inputs are classified into two groups:

- Configurable events (signals from I/Os or peripherals able to generate a pulse), with the following features:
 - Selectable active trigger edge
 - Interrupt pending status register bits independent for the rising and falling edge
 - Individual interrupt and event generation mask, used for conditioning the CPU wake-up, interrupt, and event generation
 - Software trigger possibility
 - EXTI I/O port selection
- Direct events (interrupt and wake-up sources from peripherals having an associated flag which requires to be cleared in the peripheral), with the following features:
 - Fixed rising edge active trigger
 - No interrupt pending status register bit in the EXTI (the interrupt pending status flag is provided by the peripheral generating the event)
 - Individual interrupt and event generation mask, used to condition the CPU wake-up and event generation
 - No software trigger possibility

3.14 Cyclic redundancy check calculation unit (CRC)

The cyclic redundancy check calculation unit (CRC) calculation unit is used to get a CRC code from 8-, 16-, or 32-bit data word and a generator polynomial.

Among other applications, CRC-based techniques are used to verify data transmission or storage integrity. In the scope of the functional safety standards, they offer a means of verifying the flash memory integrity. The CRC calculation unit helps compute a signature of the software during runtime, to be compared with a reference signature generated at link time and stored at a given memory location.

3.15 Extended-SPI interface (XSPI)

The XSPI supports most external serial memories such as serial PSRAMs, serial NAND, and serial NOR flash memories, HyperRAM™ and HyperFlash™ memories, with the following functional modes:

- Indirect mode: All the operations are performed using the XSPI registers to preset commands, addresses, data, and transfer parameters.
- Automatic status-polling mode: The external memory status register is periodically read, and an interrupt can be generated in case of flag setting. This feature is only available in regular-command protocol.
- Memory-mapped mode: The external memory is memory mapped and is seen by the system as if it were an internal memory, supporting both read and write operations.

The XSPI supports the following protocols with associated frame formats:

- The regular-command frame format with the command, address, alternate byte, dummy cycles, and data phase
- The HyperBus™ frame format

The XSPI main features are:

- Functional modes: indirect, automatic status-polling, and memory-mapped
- Read and write support in memory-mapped mode
- External (P)SRAM memory support
- Support for single, dual, quad, and octal communication
- Dual-memory configuration, where eight bits can be sent/received simultaneously by accessing two quad memories in parallel
- SDR (single-data rate) and DTR (double-transfer rate) support
- Data strobe support
- Fully programmable opcode
- Fully programmable frame format
- Support for wrapped-type access to memory in the read direction
- HyperBus support
- Integrated FIFO for reception and transmission
- Asynchronous bus clock versus kernel clock support
- 8-, 16-, and 32-bit data accesses allowed
- DMA protocol support
- DMA channel for indirect mode operations
- Interrupt generation on FIFO threshold, timeout, operation complete, and access error
- XSPI interface with transaction acceptance limited to one: The interface accepts the next transfer on the AHB bus only once the previous is completed on the memory side.
- Dual chip select support (NCS1 and NCS2)
- Extended external memory support: If two same-size external memories (extmem1 and extmem2) are connected to the same I/O port, contiguously in the memory map and driven by a single XSPI, this XSPI automatically switches CS to extmem1 or extmem2 according to the address on the interconnect side.
- Possibility to disable the automatic prefetch

3.16 Delay block (DLYB)

The delay block (DLYB) is used to generate an output clock that is dephased from the input clock. The phase of the output clock must be programmed by the user application. The output clock is then used to clock the data received by another peripheral such as an XSPI interface. The delay is voltage- and temperature-dependent, which may require the application to reconfigure and recenter the output clock phase with the received data.

The delay block has the following features:

- Input clock frequency ranging from 25 MHz to the maximum frequency supported by the communication interface
- Up to 12 oversampling phases

3.17 Analog-to-digital converter (ADC)

The devices embed up to two analog-to-digital converters (ADC).

- ADC1 and ADC2 are tightly coupled and can operate in dual mode (ADC1 is the master).
- ADC3 is controlled independently.

Each ADC consists of one 12-bit successive approximation analog-to-digital converter. Each ADC has up to 14 multiplexed channels. A/D conversion of the various channels can be performed in single, continuous, scan, or discontinuous mode. The result of the ADC is stored in a left-aligned or right-aligned (default configuration) 32-bit data register.

The ADCs are mapped on the AHB bus to allow fast data handling. The analog watchdog features allow the application to detect if the input voltage goes outside the user-defined high or low thresholds.

A built-in hardware oversampler improves analog performance while off-loading the related computational burden from the CPU. An efficient low-power mode is implemented to allow very low consumption at low frequency.

The ADC main features are:

- High-performance features:
 - Up to two ADCs which can operate in dual mode
 - ADC1 is connected to 12 external channels and two internal channels.
 - ADC2 is connected to 14 external channels.
 - ADC3 is connected to 14 external channels.
 - 12, 10, 8, or 6-bit configurable resolution
 - ADC conversion time independent from the AHB bus clock frequency
 - Faster conversion time by lowering resolution
 - AHB slave bus interface to allow fast data handling
 - Channel-wise programmable sampling time
 - Flexible sampling time control
 - Fixed latency for a trigger to start of sampling
 - Up to four injected channels (analog inputs assignment to regular or injected channels is fully configurable)
 - Data alignment with in-built data coherency
 - Data can be managed by DMA for regular channel conversions
 - Four dedicated data registers for the injected channels
- Low-power features:
 - Speed adaptive low-power mode to reduce ADC consumption when operating at low frequency
 - Allows slow bus frequency application while keeping optimum ADC performance
 - Provides automatic control to avoid ADC overrun in low AHB bus clock frequency application (autodelayed mode)
- Oversampler:
 - 32-bit data register
 - Oversampling ratio adjustable from 2 to 1024
 - Programmable data right and left shifts
- Data preconditioning:
 - Gain compensation
 - Offset compensation
- Analog input channels:
 - External analog inputs (per ADC): up to 14 GPIO pads
 - One channel for the internal reference voltage (V_{REFINT})
 - One channel for the internal temperature sensor (V_{SENSE})
- Start-of-conversion can be initiated:
 - By software for both regular and injected conversions
 - By hardware triggers with configurable polarity (internal timer events or GPIO input events) for both regular and injected conversions
- Conversion modes:
 - Each ADC can convert a single channel or can scan a sequence of channels
 - Single mode converts selected inputs once per trigger
 - Continuous mode converts selected inputs continuously
 - Discontinuous mode
- Interrupt generation at ADC ready, the end of sampling, the end of conversion (regular or injected), end of sequence conversion (regular or injected), analog watchdog 1, 2, or 3, or overrun events
- Three analog watchdogs per ADC
- ADC input range: $V_{SSA} \leq V_{IN} \leq V_{REF+}$

Table 4. ADC features

ADC modes/features	ADC1	ADC2	ADC3
Resolution		12 bits	
Maximum sampling-speed		2 Msps	
Hardware-offset calibration		X	
Single-ended inputs		X	
Injected channel conversion		X	
Oversampling		up to x1024	
Data register		32 bits	
DMA support		X	
Offset compensation		X	
Gain compensation		X	
Number of analog watchdogs		3	

3.17.1 Analog temperature sensor

The STM32C5A3xxx embed an analog temperature sensor that generates a voltage V_{SENSE} that varies linearly with temperature. The temperature sensor is internally connected to the ADC input channel that is used to convert the sensor output voltage into a digital value.

The sensor provides good linearity but it must be calibrated to obtain a good accuracy of the temperature measurement. As the offset of the temperature sensor varies from chip to chip due to process variation, the uncalibrated internal temperature sensor is suitable for applications that detect temperature changes only.

To improve the accuracy of the temperature sensor measurement, each device is individually factory-calibrated by STMicroelectronics. The temperature sensor factory calibration data are stored by STMicroelectronics in the system memory area, accessible in read-only mode.

3.17.2 Internal voltage reference (V_{REFINT})

The V_{REFINT} provides a stable (bandgap) voltage output for the ADC and the comparator. It is internally connected to ADC input channel.

The precise voltage of V_{REFINT} is individually measured for each part by STMicroelectronics during production test and stored in the system memory area. It is accessible in read-only mode.

3.18 Digital to analog converter (DAC)

The DAC module is a 12-bit, voltage output digital-to-analog converter. The DAC can be configured in 8- or 12-bit mode and can be used in conjunction with the DMA controller. In 12-bit mode, the data may be left-aligned or right-aligned.

An input reference pin, V_{REF+} (shared with others analog peripherals) is available for better resolution.

The DAC_OUTx pin can be used as general-purpose input/output (GPIO) when the DAC output is disconnected from the output pad and connected to the on chip peripheral. The DAC output buffer can be optionally enabled to allow a high drive output current. An individual calibration can be applied DAC output channel. The DAC output channels support a low-power mode, the sample and hold mode.

The DAC main features are::

- One DAC interface, two output channels
- Left or right data alignment in 12-bit mode
- Synchronized update capability
- Noise-wave and triangular-wave generation
- DMA capability for each channel including DMA underrun error detection
- Double-data DMA capability to reduce the bus activity
- External triggers for conversion
- DAC output-channel buffered/unbuffered modes
- Buffer offset calibration
- DAC output can be disconnected from the DAC_OUTx output pin
- DAC output connection to on chip peripherals
- Sample and hold mode for low-power operation in Stop mode
- Voltage reference input from VREF+ pin

3.19 Ultralow-power comparator (COMP)

The device embeds an ultralow-power comparator (COMP). It can be used for a variety of functions including:

- Wake-up from low-power mode triggered by an analog signal
- Analog signal conditioning
- Cycle-by-cycle current control loop when combined with a PWM output from a timer

The COMP main features are:

- Selectable inverting analog inputs:
 - I/O pins
 - DAC channel output
 - Internal reference voltage and three submultiple values (1/4, 1/2, 3/4) provided by the scaler (buffered voltage divider)
- I/O pins selectable as noninverting analog inputs
- Programmable hysteresis
- Programmable speed/consumption
- Mapping of outputs to I/Os
- Redirection of outputs to timer inputs for triggering:
 - Capture events
 - OCREF_CLR events (for cycle-by-cycle current control)
 - Break events for fast PWM shutdowns
- Blanking of comparator outputs
- Interrupt generation capability with wake-up from Sleep and Stop modes (through the EXTI controller)
- Direct interrupt output to the CPU

3.20 Coupling and chaining bridge (CCB)

The coupling and chaining bridge (CCB) can be programmed to implement special coupling and chaining operations required to protect private keys used in PKA-protected operations.

These coupling and chaining operations involve the PKA, the SAES, and sometimes the RNG peripherals.

The CCB main features are:

- AHB system slave port, mapping multiple peripherals
- AHB configuration slave port (CCB peripheral)
 - All read accesses supported
 - For writes 32-bit word accesses only, otherwise, an AHB error occurs
- Support for coupling PKA RAM writes to SAES input data register
- Support for read and write chaining between PKA RAM and SAES
- Support for SAES to CCB read chaining, with comparison to a 128-bit reference tag
- Support for RNG output chaining with either PKA RAM or SAES_IVR registers
- Dedicated sequences to support three PKA-protected operations (modular exponentiation, scalar multiplication, ECDSA signature)
 - One-time sequence to prepare a PKA-protected operation (blob creation)
 - Many-time sequence to execute PKA-protected operation (blob usage)
- Optional private key generation for ECDSA signature and for ECC private key cryptography (key never accessible to the application in clear text)
- Possibility to encrypt, with AES-256, any PKA blob encryption key using the device unique secret key DHUK (in the SAES), which makes the PKA encrypted blob usable only on this device.
- Software reset capability
- Repository for cryptographic subsystem tamper event flags

3.21 True random number generator (RNG)

The RNG is a true random number generator that provides full entropy outputs to the application as 32-bit samples. It is composed of a live entropy source (analog) and an internal conditioning component.

The RNG is a NIST SP 800-90B compliant entropy source that can be used to construct a nondeterministic random bit generator (NDRBG).

The RNG can be certified NIST SP800-90B. It has also been tested using the German BSI statistical tests of AIS-31 (T0 to T8).

The RNG main features are the following:

- The RNG delivers 32-bit true random numbers, produced by an analog entropy source conditioned by a NIST SP800-90B approved conditioning stage.
- It can be used as the entropy source to construct a nondeterministic random bit generator (NDRBG).
- In the NIST configuration, it produces four 32-bit random samples every 412 AHB clock cycles if $f_{AHB} < f_{threshold}$ (256 RNG clock cycles otherwise).
- It embeds startup and NIST SP800-90B approved continuous health tests (repetition count and adaptive proportion tests), associated with specific error management.
- It can be disabled to reduce power consumption, or enabled with an automatic low power mode (default configuration).
- It has an AMBA® AHB slave peripheral, accessible through 32-bit word single accesses only (else an AHB bus error is generated, and the write accesses are ignored).

3.22 AES hardware accelerator (AES)

The AES hardware accelerator (AES) encrypts or decrypts data in compliance with the advanced encryption standard (AES) defined by NIST.

AES supports ECB, CBC, CTR, GCM, GMAC, and CCM chaining modes for key sizes of 128 or 256 bits.

AES can load the key stored in the SAES peripheral by hardware, under SAES control.

The peripheral supports DMA single transfers for incoming and outgoing data (two DMA channels are required).

The AES main features are:

- Compliant with NIST FIPS publication 197 “Advanced encryption standard (AES)” (November 2001)
- Encryption and decryption with multiple chaining modes:
 - Electronic codebook (ECB) mode
 - Cipher block chaining (CBC) mode
 - Counter (CTR) mode
 - Galois counter mode (GCM)
 - Galois message authentication code (GMAC) mode
 - Counter with CBC-MAC (CCM) mode
- 128-bit data block processing, supporting cipher key lengths of 128-bit and 256-bit
 - 51 or 75 clock cycle latency in ECB mode for processing one 128-bit block with, respectively, 128-bit or 256-bit key
- Integrated key scheduler to compute the last round key for ECB/CBC decryption
- 256-bit write-only registers for storing cryptographic keys (eight 32-bit registers)
- 128-bit registers for storing initialization vectors (four 32-bit registers)
- 32-bit buffer for data input and output
- Automatic data flow control supporting two direct memory access (DMA) channels, one for incoming data, one for processed data. Only single transfers are supported.
- Data-swapping logic to support 1-, 8-, 16-, or 32-bit data
- AMBA AHB slave peripheral, accessible through 32-bit word single accesses only. Other access types generate an AHB error, and other than 32-bit writes may corrupt the register content.
- Software (in CPU mode only, not in DMA mode) can suspend a message if AES needs to process another message with a higher priority, then resume the original message.

Table 5. AES features

Modes or features ⁽¹⁾	AES	SAES
ECB, CBC chaining	X	X
CTR, CCM, GCM chaining	X	X
AES 128-bit ECB encryption in cycles	51	480
DHUK and BHK key selection	-	X
Resistant to side-channel attacks	-	X
Shared key between SAES and AES	X	
Key sizes in bits	128/256	128/256

1. X = Supported.

3.23 Secure AES coprocessor (SAES)

The secure AES coprocessor (SAES) encrypts or decrypts data in compliance with the advanced encryption standard (AES) defined by NIST. It incorporates protection against side-channel attacks (SCA), including differential power analysis (DPA), certified SESIP, and PSA security assurance level 3.

SAES supports ECB, CBC, CTR, GCM, GMAC, and CCM chaining modes for key sizes of 128 or 256 bits, as well as special modes such as hardware secret key encryption/decryption (wrapped-key mode) and key sharing with a faster AES peripheral (shared-key mode).

SAES can load STM32 hardware secret master keys (boot hardware key BHK and derived hardware unique key DHUK) by hardware, usable but not readable by the application.

The peripheral supports DMA single transfers for incoming and outgoing data (two DMA channels are required). It is hardware-linked with the true random number generator (RNG) and the AES peripheral.

The SAES main features are:

- Compliant with NIST FIPS publication 197 “Advanced encryption standard (AES)” (November 2001)
- Encryption and decryption with multiple chaining modes:
 - Electronic codebook (ECB) mode
 - Cipher block chaining (CBC) mode
 - Counter (CTR) mode
 - Galois counter mode (GCM)
 - Galois message authentication code (GMAC) mode
 - Counter with CBC-MAC (CCM) mode
- Protection against side-channel attacks (SCA), including differential power analysis (DPA), certified SESIP, and PSA security assurance level 3
- 128-bit data block processing, supporting cipher key lengths of 128-bit and 256-bit
 - 480 or 680 clock cycle latency in ECB mode for processing one 128-bit block with, respectively, 128-bit or 256-bit key
- Hardware secret key encryption/decryption (wrapped-key mode)
- Using a dedicated key bus, optional key sharing with a faster AES peripheral (shared-key mode), controlled by SAES
- Integrated key scheduler to compute the last round key for ECB/CBC decryption
- 256-bit of write-only registers for storing cryptographic keys (eight 32-bit registers)
 - Optional 128-bit or 256-bit hardware loading of two hardware secret keys (BHK, DHUK) that can be XOR-ed together
- Security context enforcement for keys
- 128-bit of registers for storing initialization vectors (four 32-bit registers)
- 32-bit buffer for data input and output
- Automatic data flow control supporting two direct memory access (DMA) channels, one for incoming data, one for processed data. Only single transfers are supported.
- Data-swapping logic to support 1-, 8-, 16-, or 32-bit data
- AMBA AHB slave peripheral, accessible through 32-bit word single accesses only. Other access types generate an AHB error, and other than 32-bit writes may corrupt the register content.
- Possibility for software (in CPU mode only, not in DMA mode) to suspend a message if AES needs to process another message with a higher priority, then resume the original message.

Table 6. AES versus SAES features

Modes or features ⁽¹⁾	AES	SAES
ECB, CBC chaining	X	X
CTR, CCM, GCM chaining	X	X
AES 128-bit ECB encryption in cycles	51	480
DHUK and BHK key selection	-	X
Resistant to side-channel attacks	-	X
Shared key between SAES and AES	X	
Key sizes in bits	128/256	128/256

1. X = supported.

3.24 HASH processor (HASH)

The hash processor is a fully compliant implementation of the secure hash algorithm (SHA-1, SHA-2 family) and the HMAC (keyed-hash message authentication code) algorithm. HMAC is suitable for applications requiring message authentication.

The hash processor computes FIPS (Federal Information Processing Standards) approved digests of lengths of 160, 224, and 256 bits for messages of any length less than 2×64 bits (for SHA-1, SHA-224, and SHA-256) or less than 2×128 bits (for SHA-384, SHA-512).

The HASH main features are:

- Suitable for data authentication applications, compliant with:
 - Federal Information Processing Standards Publication FIPS PUB 180-4, Secure Hash Standard (SHA-1 and SHA-2 family)
 - Federal Information Processing Standards Publication FIPS PUB 186-4, Digital Signature Standard (DSS)
 - Internet Engineering Task Force (IETF) Request For Comments RFC 2104, HMAC: Keyed-Hashing for Message Authentication and Federal Information Processing Standards Publication FIPS PUB 198-1, The Keyed-Hash Message Authentication Code (HMAC)
- Fast computation of SHA-1, SHA2-224, SHA2-256, SHA2-384, and SHA2-512:
 - 82 (respectively 66) clock cycles for processing one 512-bit block of data using SHA-1 (respectively SHA-256) algorithm
 - 98 clock cycles for processing one 1024-bit block of data using either SHA2-384 or SHA2-512 algorithm
 - Support for SHA-2 truncated outputs (SHA2-512/224, SHA2-512/256)
- Support for HMAC mode with all supported algorithms
- Corresponding 32-bit words of the digest from consecutive message blocks are added to each other to form the digest of the whole message.
 - Automatic 32-bit word swapping to comply with the internal little-endian representation of the input bit-string
 - Supported word swapping format: bits, bytes, half-words, and 32-bit words
- Single 32-bit, write-only, input register associated with an internal input FIFO, corresponding to a 64-byte block size (16 × 32 bits)
- Automatic padding to complete the input bit string to fit the digest minimum block size
- AHB slave peripheral, accessible by 32-bit words only (else an AHB error is generated)
- 8 × 32-bit words (H0 to H15) for output message digest
- Automatic data flow control supporting direct memory access (DMA) using one channel
- Support for both single and fixed DMA burst transfers of four words
- Interruptible message digest computation, on a per-block basis
 - Reloadable digest registers
 - Hashing computation suspend/resume mechanism, including DMA

3.25 Public key accelerator (PKA)

The public key accelerator (PKA) is intended for the computation of cryptographic public key primitives, specifically those related to RSA, Diffie-Hellmann, or ECC (elliptic curve cryptography) over GF(p) (Galois fields). To achieve high performance at a reasonable cost, these operations are executed in the Montgomery domain.

For a given operation, all needed computations are performed within the accelerator, so no further hardware or software elaboration is needed to process the inputs or the outputs.

When manipulating secrets, the PKA incorporates protection against side-channel attacks (SCA), including differential power analysis (DPA), certified SESIP, and PSA security assurance level 3.

The PKA main features are:

- Acceleration of RSA, DH, and ECC over GF(p) operations, based on the Montgomery method for fast modular multiplications. More specifically:
 - RSA modular exponentiation, RSA Chinese remainder theorem (CRT) exponentiation
 - ECC scalar multiplication, point on curve check, complete addition, double base ladder, projective to affine
 - ECDSA signature generation and verification
- Capability to handle operands up to 4160 bits for RSA/DH and 640 bits for ECC
- When manipulating secrets: protection against side-channel attacks (SCA), including differential power analysis (DPA), certified SESIP, and PSA security assurance level 3
 - Applicable to modular exponentiation, ECC scalar multiplication, and ECDSA signature generation
- Arithmetic and modular operations such as addition, subtraction, multiplication, modular reduction, modular inversion, comparison, and Montgomery multiplication
- Built-in Montgomery domain inward and outward transformations
- AMBA AHB slave peripheral, accessible through 32-bit word single accesses only (otherwise an AHB bus error is generated, and write accesses are ignored)
- Support for CCB chaining operations required to protect the private key used in PKA protected operations
- Hardware protections to monitor the usage of private keys during protected operation initialization

3.26 Timers and watchdogs

The devices include two advanced control timers, up to eleven general-purpose timers, two basic timers, two low-power timers, two watchdog timers, and one SysTick timer.

The table below compares the features of the advanced control, general-purpose and basic timers.

Table 7. Timer feature comparison

Timer type	Timer	Counter resolution	Counter type	Prescaler factor	DMA request generation	Capture / compare channels	Complementary outputs
Advanced control	TIM1, TIM8	16 bits	Up, down, Up/down	Any integer between 1 and 65536	Yes	4	4
General-purpose	TIM2, TIM5	32 bits	Up, down, Up/down	Any integer between 1 and 65536	Yes	4	No
	TIM12	16 bits	Up		No	2	No
	TIM15	16 bits	Up, down, Up/down		Yes	2	1
	TIM16, TIM17	16 bits	Up, down, Up/down		Yes	1	No
Basic	TIM6, TIM7	16 bits	Up	Any integer between 1 and 65536	Yes	0	No

3.26.1 Advanced-control timers (TIM1/TIM8)

The advanced-control timers (TIM1/TIM8) consist of a 16-bit autoreload counter driven by a programmable prescaler.

They may be used for various purposes, including measuring the pulse lengths of input signals (input capture) or generating output waveforms (output compare, PWM, complementary PWM with dead-time insertion).

Pulse lengths and waveform periods can be modulated from a few microseconds to several milliseconds using the timer prescaler and the RCC clock controller prescalers.

TIM1/TIM8 timer features include:

- 16-bit up, down, up/down autoreload counter
- 16-bit programmable prescaler allowing dividing (also “on the fly”) the counter clock frequency by any factor from 1 to 65536
- Seven independent channels for:
 - Input capture (except channels 5, 6, and 7)
 - Output compare
 - PWM generation (edge- and center-aligned mode)
 - One-pulse mode output
- Complementary outputs with programmable dead-time
- Synchronization circuit to control the timer with external signals and to interconnect several timers together
- Repetition counter to update the timer registers only after a given number of cycles of the counter
- Two break inputs to put the timer’s output signals in a safe user-selectable configuration
- Interrupt/DMA generation on the following events:
 - Update: counter overflow/underflow, counter initialization (by software or internal/external trigger)
 - Trigger event (counter start, stop, initialization, or count by internal/external trigger)
 - Input capture
 - Output compare
- Incremental encoders, quadrature encoders, and hall-sensors support
- Trigger input for external clock or cycle-by-cycle current management
- ADC synchronization for jitter-free sampling points

3.26.2

General-purpose timers (TIM2/TIM3/TIM4/TIM5/TIM12/TIM15/TIM16/TIM17)

The general-purpose timers (TIMx) consist of a 16-bit or 32-bit autoreload counter driven by a programmable prescaler.

They can be used for various purposes, including measuring the pulse lengths of input signals (input capture) or generating output waveforms (output compare and PWM).

Pulse lengths and waveform periods can be modulated from a few microseconds to several milliseconds using the timer prescaler and the RCC clock controller prescalers.

General-purpose TIMx timer features include:

- 16-bit or 32-bit up, down, up/down autoreload counter
- 16-bit programmable prescaler used to divide (also “on the fly”) the counter clock frequency by any factor between 1 and 65535
- Up to four independent channels for:
 - Input capture
 - Output compare
 - PWM generation (edge- and center-aligned modes)
 - One-pulse mode output
- Synchronization circuit to control the timer with external signals and to interconnect several timers
- Interrupt/DMA generation on the following events:
 - Update: counter overflow/underflow, counter initialization (by software or internal/external trigger)
 - Trigger event (counter start, stop, initialization, or count by internal/external trigger)
 - Input capture
 - Output compare
- Supports incremental (quadrature) encoder and hall-sensor circuitry for positioning purposes
- Trigger input for external clock or cycle-by-cycle current management
- ADC synchronization for jitter-free sampling points

3.26.3 Basic timers (TIM6/TIM7)

The basic timers (TIM6/TIM7) consist of a 16-bit autoreload counter driven by a programmable prescaler.

They can be used as generic timers for time-base generation.

The basic timer can also be used for triggering the digital-to-analog converter. This is done with the trigger output of the timer.

The timers are completely independent and do not share any resources.

Basic timer (TIM6/TIM7) features include:

- 16-bit autoreload upcounter
- 16-bit programmable prescaler used to divide (also “on the fly”) the counter clock frequency by any factor between 1 and 65535
- Synchronization circuit to trigger the DAC
- Interrupt/DMA generation on the update event: counter overflow
- ADC synchronization for jitter-free sampling points

3.26.4 Low-power timers (LPTIM1)

The LPTIM is a 16-bit timer that benefits from the ultimate developments in power consumption reduction. Thanks to its diversity of clock sources, the LPTIM can keep running in all power modes except for Standby mode. Given its capability to run even with no internal clock source, the LPTIM can be used as a pulse counter, which can be useful in some applications. The LPTIM capability to wake up the system from low-power modes makes it suitable to realize timeout functions with extremely low-power consumption.

The low-power timer supports the following features:

- 16-bit up counter with 16-bit auto reload register
- 3-bit prescaler with eight possible dividing factors (1, 2, 4, 8, 16, 32, 64, 128)
- Selectable clock
 - Internal clock sources: LSE, LSI, HSI, or APB clock
 - External clock source over LPTIM input (working with no LP oscillator running, used by pulse counter application)
- 16-bit ARR auto reload register
- 16-bit capture/compare register
- Continuous/one-shot mode
- Selectable software/hardware input trigger
- Programmable digital glitch filter
- Configurable output: pulse, PWM
- Configurable I/O polarity
- Encoder mode
- Repetition counter
- Up to two independent channels for:
 - Input capture
 - PWM generation (edge-aligned mode)
 - One-pulse mode output
- Interrupt generation on ten events
- DMA request generation on the following events:
 - Update event
 - Input capture

3.26.5 Independent watchdog (IWDG)

The independent watchdog (IWDG) peripheral offers a high safety level due to its capability to detect malfunctions caused by software or hardware failures.

The IWDG is clocked by an independent clock and remains active even if the main clock fails.

Additionally, the watchdog function is performed in the VDD voltage domain, allowing the IWDG to remain functional even in low-power modes.

The IWDG main features are:

- 12-bit down-counter
- Dual voltage domain, thus enabling operation in low-power modes
- Independent clock
- Early wake-up interrupt generation
- Reset generation:
 - In case of timeout
 - In case of refresh outside the expected window

3.26.6 Window watchdog (WWDG)

The system window watchdog (WWDG) is used to detect the occurrence of a software fault, usually generated by external interference or unforeseen logical conditions, which causes the application program to abandon its normal sequence.

The watchdog circuit generates a reset on the expiry of a programmed time period unless the program refreshes the contents of the down-counter before the T6 bit is cleared. A reset is also generated if the 7-bit down-counter value (in the control register) is refreshed before the down-counter reaches the window register value. This implies that the counter must be refreshed in a limited window.

The WWDG clock is prescaled from the APB clock and has a configurable time window that can be programmed to detect abnormally late or early application behavior.

The WWDG is best suited for applications requiring the watchdog to react within an accurate timing window.

The WWDG main features are:

- Programmable free-running down-counter
- Conditional reset:
 - Reset (if watchdog activated) when the down-counter value becomes lower than 0x40
 - Reset (if watchdog activated) if the down-counter is reloaded outside the window
- Early wake-up interrupt (EWI): triggered (if enabled and the watchdog activated) when the down-counter is equal to 0x40

3.26.7 SysTick timer

The Cortex[®]-M33 embeds one SysTick timer.

This timer is dedicated to real-time operating systems, but can also be used as a standard down counter. It features:

- A 24-bit down counter
- Auto reload capability
- Maskable system interrupt generation when the counter reaches 0
- Programmable clock source

3.27 Real-time clock (RTC), tamper and backup registers

3.27.1 Real-time clock (RTC)

The real-time clock (RTC) supports the following features:

- Calendar with subsecond, seconds, minutes, hours (12 or 24 format), weekday, date, month, year, in BCD (binary-coded decimal) format
- Binary mode with 32-bit free-running counter
- Automatic correction for 28, 29 (leap year), 30, and 31 days of the month
- Two programmable alarms
- On-the-fly correction from 1 to 32767 RTC clock pulses. This can be used to synchronize it with a controller clock.
- Reference clock detection: a more precise second source clock (50 or 60 Hz) can be used to enhance the calendar precision.
- Digital calibration circuit with 0.95 ppm resolution, to compensate for quartz crystal inaccuracy
- Timestamp feature that can be used to save the calendar content. This function can be triggered by an event on the timestamp pin, or by a tamper event.
- 17-bit auto-reload wake-up timer (WUT) for periodic events with programmable resolution and period
- Privilege protection support:
 - Alarm A, alarm B, wake-up timer, and timestamp individual privileged protection

The RTC is functional in all low-power modes when it is clocked by the LSE.

All RTC events (alarm, wake-up timer, timestamp) can generate an interrupt and wake up the device from the low-power modes.

3.27.2 Tamper and backup registers (TAMP)

The antitamper detection circuit is used to protect sensitive data from external attacks. Thirty-two 32-bit backup registers are retained in all low-power modes. The backup registers, as well as other secrets in the device, are protected by this antitamper detection circuit with three tamper pins and six internal tampers. The external tamper pins can be configured for edge detection or level detection with or without filtering.

The TAMP main features are:

- A tamper detection can optionally erase the backup registers, SRAM2, ICACHE, and cryptographic peripherals. The device resources protected by tamper are named “device secrets”.
- 32 × 32-bit backup registers
- Up to three tamper pins for three external tamper detection events:
 - Passive tampers: Ultralow-power edge or level detection with internal pull-up hardware management
 - Configurable digital filter
- Six internal tamper events to protect against transient attacks
- Each tamper can be configured in two modes:
 - Confirmed mode: immediate erase of secrets on tamper detection, including backup registers erase
 - Potential mode: most of the secrets erase following a tamper detection are launched by software
- Any tamper detection can generate an RTC timestamp event
- Tamper configuration and backup registers privilege protection

3.28 Inter-integrated circuit interface (I2C)

The device embeds two I2C interfaces. Refer to [Table 8](#) for feature implementation.

The I²C bus interface handles communications between the microcontroller and the serial I²C bus. It controls all I²C bus-specific sequencing, protocol, arbitration, and timing.

It supports Standard-mode (Sm), Fast-mode (Fm), and Fast-mode Plus (Fm+).

The I2C peripheral is also system management bus (SMBus) and power management bus (PMBus[®]) compatible. It can use DMA to reduce the CPU load.

The I²C peripheral supports:

- I²C-bus specification rev03 compatibility:
 - Controller and target modes
 - Multicontroller capability
 - Standard-mode (up to 100 kHz)
 - Fast-mode (up to 400 kHz)
 - Fast-mode Plus (up to 1 MHz)
 - 7-bit and 10-bit addressing mode
 - Multiple 7-bit target addresses (2 addresses, 1 with configurable mask)
 - All 7-bit addresses acknowledge mode
 - General call
 - Programmable setup and hold times
 - Easy-to-use event management
 - Clock stretching (optional)
- 1-byte buffer with DMA capability
- Programmable analog and digital noise filters
- SMBus specification rev 3.0 compatibility:
 - Hardware PEC (packet error checking) generation and verification with ACK control
 - Command and data acknowledge control
 - Address resolution protocol (ARP) support
 - Host and device support – SMBus alert
 - Timeouts and idle condition detection
- PMBus rev 1.3 standard compatibility
- Independent clock
- Wake-up from Stop mode on address match

Table 8. I2C implementation

Features ⁽¹⁾	I2C1	I2C2
Standard-mode (up to 100 Kbit/s)	X	X
Fast mode (up to 400 Kbit/s)	X	X
Fast mode plus (Fm+) with 20 mA output drive I/Os (up to 1 Mbit/s)	X	X
Programmable analog and digital noise filters	X	X
SMBus/PMBus hardware support	X	X
Independent clock	X	X
Wake-up capability	X	X

1. X = supported.

3.29 Improved inter-integrated circuit interface (I3C)

The I3C interface handles communication between this device and others, such as sensors and the host processor, connected on an I3C bus.

An I3C bus is a two-wire, serial single-ended, multidrop bus, intended to improve a legacy I²C bus.

The I3C SDR-only peripheral implements all the features required by the MIPI[®] I3C specification v1.1. It can control all I3C bus-specific sequencing, protocol, arbitration, and timing, and can act as a controller (formerly known as master) or as a target (formerly known as slave). When acting as a controller, the I3C peripheral improves the features of the I2C interface while preserving some backward compatibility: it allows an I²C target to operate on an I3C bus in legacy I²C fast mode (Fm) or legacy I²C fast mode plus (Fm+), provided that the latter does not perform clock stretching. The I3C peripheral can be used with DMA to offload the CPU.

The I3C peripheral supports:

- MIPI® I3C specification v1.1, as:
 - I3C SDR-only primary controller
 - I3C SDR-only secondary controller
 - I3C SDR-only target
- I3C SCL bus clock frequency up to 12.5 MHz
- Registers configuration from the host application via the APB target port
- Queued data transfers:
 - Transmit FIFO (TX-FIFO) for data bytes/words to be transmitted on the I3C bus
 - Receive FIFO (RX-FIFO) for received data bytes/words on the I3C bus
 - For each FIFO, optional DMA mode with a dedicated DMA channel
- Queued control/status transfers, when controller:
 - Control FIFO (C-FIFO) for control words to be sent on the I3C bus
 - Optional status FIFO (S-FIFO) for status words as received on the I3C bus
 - For each FIFO, optional DMA mode with a dedicated DMA channel
- Messages:
 - Legacy I²C read/write messages to legacy I²C targets in Fm/Fm+
 - I3C SDR read/write private messages
 - I3C SDR broadcast CCC messages
 - I3C SDR read/write direct CCC messages
- Frame-level management, when controller:
 - Optional C-FIFO and TX-FIFO preload
 - Multiple messages encapsulation
 - Optional arbitrable header generation on the I3C bus
 - HDR exit pattern generation on the I3C bus for error recovery
- Programmable bus timing, when controller:
 - SCL high and low period
 - SDA hold time
 - Bus free (minimum) time
 - Bus available/idle condition time
 - Clock stall time
- Target-initiated requests management:
 - Simultaneous support up to four targets, when controller
 - In-band interrupts, with programmable IBI payload (up to four bytes), with pending read notification support
 - Bus control request, with recovery flow support and hand-off delay
 - Hot-join mechanism
- HDR exit pattern detection, when target
- Bus error management:
 - CEx with x = 0, 1, 2, 3 when controller
 - TEx with x = 0, 1, ... , 6 when target
 - Bus control switch error and recovery
 - Target reset
- Individual programmable event-based management:
 - Per-event identification with flag reporting and clear control
 - Host application notification via flag polling, and/or via interrupt with a per-event programmable enable
 - Error type identification

- Wake-up from Stop mode(s), as controller:
 - On an in-band interrupt without payload
 - On a hot-join request
 - On a controller-role request
- Wake-up from Stop mode(s), as target:
 - On a reset pattern
 - On a missed start
- Multiclock domain management:
 - Separate APB clock and kernel clock, driven from independently programmed clock sources via the RCC, in addition to SCL clock
 - Minimum operating frequency for the kernel clock and the APB clock vs. the application-driven SCL clock

Table 9. I3C peripheral controller/target features versus MIPI® v1.1

Features ⁽¹⁾	MIPI® I3C v1.1	I3C peripheral when controller	I3C peripheral when target	Comments
I3CSDR message	X	X	X	-
Legacy I ² C message (Fm/Fm+)	X	X	-	Mandatory when controller and the I3C bus is mixed with (external) legacy I ² C target(s). Optional in MIPI v1.1 when target.
HDR DDR message	X	-	-	Optional in MIPI v1.1
HDR-TSL/TSP, HDR-BT	X	-	-	
Dynamic address assignment	X	X	X	-
Static address	X	X	-	No (intended) support of I3C peripheral as a target on an I ² C bus.
Grouped addressing	X	X	-	Optional in MIPI v1.1
CCCs	X	X	X	Mandatory CCCs and some optional CCCs are supported.
Error detection and recovery	X	X	X	-
In-band interrupt (with MDB)	X	X	X	-
Secondary controller	X	X	X	-
Hot-join mechanism	X	X	X	-
Target reset	X	X	X	-
Synchronous timing control	X	X	-	Optional in MIPI v1.1
Asynchronous timing control 0	X	X	-	
Asynchronous timing control 1, 2, 3	X	-	-	
Device-to-device tunneling	X	X	-	
Multilane data transfer	X	X	-	
Monitoring device early termination	X	-	-	

1. X = supported.

3.30 Universal synchronous/asynchronous receiver transmitter (USART/UART) and low-power universal asynchronous receiver transmitter (LPUART)

The devices have four embedded universal synchronous receiver transmitters (USART1/2/3/6), three universal asynchronous receiver transmitters (UART4/5/7), and one low-power universal asynchronous receiver transmitter (LPUART1).

Table 10. USART, UART, and LPUART features

Features ⁽¹⁾	USART1/2/3/6	UART4/5/7	LPUART1
Hardware flow control for modem	X	X	X
Continuous communication using DMA	X	X	X
Multiprocessor communication	X	X	X
Synchronous mode (controller/target)	X	-	-
Smartcard mode	X	-	-
Single-wire half-duplex communication	X	X	X
IrDA SIR ENDEC block	X	X	-
LIN mode	X	X	-
Dual-clock domain and wake-up from Stop mode	X ⁽²⁾	X ⁽²⁾	X ⁽²⁾
Receiver timeout interrupt	X	X	X
Modbus communication	X	X	X
Autobaud rate detection	X	X	X
Driver enable	X	X	X
USART data length	7, 8, and 9 bits		
Tx/Rx FIFO	X	X	X
Tx/Rx FIFO size	8 bytes		

1. X = supported.

2. Wake-up supported from Stop mode.

3.30.1 Universal synchronous/asynchronous receiver transmitter (USART/UART)

The USART offers a flexible means to perform full-duplex data exchange with external equipment requiring an industry standard NRZ asynchronous serial data format. A very wide range of baud rates can be achieved through a fractional baud rate generator.

The USART supports both synchronous one-way and half-duplex single-wire communications, as well as LIN (local interconnection network), Smartcard protocol, IrDA (infrared data association) SIR ENDEC specifications, and modem operations (CTS/RTS). Multiprocessor communications are also supported.

High-speed data communications are possible by using the DMA (direct memory access) for multibuffer configuration.

The USART main features are:

- Full-duplex asynchronous communication
- NRZ standard format (mark/space)
- Configurable oversampling method by 16 or 8 to achieve the best compromise between speed and clock tolerance
- Baud rate generator systems
- Two internal FIFOs for transmit and receive data
- Each FIFO can be enabled/disabled by software and come with a status flag.
- A common programmable transmit and receive baud rate
- Dual-clock domain with dedicated kernel clock for peripherals independent from PCLK
- Auto baud rate detection
- Programmable data word length (7, 8, or 9 bits)
- Programmable data order with MSB-first or LSB-first shifting
- Configurable stop bits (one or two stop bits)
- Synchronous controller/target mode and clock output/input for synchronous communications
- SPI controller transmission underrun error flag
- Single-wire half-duplex communications
- Continuous communications using DMA
- Received/transmitted bytes are buffered in reserved SRAM using centralized DMA
- Separate enable bits for transmitter and receiver
- Separate signal polarity control for transmission and reception
- Swappable Tx/Rx pin configuration
- Hardware flow control for modem and RS-485 transceiver
- Communication control/error detection flags
- Parity control:
 - Transmits parity bit
 - Checks parity of received data byte
- Interrupt sources with flags
- Multiprocessor communications: wake-up from Mute mode by idle line detection or address mark detection
- Wake-up from Stop capability
- LIN controller synchronous break send capability and LIN target break detection capability
 - 13-bit break generation and 10/11-bit break detection when USART is hardware configured for LIN
- IrDA SIR encoder decoder supporting 3/16-bit duration for Normal mode
- Smartcard mode
 - Supports the T = 0 and T = 1 asynchronous protocols for smartcards as defined in the ISO/IEC 7816-3 standard
 - 0.5 and 1.5 stop bits for Smartcard operation
- Support for Modbus communication
 - Timeout feature
 - CR/LF character recognition

3.30.2 Low-power universal asynchronous receiver transmitter (LPUART)

The LPUART is a UART, which enables bidirectional UART communications with a limited power consumption. Only a 32.768 kHz LSE clock is required to enable UART communications up to 9600 bauds. Higher baud rates can be reached when the LPUART is clocked by clock sources different from the LSE clock.

Even when the microcontroller is in low-power mode, the LPUART can wait for an incoming UART frame while having an extremely low energy consumption. The LPUART includes all necessary hardware support to make asynchronous serial communications possible with minimum power consumption.

It supports half-duplex single-wire communications and modem operations (CTS/RTS).

It also supports multiprocessor communications. The direct memory access (DMA) can be used for data transmission/reception.

The LPUART main features are:

- Full-duplex asynchronous communications
- NRZ standard format (mark/space)
- Programmable baud rate
- From 300 bauds to 9600 bauds using a 32.768 kHz clock source
- Higher baud rates can be achieved by using a higher frequency clock source
- Two internal FIFOs to transmit and receive data
Each FIFO can be enabled/disabled by software and come with status flags for FIFOs states.
- Dual-clock domain with dedicated kernel clock for peripherals independent from PCLK
- Programmable data word length (7 or 8 or 9 bits)
- Programmable data order with MSB-first or LSB-first shifting
- Configurable stop bits (one or two stop bits)
- Single-wire half-duplex communications
- Continuous communications using DMA
- Received/transmitted bytes are buffered in reserved SRAM using centralized DMA
- Separate enable bits for transmitter and receiver
- Separate signal polarity control for transmission and reception
- Swappable Tx/Rx pin configuration
- Hardware flow control for modem and RS-485 transceiver
- Transfer detection flags:
 - Receive buffer full
 - Transmit buffer empty
 - Busy and end of transmission flags
- Parity control:
 - Transmits parity bit
 - Checks parity of received data byte
- Four error detection flags:
 - Overrun error
 - Noise detection
 - Frame error
 - Parity error
- Interrupt sources with flags
- Multiprocessor communications: wake-up from Mute mode by idle line detection or address mark detection
- Wake-up from Stop mode

3.31 Serial peripheral interface (SPI)/Inter-integrated sound interfaces (I2S)

The devices embed three serial peripheral interfaces (SPI) that can be used to communicate with external devices while using the specific synchronous protocol. The SPI protocol supports half-duplex, full-duplex, and simplex synchronous, serial communication with external devices.

Table 11. SPI features

SPI feature	SPI2S1, SPI2S2, SPI2S3 (full feature set instances)
Data size	Configurable from 4 to 32-bit
CRC computation	CRC polynomial length configurable from 5 to 32-bit
Size of FIFOs	16 × 8-bit
Number of transferred data	Unlimited, expandable
I2S feature	Yes

The serial peripheral interface (SPI) can be used to communicate with external devices while using the specific synchronous protocol. The SPI protocol supports half-duplex, full-duplex, and simplex synchronous, serial communication with external devices. The interface can be configured as master or slave and can operate in multimaster or multislave configurations. The device configured as master provides a communication clock (SCK) to the slave device. The slave select (SS) and ready (RDY) signals can be applied optionally just to set up communication with a specific slave and to ensure it handles the data flow properly. The Motorola® data format is used by default, but some other specific modes are supported as well.

The SPI main features are:

- Full-duplex synchronous transfers on three lines
- Half-duplex synchronous transfer on two lines (with bidirectional data line)
- Simplex synchronous transfers on two lines (with unidirectional data line)
- From 4-bit up to 32-bit data size selection
- Multimaster or multislave mode capability
- Dual clock domain, the peripheral kernel clock is independent from the APB bus clock
- Baud rate prescaler up to kernel frequency/2 or bypass from RCC in master mode
- Protection of configuration and setting
- Hardware or software management of SS for both master and slave
- Adjustable minimum delays between data and between SS and data flow
- Configurable SS signal polarity and timing, MISO × MOSI swap capability
- Programmable clock polarity and phase
- Programmable data order with MSB-first or LSB-first shifting
- Programmable number of data within a transaction to control SS and CRC
- Dedicated transmission and reception flags with interrupt capability
- SPI Motorola and TI format support
- Hardware CRC can verify the integrity of the communication at the end of a transaction by:
 - Adding CRC value in Tx mode
 - Automatic CRC error checking for Rx mode
- Error detection with interrupt capability in case of data overrun, CRC error, data underrun, mode fault, and frame error, depending on the operating mode
- Two 8-bit width embedded Rx and Tx FIFOs (FIFO size depends on instance)
- Configurable FIFO thresholds (data packing)
- Capability to handle data streams by system DMA controller
- Configurable behavior at slave underrun condition (support of cascaded circular buffers)
- Optional status pin RDY signaling that the slave device is ready to handle the data flow

The I2S main features are:

- Full duplex communication
- Simplex communication (only transmitter or receiver)
- Master or slave operations
- 8-bit programmable linear prescaler
- Data length can be 16, 24, or 32 bits
- Channel length can be 16 or 32 in master, any value in slave
- Programmable clock polarity
- Error flags signaling for improved reliability: Underrun, overrun, and frame errors
- Embedded Rx and Tx FIFOs
- Supported I2S protocols:
 - I2S Philips standard
 - MSB-justified standard (left-justified)
 - LSB-justified standard (right-justified)
 - PCM standard (with short and long frame synchronization)
- Data ordering programmable (LSB or MSB first)
- DMA capability for transmission and reception
- Master clock can be output to drive an external audio component:
 - FMCK = $256 \times \text{FWS}$ for all I2S modes
 - FMCK = $128 \times \text{FWS}$ for all PCM modes

3.32 Controller area network (FDCAN)

The controller area network (CAN) subsystem consists of one CAN module, a shared message RAM memory, and a configuration block.

The modules (FDCAN) are compliant with ISO 11898-1: 2015 (CAN protocol specification version 2.0 part A, B) and CAN FD protocol specification version 1.0.

A 0.8-Kbyte message RAM implements filters, receives FIFOs, transmits event FIFOs, and transmits FIFOs.

The FDCAN main features are:

- Conform with CAN protocol version 2.0 part A, B, and ISO 11898-1: 2015, -4
- CAN FD with maximum 64 data bytes supported
- CAN error logging
- AUTOSAR and J1939 support
- Improved acceptance filtering
- Two receive FIFOs of three payloads each (up to 64 bytes per payload)
- Separate signaling on reception of high priority messages
- Configurable transmit FIFO/queue of three payloads (up to 64 bytes per payload)
- Configurable transmit event FIFO
- Programmable loop-back test mode
- Maskable module interrupts
- Two clock domains: APB bus interface and CAN core kernel clock
- Power-down support

3.33 Universal serial bus full-speed host/device interface (USB)

The USB peripheral implements an interface between a full-speed USB 2.0 bus and the APB2 bus. USB suspend and resume are supported, which permits stopping the device clocks for low-power consumption.

The USB main features are:

- USB specification version 2.0 full-speed compliant
- Supports both host and device modes
- Configurable number of endpoints from 1 to 8
- Dedicated packet buffer memory (SRAM) of 2048 bytes
- Cyclic redundancy check (CRC) generation/checking, non-return-to-zero inverted (NRZI) encoding/decoding, and bit-stuffing
- Isochronous transfers support
- Double-buffered bulk/isochronous endpoint/channel support
- USB suspend and resume operations
- Frame-locked clock pulse generation
- USB 2.0 link power management support (device mode only)
- Battery charging specification revision 1.2 support (device mode only)
- USB connect/disconnect capability (controllable embedded pull-up resistor on USB_DP line)

3.34 Ethernet (ETH): media access control (MAC) with DMA controller

The Ethernet peripheral enables the transmission and reception of data over Ethernet in compliance with the IEEE 802.3-2015 standard. The peripheral is configurable to meet the needs of a large variety of consumer and industrial applications.

The Ethernet peripheral embeds a dedicated DMA for direct memory interface, a media access controller (MAC), and a PHY interface block supporting several formats.

The Ethernet peripheral is compliant with the following standards:

- IEEE 802.3-2015 for Ethernet MAC and media independent interface (MII)
- IEEE 1588-2008 for precision networked clock synchronization (PTP)
- IEEE 802.3az-2010 for Energy Efficient Ethernet (EEE)
- AMBA 2.0 for AHB master and AHB slave ports
- RMI specification version 1.2 from RMI consortium
- OPEN Alliance 10BASE-T1S PMD Transceiver Interface version 1.5
- IEEE Std 802.3cg™

The MAC Tx and Rx common features are:

- Separate transmission, reception, and control interfaces to the application
- 10, 100 Mbps data transfer rates with the following PHY interfaces:
 - IEEE 802.3-compliant MII interface to communicate with an external Fast Ethernet PHY
 - RMII interface to communicate with an external Fast Ethernet PHY
 - OPEN Alliance-compliant 10BASE-T1S PMD Transceiver Interface draft 1.5 to communicate with an external 10BASE-T1S PMD transceiver
- 10BASE-T1S features support the following operating modes:
 - Half-duplex as well as full-duplex PHY with a single link partner over a point-to-point link segment
 - Half-duplex shared-medium mode, referred to as multidrop mode, to operate with multiple stations connected to a mixing segment (PLCA)
- Half-duplex operation:
 - CSMA/CD protocol support
 - Flow control using backpressure (based on implementation-specific white papers and UNH Ethernet Clause 4 MAC Test Suite - Annex D)
- Standard IEEE 802.3az-2010 for Energy Efficient Ethernet in MII PHYs
- 32-bit data transfer interface on the application side
- Full-duplex flow control operations (IEEE 802.3x Pause packets and Priority flow control)
- Network statistics with RMON or MIB counters (partial support of RFC2819/RFC2665)
- Ethernet packet timestamping as described in IEEE 1588-2002 and IEEE 1588-2008 (64-bit timestamps given in the Tx or Rx status of PTP packet). Both one-step and two-step timestamping are supported in Tx direction.
- Flexibility to control pulse-per-second (PPS) output signal (eth_ptp_pps_out and ETH_PPS_OUT)
- MDIO (Clause 22 and Clause 45) master interface for PHY device configuration and management

The MAC Tx features are:

- Preamble and start-of-frame data (SFD) insertion
- Separate 32-bit status for each packet transmitted from the application
- Automatic CRC and pad generation controllable on a per-frame basis
- Programmable packet length to support Standard or Jumbo Ethernet packets of up to 16 Kbytes
- Programmable Inter Packet Gap (40-96 bit times in steps of 8)
- IEEE 802.3x Flow Control automatic transmission of zero-quanta Pause packet when flow control input transitions from assertion to de-assertion (in Full-duplex mode)
- Source address field insertion or replacement, and VLAN insertion, replacement, and deletion in transmitted packets with per-packet or static-global control
- Insertion, replacement, or deletion of up to two VLAN tags
- Option to transmit packets with reduced preamble size in Full-duplex mode
- Insert, replace, or delete queue/channel-based VLAN tags

The MAC Rx features are:

- Automatic Pad and CRC stripping options
- Option to disable automatic CRC checking
- Preamble and SFD deletion
- Separate 112-bit or 128-bit status
- Programmable watchdog timeout limit
- Flexible address filtering modes:
 - Four 48-bit perfect (DA) address filters with masks for each byte
 - Four 48-bit SA address comparison check with masks for each byte
 - 64-bit Hash filter for multicast and unicast (DA) addresses
- Option to pass all multicast addressed packets
- Promiscuous mode to pass all packets without any filtering for network monitoring
- Pass all incoming packets (as per filter) with a status report
- Additional packet filtering:
 - VLAN tag-based: Perfect match and Hash-based filtering based either on the outer or inner VLAN tag
 - Layer 3 and Layer 4-based: TCP or UDP over IPv4 or IPv6
- IEEE 802.1Q VLAN tag detection and option to delete the VLAN tags in received packets
- Detection of remote wake-up packets and AMD magic packets
- Optional forwarding of received Pause packets to the application (in full-duplex mode)
- Layer 3/Layer 4 checksum offload for received packets
- Stripping of up to two VLAN tags and providing the tags in the status

3.35 Development support

3.35.1 Serial-wire/JTAG debug port (SWJ-DP)

The Arm® SWJ-DP interface is embedded and is a combined JTAG and serial-wire debug port that enables either a serial wire debug or a JTAG probe to be connected to the target.

Debug is performed using two pins only instead of five required by the JTAG (JTAG pins can be reused as GPIO with alternate function): the JTAG TMS and TCK pins are shared with SWDIO and SWCLK, respectively, and a specific sequence on the TMS pin is used to switch between JTAG-DP and SW-DP.

3.35.2 Embedded Trace Macrocell™

The Arm® Embedded Trace Macrocell™ (ETM) provides a greater visibility of the instruction and data flow inside the CPU core by streaming compressed data at a very high rate from the devices through a small number of ETM pins to an external hardware trace port analyzer (TPA) device.

Real-time instruction and data flow activity be recorded and then formatted for display on the host computer that runs the debugger software. TPA hardware is commercially available from common development tool vendors.

The ETM operates with third party debugger software tools.

4 Pinouts/ballouts, pin description, and alternate functions

4.1 Pinout/ballout schematics

Figure 3. LQFP32 pinout

Package top view

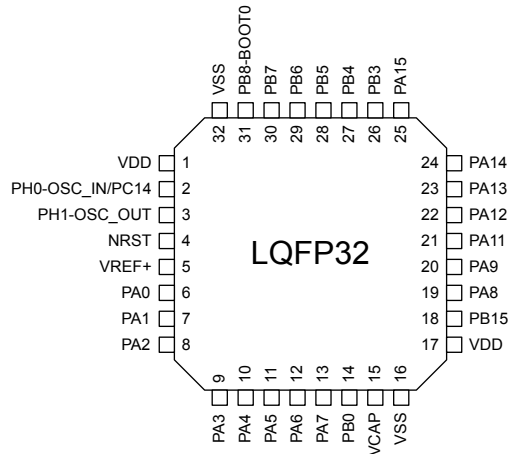

DT174257V2

Figure 4. UFQFPN32 pinout

Package top view

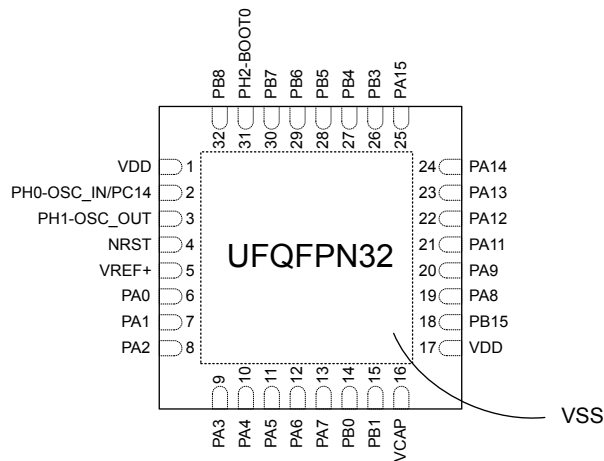

DT174256V2

Note: There is an exposed die pad on the underside of the UFQFPN package. This backside pad must be connected and soldered to PCB ground.

Figure 5. LQFP48 pinout

Package top view

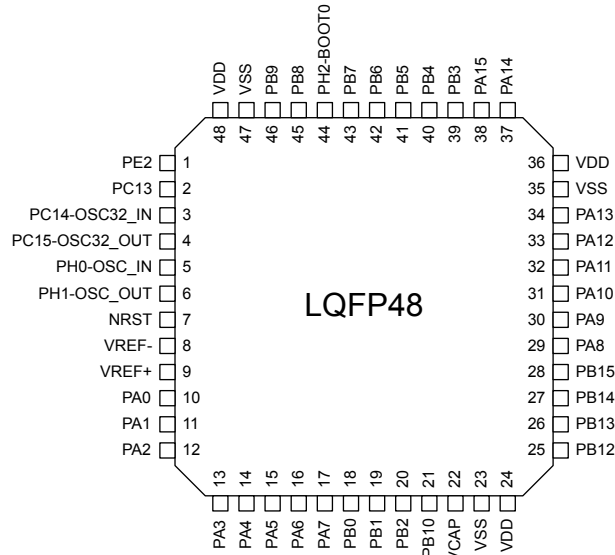

DT74258V1

Figure 6. UFQFPN48 pinout

Package top view

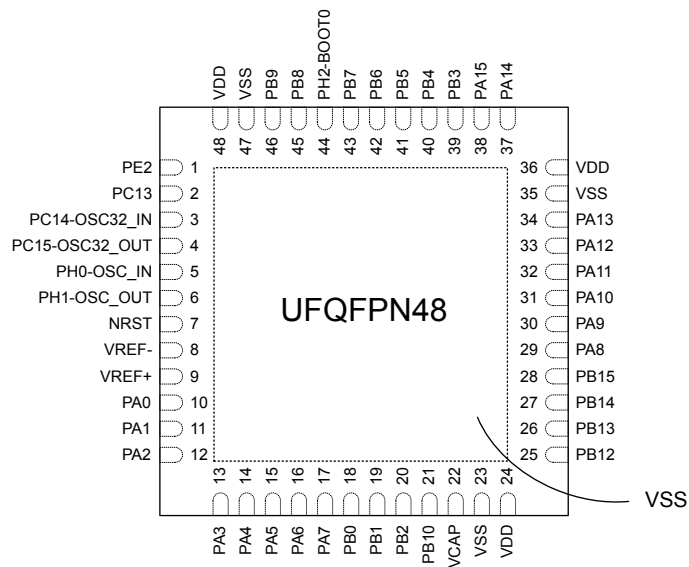

DT74259V1

Note: There is an exposed die pad on the underside of the UFQFPN package. This backside pad must be connected and soldered to PCB ground.

Figure 7. LQFP64 pinout

Package top view

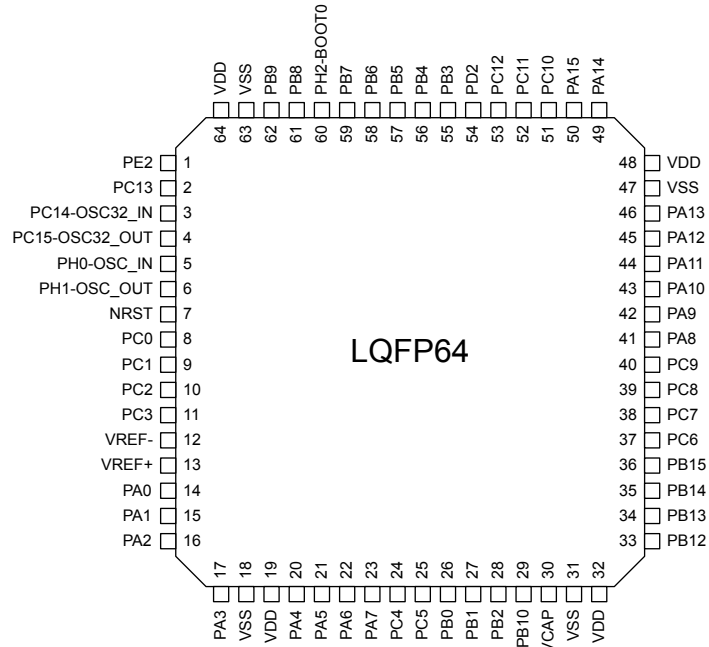

DT74260V1

Figure 8. LQFP80 pinout

Package top view

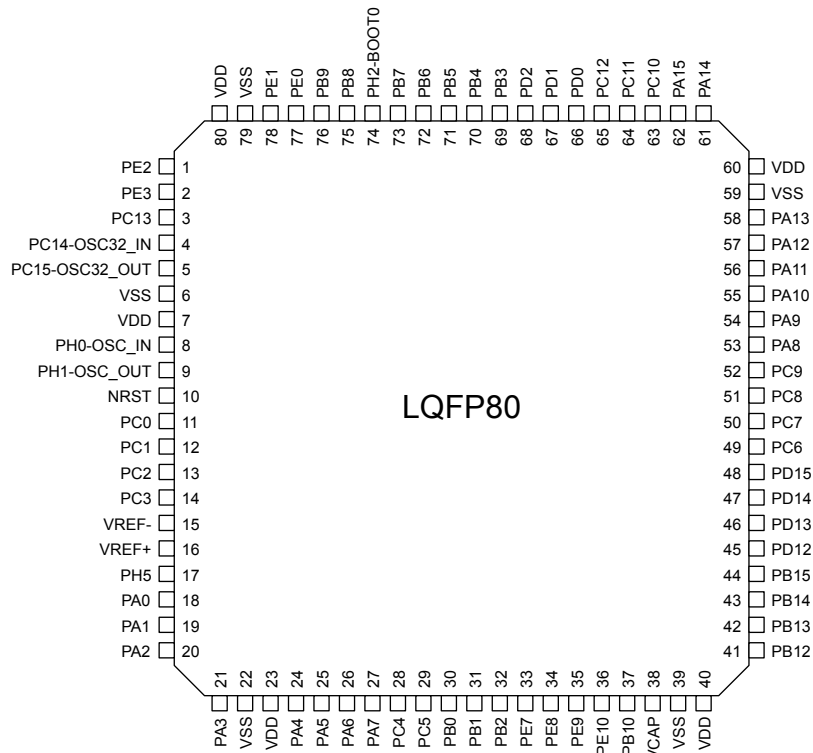

DT74261V1

Figure 9. LQFP100 pinout

Package top view

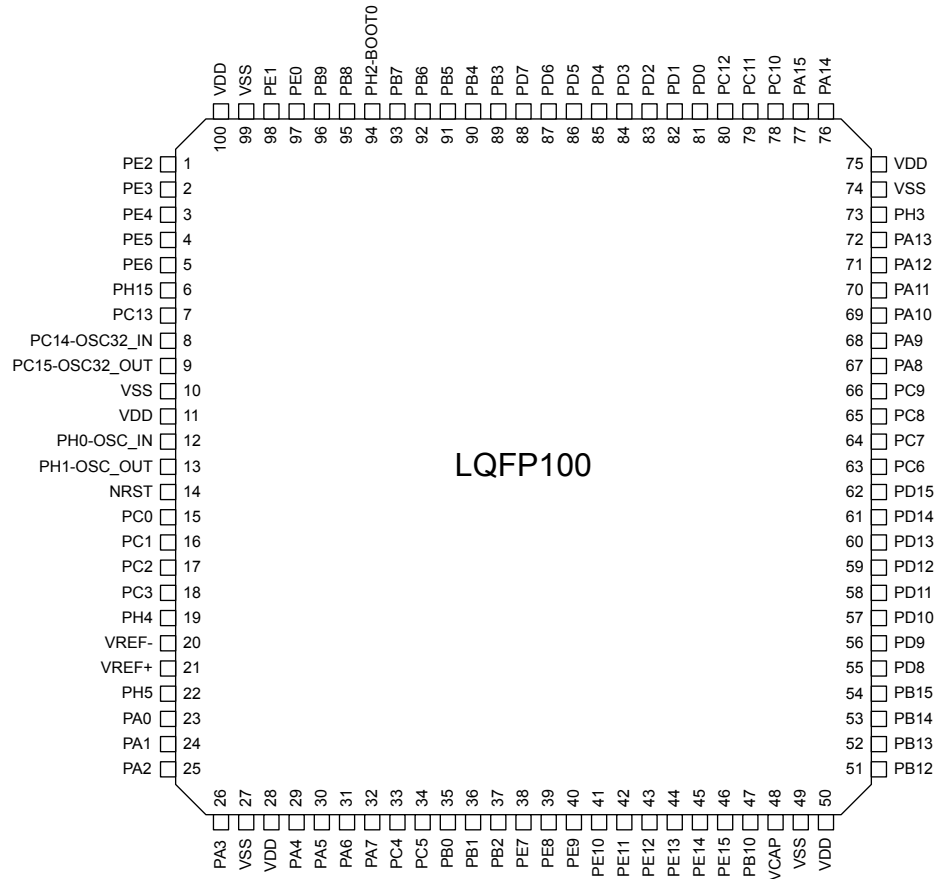

DT74262V1

Figure 10. LQFP144 pinout

Package top view

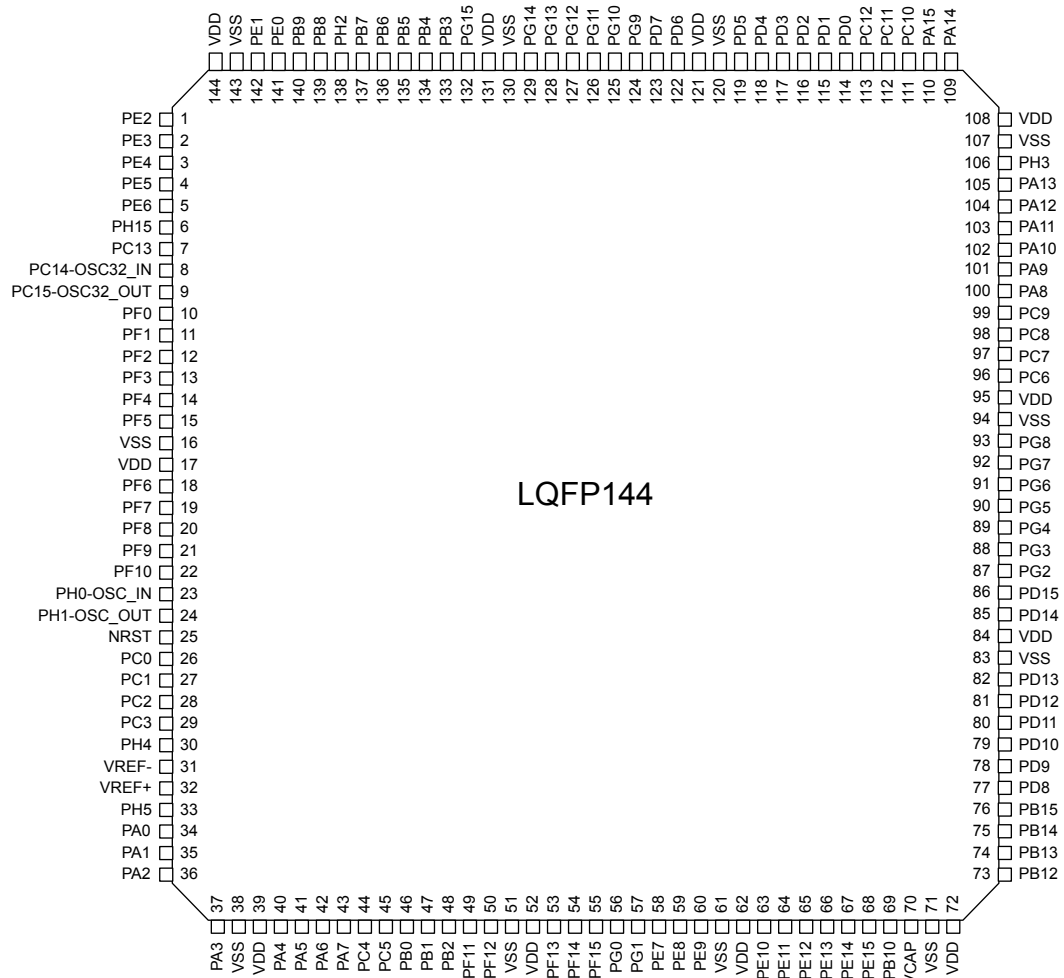

4.2 Pin description

Table 12. Legend/abbreviations used in the pinout table

Name	Abbreviation	Definition
Pin name	Unless otherwise specified in brackets below the pin name, the pin function during and after reset is the same as the actual pin name.	
Pin type	I	Input-only pin
	I/O	Input/output pin
	S	Supply pin
I/O structure	FT	5 V-tolerant I/O
	TT	3.6 V-tolerant I/O
	RST	Bidirectional reset pin with embedded weak pull-up resistor
	Options for TT and FT I/Os⁽¹⁾	
	_a	I/O with analog switch function supplied by V _{DDA}
	_t	Tamper I/O
	_f	I/O fm+ capable
	_u	I/O with USB function
Notes	Unless otherwise specified by a note, all I/Os are set as floating inputs during and after reset.	
Pin functions	Alternate functions	Functions selected through GPIOx_AFR registers
	Additional functions	Functions directly selected/enabled through peripheral registers

1. The related I/O structures in the table below are a concatenation of various options. Examples: FT, TT_a.



Table 13. STM32C5A3xxx pin/ball definition

Pin Number									Pin name (function after reset)	Pin type	I/O structure	Notes	Alternate functions	Additional functions
UFQFPN32	LQFP32	LQFP48	UFQFPN48	LQFP64	VFQFPN68	LQFP80	LQFP100	LQFP144						
-	-	1	1	1	1	1	1	1	PE2	I/O	FT	-	TRACECLK, LPTIM1_IN2, SPI3_SCK/I2S3_CK, XSPI1_IO2, ETH1_MII_TXD3, EVENTOUT	
-	-	-	-	-	-	2	2	2	PE3	I/O	FT	-	TRACED0, TIM15_BKIN, USART1_RX, EVENTOUT	
-	-	-	-	-	-	-	3	3	PE4	I/O	FT	-	TRACED1, TIM15_CH1N, SPI3_NSS/I2S3_WS, USART1_TX, ETH1_MII_RXD0/ETH1_RMII_RXD0, EVENTOUT	
-	-	-	-	-	-	-	4	4	PE5	I/O	FT	-	TRACED2, TIM15_CH1, SPI3_MISO/I2S3_SDI, USART1_CK, ETH1_MII_RXD1/ETH1_RMII_RXD1, EVENTOUT	
-	-	-	-	-	-	-	5	5	PE6	I/O	FT	-	TRACED3, TIM1_BKIN2, TIM15_CH2, SPI3_MOSI/I2S3_SDO, USART1_CTS/USART1_NSS, EVENTOUT	WKUP3
-	-	-	-	-	-	-	6	6	PH15	I/O	FT	-	USART1_RTS, EVENTOUT	
-	-	2	2	2	2	3	7	7	PC13	I/O	FT_t	(1)(2)	FDCAN1_TX, EVENTOUT	TAMP_IN1, RTC_OUT1/RTC_TS, WKUP4
2	2	3	3	3	3	4	8	8	PC14-OSC32_IN(OSC32_IN)	I/O	FT	(1)	TIM12_CH1, FDCAN1_RX, EVENTOUT	OSC32_IN
-	-	4	4	4	4	5	9	9	PC15-OSC32_OUT(OSC32_OUT)	I/O	FT	(1)	TIM12_CH2, EVENTOUT	OSC32_OUT
-	-	-	-	-	-	-	-	10	PF0	I/O	FT_f	-	I2C2_SDA, EVENTOUT	-
-	-	-	-	-	-	-	-	11	PF1	I/O	FT_f	-	I2C2_SCL, EVENTOUT	-
-	-	-	-	-	-	-	-	12	PF2	I/O	FT	-	I2C2_SMBA, EVENTOUT	-
-	-	-	-	-	-	-	-	13	PF3	I/O	FT	-	EVENTOUT	-
-	-	-	-	-	-	-	-	14	PF4	I/O	FT	-	EVENTOUT	-
-	-	-	-	-	-	-	-	15	PF5	I/O	FT_f	-	I3C1_SCL, EVENTOUT	-
-	-	-	-	-	-	6	10	16	VSS	S		-		-



Pin Number									Pin name (function after reset)	Pin type	I/O structure	Notes	Alternate functions	Additional functions
UFQFPN32	LQFP32	LQFP48	UFQFPN48	LQFP64	VFQFPN68	LQFP80	LQFP100	LQFP144						
-	-	-	-	-	-	7	11	17	VDD	S		-		-
-	-	-	-	-	-	-	-	18	PF6	I/O	FT	-	UART7_RX, TIM16_CH1, XSPI1_IO3, EVENTOUT	-
-	-	-	-	-	-	-	-	19	PF7	I/O	FT	-	TIM17_CH1, UART7_TX, XSPI1_IO2, EVENTOUT	-
-	-	-	-	-	-	-	-	20	PF8	I/O	FT	-	UART7_RTS, TIM16_CH1N, XSPI1_IO1, ETH1_MII_TX_ER, EVENTOUT	-
-	-	-	-	-	-	-	-	21	PF9	I/O	FT	-	TIM17_CH1N, UART7_CTS, ETH1_MDC, XSPI1_IO0, EVENTOUT	-
-	-	-	-	-	-	-	-	22	PF10	I/O	FT	-	XSPI1_CLK, TIM16_BKIN, EVENTOUT	-
2	2	5	5	5	5	8	12	23	PH0-OSC_IN(PH0)	I/O	FT_f	-	I2C1_SDA, EVENTOUT	OSC_IN
3	3	6	6	6	6	9	13	24	PH1-OSC_OUT(PH1)	I/O	FT_f	-	I2C1_SCL, EVENTOUT	OSC_OUT
4	4	7	7	7	7	10	14	25	NRST	I/O	RST	-	-	-
-	-	-	-	8	8	11	15	26	PC0	I/O	FT_a	-	SPI2_RDY, TIM16_BKIN, XSPI1_IO7, EVENTOUT	ADC1_IN8
-	-	-	-	9	9	12	16	27	PC1	I/O	FT_a	-	TRACED0, SPI2_MOSI/ I2S2_SDO, XSPI1_IO4, ETH1_MDC, XSPI1_IO6, EVENTOUT	ADC1_IN9, ADC2_IN9, TAMP_IN2, WKUP6
-	-	-	-	10	10	13	17	28	PC2	I/O	FT_a	-	PWR_CSLEEP, TIM17_CH1, TIM4_CH4, SPI2_MISO/ I2S2_SDI, XSPI1_IO2, ETH1_MII_TXD2, XSPI1_IO5, EVENTOUT	ADC1_IN10, ADC2_IN10
-	-	-	-	11	11	14	18	29	PC3	I/O	FT_a	-	PWR_CSTOP, LPUART1_TX, SPI2_MOSI/I2S2_SDO, XSPI1_IO6, XSPI1_IO0, ETH1_MII_TX_CLK, XSPI1_IO4, EVENTOUT	ADC1_IN11, ADC2_IN11
-	-	-	-	-	-	-	19	30	PH4	I/O	FT_a	-	EVENTOUT	ADC2_IN12, ADC3_IN12
-	-	8	8	12	12	15	20	31	VREF-	S		-	-	-



Pin Number									Pin name (function after reset)	Pin type	I/O structure	Notes	Alternate functions	Additional functions
UFQFPN32	LQFP32	LQFP48	UFQFPN48	LQFP64	VFQFPN68	LQFP80	LQFP100	LQFP144						
5	5	9	9	13	13	16	21	32	VREF+	S	-	-	-	
-	-	-	-	-	-	17	22	33	PH5	I/O	FT_a	-	EVENTOUT	ADC2_IN13, ADC3_IN13
6	6	10	10	14	14	18	23	34	PA0	I/O	FT_a	-	TIM2_CH1, TIM5_CH1, TIM8_ETR, TIM15_BKIN, SPI2_RDY, SPI3_RDY, USART2_CTS/USART2_NSS, UART4_TX, SPI2_NSS/ I2S2_WS, ETH1_MII_CRD, XSPI1_IO3, TIM2_ETR, EVENTOUT	ADC1_IN0, ADC2_IN0, COMP1_INP1, TAMP_IN2, WKUP1
7	7	11	11	15	15	19	24	35	PA1	I/O	FT_a	-	TIM2_CH2, TIM5_CH2, TIM8_BKIN, TIM15_CH1N, LPTIM1_IN1, USART2_RTS, UART4_RX, XSPI1_IO3, ETH1_MII_RX_CLK/ ETH1_RMII_REF_CLK, XSPI1_DQS, EVENTOUT	ADC1_IN1, ADC2_IN1, TAMP_IN3
8	8	12	12	16	16	20	25	36	PA2	I/O	FT_a	-	TIM2_CH3, TIM5_CH3, LPUART1_RX, TIM15_CH1, LPTIM1_IN2, USART2_TX, ETH1_MDIO, XSPI1_NCLK, EVENTOUT	ADC1_IN2, ADC2_IN2, TAMP_IN3, WKUP2
9	9	13	13	17	17	21	26	37	PA3	I/O	FT_a	-	TIM2_CH4, TIM3_CH3, LPUART1_TX, TIM15_CH2, SPI2_NSS/I2S2_WS, SPI3_MOSI/I2S3_SDO, USART2_RX, TIM5_CH4, ETH1_MII_COL, XSPI1_CLK, COMP1_OUT, EVENTOUT	ADC1_IN3, ADC2_IN3
-	-	-	-	18	18	22	27	38	VSS	S	-	-	-	-
-	-	-	-	19	19	23	28	39	VDD	S	-	-	-	-
10	10	14	14	20	20	24	29	40	PA4	I/O	TT_a	-	TIM3_CH4, SPI3_MOSI/ I2S3_SDO, SPI1_NSS/I2S1_WS, SPI3_NSS/I2S3_WS, USART2_CK, TIM5_ETR, EVENTOUT	ADC1_IN4, DAC1_OUT1



Pin Number									Pin name (function after reset)	Pin type	I/O structure	Notes	Alternate functions	Additional functions
UFQFPN32	LQFP32	LQFP48	UFQFPN48	LQFP64	VFQFPN68	LQFP80	LQFP100	LQFP144						
11	11	15	15	21	21	25	30	41	PA5	I/O	FT_a	-	TIM2_CH1, TIM1_CH3, TIM8_CH1N, SPI1_SCK/I2S1_CK, SPI2_SCK/I2S2_CK, USART1_CTS/USART1_NSS, XSPI1_IO1, ETH1_MII_TX_EN/ETH1_RMII_TX_EN, XSPI1_NCS1, TIM2_ETR, EVENTOUT	ADC1_IN5, COMP1_INM3
12	12	16	16	22	22	26	31	42	PA6	I/O	FT_a	-	TIM1_BKIN, TIM3_CH1, TIM8_BKIN, SPI1_MISO/I2S1_SDI, USART1_TX, LPUART1_RTS, XSPI1_IO3, EVENTOUT	ADC1_IN6
13	13	17	17	23	23	27	32	43	PA7	I/O	FT_a	-	TIM1_CH1N, TIM3_CH2, TIM8_CH1N, TIM15_CH1, SPI1_MOSI/I2S1_SDO, SPI2_MISO/I2S2_SDI, USART1_RX, LPUART1_CTS, ETH1_MII_RX_DV/ETH1_RMII_CRS_DV, XSPI1_IO2, EVENTOUT	ADC1_IN7
-	-	-	-	24	24	28	33	44	PC4	I/O	FT_a	-	TIM2_CH4, TIM8_BKIN, I2S1_MCK, USART3_RX, TIM16_CH1, ETH1_MII_RXD0/ETH1_RMII_RXD0, EVENTOUT	ADC2_IN4, COMP1_INM1
-	-	-	-	25	25	29	34	45	PC5	I/O	FT_a	-	TIM1_CH4N, TIM8_BKIN2, TIM16_CH1N, XSPI1_DQS, ETH1_MII_RXD1/ETH1_RMII_RXD1, COMP1_OUT, EVENTOUT	ADC2_IN5
14	14	18	18	26	26	30	35	46	PB0	I/O	FT_a	-	TIM1_CH2N, TIM3_CH3, TIM8_CH2N, SPI3_MISO/I2S3_SDI, USART2_TX, UART4_CTS, ETH1_MII_RXD2, XSPI1_IO1, EVENTOUT	ADC2_IN6, ADC3_IN0, COMP1_INP2
15	-	19	19	27	27	31	36	47	PB1	I/O	FT_a	-	TIM1_CH3N, TIM3_CH4, TIM8_CH3N, SPI3_SCK/I2S3_CK, SPI2_NSS/I2S2_WS, USART3_RX, ETH1_MII_RXD3, XSPI1_IO0, COMP1_OUT, EVENTOUT	ADC2_IN7, ADC3_IN1, COMP1_INM2



Pin Number									Pin name (function after reset)	Pin type	I/O structure	Notes	Alternate functions	Additional functions
UFQFPN32	LQFP32	LQFP48	UFQFPN48	LQFP64	VFQFPN68	LQFP80	LQFP100	LQFP144						
-	-	20	20	28	28	32	37	48	PB2	I/O	FT_a	-	RTC_OUT2, TIM8_CH4N, SPI1_RDY, LPTIM1_CH1, SPI2_SCK/I2S2_CK, SPI3_MOSI/I2S3_SDO, XSPI1_CLK, XSPI1_DQS, ETH1_MII_RXD0/ETH1_RMII_RXD0, EVENTOUT	ADC2_IN8, ADC3_IN2, COMP1_INP3, LSCO
-	-	-	-	-	-	-	-	49	PF11	I/O	FT	-	XSPI1_NCLK, EVENTOUT	-
-	-	-	-	-	-	-	-	50	PF12	I/O	FT	-	EVENTOUT	-
-	-	-	-	-	-	-	-	51	VSS	S		-	-	-
-	-	-	-	-	-	-	-	52	VDD	S		-	-	-
-	-	-	-	-	-	-	-	53	PF13	I/O	FT	-	EVENTOUT	-
-	-	-	-	-	-	-	-	54	PF14	I/O	FT	-	TIM3_ETR, EVENTOUT	-
-	-	-	-	-	-	-	-	55	PF15	I/O	FT_f	-	TIM4_ETR, I3C1_SDA, ETH1_CLK, EVENTOUT	-
-	-	-	-	-	-	-	-	56	PG0	I/O	FT	-	TIM4_CH1, EVENTOUT	-
-	-	-	-	-	-	-	-	57	PG1	I/O	FT	-	TIM4_CH2, SPI2_MOSI/I2S2_SDO, EVENTOUT	-
-	-	-	-	-	29	33	38	58	PE7	I/O	FT	-	TIM1_ETR, UART7_RX, XSPI1_IO4, EVENTOUT	ADC3_IN3
-	-	-	-	-	-	34	39	59	PE8	I/O	FT_a	-	TIM1_CH1N, UART7_TX, XSPI1_IO5, EVENTOUT	ADC3_IN4
-	-	-	-	-	-	35	40	60	PE9	I/O	FT_a	-	TIM1_CH1, UART7_RTS, XSPI1_IO6, EVENTOUT	ADC3_IN5
-	-	-	-	-	-	-	-	61	VSS	S		-	-	-
-	-	-	-	-	-	-	-	62	VDD	S		-	-	-
-	-	-	-	-	-	36	41	63	PE10	I/O	FT_a	-	TIM1_CH2N, UART7_CTS, XSPI1_IO7, EVENTOUT	ADC3_IN6
-	-	-	-	-	-	-	42	64	PE11	I/O	FT_a	-	TIM1_CH2, SPI1_RDY, XSPI1_NCS1, EVENTOUT	ADC3_IN7
-	-	-	-	-	-	-	43	65	PE12	I/O	FT_a	-	TIM1_CH3N, ETH1_MDIO, COMP1_OUT, EVENTOUT	ADC3_IN8
-	-	-	-	-	-	-	44	66	PE13	I/O	FT_a	-	TIM1_CH3, EVENTOUT	ADC3_IN9



Pin Number									Pin name (function after reset)	Pin type	I/O structure	Notes	Alternate functions	Additional functions
UFQFPN32	LQFP32	LQFP48	UFQFPN48	LQFP64	VFQFPN68	LQFP80	LQFP100	LQFP144						
-	-	-	-	-	-	-	45	67	PE14	I/O	FT_a	-	TIM1_CH4, EVENTOUT	ADC3_IN10
-	-	-	-	-	-	-	46	68	PE15	I/O	FT_a	-	TIM1_BKIN, TIM1_CH4N, EVENTOUT	ADC3_IN11
-	-	21	21	29	30	37	47	69	PB10	I/O	FT_f	-	TIM2_CH3, TIM8_CH1, LPTIM1_IN1, I2C2_SCL, SPI2_SCK/I2S2_CK, USART3_TX, XSPI1_NCS1, ETH1_MII_RX_ER, EVENTOUT	-
16	15	22	22	30	31	38	48	70	VCAP	S		-	-	-
-	16	23	23	31	32	39	49	71	VSS	S		-	-	-
17	17	24	24	32	33	40	50	72	VDD	S		-	-	-
-	-	25	25	33	34	41	51	73	PB12	I/O	FT_f	-	TIM1_BKIN, TIM8_CH3, I2C2_SDA, SPI2_NSS/I2S2_WS, USART3_CK, FDCAN2_RX, ETH1_MII_TXD0/ETH1_RMII_TXD0, XSPI1_NCLK, UART5_RX, EVENTOUT	-
-	-	26	26	34	35	42	52	74	PB13	I/O	FT	-	TIM1_CH1N, TIM8_CH2, LPTIM1_CH1, I2C2_SMBA, SPI2_SCK/I2S2_CK, USART3_CTS/USART3_NSS, LPUART1_RX, FDCAN2_TX, ETH1_MII_TX_EN/ETH1_RMII_TX_EN, XSPI1_DQS, UART5_TX, EVENTOUT	-
-	-	27	27	35	36	43	53	75	PB14	I/O	FT	-	TIM1_CH2N, TIM12_CH1, TIM8_CH2N, USART1_TX, SPI2_MISO/I2S2_SDI, USART3_RTS, UART4_RTS, EVENTOUT	-



Pin Number									Pin name (function after reset)	Pin type	I/O structure	Notes	Alternate functions	Additional functions
UFQFPN32	LQFP32	LQFP48	UFQFPN48	LQFP64	VFQFPN68	LQFP80	LQFP100	LQFP144						
18	18	28	28	36	37	44	54	76	PB15	I/O	FT	-	RTC_REFIN, TIM1_CH3N, TIM12_CH2, TIM8_CH3N, USART1_RX, SPI2_MOSI/I2S2_SDO, SPI1_MOSI/I2S1_SDO, SPI3_MOSI/I2S3_SDO, UART4_CTS, XSPI1_IO0, ETH1_MII_TXD1/ETH1_RMII_TXD1, XSPI1_CLK, UART5_RX, EVENTOUT	-
-	-	-	-	-	-	-	55	77	PD8	I/O	FT	-	USART3_TX, ETH1_MII_RXD0/ETH1_RMII_RXD0, EVENTOUT	-
-	-	-	-	-	-	-	56	78	PD9	I/O	FT	-	USART3_RX, FDCAN2_RX, EVENTOUT	-
-	-	-	-	-	-	-	57	79	PD10	I/O	FT	-	MCO2, LPTIM1_CH2, USART3_CK, ETH1_MII_CRS, EVENTOUT	-
-	-	-	-	-	38	-	58	80	PD11	I/O	FT	-	LPTIM1_IN2, USART3_CTS/USART3_NSS, UART4_RX, XSPI1_IO0, ETH1_PTP_AUX_TS, EVENTOUT	-
-	-	-	-	-	39	45	59	81	PD12	I/O	FT_f	-	LPTIM1_IN1, TIM4_CH1, TIM8_CH1N, I3C1_SCL, USART3_RTS, UART4_TX, XSPI1_IO1, EVENTOUT	-
-	-	-	-	-	-	46	60	82	PD13	I/O	FT_f	-	LPTIM1_CH1, TIM4_CH2, TIM8_CH2N, I3C1_SDA, XSPI1_IO3, XSPI1_IO2, EVENTOUT	-
-	-	-	-	-	-	-	-	84	VDD	S		-	-	-
-	-	-	-	-	-	-	-	83	VSS	S		-	-	-
-	-	-	-	-	-	47	61	85	PD14	I/O	FT	-	TIM4_CH3, TIM8_CH3N, EVENTOUT	-
-	-	-	-	-	-	48	62	86	PD15	I/O	FT	-	TIM4_CH4, TIM8_CH4N, EVENTOUT	-
-	-	-	-	-	-	-	-	87	PG2	I/O	FT	-	TIM4_CH3, TIM8_BKIN, EVENTOUT	-



Pin Number									Pin name (function after reset)	Pin type	I/O structure	Notes	Alternate functions	Additional functions
UFQFPN32	LQFP32	LQFP48	UFQFPN48	LQFP64	VFQFPN68	LQFP80	LQFP100	LQFP144						
-	-	-	-	-	-	-	-	88	PG3	I/O	FT	-	TIM4_CH4, TIM8_BKIN2, UART7_RX, ETH1_MII_RX_ER, EVENTOUT	-
-	-	-	-	-	-	-	-	89	PG4	I/O	FT	-	TIM1_BKIN2, TIM5_CH1, EVENTOUT	-
-	-	-	-	-	-	-	-	90	PG5	I/O	FT	-	TIM1_ETR, TIM5_CH2, EVENTOUT	-
-	-	-	-	-	-	-	-	91	PG6	I/O	FT_f	-	TIM17_BKIN, TIM5_CH3, I3C1_SDA, SPI1_RDY, XSPI1_NCS1, EVENTOUT	-
-	-	-	-	-	-	-	-	92	PG7	I/O	FT_f	-	TIM5_CH4, I3C1_SCL, USART6_CK, EVENTOUT	-
-	-	-	-	-	-	-	-	93	PG8	I/O	FT	-	TIM5_ETR, TIM8_ETR, SPI3_MOSI/I2S3_SDO, USART6_RTS, ETH1_PPS_OUT, EVENTOUT	-
-	-	-	-	-	-	-	-	94	VSS	S		-	-	-
-	-	-	-	-	-	-	-	95	VDD	S		-	-	-
-	-	-	-	37	40	49	63	96	PC6	I/O	FT	-	TIM3_CH1, TIM8_CH1, I2S2_MCK, USART6_TX, XSPI1_IO5, XSPI1_IO3, EVENTOUT	-
-	-	-	-	38	41	50	64	97	PC7	I/O	FT	-	TIM3_CH2, TIM8_CH2, I2S3_MCK, USART6_RX, XSPI1_IO6, XSPI1_IO4, EVENTOUT	-
-	-	-	-	39	42	51	65	98	PC8	I/O	FT	-	TRACED1, TIM3_CH3, TIM8_CH3, USART6_CK, UART5_RTS, EVENTOUT	-
-	-	-	-	40	43	52	66	99	PC9	I/O	FT_f	-	MCO2, TIM3_CH4, TIM8_CH4, AUDIOCLK, XSPI1_IO0, UART5_CTS, I2C1_SDA, XSPI1_IO5, EVENTOUT	-



Pin Number									Pin name (function after reset)	Pin type	I/O structure	Notes	Alternate functions	Additional functions
UFQFPN32	LQFP32	LQFP48	UFQFPN48	LQFP64	VFQFPN68	LQFP80	LQFP100	LQFP144						
19	19	29	29	41	44	53	67	100	PA8	I/O	FT_f	-	MCO1, TIM1_CH1, I3C1_SDA, TIM8_BKIN2, TIM15_CH2, SPI1_RDY, SPI2_MOSI/I2S2_SDO, USART1_CK, TIM5_CH4, I2C1_SCL, UART7_RX, XSPI1_IO6, USB_SOF, TIM2_CH4, EVENTOUT	-
20	20	30	30	42	45	54	68	101	PA9	I/O	FT_f	-	MCO2, TIM1_CH2, I3C1_SCL, LPUART1_TX, TIM15_CH1N, SPI2_SCK/I2S2_CK, USART1_TX, TIM5_ETR, I2C1_SMBA, ETH1_MII_TX_ER, XSPI1_IO7, TIM8_CH2N, EVENTOUT	-
-	-	31	31	43	46	55	69	102	PA10	I/O	FT	-	TIM1_CH3, LPUART1_RX, USART1_RX, FDCAN2_TX, UART7_TX, XSPI1_CLK, ETH1_CLK, EVENTOUT	-
21	21	32	32	44	47	56	70	103	PA11	I/O	FT_f	-	TIM1_CH4, LPUART1_CTS, USART2_TX, SPI2_NSS/I2S2_WS, UART4_RX, USART1_CTS/USART1_NSS, I2C2_SCL, FDCAN1_RX, XSPI1_NCS2, EVENTOUT	USB_DM
22	22	33	33	45	48	57	71	104	PA12	I/O	FT_f	-	TIM1_ETR, LPUART1_RTS, USART2_RX, SPI2_SCK/I2S2_CK, UART4_TX, USART1_RTS, I2C2_SDA, FDCAN1_TX, EVENTOUT	USB_DP
23	23	34	34	46	49	58	72	105	PA13(JTMS/SWDIO)	I/O	FT	(3)	JTMS/SWDIO, COMP1_OUT, EVENTOUT	-
-	-	-	-	-	-	-	73	106	PH3	I/O	FT	-	EVENTOUT	-
-	-	35	35	47	50	59	74	107	VSS	S		-	-	-
-	-	36	36	48	51	60	75	108	VDD	S		-	-	-
24	24	37	37	49	52	61	76	109	PA14(JTCK/SWCLK)	I/O	FT	(3)	JTCK/SWCLK, EVENTOUT	-



Pin Number									Pin name (function after reset)	Pin type	I/O structure	Notes	Alternate functions	Additional functions
UFQFPN32	LQFP32	LQFP48	UFQFPN48	LQFP64	VFQFPN68	LQFP80	LQFP100	LQFP144						
25	25	38	38	50	53	62	77	110	PA15(JTDI)	I/O	FT	(3)	JTDI, TIM2_CH1, TIM1_CH2N, LPTIM1_ETR, I2C2_SMBA, SPI1_NSS/I2S1_WS, SPI3_NSS/I2S3_WS, USART2_CK, UART4_RTS, ETH1_PHY_INTN, USART1_TX, TIM8_CH4N, TIM2_ETR, EVENTOUT	-
-	-	-	-	51	54	63	78	111	PC10	I/O	FT_f	-	TIM8_CH1N, I3C1_SCL, SPI3_SCK/I2S3_CK, USART3_TX, UART4_TX, XSPI1_IO1, ETH1_MII_TXD0/ETH1_RMII_TXD0, EVENTOUT	-
-	-	-	-	52	55	64	79	112	PC11	I/O	FT_f	-	TIM8_CH2N, I3C1_SDA, SPI3_MISO/I2S3_SDI, USART3_RX, UART4_RX, XSPI1_NCS1, EVENTOUT	-
-	-	-	-	53	56	65	80	113	PC12	I/O	FT	-	TRACED3, TIM15_CH1, TIM8_CH3N, SPI3_MOSI/I2S3_SDO, USART3_CK, UART5_TX, ETH1_PPS_OUT, EVENTOUT	-
-	-	-	-	-	-	66	81	114	PD0	I/O	FT	-	TIM8_CH4N, UART4_RX, FDCAN1_RX, XSPI1_NCS2, EVENTOUT	-
-	-	-	-	-	-	67	82	115	PD1	I/O	FT	-	UART4_TX, FDCAN1_TX, ETH1_MII_RX_DV/ETH1_RMII_CRS_DV, EVENTOUT	-
-	-	-	-	54	-	68	83	116	PD2	I/O	FT	-	TRACED2, TIM3_ETR, TIM15_BKIN, UART5_RX, XSPI1_NCS2, EVENTOUT	WKUP7
-	-	-	-	-	-	-	84	117	PD3	I/O	FT	-	SPI2_SCK/I2S2_CK, USART2_CTS/USART2_NSS, EVENTOUT	-
-	-	-	-	-	-	-	85	118	PD4	I/O	FT	-	USART2_RTS, ETH1_CLK, XSPI1_IO4, EVENTOUT	-



Pin Number									Pin name (function after reset)	Pin type	I/O structure	Notes	Alternate functions	Additional functions
UFQFPN32	LQFP32	LQFP48	UFQFPN48	LQFP64	VFQFPN68	LQFP80	LQFP100	LQFP144						
-	-	-	-	-	-	-	86	119	PD5	I/O	FT	-	TIM1_CH4N, SPI2_RDY, USART2_TX, FDCAN1_TX, ETH1_MII_CRIS, XSPI1_IO5, EVENTOUT	-
-	-	-	-	-	-	-	-	120	VSS	S		-	-	-
-	-	-	-	-	-	-	-	121	VDD	S		-	-	-
-	-	-	-	-	-	-	87	122	PD6	I/O	FT	-	SPI3_MOSI/I2S3_SDO, USART2_RX, XSPI1_IO6, EVENTOUT	-
-	-	-	-	-	-	-	88	123	PD7	I/O	FT	-	SPI1_MOSI/I2S1_SDO, SPI3_MISO/I2S3_SDI, USART2_CK, XSPI1_IO7, EVENTOUT	-
-	-	-	-	-	-	-	-	124	PG9	I/O	FT	-	SPI1_MISO/I2S1_SDI, USART6_RX, XSPI1_IO6, EVENTOUT	-
-	-	-	-	-	-	-	-	125	PG10	I/O	FT	-	SPI1_NSS/I2S1_WS, USART6_CK, EVENTOUT	-
-	-	-	-	-	-	-	-	126	PG11	I/O	FT	-	LPTIM1_IN2, SPI1_SCK/I2S1_CK, ETH1_MII_TX_EN/ETH1_RMII_TX_EN, EVENTOUT	-
-	-	-	-	-	-	-	-	127	PG12	I/O	FT	-	LPTIM1_IN1, USART6_RTS, ETH1_MII_TXD1/ETH1_RMII_TXD1, EVENTOUT	-
-	-	-	-	-	-	-	-	128	PG13	I/O	FT	-	TRACED0, LPTIM1_CH1, USART6_CTS/USART6_NSS, ETH1_MII_TXD0/ETH1_RMII_TXD0, EVENTOUT	-
-	-	-	-	-	-	-	-	129	PG14	I/O	FT	-	TRACED1, LPTIM1_ETR, LPTIM1_CH2, USART6_TX, XSPI1_IO7, ETH1_MII_TXD1/ETH1_RMII_TXD1, EVENTOUT	-
-	-	-	-	-	-	-	-	130	VSS	S		-	-	-
-	-	-	-	-	-	-	-	131	VDD	S		-	-	-
-	-	-	-	-	-	-	-	132	PG15	I/O	FT	-	USART6_CTS/USART6_NSS, EVENTOUT	-



Pin Number									Pin name (function after reset)	Pin type	I/O structure	Notes	Alternate functions	Additional functions
UFQFPN32	LQFP32	LQFP48	UFQFPN48	LQFP64	VFQFPN68	LQFP80	LQFP100	LQFP144						
26	26	39	39	55	57	69	89	133	PB3(JTDO/TRACESWO)	I/O	FT_f	(3)	JTDO/TRACESWO, TIM2_CH2, TIM5_CH3, I2C2_SDA, SPI1_SCK/I2S1_CK, SPI3_SCK/I2S3_CK, LPUART1_TX, I2C2_SCL, CRS_SYNC, USART3_TX, ETH1_MDC, TIM8_CH1, UART5_RTS, EVENTOUT	(3)
27	27	40	40	56	58	70	90	134	PB4(NJTRST)	I/O	FT_f	(3)	NJTRST, TIM3_CH1, I3C1_SCL, LPTIM1_CH2, SPI1_MISO/I2S1_SDI, SPI3_MISO/I2S3_SDI, SPI2_NSS/I2S2_WS, LPUART1_CTS, I2C2_SDA, TIM16_BKIN, USART3_RX, ETH1_MDIO, TIM8_CH2, UART5_CTS, EVENTOUT	(3)
28	28	41	41	57	59	71	91	135	PB5	I/O	FT_f	-	TIM17_BKIN, TIM3_CH2, I3C1_SDA, I2C1_SMBA, SPI1_MOSI/I2S1_SDO, SPI3_MOSI/I2S3_SDO, LPUART1_RTS, FDCAN2_RX, ETH1_PPS_OUT, USART3_CK, TIM8_CH3, UART5_RX, EVENTOUT	-
29	29	42	42	58	60	72	92	136	PB6	I/O	FT_f	-	TIM4_CH1, I3C1_SCL, I2C1_SCL, SPI3_MISO/I2S3_SDI, USART1_TX, LPUART1_TX, FDCAN2_TX, TIM16_CH1N, USART3_CTS/USART3_NSS, ETH1_MII_TX_ER, TIM8_CH4, UART5_TX, EVENTOUT	-
30	30	43	43	59	61	73	93	137	PB7	I/O	FT_f	-	TIM17_CH1N, TIM4_CH2, I3C1_SDA, I2C1_SDA, SPI3_SCK/I2S3_CK, USART1_RX, LPUART1_RX, FDCAN1_TX, TIM16_CH1, USART3_RTS, EVENTOUT	WKUP5
31	-	44	44	60	62	74	94	138	PH2-BOOT0	I/O	FT	-	MCO1, TIM17_CH1N, LPTIM1_IN2, FDCAN1_RX, EVENTOUT	-



Pin Number									Pin name (function after reset)	Pin type	I/O structure	Notes	Alternate functions	Additional functions
UFQFPN32	LQFP32	LQFP48	UFQFPN48	LQFP64	VFQFPN68	LQFP80	LQFP100	LQFP144						
32	31	45	45	61	63	75	95	139	PB8	I/O	FT_f	-	TIM17_CH1, TIM4_CH3, I3C1_SCL, I2C1_SCL, SPI3_NSS/I2S3_WS, UART4_RX, FDCAN1_RX, ETH1_MII_TXD3, XSPI1_NCS1, EVENTOUT	-
-	-	46	46	62	64	76	96	140	PB9	I/O	FT_f	-	TIM4_CH4, I3C1_SDA, I2C1_SDA, SPI2_NSS/I2S2_WS, SPI3_SCK/I2S3_CK, UART4_TX, FDCAN1_TX, EVENTOUT	-
-	-	-	-	-	65	77	97	141	PE0	I/O	FT	-	LPTIM1_ETR, TIM4_ETR, SPI3_RDY, FDCAN1_RX, XSPI1_NCS2, EVENTOUT	-
-	-	-	-	-	66	78	98	142	PE1	I/O	FT	-	LPTIM1_IN2, FDCAN1_TX, EVENTOUT	-
-	32	47	47	63	67	79	99	143	VSS	S		-	-	-
1	1	48	48	64	68	80	100	144	VDD	S		-	-	-

1. After a RTC domain reset, PC13, PC14, and PC15 operate as GPIOs. Their function depends on the content of the RTC registers that are not reset by the system reset. For details on how to manage these GPIOs, refer to the backup domain and RTC register descriptions in the product reference manual.
2. Toggling the PC13 port can disturb the low-speed crystal connected to the LSE on PC14 and PC15. Refer to product errata sheet for more details.
3. After reset, this pin is configured for JTAG or SWD alternate function. The internal pull-up on the PA15, PA13, and PB4 pins, and the internal pull-down on the PA14 pin, are activated.



4.3 Alternate functions

Table 14. Alternate functions

Port	AF0	AF1	AF2	AF3	AF4	AF5	AF6	AF7	AF8	AF9	AF10	AF11	AF12	AF13	AF14	AF15	
	SYS	LPTIM1/ TIM1/2/17	I3C1/ TIM1/3/4/5/8/12/15	I3C1/LPTIM1/ LPUART1/ TIM1/5/8	I2C1/2/I3C1/ LPTIM1/ SPI1/I2S1/ SPI3/I2S3/ TIM1/9/ USART1/2	I3C1/ LPTIM1/ SPI1/I2S1/ SPI3/I2S3/ SPI3/ I2S3/SYS	SPI1/I2S1/ SPI2/I2S2/ SPI3/I2S3/ UART4	SPI2/I2S2/ SPI3/I2S3/ UART7/ USART1/2/3/6/ XSP1	I2C2/ LPUART1/ TIM5/UART4/5	FDCAN1/2/ I2C1/2/SPI2/ I2S2/XSP1	CRS/ETH1_/TIM16/ UART7	USART1/3/ XSP1	ETH1_	ETH1_/TIM8/ USB_	COMP/TIM2/ UART5	SYS	
Port A	PA0	-	TIM2_CH1	TIM5_CH1	TIM8_ETR	TIM15_BKIN	SPI2_RDY	SPI3_RDY	USART2_CTS/ USART2_NSS	UART4_TX	SPI2_NSS/ I2S2_WS	ETH1_MII_CRS	XSP1_IO3	-	-	TIM2_ETR	EVENTOUT
	PA1	-	TIM2_CH2	TIM5_CH2	TIM8_BKIN	TIM15_CH1N	LPTIM1_IN1	-	USART2_RTS	UART4_RX	XSP1_IO3	ETH1_MII_RX_CLK/ ETH1_RMII_REF_CLK	XSP1_DQS	-	-	-	EVENTOUT
	PA2	-	TIM2_CH3	TIM5_CH3	LPUART1_RX	TIM15_CH1	LPTIM1_IN2	-	USART2_TX	-	-	ETH1_MDIO	XSP1_NCLK	-	-	-	EVENTOUT
	PA3	-	TIM2_CH4	TIM3_CH3	LPUART1_TX	TIM15_CH2	SPI2_NSS/ I2S2_WS	SPI3_MOSI/ I2S3_SDO	USART2_RX	TIM5_CH4	-	ETH1_MII_COL	XSP1_CLK	-	-	COMP1_OUT	EVENTOUT
	PA4	-	-	TIM3_CH4	-	SPI3_MOSI/ I2S3_SDO	SPI1_NSS/ I2S1_WS	SPI3_NSS/ I2S3_WS	USART2_CK	TIM5_ETR	-	-	-	-	-	-	EVENTOUT
	PA5	-	TIM2_CH1	TIM1_CH3	TIM8_CH1N	-	SPI1_SCK/ I2S1_CK	SPI2_SCK/ I2S2_CK	USART1_CTS/ USART1_NSS	-	XSP1_IO1	ETH1_MII_RX_EN/ ETH1_RMII_TX_EN	XSP1_NCS1	-	-	TIM2_ETR	EVENTOUT
	PA6	-	TIM1_BKIN	TIM3_CH1	TIM8_BKIN	-	SPI1_MISO/ I2S1_SDI	-	USART1_TX	LPUART1_RTS	XSP1_IO3	-	-	-	-	-	EVENTOUT
	PA7	-	TIM1_CH1N	TIM3_CH2	TIM8_CH1N	TIM15_CH1	SPI1_MOSI/ I2S1_SDO	SPI2_MISO/ I2S2_SDI	USART1_RX	LPUART1_CTS	-	ETH1_MII_RX_DV/ ETH1_RMII_CRS_DV	XSP1_IO2	-	-	-	EVENTOUT
	PA8	MCO1	TIM1_CH1	I3C1_SDA	TIM8_BKIN2	TIM15_CH2	SPI1_RDY	SPI2_MOSI/ I2S2_SDO	USART1_CK	TIM5_CH4	I2C1_SCL	UART7_RX	XSP1_IO6	-	USB_SOF	TIM2_CH4	EVENTOUT
	PA9	MCO2	TIM1_CH2	I3C1_SCL	LPUART1_TX	TIM15_CH1N	SPI2_SCK/ I2S2_CK	-	USART1_TX	TIM5_ETR	I2C1_SMBA	ETH1_MII_TX_ER	XSP1_IO7	-	TIM8_CH2N	-	EVENTOUT
	PA10	-	TIM1_CH3	-	LPUART1_RX	-	-	-	USART1_RX	-	FDCAN2_TX	UART7_TX	XSP1_CLK	-	ETH1_CLK	-	EVENTOUT
	PA11	-	TIM1_CH4	-	LPUART1_CTS	USART2_TX	SPI2_NSS/ I2S2_WS	UART4_RX	USART1_CTS/ USART1_NSS	I2C2_SCL	FDCAN1_RX	-	XSP1_NCS2	-	-	-	EVENTOUT
	PA12	-	TIM1_ETR	-	LPUART1_RTS	USART2_RX	SPI2_SCK/ I2S2_CK	UART4_TX	USART1_RTS	I2C2_SDA	FDCAN1_TX	-	-	-	-	-	EVENTOUT
	PA13	JTMS/SWDIO	-	-	-	-	-	-	-	-	-	-	-	-	-	COMP1_OUT	EVENTOUT
	PA14	JTCK/SWCLK	-	-	-	-	-	-	-	-	-	-	-	-	-	-	EVENTOUT
PA15	JTDI	TIM2_CH1	TIM1_CH2N	LPTIM1_ETR	I2C2_SMBA	SPI1_NSS/ I2S1_WS	SPI3_NSS/ I2S3_WS	USART2_CK	UART4_RTS	-	ETH1_PHY_INTN	USART1_TX	-	TIM8_CH4N	TIM2_ETR	EVENTOUT	
Port B	PB0	-	TIM1_CH2N	TIM3_CH3	TIM8_CH2N	-	SPI3_MISO/ I2S3_SDI	-	USART2_TX	UART4_CTS	-	ETH1_MII_RXD2	XSP1_IO1	-	-	-	EVENTOUT
	PB1	-	TIM1_CH3N	TIM3_CH4	TIM8_CH3N	SPI3_SCK/ I2S3_CK	SPI2_NSS/ I2S2_WS	-	USART3_RX	-	-	ETH1_MII_RXD3	XSP1_IO0	-	-	COMP1_OUT	EVENTOUT
	PB2	RTC_OUT2	-	-	TIM8_CH4N	SPI1_RDY	LPTIM1_CH1	SPI2_SCK/ I2S2_CK	SPI3_MOSI/ I2S3_SDO	-	XSP1_CLK	-	XSP1_DQS	-	ETH1_MII_RXD0/ ETH1_RMII_RXD0	-	EVENTOUT
	PB3	JTDO/ TRACESWO	TIM2_CH2	-	TIM5_CH3	I2C2_SDA	SPI1_SCK/ I2S1_CK	SPI3_SCK/ I2S3_CK	-	LPUART1_TX	I2C2_SCL	CRS_SYNC	USART3_TX	ETH1_MDC	TIM8_CH1	UART5_RTS	EVENTOUT
	PB4	NJTRST	-	TIM3_CH1	I3C1_SCL	LPTIM1_CH2	SPI1_MISO/ I2S1_SDI	SPI3_MISO/ I2S3_SDI	SPI2_NSS/ I2S2_WS	LPUART1_CTS	I2C2_SDA	TIM16_BKIN	USART3_RX	ETH1_MDIO	TIM8_CH2	UART5_CTS	EVENTOUT
	PB5	-	TIM17_BKIN	TIM3_CH2	I3C1_SDA	I2C1_SMBA	SPI1_MOSI/ I2S1_SDO	-	SPI3_MOSI/ I2S3_SDO	LPUART1_RTS	FDCAN2_RX	ETH1_PPS_OUT	USART3_CK	-	TIM8_CH3	UART5_RX	EVENTOUT
	PB6	-	-	TIM4_CH1	I3C1_SCL	I2C1_SCL	-	SPI3_MISO/ I2S3_SDI	USART1_TX	LPUART1_TX	FDCAN2_TX	TIM16_CH1N	USART3_CTS/ USART3_NSS	ETH1_MII_TX_ER	TIM8_CH4	UART5_TX	EVENTOUT
	PB7	-	TIM17_CH1N	TIM4_CH2	I3C1_SDA	I2C1_SDA	-	SPI3_SCK/ I2S3_CK	USART1_RX	LPUART1_RX	FDCAN1_TX	TIM16_CH1	USART3_RTS	-	-	-	EVENTOUT





Port	AF0	AF1	AF2	AF3	AF4	AF5	AF6	AF7	AF8	AF9	AF10	AF11	AF12	AF13	AF14	AF15		
	SYS	LPTIM1/ TIM1/2/17	I3C1/ TIM1/3/4/5/8/12/15	I3C1/LPTIM1/ LPUART1/ TIM1/5/8	I2C1/2/I3C1/ LP TIM1/ SPI1/I2S1/ SPI3/I2S3/ TIM15/ USART1/2	I3C1/ LP TIM1/ SPI1/I2S1/ SPI2/I2S2/ SPI3/ I2S3/SYS	SPI1/I2S1/ SPI2/I2S2/ SPI3/I2S3/ UART4	SPI2/I2S2/ SPI3/I2S3/ UART7/ USART1/2/3/6/ XSPI1	I2C2/ LPUART1/ TIM5/UART4/5	FDCAN1/2/ I2C1/2/SPI2/ I2S2/XSPI1	CRS/ETH1_ TIM16/ UART7	USART1/3/ XSPI1	ETH1_ ETH1_ USB_ COMP/TIM2/ UART5	SYS				
Port B	PB8	-	TIM17_CH1	TIM4_CH3	I3C1_SCL	I2C1_SCL	-	SPI3_NSS/ I2S3_WS	-	UART4_RX	FDCAN1_RX	ETH1_MII_TXD3	XSPI1_NCS1	-	-	-	EVENTOUT	
	PB9	-	-	TIM4_CH4	I3C1_SDA	I2C1_SDA	SPI2_NSS/ I2S2_WS	SPI3_SCK/ I2S3_CK	-	UART4_TX	FDCAN1_TX	-	-	-	-	-	EVENTOUT	
	PB10	-	TIM2_CH3	TIM8_CH1	LPTIM1_IN1	I2C2_SCL	SPI2_SCK/ I2S2_CK	-	USART3_TX	-	XSPI1_NCS1	ETH1_MII_RX_ER	-	-	-	-	EVENTOUT	
	PB12	-	TIM1_BKIN	TIM8_CH3	-	I2C2_SDA	SPI2_NSS/ I2S2_WS	-	USART3_CK	-	FDCAN2_RX	ETH1_MII_TXD0/ ETH1_RMII_TXD0	XSPI1_NCLK	-	-	-	UART5_RX	EVENTOUT
	PB13	-	TIM1_CH1N	TIM8_CH2	LPTIM1_CH1	I2C2_SMBA	SPI2_SCK/ I2S2_CK	-	USART3_CTS/ USART3_NSS	LPUART1_RX	FDCAN2_TX	ETH1_MII_TX_EN/ ETH1_RMII_TX_EN	XSPI1_DQS	-	-	-	UART5_TX	EVENTOUT
	PB14	-	TIM1_CH2N	TIM12_CH1	TIM8_CH2N	USART1_TX	SPI2_MISO/ I2S2_SDI	-	USART3_RTS	UART4_RTS	-	-	-	-	-	-	-	EVENTOUT
	PB15	RTC_REFIN	TIM1_CH3N	TIM12_CH2	TIM8_CH3N	USART1_RX	SPI2_MOSI/ I2S2_SDO	SPI1_MOSI/ I2S1_SDO	SPI3_MOSI/ I2S3_SDO	UART4_CTS	XSPI1_IO0	ETH1_MII_TXD1/ ETH1_RMII_TXD1	XSPI1_CLK	-	-	-	UART5_RX	EVENTOUT
Port C	PC0	-	-	-	-	-	-	SPI2_RDY	-	-	TIM16_BKIN	XSPI1_IO7	-	-	-	-	EVENTOUT	
	PC1	TRACED0	-	-	-	-	SPI2_MOSI/ I2S2_SDO	-	-	-	XSPI1_IO4	ETH1_MDC	XSPI1_IO6	-	-	-	EVENTOUT	
	PC2	PWR_CSLEEP	TIM17_CH1	TIM4_CH4	-	-	SPI2_MISO/ I2S2_SDI	-	-	-	XSPI1_IO2	ETH1_MII_TXD2	XSPI1_IO5	-	-	-	EVENTOUT	
	PC3	PWR_CSTOP	-	-	LPUART1_TX	-	SPI2_MOSI/ I2S2_SDO	-	XSPI1_IO6	-	XSPI1_IO0	ETH1_MII_TX_CLK	XSPI1_IO4	-	-	-	-	EVENTOUT
	PC4	-	TIM2_CH4	-	TIM8_BKIN	-	I2S1_MCK	-	USART3_RX	-	-	TIM16_CH1	-	ETH1_MII_RXD0/ ETH1_RMII_RXD0	-	-	-	EVENTOUT
	PC5	-	TIM1_CH4N	-	TIM8_BKIN2	-	-	-	-	-	-	TIM16_CH1N	XSPI1_DQS	-	ETH1_MII_RXD1/ ETH1_RMII_RXD1	COMP1_OUT	-	EVENTOUT
	PC6	-	-	TIM3_CH1	TIM8_CH1	-	I2S2_MCK	-	USART6_TX	-	XSPI1_IO5	-	XSPI1_IO3	-	-	-	-	EVENTOUT
	PC7	-	-	TIM3_CH2	TIM8_CH2	-	-	I2S3_MCK	USART6_RX	-	XSPI1_IO6	-	XSPI1_IO4	-	-	-	-	EVENTOUT
	PC8	TRACED1	-	TIM3_CH3	TIM8_CH3	-	-	-	USART6_CK	UART5_RTS	-	-	-	-	-	-	-	EVENTOUT
	PC9	MCO2	-	TIM3_CH4	TIM8_CH4	-	AUDIOCLK	-	XSPI1_IO0	UART5_CTS	I2C1_SDA	-	XSPI1_IO5	-	-	-	-	EVENTOUT
	PC10	-	-	-	TIM8_CH1N	I3C1_SCL	-	SPI3_SCK/ I2S3_CK	USART3_TX	UART4_TX	XSPI1_IO1	ETH1_MII_TXD0/ ETH1_RMII_TXD0	-	-	-	-	-	EVENTOUT
	PC11	-	-	-	TIM8_CH2N	I3C1_SDA	-	SPI3_MISO/ I2S3_SDI	USART3_RX	UART4_RX	XSPI1_NCS1	-	-	-	-	-	-	EVENTOUT
	PC12	TRACED3	-	TIM15_CH1	TIM8_CH3N	-	-	SPI3_MOSI/ I2S3_SDO	USART3_CK	UART5_TX	-	ETH1_PPS_OUT	-	-	-	-	-	EVENTOUT
	PC13	-	-	-	-	-	-	-	-	-	FDCAN1_TX	-	-	-	-	-	-	EVENTOUT
	PC14	-	-	TIM12_CH1	-	-	-	-	-	-	FDCAN1_RX	-	-	-	-	-	-	EVENTOUT
PC15	-	-	TIM12_CH2	-	-	-	-	-	-	-	-	-	-	-	-	-	EVENTOUT	
Port D	PD0	-	-	-	TIM8_CH4N	-	-	-	UART4_RX	FDCAN1_RX	-	XSPI1_NCS2	-	-	-	-	EVENTOUT	
	PD1	-	-	-	-	-	-	-	UART4_TX	FDCAN1_TX	ETH1_MII_RX_DV/ ETH1_RMII_CRS_DV	-	-	-	-	-	EVENTOUT	
	PD2	TRACED2	-	TIM3_ETR	-	TIM15_BKIN	-	-	UART5_RX	XSPI1_NCS2	-	-	-	-	-	-	EVENTOUT	
	PD3	-	-	-	-	-	SPI2_SCK/ I2S2_CK	-	USART2_CTS/ USART2_NSS	-	-	-	-	-	-	-	-	EVENTOUT
	PD4	-	-	-	-	-	-	USART2_RTS	-	-	ETH1_CLK	XSPI1_IO4	-	-	-	-	EVENTOUT	
	PD5	-	TIM1_CH4N	-	-	-	-	SPI2_RDY	USART2_TX	-	FDCAN1_TX	ETH1_MII_CRS	XSPI1_IO5	-	-	-	-	EVENTOUT



Port	AF0	AF1	AF2	AF3	AF4	AF5	AF6	AF7	AF8	AF9	AF10	AF11	AF12	AF13	AF14	AF15
	SYS	LPTIM1/ TIM1/2/17	I3C1/ TIM1/3/4/5/8/12/15	I3C1/LPTIM1/ LPUART1/ TIM1/5/8	I2C1/2/I3C1/ LPTIM1/ SPI1/I2S1/ SPI2/I2S2/ SPI3/ TIM15/ USART1/2	I3C1/ LPTIM1/ SPI1/I2S1/ SPI2/I2S2/ SPI3/ I2S3/SYS	SPI1/I2S1/ SPI2/I2S2/ SPI3/I2S3/ UART4	SPI2/I2S2/ SPI3/I2S3/ UART7/ USART1/2/3/6/ XSP1	I2C2/ LPUART1/ TIM5/UART4/5	FDCAN1/2/ I2C1/2/SPI2/ I2S2/XSP1	CRS/ETH1_ _TIM16/ UART7	USART1/3/ XSP1	ETH1_ _	ETH1_ _TIM8/ _USB_ _	COMP/TIM2/ UART5	SYS
Port D	PD6	-	-	-	-	SPI3_MOS/ I2S3_SDO	-	USART2_RX	-	-	-	XSP1_IO6	-	-	-	EVENTOUT
	PD7	-	-	-	-	SPI1_MOS/ I2S1_SDO	SPI3_MISO/ I2S3_SDI	USART2_CK	-	-	-	XSP1_IO7	-	-	-	EVENTOUT
	PD8	-	-	-	-	-	-	USART3_TX	-	-	ETH1_MII_RXD0/ ETH1_RMII_RXD0	-	-	-	-	EVENTOUT
	PD9	-	-	-	-	-	-	USART3_RX	-	FDCAN2_RX	-	-	-	-	-	EVENTOUT
	PD10	MCO2	LPTIM1_CH2	-	-	-	-	USART3_CK	-	-	ETH1_MII_CRS	-	-	-	-	EVENTOUT
	PD11	-	LPTIM1_IN2	-	-	-	-	USART3_CTS/ USART3_NSS	UART4_RX	XSP1_IO0	ETH1_PTP_AUX_TS	-	-	-	-	EVENTOUT
	PD12	-	LPTIM1_IN1	TIM4_CH1	TIM8_CH1N	-	I3C1_SCL	-	USART3_RTS	UART4_TX	XSP1_IO1	-	-	-	-	EVENTOUT
	PD13	-	LPTIM1_CH1	TIM4_CH2	TIM8_CH2N	-	I3C1_SDA	-	-	-	XSP1_IO3	-	XSP1_IO2	-	-	EVENTOUT
	PD14	-	-	TIM4_CH3	TIM8_CH3N	-	-	-	-	-	-	-	-	-	-	EVENTOUT
	PD15	-	-	TIM4_CH4	TIM8_CH4N	-	-	-	-	-	-	-	-	-	-	EVENTOUT
Port E	PE0	-	LPTIM1_ETR	TIM4_ETR	-	-	SPI3_RDY	-	-	FDCAN1_RX	-	XSP1_NCS2	-	-	-	EVENTOUT
	PE1	-	LPTIM1_IN2	-	-	-	-	-	-	FDCAN1_TX	-	-	-	-	-	EVENTOUT
	PE2	TRACECLK	LPTIM1_IN2	-	-	SPI3_SCK/ I2S3_CK	-	-	-	XSP1_IO2	ETH1_MII_TXD3	-	-	-	-	EVENTOUT
	PE3	TRACED0	-	-	-	TIM15_BKIN	-	USART1_RX	-	-	-	-	-	-	-	EVENTOUT
	PE4	TRACED1	-	-	-	TIM15_CH1N	SPI3_NSS/ I2S3_WS	USART1_TX	-	-	ETH1_MII_RXD0/ ETH1_RMII_RXD0	-	-	-	-	EVENTOUT
	PE5	TRACED2	-	-	-	TIM15_CH1	SPI3_MISO/ I2S3_SDI	USART1_CK	-	-	ETH1_MII_RXD1/ ETH1_RMII_RXD1	-	-	-	-	EVENTOUT
	PE6	TRACED3	TIM1_BKIN2	-	-	TIM15_CH2	SPI3_MOS/ I2S3_SDO	USART1_CTS/ USART1_NSS	-	-	-	-	-	-	-	EVENTOUT
	PE7	-	TIM1_ETR	-	-	-	-	UART7_RX	-	-	-	XSP1_IO4	-	-	-	EVENTOUT
	PE8	-	TIM1_CH1N	-	-	-	-	UART7_TX	-	-	-	XSP1_IO5	-	-	-	EVENTOUT
	PE9	-	TIM1_CH1	-	-	-	-	UART7_RTS	-	-	-	XSP1_IO6	-	-	-	EVENTOUT
	PE10	-	TIM1_CH2N	-	-	-	-	UART7_CTS	-	-	-	XSP1_IO7	-	-	-	EVENTOUT
	PE11	-	TIM1_CH2	-	-	SPI1_RDY	-	-	-	-	-	XSP1_NCS1	-	-	-	EVENTOUT
	PE12	-	TIM1_CH3N	-	-	-	-	-	-	-	ETH1_MDIO	-	-	-	COMP1_OUT	EVENTOUT
	PE13	-	TIM1_CH3	-	-	-	-	-	-	-	-	-	-	-	-	EVENTOUT
	PE14	-	TIM1_CH4	-	-	-	-	-	-	-	-	-	-	-	-	EVENTOUT
PE15	-	TIM1_BKIN	-	TIM1_CH4N	-	-	-	-	-	-	-	-	-	-	EVENTOUT	
Port F	PF0	-	-	-	I2C2_SDA	-	-	-	-	-	-	-	-	-	-	EVENTOUT
	PF1	-	-	-	I2C2_SCL	-	-	-	-	-	-	-	-	-	-	EVENTOUT
	PF2	-	-	-	I2C2_SMBA	-	-	-	-	-	-	-	-	-	-	EVENTOUT
	PF3	-	-	-	-	-	-	-	-	-	-	-	-	-	-	EVENTOUT
	PF4	-	-	-	-	-	-	-	-	-	-	-	-	-	-	EVENTOUT
	PF5	-	-	-	-	I3C1_SCL	-	-	-	-	-	-	-	-	-	EVENTOUT
	PF6	-	-	-	-	-	-	UART7_RX	-	-	TIM16_CH1	XSP1_IO3	-	-	-	EVENTOUT
	PF7	-	TIM17_CH1	-	-	-	-	UART7_TX	-	-	-	XSP1_IO2	-	-	-	EVENTOUT



Port	AF0	AF1	AF2	AF3	AF4	AF5	AF6	AF7	AF8	AF9	AF10	AF11	AF12	AF13	AF14	AF15	
	SYS	LPTIM1/ TIM1/2/17	I3C1/ TIM1/3/4/5/8/12/15	I3C1/LPTIM1/ LPUART1/ TIM1/5/8	I2C1/2/I3C1/ LPTIM1/ SPI1/I2S1/ SPI3/I2S3/ TIM15/ USART1/2	I3C1/ LPTIM1/ SPI1/I2S1/ SPI2/I2S2/ SPI3/ I2S3/SYS	SPI1/I2S1/ SPI2/I2S2/ SPI3/I2S3/ UART4	SPI2/I2S2/ SPI3/I2S3/ UART7/ USART1/2/3/6/ XSP1	I2C2/ LPUART1/ TIM5/UART4/5	FDCAN1/2/ I2C1/2/SPI2/ I2S2/XSP1	CRS/ETH1_ _TIM16/ UART7	USART1/3/ XSP1	ETH1_ _	ETH1_ _TIM8/ _USB_ _	COMP/TIM2/ UART5	SYS	
Port F	PF8	-	-	-	-	-	-	UART7_RTS	-	-	TIM16_CH1N	XSP1_IO1	-	ETH1_MII_TX_ER	-	EVENTOUT	
	PF9	-	TIM17_CH1N	-	-	-	-	UART7_CTS	-	-	ETH1_MDC	XSP1_IO0	-	-	-	EVENTOUT	
	PF10	-	-	-	-	-	-	-	-	XSP1_CLK	TIM16_BKIN	-	-	-	-	EVENTOUT	
	PF11	-	-	-	-	-	-	-	-	XSP1_NCLK	-	-	-	-	-	EVENTOUT	
	PF12	-	-	-	-	-	-	-	-	-	-	-	-	-	-	EVENTOUT	
	PF13	-	-	-	-	-	-	-	-	-	-	-	-	-	-	EVENTOUT	
	PF14	-	-	TIM3_ETR	-	-	-	-	-	-	-	-	-	-	-	EVENTOUT	
	PF15	-	-	TIM4_ETR	-	-	I3C1_SDA	-	-	-	-	ETH1_CLK	-	-	-	EVENTOUT	
Port G	PG0	-	-	TIM4_CH1	-	-	-	-	-	-	-	-	-	-	-	EVENTOUT	
	PG1	-	-	TIM4_CH2	-	-	-	SPI2_MOSI/ I2S2_SDO	-	-	-	-	-	-	-	EVENTOUT	
	PG2	-	-	TIM4_CH3	TIM8_BKIN	-	-	-	-	-	-	-	-	-	-	EVENTOUT	
	PG3	-	-	TIM4_CH4	TIM8_BKIN2	-	-	-	-	-	-	UART7_RX	-	-	ETH1_MII_RX_ER	-	EVENTOUT
	PG4	-	TIM1_BKIN2	TIM5_CH1	-	-	-	-	-	-	-	-	-	-	-	EVENTOUT	
	PG5	-	TIM1_ETR	TIM5_CH2	-	-	-	-	-	-	-	-	-	-	-	EVENTOUT	
	PG6	-	TIM17_BKIN	TIM5_CH3	I3C1_SDA	-	SPI1_RDY	-	-	-	-	-	XSP1_NCS1	-	-	-	EVENTOUT
	PG7	-	-	TIM5_CH4	I3C1_SCL	-	-	-	USART6_CK	-	-	-	-	-	-	-	EVENTOUT
	PG8	-	-	TIM5_ETR	TIM8_ETR	-	SPI3_MOSI/ I2S3_SDO	-	USART6_RTS	-	-	ETH1_PPS_OUT	-	-	-	-	EVENTOUT
	PG9	-	-	-	-	-	SPI1_MISO/ I2S1_SDI	-	USART6_RX	-	XSP1_IO6	-	-	-	-	-	EVENTOUT
	PG10	-	-	-	-	-	SPI1_NSS/ I2S1_WS	-	USART6_CK	-	-	-	-	-	-	-	EVENTOUT
	PG11	-	LPTIM1_IN2	-	-	-	SPI1_SCK/ I2S1_CK	-	-	-	-	ETH1_MII_TX_EN/ ETH1_RMII_TX_EN	-	-	-	-	EVENTOUT
	PG12	-	LPTIM1_IN1	-	-	-	-	-	USART6_RTS	-	-	ETH1_MII_TXD1/ ETH1_RMII_TXD1	-	-	-	-	EVENTOUT
	PG13	TRACED0	LPTIM1_CH1	-	-	-	-	-	USART6_CTS/ USART6_NSS	-	-	ETH1_MII_TXD0/ ETH1_RMII_TXD0	-	-	-	-	EVENTOUT
	PG14	TRACED1	LPTIM1_ETR	-	-	LPTIM1_CH2	-	-	USART6_TX	-	XSP1_IO7	ETH1_MII_TXD1/ ETH1_RMII_TXD1	-	-	-	-	EVENTOUT
	PG15	-	-	-	-	-	-	-	USART6_CTS/ USART6_NSS	-	-	-	-	-	-	-	EVENTOUT
	Port H	PH0	-	-	-	I2C1_SDA	-	-	-	-	-	-	-	-	-	-	EVENTOUT
PH1		-	-	-	I2C1_SCL	-	-	-	-	-	-	-	-	-	-	EVENTOUT	
PH2		MCO1	TIM17_CH1N	-	LPTIM1_IN2	-	-	-	-	FDCAN1_RX	-	-	-	-	-	EVENTOUT	
PH3		-	-	-	-	-	-	-	-	-	-	-	-	-	-	EVENTOUT	
PH4		-	-	-	-	-	-	-	-	-	-	-	-	-	-	EVENTOUT	
PH5		-	-	-	-	-	-	-	-	-	-	-	-	-	-	EVENTOUT	
PH15	-	-	-	-	-	-	-	USART1_RTS	-	-	-	-	-	-	-	EVENTOUT	

5 Electrical characteristics

5.1 Parameter conditions

Unless otherwise specified, all voltages are referenced to V_{SS} .

5.1.1 Minimum and maximum values

Unless otherwise specified the minimum and maximum values are guaranteed in the worst conditions of junction temperature, supply voltage and frequencies by tests in production on 100 % of the devices with an junction temperature at $T_J = 25\text{ }^\circ\text{C}$ and $T_J = T_{Jmax}$ (given by the selected temperature range).

Data based on characterization results, design simulation and/or technology characteristics are indicated in the table footnotes. Based on characterization, the minimum and maximum values refer to sample tests and represent the mean value plus or minus three times the standard deviation (mean $\pm 3\sigma$).

5.1.2 Typical values

Unless otherwise specified, typical data are based on $T_J = 25\text{ }^\circ\text{C}$, $V_{DD} = 3.3\text{ V}$ (for the $2.7\text{ V} \leq V_{DD} \leq 3.6\text{ V}$ voltage range). They are given only as design guidelines and are not tested.

Typical ADC accuracy values are determined by characterization of a batch of samples from a standard diffusion lot over the full temperature range, where 95% of the devices have an error less than or equal to the value indicated (mean $\pm 2\sigma$).

5.1.3 Typical curves

Unless otherwise specified, all typical curves are given only as design guidelines and are not tested.

5.1.4 Loading capacitor

The loading conditions used for pin parameter measurement are shown in Figure 11.

5.1.5 Pin input voltage

The input voltage measurement on a pin of the device is described in Figure 12.

Figure 11. Pin loading conditions

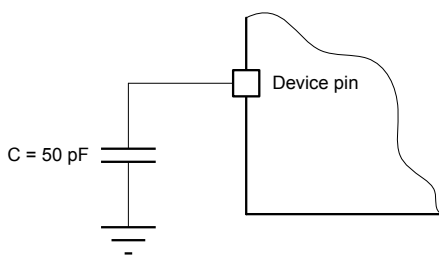

DT147493V1

Figure 12. Pin input voltage

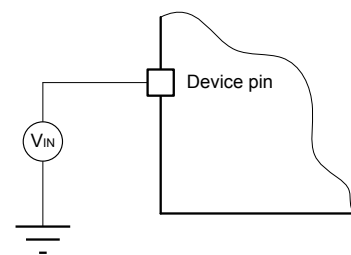

DT147494V1

5.1.6 Power supply scheme

Each power supply pair must be decoupled with filtering ceramic capacitors as shown in the following figures. These capacitors must be placed as close as possible to, or below, the appropriate pins on the underside of the PCB to ensure the proper functionality of the device.

Figure 13. STM32C5A3xxx power supply scheme

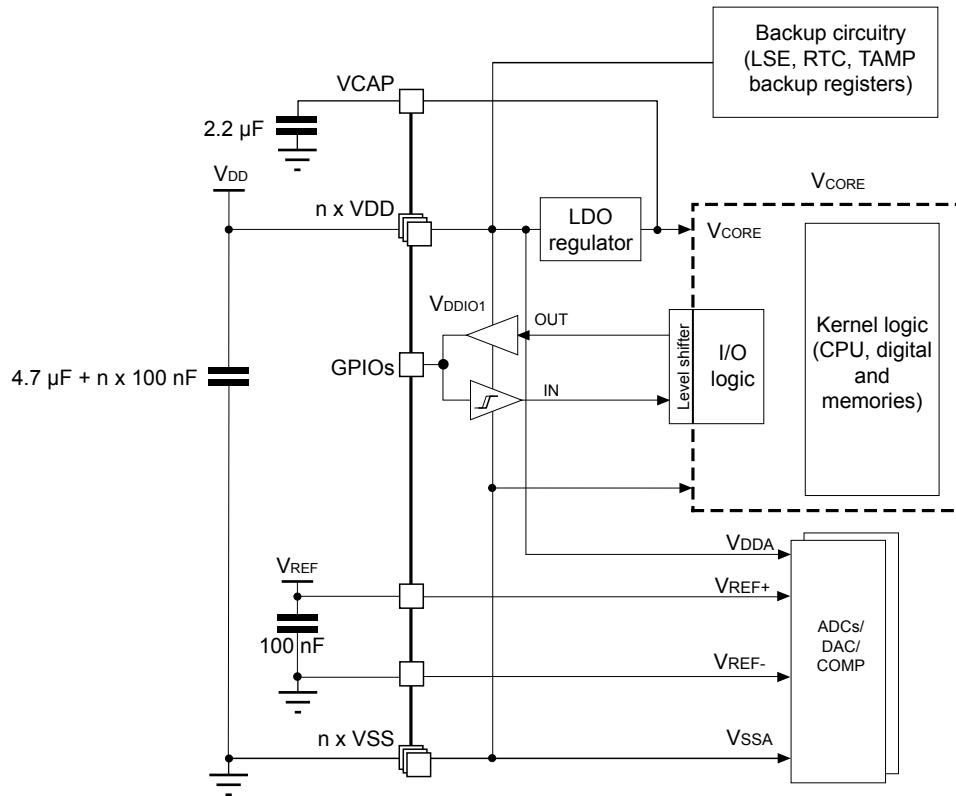

The external capacitor on VCAP pin requires the following characteristics:

- $C_{OUT} = 2.2 \mu\text{F}$
- $C_{OUT} \text{ ESR} < 20 \text{ m}\Omega$ at 3 MHz
- C_{OUT} rated voltage $\geq 10 \text{ V}$

5.2 Absolute maximum ratings

Stresses above the absolute maximum ratings listed in Table 15, Table 16, and Table 17 may damage permanently the device. These are stress ratings only and the functional operation of the device at these conditions is not implied. Exposure to maximum rating conditions for extended periods may affect device reliability. Device mission profile (application conditions) is compliant with JEDEC JESD47 qualification standard. Extended mission profiles are available on demand.

Table 15. Voltage characteristics

All main power (VDD) and ground (VSS) pins must always be connected to the external power supply, in the permitted range. The I/O structure options listed in this table can be a concatenation of options including the option explicitly listed. For instance, TT_a refers to any TT I/O with _a option. TT_xx refers to any TT I/O and FT_xx refers to any FT I/O.

Symbols	Ratings	Min	Max	Unit
$V_{DDX} - V_{SS}$	External main supply voltage (including V_{DD} , V_{DDA} and V_{REF+})	-0.3	4.0	V
$V_{IN}^{(1)}$	Input voltage on FT_xxx pins	$V_{SS} - 0.3$	MIN ($V_{DD} + 4.0V$, $6.0V$) ⁽²⁾	V
	Input voltage on TT_xx pins	$V_{SS} - 0.3$	4.0	V
$V_{REF+} - V_{DDA}$	Allowed voltage difference for $V_{REF+} > V_{DDA}$	-	0.4	V
$ \Delta V_{DDX} $	Variations between different VDDX power pins of the same domain	-	50.0	mV
$ V_{SSx} - V_{SS} $	Variations between all the different ground pins	-	50.0	mV

- V_{IN} maximum must always be respected. Refer to Table 16 for the maximum allowed injected current values.
- When the analog option is selected by enabling analog peripheral or the pull-up/pull-down resistors are enabled on a given pin, V_{IN} must not exceed 4 V.

Table 16. Current characteristics

Symbol	Ratings	Max	Unit
$\sum I_{VDD}$	Total current into sum of all V_{DD} power lines (source) ⁽¹⁾	200	mA
$\sum I_{VSS}$	Total current out of sum of all V_{SS} ground lines (sink) ⁽¹⁾	200	
I_{VDD}	Maximum current into each VDD power pin (source) ⁽¹⁾	100	
I_{VSS}	Maximum current out of each VSS ground pin (sink) ⁽¹⁾	100	
I_{IO}	Output current sunk by any I/O and control pin	20	
	Output current sourced by any I/O and control pin	20	
$\sum I_{(PIN)}$	Total output current sunk by sum of all I/Os and control pins ⁽²⁾	140	
	Total output current sourced by sum of all I/Os and control pins ⁽²⁾	140	
$I_{INJ(PIN)}^{(3)(4)}$	Injected current on FT_xx, TT_xx, RST pins	-5/0	
$\sum I_{INJ(PIN)}$	Total injected current (sum of all I/Os and control pins) ⁽⁵⁾	±25	

- All main power (V_{DD}) and ground (V_{SS}) pins must always be connected to the external power supplies, in the permitted range.
- This current consumption must be correctly distributed over all I/Os and control pins. The total output current must not be sunk/sourced between two consecutive power supply pins, referring to high pin count QFP packages.
- A negative injection is induced by $V_{IN} < V_{SS}$. $I_{INJ(PIN)}$ must never be exceeded. Refer also to Table 15 for the minimum allowed input voltage values.
- Positive injection (when $V_{IN} > V_{DDIOx}$) is not possible on these I/Os and does not occur for input voltages lower than the specified maximum value.
- When several inputs are submitted to a current injection, the maximum $\sum I_{INJ(PIN)}$ is the absolute sum of the negative injected currents (instantaneous values).

Table 17. Thermal characteristics

Symbol	Ratings	Value	Unit
T _{STG}	Storage temperature range	-65 to +150	°C
T _J	Maximum junction temperature	150	

5.3 Operating conditions

5.3.1 General operating conditions

Table 18. General operating conditions

Symbol	Parameter	Operating conditions	Min	Typ	Max	Unit
V _{DD} /V _{DDA}	Standard operating voltage	-	2.7 ⁽¹⁾	-	3.6	V
V _{IN}	I/O Input voltage	All I/O except TT_xx	V _{SS} -0.3	-	MIN (V _{DD} + 3.6V , 5.5 V) ⁽²⁾	
		TT_xx I/O	V _{SS} -0.3	-	V _{DD} + 0.3	
V _{CAP}	Internal regulator ON	RUN, SLEEP, STOP0 Modes	1.15	1.20	1.26	
		STOP1 Mode	0.9	0.95	1.0	
f _{HCLK}	AHB clock frequency	-	-	-	144	MHz
f _{PCLK}	APB clock frequency	-	-	-	144	
P _D	Power dissipation at T _A = 85 °C for suffix 6 ⁽³⁾	-	See Section 6.9: Package thermal characteristics for application appropriate thermal resistance and package. Power dissipation is then calculated according ambient temperature (T _A) and maximum junction temperature (T _J) and selected thermal resistance.			mW
	Power dissipation at T _A = 125 °C for suffix 3 Section 5.3.1: General operating conditions					
T _A	Ambient temperature for suffix 3 version	-	-40	-	125	°C
	Ambient temperature for suffix 6 version	-	-40	-	85	
T _J	Junction temperature range for suffix 3 version	-	-40	-	140	°C
	Junction temperature range for suffix 6 version.	-	-40	-	105	

1. When RESET is released, the functionality is guaranteed down to PDR minimum voltage.
2. For operation with voltage higher than V_{DD} + 0.3 V, the internal pull-up and pull-down resistors must be disabled. The minimum and maximum input voltage (V_{in}) must comply with the selected peripheral enabled on the given GPIOs. Refer to the respective peripheral characteristics for details.
3. If T_A is lower, higher P_D values are allowed as long as T_J does not exceed T_Jmax (see Section 6.9: Package thermal characteristics).

5.3.2 Operating conditions at power-up/power-down

The parameters given in the table below are derived from tests performed under the ambient temperature condition summarized in Table 18.

Table 19. Operating conditions at power-up/power-down

Symbol	Parameter	Min	Max	Unit
t _{VDD}	V _{DD} rise-time rate	0	∞	μs/V
	V _{DD} fall-time rate	0	∞	ms/V

5.3.3 Embedded reset and power control block characteristics

The parameters given in the table below are derived from tests performed under the ambient temperature conditions summarized in Table 18.

Table 20. Embedded reset and power control block characteristics

The values in this table are evaluated by characterization - Not tested in production, unless otherwise specified.

Symbol	Parameter	Conditions	Min	Typ	Max	Unit
t _{RSTTEMPO} ⁽¹⁾⁽²⁾	Reset temporization after POR released	V _{DD} rising	-	-	463	μs
V _{POR/PDR}	Power-on/power-down reset threshold (BORH_EN =0)	Rising edge	2.56	2.61	2.64	V
		Falling edge	2.53	2.58	2.61	
V _{PVD}	Programmable Voltage Detector threshold	Rising edge	3.00	3.04	3.08	V
		Falling edge	2.89	2.93	2.96	
V _{hyst_POR_PDR}	Hysteresis for power-on/power-down reset	-	-	30	-	mV
V _{hyst_PVD}	Hysteresis voltage of PVD	-	-	110	-	
I _{DD_PVD} ⁽²⁾	PVD consumption from VDD	-	-	-	0.63	μA

1. Specified by design - Not tested in production.
2. From POR threshold crossing to NRST pull-up resistor activation.

5.3.4 Inrush current and inrush electric charge characteristics

The parameters provided in the following table are specified by design simulation and are not tested in production.

Table 21. Embedded internal voltage reference

The typical values are provided for V_{DD} = 3.3V and for a typical decoupling capacitor value .

The product consumption on V_{DDCORE} is not included in the inrush current and inrush electric charge

Symbol	Parameter	Typ	Unit
I _{RUSH}	Inrush current during voltage regulator power-on (POR) or wake-up from standby	35	mA
Q _{RUSH}	Inrush electric charge during voltage regulator power-on (POR) or wake-up from standby.	2.8	μC

5.3.5 Embedded voltage reference

The parameters provided in Table 22. Embedded internal voltage reference are derived from tests performed under the ambient temperature and supply voltage conditions summarized in Section 5.3.1.

Table 22. Embedded internal voltage reference

The values in this table are specified by design and not tested in production.

Symbol	Parameter	Conditions	Min	Typ	Max	Unit
V _{REFINT}	Internal reference voltages	-40°C < T _J < 140 °C	1.180	1.217	1.250	V
t _{S_vrefint} ⁽¹⁾⁽²⁾	ADC sampling time when reading the internal reference voltage	-	4.3	-	-	µs
t _{S_vbat} ⁽¹⁾	VBAT sampling time when reading the internal VBAT reference voltage	-	9	-	-	µs
t _{start_vrefint} ⁽²⁾	Start time of reference voltage buffer when ADC is enable	-	-	-	4.4	µs
I _{refbuf} ⁽²⁾	Reference Buffer consumption for ADC	V _{DDA} = 3.3 V	9	13.5	23	µA
ΔV _{REFINT} ⁽²⁾	Internal reference voltage spread over the temperature range	-40 °C < T _J < 140 °C	-	5	15	mV
T _{coeff}	Average temperature coefficient	Average temperature coefficient	-	19	67	ppm/°C
V _{DDcoeff}	Average Voltage coefficient	3.0 V < V _{DD} < 3.6 V	-	10	1370	ppm/V

1. The shortest sampling time for the application can be determined by multiple iterations.
2. Specified by design - Not tested in production.

Table 23. Internal reference voltage calibration values

Symbol	Parameter	Memory address
V _{REFINT_CAL}	Raw data acquired at temperature of 30 °C, V _{DDA} = 3.3 V	0x08FFF810 - 0x08FFF812

5.3.6 Supply current characteristics

The current consumption is a function of several parameters and factors such as the operating voltage, ambient temperature, I/O pin loading, device software configuration, operating frequencies, I/O pin switching rate, program location in memory and executed binary code.

The current consumption is measured as described in Current consumption measurement.

Typical and maximum current consumption

The MCU is placed under the following conditions:

- All I/O pins are in analog input mode.
- All peripherals are disabled except when explicitly mentioned.
- The flash memory access time is adjusted with the minimum wait-state number, depending on the f_{HCLK} frequency (refer to the tables *Number of wait states according to CPU clock (HCLK) frequency* available in the product reference manual).
- When the peripherals are enabled, f_{PCLK} = f_{HCLK}.

The parameters given in the tables below are derived from tests performed under ambient temperature and supply voltage conditions summarized in Section 5.3.1: General operating conditions. If not specified otherwise, typical data are measured with a V_{DD} supply of 3.0 V, and maximum data are measured at 3.6 V.

5.3.6.1 Current consumption in Run mode
Table 24. Typical and maximum current consumption in Run mode

Specified by design - not tested in production, unless otherwise stated.
 Clocked by HSI at 144 MHz of HSIDIV3 at 48MHz if not otherwise specified.

Symbol	Parameter	Conditions	f _{HCLK} (MHz)	Typ	Max LDO		Unit
					T _J = 30°C	T _J = 140°C	
I _{DD(Run)} ⁽¹⁾	Supply current in Run mode with all peripheral clocks disabled	Code in Flash, ICACHE 2-way	144	11.4	12.00	24.00	mA
			48	4.1	4.20	17.50	
		Code in Flash, ICACHE 1-way	144	10.5	11.00	23.00	
			48	3.8	4.00	17.50	
		Code in Flash, ICACHE OFF	144	11.3	12.00	23.50	
			48	4.6	5.00	18.00	
	Supply current in Run mode with all peripheral clocks enabled	Code in SRAM2, ICACHE OFF, FLASH ON	144	10.5	11.00	23.50	
			48	3.8	4.00	17.50	
		Code in flash, ICACHE 2-way	144 ⁽²⁾	27.0	35.00	47.00	
		Code in flash, ICACHE OFF	144 ⁽²⁾	27.0	35.00	47.00	

1. Measurements done with prefetch enabled.
2. Clocked by PSI at 144 MHz with HSE at 16 MHz in bypass mode.

Table 25. Typical current consumption in Run mode with CoreMark running from flash memory and SRAM

Specified by design - not tested in production, unless otherwise stated.

Symbol	Parameter	Conditions	SYSCLK source	(MHz)	Typ	Unit	Typ	Unit
		Peripheral						
I _{DD(Run)} ⁽¹⁾	Supply current in Run mode	All peripherals disabled, Instruction cache 2-WAY, Prefetch ON	PSI ⁽²⁾	144	11.00	mA	69.50	μA/ MHz
		All peripherals disabled, Instruction cache 1-WAY, Prefetch ON						
		All peripherals disabled, Instruction cache OFF, Prefetch ON						
		All peripherals disabled, Instruction cache OFF, Prefetch OFF						
		All peripherals disabled, SRAM2, Instruction cache 2-WAY, FLASH ON						
		All peripherals disabled, SRAM2, Instruction cache 1-WAY, FLASH ON						
		All peripherals disabled, SRAM2, Instruction cache OFF, FLASH ON						

1. Measures done with prefetch enabled.
2. Clocked by PSI 144 MHz with HSE at 16 MHz on bypass mode.

5.3.6.2 Current consumption in Sleep mode
Table 26. Typical and maximum current consumption in Sleep mode

Specified by design - not tested in production, unless otherwise stated.

Symbol	Parameter	Conditions	(MHz)	Typ	Max		Unit
					T _J = 30°C	T _J = 140°C	
I _{DD(SLEEP)}	Supply current in Sleep mode	All peripherals disabled, HSI	HSI 144	2.40	2.55	20.00	mA
			HSI 48	1.05	1.25	16.50	
		All peripherals enabled, HSI	HSI 144	19.50	21.00	34.00	
			HSI 48	6.90	7.10	22.00	

5.3.6.3 Current consumption in Stop mode
Table 27. Typical and maximum current consumption in Stop mode

Specified by design - not tested in production, unless otherwise stated.

Symbol	Parameter	Conditions	Typ	Max		Unit	
				T _J = 30°C	T _J = 140°C		
I _{DD(STOP)}	FLASH ON	SRAM1/2 ON	STOP0	0.22	0.36	14.00	mA
			STOP1	0.07	0.15	9.00	
	FLASH IN LOW POWER	SRAM1/2 ON	STOP0	0.20	0.35	13.00	
			STOP1	0.06	0.13	8.60	
		SRAM1/2 OFF	STOP0	0.19	0.35	12.00	
			STOP1	0.06	0.12	8.75	

Table 28. Typical and maximum HSIKERON current consumption in Stop mode

Specified by design - not tested in production, unless otherwise stated.

Symbol	Parameter	Conditions	Typ	Max		Unit
				T _J = 30°C	T _J = 140°C	
I _{DD(Stop)}	FLASH IN LOW POWER	HSIKERON, STOP0	HSI144	0.51	0.65	12.00
			HSI48	0.40	0.55	12.00

5.3.6.4 Current consumption in Standby mode
Table 29. Typical and maximum current consumption in Standby mode

Specify by design - not tested in production, unless otherwise stated.

Symbol	Parameter	RTC and LSE ⁽¹⁾	Typ			Max		Unit
			2.7 V	3 V	3.3 V	T _J = 30°C	T _J = 140°C	
I _{DD(Standby)}	Supply current in Standby mode, IWDG OFF	OFF	2.75	2.90	3.00	4.00	105.00	μA
		ON	3.10	3.25	3.40	-	-	
	Supply current in Standby mode, IWDG ON	OFF	3.10	3.25	3.40	5.25	105.00	
		ON	3.40	3.55	3.75	-	-	

1. LSE is in low drive mode.

5.3.6.5 Current consumption from peripherals
Table 30. Peripheral current consumption measured in Sleep mode

Bus	Peripheral	I _{DD} (Typ)	Unit
AHB1	CORDIC	1.35	μA/MHz
	CRC	1.3	
	ETH	13.6	
	FLASH	7.1	
	ICACHE1	0.495	
	LPDMA1	2.15	
	LPDMA2	2.25	
	RAMCFG	1.6	
	SRAM1	0.305	
	SRAM2	0.86	
AHB2	ADC12	5.6	
	ADC3	3.25	
	AES	1.2	
	CCB	0.8	
	DAC1	0.54	
	GPIOA	0.215	
	GPIOB	0.085	
	GPIOC	0.099	
	GIOD	0.078	
	GPIOE	0.098	
	GPIOF	0.085	
	GPIOH	0.099	
	HASH	1.2	
	PKA	0.165	
	RNG	1.4	
	SAES	47.6	
	XSPI1	2.85	
APB1	COMP1	0.195	
	COMP12	0.002	
	CRS	0.205	
	FDCAN	9.4	
	I2C1	1.95	
	I2C2	2	
	I3C1	0.315	
	SPI2	1.55	
	SPI3	1.45	
	TIM12	0.27	
TIM2	0.28		

Bus	Peripheral	I _{DD} (Typ)	Unit
APB1	TIM3	0.295	μA/MHz
	TIM4	0.275	
	TIM5	0.305	
	TIM6	0.26	
	TIM7	0.27	
	UART4	3.3	
	UART5	3.55	
	UART7	4.05	
	USART2	4	
	USART3	3.95	
	USART6	1.3	
	WWDG	0.14	
APB2	SPI1	1.75	
	TIM1	0.32	
	TIM15	0.275	
	TIM16	0.28	
	TIM17	0.295	
	TIM8	0.325	
	USART1	3.55	
	USB_DRD_FS	1.95	
APB3	LPTIM1	0.83	
	LPUART1	2.75	
	SBS	0.335	

5.3.7 Wake-up time from low-power modes and voltage scaling transition times

The wake-up times given in the table below are the latency between the event and the execution of the first user instruction.

The device goes in low-power mode after the WFE (wait for event) instruction

Table 31. Wake-up time from low-power modes

1. Evaluated by characterization - Not tested in production.
2. The wakeup times are measured from the wakeup event to the point in which the application code reads the first instruction.

Symbol	Parameter	Conditions	Wakeup clock	f _{HCLK} (MHz)	Typ	Unit
t _{wu(Sleep)}	Wakeup from Sleep	Instruction cache enabled or disabled	-	-	16	CPU clock cycles
t _{wu(Stop)}	Wakeup from Stop 0	Flash memory in normal mode	HSI	144	3.6	μs
		Flash memory in low-power mode	HSI	144	7.3	
		Flash memory in normal mode	HSIDIV3	48	5.4	
		Flash memory in low-power mode	HSIDIV3	48	9.0	
	Wakeup from Stop 1 ⁽¹⁾	Flash memory in normal mode	HSI	144	36.0	
		Flash memory in low-power mode	HSI	144	39.8	
		Flash memory in normal mode	HSIDIV3	48	39.0	
		Flash memory in low-power mode	HSIDIV3	48	37.9	
t _{wu(Standby)} ⁽²⁾	Wakeup from Standby mode ⁽¹⁾	-	HSIDIV3	48	445	

1. Those parameters depend on V_{CAP} capacitance value and V_{CAP} voltage at the instant of the wake-up event.
2. Those parameters depend on VCAP capacitance value and VCAP voltage at the instant of the wake-up event.

Table 32. Wake-up time using USART/LPUART

Symbol	Parameter	Condition	Typ	Max ⁽¹⁾	Unit
t _{wuUSART/} t _{wuLPUART}	Wake-up time needed to calculate the maximum USART/LPUART baudrate allowing to wake up from Stop mode when USART/LPUART clock source is 48 MHz by HSIDIV3	Stop 0 mode Stop 1 mode	4.8	6.6	μs

1. Specified by design - Not tested in production.

5.3.8 External clock timing characteristics

5.3.8.1 High-speed external user clock generated from an external source

In bypass mode, the HSE oscillator is switched off and the input pin is a standard GPIO.

The external clock signal has to respect the I/O characteristics in I/O port characteristics. However, the recommended clock input waveform is shown in the figure below.

Table 33. High-speed external user clock characteristics

Specified by design and not tested in production.

Symbol	Parameter	Conditions	Min	Typ	Max	Unit
f _{HSE_ext}	User external clock source frequency	Digital mode (HSEYBYP = 1, HSEEXT = 1)	-	-	50	MHz
		Analog mode (HSEYBYP = 1, HSEEXT = 0)	4	-	50	
V _{HSEH}	OSC_IN input pin high-level voltage	Digital mode (HSEYBYP = 1, HSEEXT = 1)	0.7 × V _{DD}	-	V _{DD}	V

Symbol	Parameter	Conditions	Min	Typ	Max	Unit
V_{HSEL}	OSC_IN input pin low-level voltage	Digital mode (HSEYBYP = 1, HSEEXT = 1)	V_{SS}	-	$0.3 \times V_{DD}$	V
$t_{w(HSEH)}$ $t_{w(HSEL)}$	OSC_IN high or low time	Digital mode (HSEYBYP = 1, HSEEXT = 1)	7	-	-	ns
$DuCy_{HSE}$	OSC_IN duty cycle	Digital mode (HSEYBYP = 1, HSEEXT = 1)	45	-	55	%
$V_{HSE_ext_PP}$	OSC_IN peak-to-peak amplitude	Analog mode (HSEYBYP = 1, HSEEXT = 0)	0.2	-	$2/3 V_{DD}$	V
V_{HSE_ext}	OSC_IN input range		0	-	V_{DD}	
$t_{r(HSE)}$, $t_{f(HSE)}$	OSC_IN rise and fall time		$0.05 / f_{ext_ext}$	-	$0.3 / f_{ext_ext}$	ns

1. There is no specified rise and fall time for a digital input signal, but the V_{HSEH} and V_{HSEL} conditions must be fulfilled.
2. The DC component of the signal must ensure that the signal peaks are located between V_{DD} and V_{SS} .

Figure 14. AC timing diagram for high-speed external clock source (digital mode)

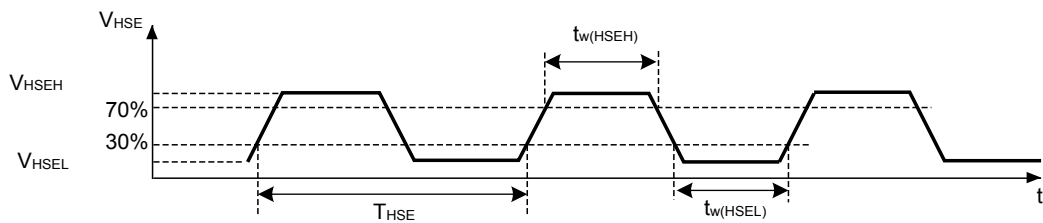

DT67850V3

Figure 15. AC timing diagram for high-speed external clock source (analog mode)

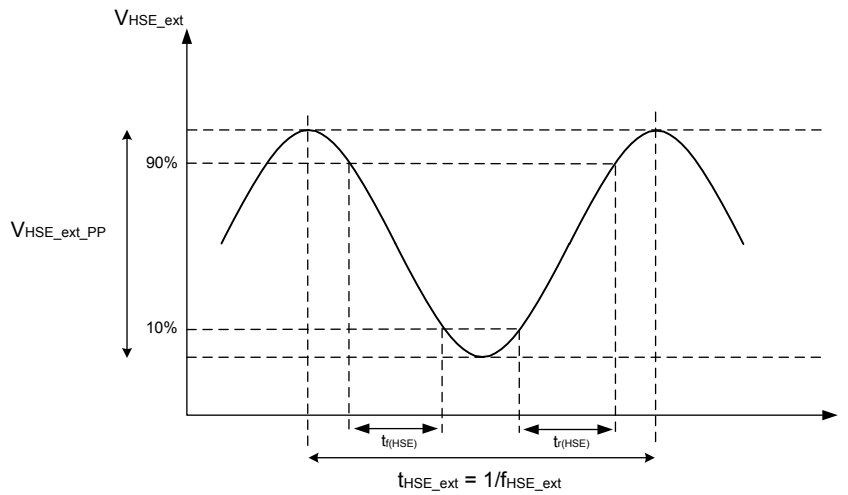

DT71538V1

5.3.8.2 Low-speed external user clock generated from an external source

In bypass mode, the LSE oscillator is switched off and the input pin is directly connected to the LSE clock detector (LSECSS). The external clock signal has to respect the parameters specified in Table 34, as shown also by the waveforms in Figure 16.

Table 34. Low-speed external user clock characteristics

Specified by design and not tested in production.

Symbol	Parameter	Conditions	Min	Typ	Max	Unit
f_{LSE_ext}	User external clock source frequency	External digital/analog clock	-	32.768	1000	kHz
V_{LSEH}	Digital OSC_IN input high level	External digital clock	$0.7 V_{DD}$	-	V_{DD}	V
V_{LSEL}	OSC32_IN input pin low level voltage	External digital clock	V_{SS}	-	$0.3 V_{DD}$	
$t_{w(LSEH)}/t_{w(LSEL)}$	OSC32_IN high or low time	External digital clock	250	-	-	ns
V_{ISW_H}	Analog low swing OSC_IN high level	External analog low swing clock	0.6	-	1.225	V
V_{ISW_L}	Analog low swing OSC_IN low level	External analog low swing clock	0.35	-	0.8	
$V_{ISWLSE} (V_{LSEH} - V_{LSEL})$	Analog low swing OSC_IN peak-to-peak amplitude	External analog low swing clock	0.2	-	0.875	
$DuCy_{LSE}$	Analog low swing OSC_IN duty cycle	External analog Low Swing Clock	45	50	55	%
t_{rLSE}/t_{fLSE}	Analog low swing OSC_IN rise and fall time	External analog low swing clock 10 % to 90 %	-	100	200	ns

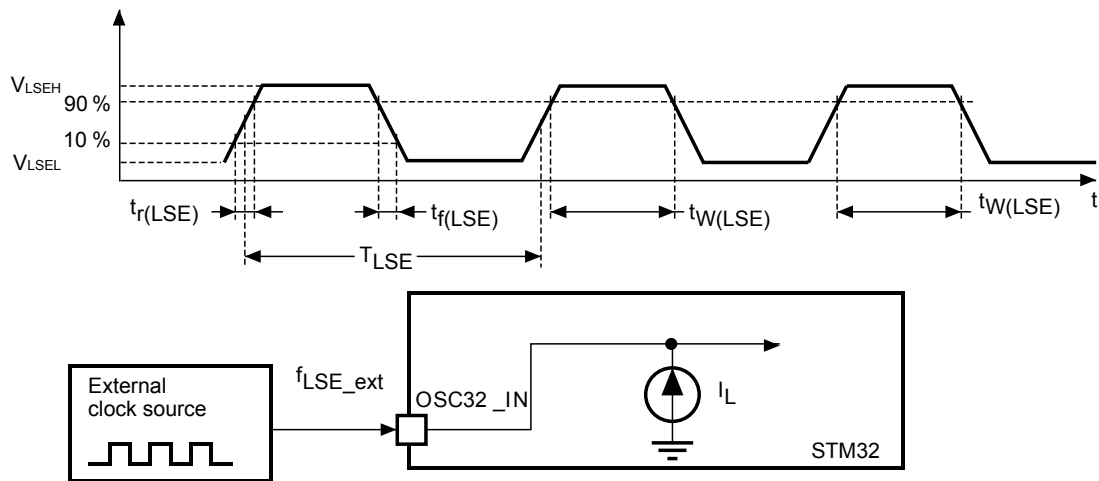
Figure 16. Low-speed external clock source AC timing diagram

DT17529V1

5.3.8.3 High-speed external clock generated from a crystal/ceramic resonator

The high-speed external (HSE) clock can be supplied with a 4 to 48 MHz crystal/ceramic resonator oscillator. All the information given in this paragraph are based on design simulation results obtained with typical external components specified in the table below.

In the application, the resonator and the load capacitors have to be placed as close as possible to the oscillator pins, in order to minimize the output distortion and startup stabilization time. Refer to the crystal resonator manufacturer for more details on the resonator characteristics (frequency, package, accuracy).

Table 35. 4-50 MHz HSE oscillator characteristics

Specified by design and not tested in production.

Symbol	Parameter	Operating conditions ⁽¹⁾	Min	Typ	Max	Unit
F	Oscillator frequency	-	4	-	50	MHz
RF	Feedback resistor	-	-	200	-	kΩ
I _{DD(HSE)}	HSE current consumption	During startup ⁽²⁾	-	-	10	mA
		V _{DD} = 3 V, R _m = 20 Ω C _L = 10 pF at 4 MHz	-	0.4	-	
		V _{DD} = 3 V, R _m = 20 Ω C _L = 10 pF at 8 MHz	-	0.4	-	
		V _{DD} = 3 V, R _m = 20 Ω C _L = 10 pF at 16 MHz	-	0.6	-	
		V _{DD} = 3 V, R _m = 20 Ω C _L = 10 pF at 32 MHz	-	0.7	-	
G _{mcritmax}	Maximum critical crystal gm	Startup	-	-	1.5	mA/V
		V _{DD} = 3 V, R _m = 20 Ω C _L = 10 pF at 48 MHz	-	1.2	-	
t _{SU} ⁽³⁾	Start-up time	V _{DD} is stabilized	-	2	-	ms

1. Resonator characteristics given by the crystal/ceramic resonator manufacturer.
2. This consumption level occurs during the first 2/3 of the t_{SU(HSE)} startup time.
3. t_{SU(HSE)} is the startup time measured from the moment it is enabled (by software) to a stabilized 8 MHz oscillation is reached. This value is measured for a standard crystal resonator and it can vary significantly with the crystal manufacturer.

Note: For information on selecting the crystal, refer to the application note 'Oscillator design guide for STM8AF/AL/S, STM32 MCUs and MPUs' (AN2867).

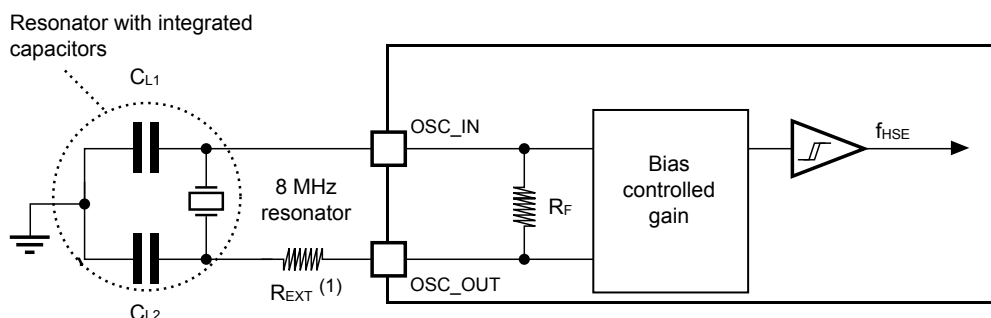
Figure 17. Typical application with a 8 MHz crystal

(1): R_{EXT} value depends on the crystal characteristics.

DT19876V1

5.3.8.4 Low-speed external clock generated from a crystal resonator

The low-speed external (LSE) clock can be supplied with a 32.768 kHz crystal resonator oscillator. All the information given in this paragraph are based on design simulation results obtained with typical external components specified in the table below. In the application, the resonator and the load capacitors have to be placed as close as possible to the oscillator pins in order to minimize output distortion and startup stabilization time. Refer to the crystal resonator manufacturer for more details on the resonator characteristics (frequency, package, accuracy).

Table 36. LSE oscillator characteristics ($f_{LSE} = 32.768 \text{ kHz}$)

Specified by design and not tested in production.

Symbol	Parameter	Operating conditions ⁽¹⁾	Min	Typ	Max	Unit
F	Oscillator frequency	-	-	32.768	-	kHz
I_{DD}	LSE current consumption	LSEDRV[1:0] = 00, Low drive capability	-	246	-	nA
		LSEDRV[1:0] = 01, Medium low drive capability	-	333	-	
		LSEDRV[1:0] = 10, Medium high drive capability	-	462	-	
		LSEDRV[1:0] = 11, High drive capability	-	747	-	
Gm _{critmax}	Maximum critical crystal Gm	LSEDRV[1:0] = 00, Low drive capability	-	-	0.5	$\mu\text{A/V}$
		LSEDRV[1:0] = 01, Medium low drive capability	-	-	0.75	
		LSEDRV[1:0] = 10, Medium high drive capability	-	-	1.7	
		LSEDRV[1:0] = 11, High drive capability	-	-	2.7	
$t_{SU}^{(2)}$	Startup time	V_{DD} is stabilized	-	2	-	s

1. Refer to the following note and caution paragraphs, and to the application note AN2867 "Oscillator design guide for ST microcontrollers.
2. t_{SU} is the startup time measured from the moment it is enabled (by software) to a stabilized 32.768k Hz oscillation is reached. This value is measured for a standard crystal resonator and it can vary significantly with the crystal manufacturer.

Note: For information on selecting the crystal, refer to the application note 'Oscillator design guide for STM8AF/AL/S, STM32 MCUs and MPUs' (AN2867).

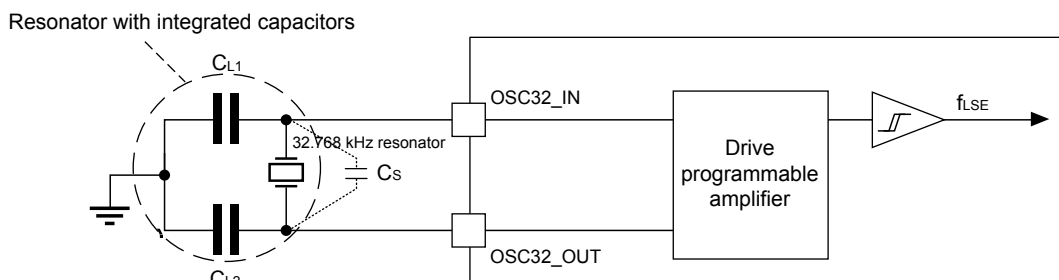
Figure 18. Typical application with a 32.768 kHz crystal

Note: CL1 and CL2 are external load capacitances. Cs (stray capacitance) is the sum of the device OSC32_IN/OSC32_OUT pins equivalent parasitic capacitance (C_{S_PARA}), and the PCB parasitic capacitance.

Note: An external resistor is not required between OSC32_IN and OSC32_OUT and it is forbidden to add one.

DT70418V1

5.3.9 Internal clock timing characteristics

The parameters given in the tables below are derived from tests performed under ambient temperature and supply voltage conditions summarized in Table 18. The curves provided are characterization results, not tested in production.

5.3.9.1 High-speed internal HSI144 oscillator

Table 37. HSI144 oscillator characteristics

Symbol	Parameter	Conditions	Min	Typ	Max	Unit
$f_{\text{HSI}}^{(1)}$	HSI frequency	$V_{\text{DD}} = 3.3 \text{ V}$, $T_{\text{J}} = 30 \text{ }^{\circ}\text{C}$	144.07	-	145.08	MHz
TRIM ⁽²⁾	USER trimming step	-	-	0.1	0.15	
USER TRIM COVERAGE ⁽²⁾	USER TRIMMING Coverage positive	80 steps	5.2%	8%	-	
	USER TRIMMING Coverage negative	48 steps	-3.1%	-4.8%	-	
DuCy(HSI) ⁽²⁾	Duty Cycle	-	45		55	%
$\Delta_{\text{TEMP}}(\text{HSI})^{(3)}$	HSI oscillator frequency drift over temperature (the reference is 144 MHz.)	$T_{\text{J}} = -20 \text{ to } 130 \text{ }^{\circ}\text{C}$	-1	-	1	
		$T_{\text{J}} = -40 \text{ to } T_{\text{Jmax}} \text{ }^{\circ}\text{C}$	-1.5	-	1.5	
$\Delta_{\text{VDD}}(\text{HSI})^{(2)(4)}$	HSI oscillator frequency drift with V_{DD} Section 5.3.9.1: High-speed internal HSI144 oscillator ⁽⁵⁾ (the reference is 3.3V)	V_{DD} from 2.7 V to 3.6 V	-	-	-0.1	
$t_{\text{su}}(\text{HSI})^{(3)}$	HSI oscillator start-up time (PSI Off)	-	-	3	4.5	μs
	HSI oscillator start-up time (PSI On)	-	-	0.5	-	
$t_{\text{stab}}^{(2)}$	stabilization time (PSI OFF from Enable)	+/-1% of target freq	-	-	8	μs
	stabilization time (PSI ON from Enable)		-	-	0.7	
$I_{\text{DD}}(\text{HSI})^{(2)(6)}$	HSI supply regulation block oscillator power consumption	-	-	91	-	μA
	HSI oscillator power consumption	-	-	28	-	
$N_{\text{T}} \text{ jitter}^{(2)}$	Next transition jitter ⁽⁷⁾ .	On HSIDIV3	-	52	322	ps
$P_{\text{T}} \text{ jitter}^{(2)}$	Paired transition jitter ⁽⁸⁾		-	62	394	
$P_{\text{er}} \text{ jitter}^{(2)}$	Period Jitter standard deviation	On HSIS		15		
		On HSIDIV3		26		

1. Tested in production.
2. Specified by design - Not tested in production.
3. Evaluated by characterization - Not tested in production.
4. $\Delta f_{\text{HSI}} = \Delta_{\text{TEMP}} + \Delta_{\text{VDD}}$
5. These values are obtained by using formula: $(\text{Freq}(3.6 \text{ V}) - \text{Freq}(3.3 \text{ V})) / \text{Freq}(3.3 \text{ V})$ or $(\text{Freq}(3.6 \text{ V}) - \text{Freq}(2.7 \text{ V})) / \text{Freq}(2.7 \text{ V})$.
6. The supply regulation consumption is common to HSI and PSI. (To be counted once if both oscillators are ON).
7. Jitter measurements are performed without clock source activated in parallel. Typical value is standard deviation, Maximum is peak measure on TIE-8 over 36 cycles.
8. Jitter measurements are performed without clock source activated in parallel. Typical value is standard deviation, Maximum is peak measure on TIE-16 over 36 cycles.

Figure 19. HSI frequency versus temperature

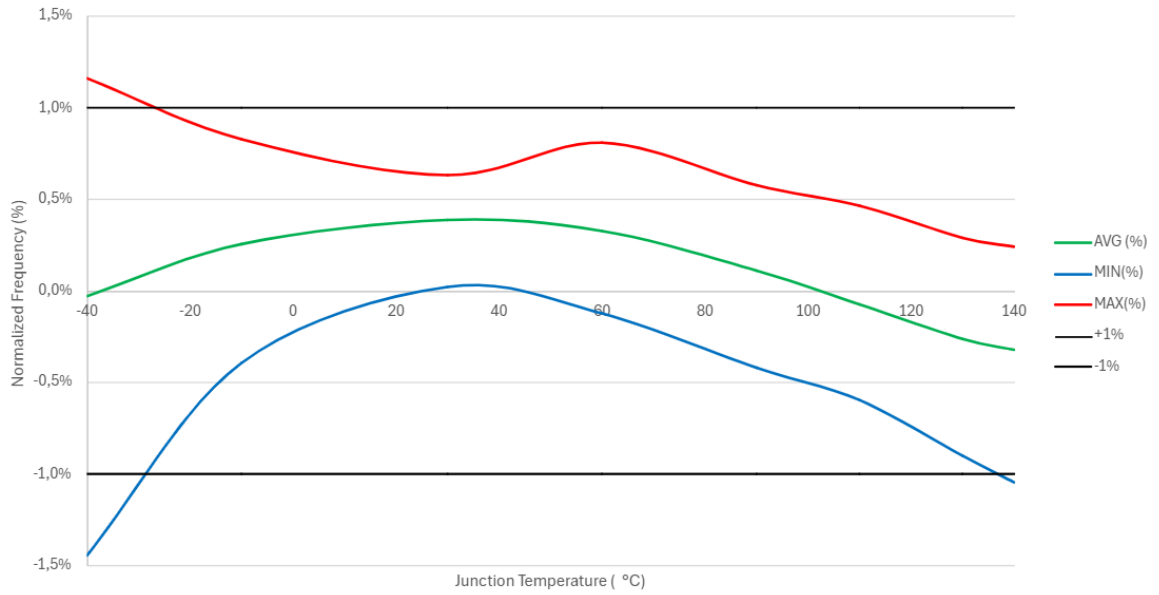

DT76154V2

5.3.9.2 PSI oscillator characteristics
Table 38. PSI oscillator characteristics

Symbol	Parameter	Conditions	Min ⁽¹⁾	Typ	Max	Unit
f _{PSI}	PSI potential frequency	If reference is HSE at 8, 16, 24, 32 or 48 MHz or HSDIV18	-	100	-	MHz
			-	144	-	
			-	160 ⁽²⁾	-	
		If reference is HSE at 25 or 50 MHz	-	100	-	
			-	141.67	-	
			-	158.33 ⁽²⁾	-	
		If reference is LSE at 32 KHz	-	100.008	-	
			-	144.015	-	
-	-	160.006 ⁽²⁾	-			
DuCy(PSI) ⁽³⁾	Duty Cycle	-	45		55	%
t _{su(PSI)} ⁽⁴⁾	PSI startup time	On 32 KHz	-	850	1750	µs
	PSI startup time	On 8 MHz	-	25	45	µs
I _{DD(PSI)} ⁽⁵⁾	PSI supply regulation bloc oscillator power consumption	If HSI not ON	-	91	-	µA
	PSI oscillator power consumption	100 MHz	-	95	-	
	PSI oscillator power consumption	144 MHz	-	68	-	
	PSI oscillator power consumption	160 MHz	-	77	-	
N _T jitter ⁽³⁾	Next transition jitter ⁽⁶⁾	On PSIDIV3 (48 MHz with 32 kHz CK_IN)	-	46.8	264	ps
		On PSIDIV3 (48 MHz with 8 MHz CK_IN)	-	52.6	276	ps
P _T jitter ⁽³⁾	Paired transition jitter ⁽⁷⁾	On PSIDIV3 (48 MHz with 32 kHz CK_IN)	-	54.4	331	ps
		On PSIDIV3 (48 MHz with 8 MHz CK_IN)	-	60.6	367	ps
P _{er} jitter ⁽³⁾	Period Jitter standard deviation	On PSIS (100 MHz)	-	15.5	-	ps
		On PSIDIV3 (33.33 MHz)	-	27	-	ps
		On PSIS (144 MHz)	-	14	-	ps
		On PSIDIV3 (48 MHz)	-	24.5	-	ps
		On PSIS (160 MHz)	-	13.5	-	ps
		On PSIDIV3 (53.33 MHz)	-	23	-	ps
LT jitter ⁽³⁾	Long term jitter ethernet	On PSIS (100 MHz with 32 kHz CK_IN)	-	-	13.7 (RMS) 96.7 (peak)	ns
		On PSIS	-	-	0.79 (RMS)	ns

Symbol	Parameter	Conditions	Min ⁽¹⁾	Typ	Max	Unit
LT jitter ⁽³⁾	Long term jitter ethernet	(100 MHz with 8 MHz CK_IN)			6.69 (peak)	
	Long term jitter FDCAN	On PSIK (40 MHz with 32 kHz CK_IN)	-	-	13.3 (RMS) 83.6 (peak)	ns
		On PSIK (40 MHz with 8 MHz CK_IN)	-	-	0.775 (RMS) 6.16 (peak)	ns

1. *Tested in production.*
2. *Frequencies above the supported product's maximum frequency can only be used once divided through PSIK or PSIDIV4 dividers.*
3. *Specified by design - Not tested in production.*
4. *Evaluated by characterization - Not tested in production.*
5. *The supply regulation consumption is common to HSI and PSI. (To be counted once if both oscillators are ON)*
6. *Jitter measurements are performed without clock source activated in parallel. The typical value refer to the standard deviation, while the maximum is the peak measurement of TIE-8 over 36 cycles.*
7. *Jitter measurements are performed without clock source activated in parallel. The typical value refer to the standard deviation, while the maximum is the peak measurement of TIE-16 over 36 cycles.*

5.3.9.3 Low-speed internal (LSI) RC oscillator
Table 39. LSI oscillator characteristics

Symbol	Parameter	Conditions	Min	Typ	Max	Unit
f_{LSI}	LSI frequency	$V_{DD} = 3.3\text{ V}, T_J = 30^\circ\text{C}$	31.4 ⁽¹⁾	32	32.6 ⁽¹⁾	kHz
		$T_J = -40\text{ to }130^\circ\text{C}$	29.4 ⁽²⁾		33.6 ⁽²⁾	
		$T_J = -40\text{ to }140^\circ\text{C}$	28.6 ⁽²⁾	-	33.6 ⁽²⁾	
$t_{su(LSI)}^{(3)}$	LSI oscillator startup time	-	-	80	130	μs
$t_{stab(LSI)}^{(3)}$	LSI oscillator stabilization time (5% of final value)	-	-	120	170	
$I_{DD(LSI)}^{(3)}$	LSI oscillator power consumption	-	-	130	280	nA

1. Guaranteed by test production.
2. Evaluated by characterization - Not tested in production.
3. Specified by design - Not tested in production.

5.3.10 Flash memory characteristics
Table 40. Flash memory characteristics

Specified by design and not tested in production.

Symbol	Parameter	Conditions	Min	Typ	Max	Unit
I_{DD}	Supply current	Word program	-	1	-	mA
		Page erase	-	0.8	-	
		Mass erase	-	0.8	-	

Table 41. Flash memory programming

Symbol	Parameter	Conditions	Min ⁽¹⁾	Typ	Max ⁽¹⁾	Unit
t_{prog}	Word programming time	128 bits (user area)	-	20.0	160.0	μs
		16 bits (OTP / EDATA area)	-	20.0	160.0	
$t_{ERASE\ 8KB}$	Page (8 KB) erase time	-	-	2.0	2.1	ms
$t_{ERASE\ 2KB}$	Page (2 KB) erase time	-	-	2.0	2.1	
t_{ME}	Bank Mass erase time	-	-	160.0	168.0	
	Mass erase time	-	-	320.0	336.0	
V_{prog}	Programming voltage	-	2.65	-	3.6	V

1. Evaluated by characterization - Not tested in production.

Table 42. Flash memory user and EDATA endurance and data retention

Symbol	Parameter	Conditions	Min ⁽¹⁾	Unit
N_{END}	Endurance	$T_J = -40\text{ to }140^\circ\text{C}$	10	Kcycle
t_{RET}	Data retention	1 Kcycle at $T_J = 125^\circ\text{C}$	10	Year
		1 Kcycle at $T_J = 85^\circ\text{C}$	30	
		10 Kcycle at $T_J = 55^\circ\text{C}$	30	

1. Evaluated by characterization - Not tested in production.

5.3.11 EMC characteristics

Susceptibility tests are performed on a sample basis during device characterization.

Functional EMS (electromagnetic susceptibility)

While a simple application is executed on the device (toggling two LEDs through the I/O ports), the device is stressed by two electromagnetic events until a failure occurs. The failure is indicated by the LEDs as follows:

- Electrostatic discharge (ESD) (positive and negative): applied to all device pins until a functional disturbance occurs. This test is compliant with the IEC 61000-4-2 standard.
- FTB (fast transient voltage burst) (positive and negative): applied to VDD and VSS pins through a 100 pF capacitor, until a functional disturbance occurs. This test is compliant with the IEC 61000-4-4 standard.

A device reset allows normal operations to be resumed.

The test results are given in the table below. They are based on the EMS levels and classes defined in application note *EMC design guide for STM8, STM32 and Legacy MCUs (AN1709)*.

Table 43. EMS characteristics

Symbol	Parameter	Conditions	Level/Class
V _{FESD}	Voltage limits to be applied on any I/O pin to induce a functional disturbance	V _{DD} = 3.3 V, T _A = 25°C, f _{HCLK} = 160 MHz, LQFP144 package conforming to IEC 61000-4-2	2B
V _{EFTB}	Fast transient voltage burst limits to be applied through 100 pF on V _{DD} and V _{SS} pins to induce a functional disturbance	V _{DD} = 3.3 V, T _A = 25°C, f _{HCLK} = 160 MHz, LQFP144 package conforming to IEC 61000-4-4	5A

Designing hardened software to avoid noise problems

The EMC characterization and optimization are performed at component level with a typical application environment and simplified MCU software. Note that good EMC performance is highly dependent on the user application and the software in particular.

Therefore it is recommended that the user applies EMC software optimization and prequalification tests in relation with the EMC level requested for the application.

Software recommendations

The software flowchart must include the management of runaway conditions such as:

- Corrupted program counter
- Unexpected reset
- Critical data corruption (control registers)

Prequalification trials

Most of the common failures (unexpected reset and program counter corruption) can be reproduced by manually forcing a low state on the NRST pin or the oscillator pins for one second.

To complete these trials, ESD stress can be applied directly on the device, over the range of specification values. When unexpected behavior is detected, the software can be hardened to prevent unrecoverable errors occurring. See application note *Software techniques for improving microcontrollers EMC performance (AN1015)* for more details.

Electromagnetic Interference (EMI)

The electromagnetic field emitted by the device is monitored while a simple application is executed (toggling two LEDs through the I/O ports). This emission test is compliant with IEC 61967-2 standard that specifies the test board and the pin loading.

Table 44. EMI characteristics for $f_{HSE} = 16$ MHz and $f_{HCLK} = 144$ MHz

Symbol	Parameter	Conditions	Monitored frequency band	Value	Unit
S_{EMI}	Peak ⁽¹⁾	$V_{DD} = 3.6$ V, $T_A = 25$ ° C, LQFP144 package compliant with IEC 61967-2	0.1 MHz to 30 MHz	15	dB μ V
			30 MHz to 130 MHz	1	
			130 MHz to 1 GHz	27	
			1 GHz to 2 GHz	20	
	Level ⁽²⁾		0.1 MHz to 2 GHz	4.0	-

1. Refer to the EMI radiated test section of the application note EMC design guide for STM8, STM32 and Legacy MCUs (AN1709).
2. Refer to the EMI level classification section of the application note EMC design guide for STM8, STM32 and Legacy MCUs (AN1709).

5.3.12 Electrical sensitivity characteristics

Based on three different tests (ESD, latch-up) using specific measurement methods, the device is stressed in order to determine its performance in terms of electrical sensitivity.

Electrostatic discharge (ESD)

Electrostatic discharges (a positive then a negative pulse separated by 1 second) are applied to the pins of each sample according to each pin combination. The sample size depends on the number of supply pins in the device (3 parts \times (n+1) supply pins). This test conforms to the ANSI/JEDEC standard.

Table 45. ESD absolute maximum ratings

Specified by design and not tested in production.

Symbol	Ratings	Conditions	Packages	Class	Maximum value ⁽¹⁾	Unit
$V_{ESD(HBM)}$	Electrostatic discharge voltage (human body model)	$T_A = 25$ °C conforming to ANSI/ESDA/JEDEC JS-001	All	2	2000	V
$V_{ESD(CDM)}$	Electrostatic discharge voltage (charge device model)	$T_A = 25$ °C conforming to ANSI/ESDA/JEDEC JS-002	LQFP 144	C3	750	
			LQFP 100			
			LQFP 80			
			LQFP 64			
			LQFP 48			
			LQFP 32			
			UFQFPN 48			
			UFQFPN 32			

1. Evaluated by characterization - Not tested in production.

Static latch-up

The following complementary static tests are required on three parts to assess the latch-up performance:

- A supply overvoltage is applied to each power supply pin.
- A current injection is applied to each input, output, and configurable I/O pin.

These tests are compliant with EIA/JESD 78E IC latch-up standard.

Table 46. Electrical sensitivities

Symbol	Parameter	Conditions	Class
LU	Static latch-up class	$T_A = 130$ °C conforming to JESD78	Level II A

5.3.13 I/O current injection characteristics

As a general rule, the current injection to the I/O pins, due to external voltage below V_{SS} or above V_{DDIOx} (for standard, 3.3 V-capable I/O pins) must be avoided during normal product operation. However, in order to give an indication of the robustness of the microcontroller if abnormal injection accidentally happens, some susceptibility tests are performed on a sample basis during the device characterization.

Functional susceptibility to I/O current injection

While a simple application is executed on the device, the device is stressed by injecting current into the I/O pins programmed in floating-input mode. While this current is injected into the I/O pin, one at a time, the device is checked for functional failures.

The failure is indicated by an out-of-range parameter, such as an ADC error above a certain limit (higher than 5 LSB TUE), out of conventional limits of induced leakage current on adjacent pins (out of the $5 \mu A/+0 \mu A$ range), or other functional failure (for example reset occurrence or oscillator frequency deviation).

The characterization results are given in the table below. The negative induced leakage current is caused by the negative injection. The positive induced leakage current is caused by the positive injection.

Table 47. I/O current injection susceptibility

The I/O structure options listed in this table can be a concatenation of options including the option explicitly listed. For instance, TT_a refers to any TT I/O with _a option. TT_xx refers to any TT I/O and FT_xx refers to any FT I/O.

Evaluated by characterization - Not tested in production.

Symbol	Description	Functional susceptibility		Unit
		Negative injection	Positive injection	
I_{INJ}	Injected current on PA4 pins	0	N/A	mA
	Injected current on all other pins	5	N/A	

5.3.14 I/O port characteristics

General input/output characteristics

Unless otherwise specified, the parameters given in Table 48 are derived from tests performed under the conditions summarized in Table 18. All I/Os are designed as CMOS and TTL-compliant.

Note: For information on GPIO configuration, refer to the application note STM32 GPIO configuration for hardware settings and low-power consumption (AN4899).

Table 48. I/O static characteristics

The I/O structure options listed in this table can be a concatenation of options including the option explicitly listed. For instance, TT_a refers to any TT I/O with _a option. TT_xx refers to any TT I/O and FT_xx refers to any FT I/O. All I/Os are CMOS- and TTL-compliant (no software configuration required). Their characteristics cover more than the strict CMOS-technology or TTL parameters. The coverage of these requirements is shown in the figure below. The minimum and maximum values are specified for a junction temperature (T_J) of 125°C.

Symbol	Parameter	Condition	Min	Typ	Max	Unit
V _{IL}	I/O input low level voltage	2.7 V < V _{DDIOx} < 3.6 V	-	-	0.3V _{DD} ⁽¹⁾	V
	I/O input low level voltage		-	-	0.4 V _{DD} - 0.1 ⁽²⁾	
V _{IH}	I/O input high level voltage	2.7 V < V _{DDIOx} < 3.6 V	0.7V _{DD} ⁽¹⁾	-	-	V
	I/O input high level voltage		0.52V _{DD} + 0.18 ⁽²⁾	-	-	
V _{HYS} ⁽²⁾	TT_xx, FT_xxx and NRST I/O input hysteresis	2.7 V < V _{DDIOx} < 3.6 V	-	300	-	mV
I _{leak} ⁽³⁾	FT_xx Input leakage current ⁽²⁾	0 < V _{IN} ≤ Max(V _{DDXXX}) ⁽⁴⁾	-	-	±200	nA
		Max(V _{DDXXX}) < V _{IN} ≤ Max(V _{DDXXX} + 1 V) ⁽⁵⁾⁽⁶⁾⁽⁴⁾	-	-	±2500	
		Max(V _{DDXXX} + 1) < V _{IN} ≤ 5.5 V ⁽⁵⁾⁽⁶⁾⁽⁴⁾	-	-	750	
	TT_xx Input leakage current	0 < V _{IN} ≤ Max(V _{DDXXX} + 1 V) ⁽⁴⁾	-	-	±200	
R _{PU}	Weak pull-up equivalent resistor ⁽⁷⁾	V _{IN} = V _{SS}	30	40	50	kΩ
R _{PD}	Weak pull-down equivalent resistor ⁽⁷⁾	V _{IN} = V _{DD}	30	40	50	kΩ
C _{IO}	I/O pin capacitance	-	-	5	-	pF

- Compliant with CMOS requirements.
- Specified by design - Not tested in production.
- This parameter represents the pad leakage of the I/O itself. The total product pad leakage is provided by the following formula:
 $I_{Total_leak_max} = 10 \mu A + [number\ of\ I/Os\ where\ V_{IN}\ is\ applied\ on\ the\ pad] \times I_{lk\ max}$.
- Max(V_{DDXXX}) is the maximum value of all the I/O supplies.
- To sustain a voltage higher than the minimum of V_{DD} or V_{DDA} plus 0.3 V, disable the internal pull-up and pull-down resistors.
- V_{IN} must be less than Max(V_{DDXXX}) + 3.6 V.
- The pull-up and pull-down resistors are designed with a true resistance in series with a switchable PMOS/NMOS. This PMOS/NMOS contribution to the series resistance is minimal (~10% order).

All I/Os are CMOS- and TTL-compliant (no software configuration required). Their characteristics cover more than the strict CMOS-technology or TTL parameters. The coverage of these requirements is shown in the following figure.

Figure 20. I/O input characteristics (all I/Os)

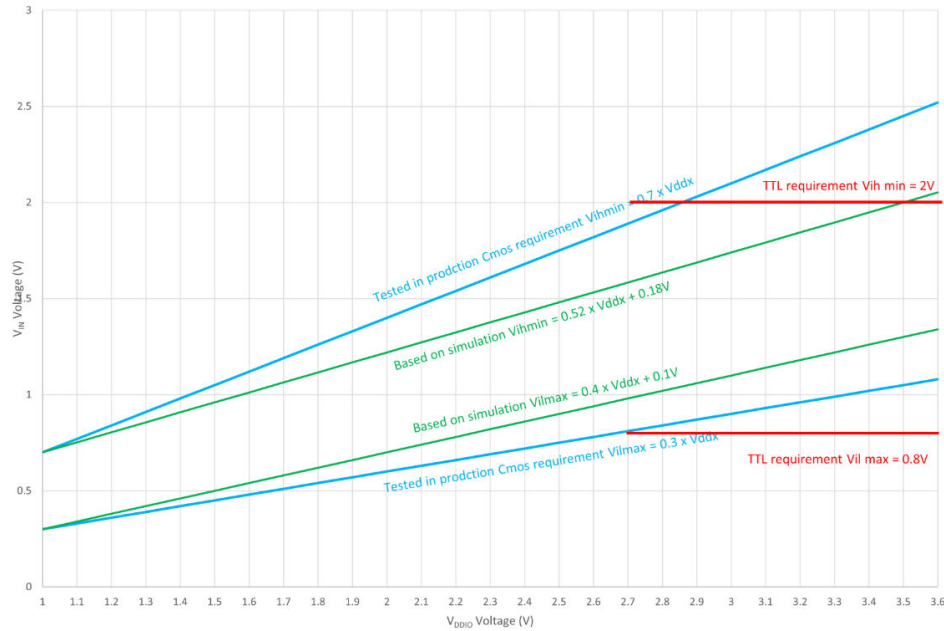

DT76156V1

Output driving current

The GPIOs (except PC13, PC14, PC15) can sink or source up to ± 8 mA, and sink or source up to ± 20 mA (with a relaxed V_{OL}/V_{OH}). PC13, PC14, PC15 are limited in source capability: +3 mA shared between the I/Os. These GPIOs have the same sink capability than other GPIOs.

In the user application, the number of I/O pins that can drive current must be limited to respect the absolute maximum rating specified in Section 5.2: Absolute maximum ratings:

- The sum of the currents sourced by all the I/Os on V_{DDIOx} , plus the maximum consumption of the MCU sourced on V_{DD} , cannot exceed the absolute maximum rating $\sum I_{VDD}$ (see Table 16. Current characteristics).
- The sum of the currents sunk by all the I/Os on V_{SS} , plus the maximum consumption of the MCU sunk on V_{SS} , cannot exceed the absolute maximum rating $\sum I_{VSS}$ (see Table 16. Current characteristics).

Output voltage levels

Unless otherwise specified, the parameters given in the table below are derived from tests performed under the ambient temperature and supply voltage conditions summarized in Table 18. All I/Os are CMOS- and TTL-compliant (FT or TT unless otherwise specified).

Table 49. Output voltage characteristics (all I/Os except PC14 and PC15)

The I/O structure options listed in this table can be a concatenation of options including the option explicitly listed. For instance, TT_a refers to any TT I/O with _a option. TT_xx refers to any TT I/O and FT_xx refers to any FT I/O.

TTL and CMOS outputs are compatible with JEDEC standards JESD36 and JESD52.

The I_O current sourced or sunk by the device must always respect the absolute maximum rating specified in Table 16, and the sum of the currents sourced or sunk by all the I/Os (I/O ports and control pins) must always respect the absolute maximum ratings ΣI_O.

The minimum and maximum values are specified for a junction temperature (T_J) of 125°C.

Symbol	Parameter	Conditions ⁽²⁾	Min	Max	Unit
V _{OL}	Output low-level voltage	CMOS port ⁽¹⁾ , I _O = 8 mA, 2.7 V ≤ V _{DD} ≤ 3.6 V	-	0.4V _{DD}	V
V _{OH}	Output high-level voltage	CMOS port ⁽¹⁾ , I _O = -8 mA, 2.7 V ≤ V _{DD} ≤ 3.6 V	V _{DD} - 0.4	-	
V _{OL} ⁽²⁾	Output low-level voltage	TTL port ⁽¹⁾ , I _O = 8 mA, 2.7 V ≤ V _{DD} ≤ 3.6 V	-	0.4	
V _{OH} ⁽²⁾	Output high-level voltage	TTL port ⁽¹⁾ , I _O = -8 mA, 2.7 V ≤ V _{DD} ≤ 3.6 V	2.4	-	
V _{OL} ⁽²⁾	Output low-level voltage	I _O = 20 mA, 2.7 V ≤ V _{DD} ≤ 3.6 V	-	1.3	
V _{OH} ⁽²⁾	Output high-level voltage	I _O = -20 mA, 2.7 V ≤ V _{DD} ≤ 3.6 V	V _{DD} - 1.3	-	
V _{OLFM+} ⁽²⁾	Output low-level voltage for a FT_f I/O pin in FM+ mode	I _O = 20 mA, 2.7 V ≤ V _{DD} ≤ 3.6 V	-	0.4	

1. TTL and CMOS outputs are compatible with JEDEC standards JESD36 and JESD52.

2. Specified by design - Not tested in production.

Table 50. Output voltage characteristics for PC14 and PC15

Specified by design and not tested in production.

The minimum and maximum values are specified for a junction temperature T_J = 125°C.

The I/O current sourced or sunk by the device must always comply with the absolute maximum rating specified in Table 16. **Current characteristics**. Additionally, the sum of the currents sourced or sunk by all the I/Os (I/O ports and control pins) must always comply with the absolute maximum ratings ΣI_O.

The minimum and maximum values are specified for a junction temperature (T_J) of 125°C.

Symbol	Parameter	Conditions ⁽³⁾	Min	Max	Unit
V _{OL}	Output low level voltage	CMOS port ⁽¹⁾ I _O =0.5 mA 2.7 V ≤ V _{DD} ≤ 3.6 V	-	0	V
V _{OH}	Output high level voltage	CMOS port ⁽¹⁾ I _O =-0.5 mA 2.7 V ≤ V _{DD} ≤ 3.6 V	V _{DD} - 0.4	-	
V _{OL} ⁽²⁾	Output low level voltage	TTL port ⁽¹⁾ I _O = 0.5 mA 2.7 V ≤ V _{DD} ≤ 3.6 V	-	0	
V _{OH} ⁽²⁾	Output high level voltage	TTL port ⁽¹⁾ I _O = -0.5 mA 2.7 V ≤ V _{DD} ≤ 3.6 V	2	-	

1. TTL and CMOS outputs are compatible with JEDEC standards JESD36 and JESD52.

2. Specified by design - Not tested in production.

Output AC characteristics

The definition and values of output AC characteristics are given in Figure 21. Output AC characteristics definition and in the table below respectively.

Unless otherwise specified, the parameters given are derived from tests performed under the ambient temperature and supply voltage conditions summarized in Table 18.

Table 51. Output AC characteristics (all I/Os except PC13)

The I/O structure options listed in this table can be a concatenation of options including the option explicitly listed. For instance, TT_a refers to any TT I/O with _a option. TT_xx refers to any TT I/O and FT_xx refers to any FT I/O.

The I/O speed is configured using the OSPEEDRy[1:0] bits. Refer to the product reference manual for a description of GPIO port configuration register

Specified by design - Not tested in production.

The minimum and maximum values are specified for a junction temperature $T_J = 125^\circ\text{C}$.

Speed	Symbol	Parameter	conditions	Min	Max	Unit
00	Fmax ⁽¹⁾	Maximum frequency	C = 50 pF, 2.7 V ≤ V _{DD} ≤ 3.6 V	-	4	MHz
			C = 30 pF, 2.7 V ≤ V _{DD} ≤ 3.6 V	-	4	
			C = 10 pF, 2.7 V ≤ V _{DD} ≤ 3.6 V	-	4	
	tr/tf ⁽²⁾	Output high to low level fall time and output low to high level rise time	C = 50 pF, 2.7 V ≤ V _{DD} ≤ 3.6 V	-	51	ns
			C = 30 pF, 2.7 V ≤ V _{DD} ≤ 3.6 V	-	46	
			C = 10 pF, 2.7 V ≤ V _{DD} ≤ 3.6 V	-	40	
01	Fmax ⁽¹⁾	Maximum frequency	C = 50 pF, 2.7 V ≤ V _{DD} ≤ 3.6 V	-	12	MHz
			C = 30 pF, 2.7 V ≤ V _{DD} ≤ 3.6 V	-	12	
			C = 10 pF, 2.7 V ≤ V _{DD} ≤ 3.6 V	-	12	
	tr/tf ⁽²⁾	Output high to low level fall time and output low to high level rise time	C = 50 pF, 2.7 V ≤ V _{DD} ≤ 3.6 V	-	19	ns
			C = 30 pF, 2.7 V ≤ V _{DD} ≤ 3.6 V	-	17	
			C = 10 pF, 2.7 V ≤ V _{DD} ≤ 3.6 V	-	14	
10	Fmax ⁽¹⁾⁽³⁾	Maximum frequency	C = 50 pF, 2.7 V ≤ V _{DD} ≤ 3.6 V	-	45	MHz
			C = 30 pF, 2.7 V ≤ V _{DD} ≤ 3.6 V	-	50	
			C = 10 pF, 2.7 V ≤ V _{DD} ≤ 3.6 V	-	55	
	tr/tf ⁽²⁾⁽³⁾	Output high to low level fall time and output low to high level rise time	C = 50 pF, 2.7 V ≤ V _{DD} ≤ 3.6 V	-	7	ns
			C = 30 pF, 2.7 V ≤ V _{DD} ≤ 3.6 V	-	6	
			C = 10 pF, 2.7 V ≤ V _{DD} ≤ 3.6 V	-	4	
11	Fmax ⁽¹⁾⁽³⁾	Maximum frequency	C = 50 pF, 2.7 V ≤ V _{DD} ≤ 3.6 V	-	90	MHz
			C = 30 pF, 2.7 V ≤ V _{DD} ≤ 3.6 V	-	96	
			C = 10 pF, 2.7 V ≤ V _{DD} ≤ 3.6 V	-	110	
	tr/tf ⁽²⁾⁽³⁾	Output high to low level fall time and output low to high level rise time	C = 50 pF, 2.7 V ≤ V _{DD} ≤ 3.6 V	-	5	ns
			C = 30 pF, 2.7 V ≤ V _{DD} ≤ 3.6 V	-	4	
			C = 10 pF, 2.7 V ≤ V _{DD} ≤ 3.6 V	-	3	

1. The maximum frequency is defined with the following conditions: $(tr+tf) \leq 2/3 T$
2. The fall and rise times are defined between 90% and 10% and between 10% and 90% of the output waveform, respectively.
3. Compensation system enabled.

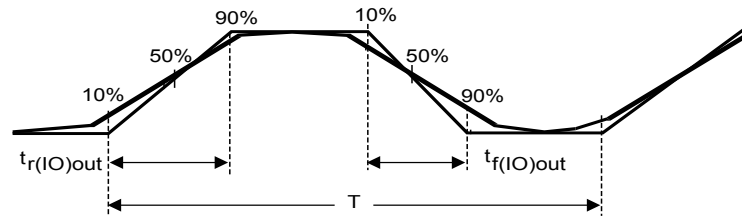
Figure 21. Output AC characteristics definition

Maximum frequency is achieved with a duty cycle at (45 - 55%) when loaded by the specified capacitance.

DT32132V4

5.3.15 NRST pin characteristics

The NRST pin input driver uses the CMOS technology. It is connected to a permanent pullup resistor, R_{PU} .

Unless otherwise specified, the parameters given in the table below are derived from tests performed under the ambient temperature and supply voltage conditions summarized in Table 18.

Table 52. NRST pin characteristics

Specified by design and not tested in production.

Symbol	Parameter	Conditions	Min	Typ	Max	Unit
$V_{IL(NRST)}$	NRST input low-level voltage	-	-	-	$0.3 \times V_{DDIOx}$	V
$V_{IH(NRST)}$	NRST input high-level voltage	-	$0.7 \times V_{DDIOx}$	-	-	V
$V_{hys(NRST)}$	NRST Schmitt trigger voltage hysteresis	-	-	200	-	mV
R_{PU}	Weak pull-up equivalent resistor ⁽¹⁾	$V_{IN} = V_{SS}$	30	40	50	k Ω
$t_{F(NRST)}$	NRST input filtered pulse	-	-	-	50	ns
$t_{NF(NRST)}$	NRST input not-filtered pulse	$2.7 V \leq V_{DD} \leq 3.6 V$	350	-	-	

1. The pull-up is designed with a true resistance in series with a switchable PMOS. This PMOS contribution to the series resistance is minimal (~10 % order).

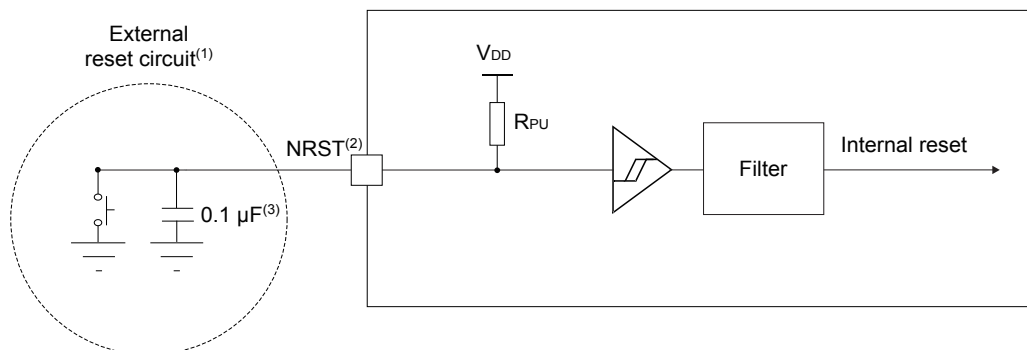
Figure 22. Recommended NRST pin protection

DT19878V3

- (1): The reset network protects the device against parasitic resets.
- (2): The user must ensure that the level on the NRST pin can go below the $V_{IL(NRST)}$ max level specified in the above table. Otherwise the reset is not taken into account by the device.
- (3): The external capacitor on NRST must be placed as close as possible to the device.

5.3.16 Extended interrupt and event controller input (EXTI) characteristics

The pulse on the interrupt input must have a minimal length in order to guarantee that it is detected by the event controller.

Table 53. EXTI input characteristics

Specified by design and not tested in production.

Symbol	Parameter	Conditions	Min	Typ	Max	Unit
PLEC	Pulse length to event controller	-	20	-	-	ns

5.3.17 XSPI interface characteristics

Unless otherwise specified, the parameters given in the following table are derived from tests performed under the ambient temperature , f_{HCLK} frequency, and V_{DD} supply voltage conditions summarized in Table 18. General operating conditions , with the following configuration:

- Output speed is set to OSPEEDRy[1:0] = 11
- Measurement points are done at CMOS levels: 0.5 V_{DD}
- IO compensation cell activated

Table 54. XSPI characteristics in SRD mode

Evaluated by characterization - Not tested in production.

All values apply to Octal- and Quad-SPI mode.

Delay block bypassed.

Symbol	Parameter	Conditions	Min	Typ	Max	Unit
$f_{(CLK)}$	Clock frequency	$2.7 V < V_{DD} < 3.6 V$ $C_L = 15 \text{ pF}$	-	-	72	MHz
$t_{w(CLKH)}$	OCTOSPI clock high and low time, even division	PRESCALER[7:0]= $n = (0,1,3,5,\dots,255)$	$t_{(CLK)}/2 - 0.5$	-	$t_{(CLK)}/2 + 0.5$	ns
$t_{w(CLKL)}$			$t_{(CLK)}/2 - 0.5$	-	$t_{(CLK)}/2 + 0.5$	
$t_{w(CLKH)}$	OCTOSPI clock high and low time, odd division	PRESCALER[7:0]= $n = (2,4,6,\dots,254)$	$(n/2) \times t_{(CLK)}/(n+1) - 0.5$	-	$(n/2) \times t_{(CLK)}/(n+1)$	
$t_{w(CLKL)}$			$(n/2+1) \times t_{(CLK)}/(n+1) - 0.5$	-	$(n/2+1) \times t_{(CLK)}/(n+1)$	
$t_{s(DQ)}$	Data input setup time	-	3	-	-	
$t_{h(DQ)}$	Data input hold time	-	1	-	-	
$t_{v(OUT)}$	Data output valid time	-	-	0.5	1.5	
$t_{h(OUT)}$	Data output hold time	-	0	-	-	

Table 55. XSPI characteristics in DTR mode (no DQS)

Evaluated by characterization - Not tested in production.

All values apply to Octal- and Quad-SPI mode.

Delay block bypassed.

Symbol	Parameter	Conditions	Min	Typ	Max	Unit
$f_{(CLK)}$	Clock frequency	$2.7 V < V_{DD} < 3.6 V$ $C_L = 15 \text{ pF}$	-	-	72 ⁽¹⁾	MHz
$t_{w(CLKL)}$	OCTOSPI clock high and low time Even division	PRESCALER[7:0] = n $= (0,1,3,5,\dots,255)$	$t_{(CLK)}/2 - 0.5$	-	$t_{(CLK)}/2 + 0.5$	ns
$t_{w(CLKH)}$			$t_{(CLK)}/2 - 0.5$	-	$t_{(CLK)}/2 + 0.5$	
$t_{w(CLKH)}$	OCTOSPI clock high and low time Even division	PRESCALER[7:0] = n $= (2,4,6,\dots,254)$	$(n/2) \times t_{(CLK)}/(n+1) - 0.5$	-	$(n/2) \times t_{(CLK)}/(n+1) + 0.5$	
$t_{w(CLKL)}$			$(n/2+1) \times t_{(CLK)}/(n+1) - 0.5$	-	$(n/2+1) \times t_{(CLK)}/(n+1) + 0.5$	

Symbol	Parameter	Conditions	Min	Typ	Max	Unit
$t_{sr(IN)}$ $t_{sf(IN)}$	Data input setup time	-	3	-	-	ns
$t_{hr(IN)}$ $t_{hf(IN)}$	Data input hold time	-	1	-	-	
$t_{vr(OUT)}$ $t_{vf(OUT)}$	Data output valid time	DHQC = 0	-	3.5	4.5	
		DHQC=1 All prescaler values (except 0)	-	$t_{(CLK)}/4 + 0.5$	$t_{(CLK)}/4 + 1.5$	
$t_{hr(OUT)}$ $t_{hf(OUT)}$	Data output hold time	DHQC = 0	1.5	-	-	
		DHQC=1, All prescaler values (except 0)	$t_{(CLK)}/4 - 0.5$	-	-	

1. DHQC must be set to reach the mentioned frequency.

Table 56. XSPI characteristics in DTR mode (with DQS) / HyperBus

Evaluated by characterization - Not tested in production.
 All values apply to Octal- and Quad-SPI mode.
 Delay block activated.

Symbol	Parameter	Conditions	Min	Typ	Max	Unit
$f_{(CLK)}$	Clock frequency	$2.7\text{ V} < V_{DD} < 3.6\text{ V}$ $C_L = 15\text{ pF}$	-	-	$72^{(1)(2)}$	MHz
$t_{w(CLKH)}$ $t_{w(CLKL)}$	OCTOSPI clock high and low time (even division)	PRESCALER[7:0] = n =(0,1,3,5,...,255)	$t_{(CLK)}/2 - 0.5$ $t_{(CLK)}/2 - 0.5$	- -	$t_{(CLK)}/2 + 0.5$ $t_{(CLK)}/2 + 0.5$	ns
$t_{w(CLKH)}$ $t_{w(CLKL)}$	OCTOSPI clock high and low time (odd division)	PRESCALER[7:0] = n =(2,4,6,...,254)	$(n/2) \times t_{(CLK)}/(n+1) - 0.5$ $(n/2+1) \times t_{(CLK)}/(n+1) - 0.5$	- -	$(n/2) \times t_{(CLK)}/(n+1) + 0.5$ $(n/2+1) \times t_{(CLK)}/(n+1) + 0.5$	
$t_{v(CLK)}$	Clock valid time	-	-	-	$t_{(CLK)} + 2$	
$t_{h(CLK)}$	Clock hold time	-	$t_{(CLK)}/2 - 1$	-	-	
$t_{w(CS)}$	Chip select high time	-	$3 \times t_{(CLK)}$	-	-	ns
$t_{v(DQ)}$	Data input valid time	-	0	-	-	
$t_{v(DS)}$	Data strobe input valid time	-	0	-	-	
$t_{h(DS)}$	Data strobe input hold time	-	0	-	-	
$t_{v(RWDS)}$	Data strobe output valid time	-	-	-	$3 \times t_{(CLK)}$	
$t_{sr(DQ)}$ $t_{sf(DQ)}$	Data input setup time	-	-1 ⁽³⁾	-	-	
$t_{hr(DQ)}$ $t_{hf(DQ)}$	Data input hold time	-	3	-	-	
$t_{vr(OUT)}$ $t_{vf(OUT)}$	Data output valid time	DHQC = 0	-	3.5	4.5	
		DHQC = 1, All prescaler values (except 0)	-	$t_{(CLK)}/4 + 0.5$	$t_{(CLK)}/4 + 1.5$	
$t_{hr(OUT)}$ $t_{hf(OUT)}$	Data output hold time	DHQC = 0	1.5	-	-	
		DHQC = 1, All prescaler values (except 0)	$t_{(CLK)}/4 - 0.5$	-	-	

1. Maximum frequency values are given for a RWDS to DQ skew of maximum $\pm 1.0\text{ ns}$.

2. DHQC must be set to reach the mentioned frequency.
3. Using $UNIT[6:0] = 0x28$ and $SEL[3:0] = 0x1$ in the DLYB_CFGR register.

Figure 23. OCTOSPI SDR read/write timing diagram

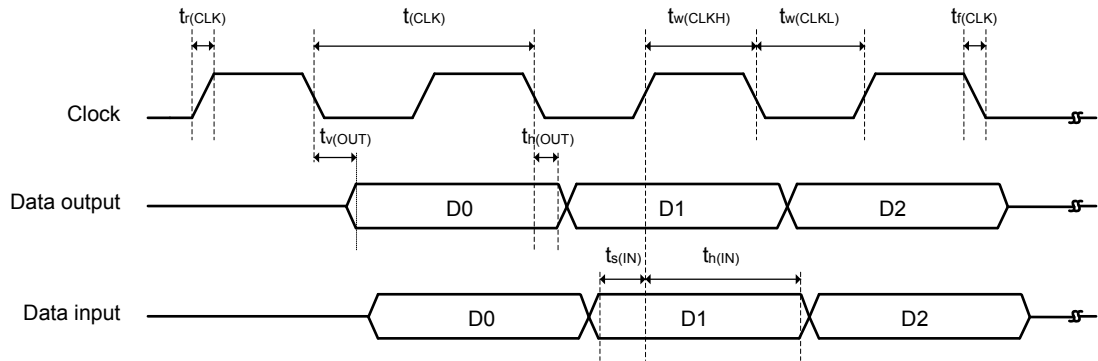

DT36878V1

Figure 24. OCTOSPI timing diagram - DTR mode

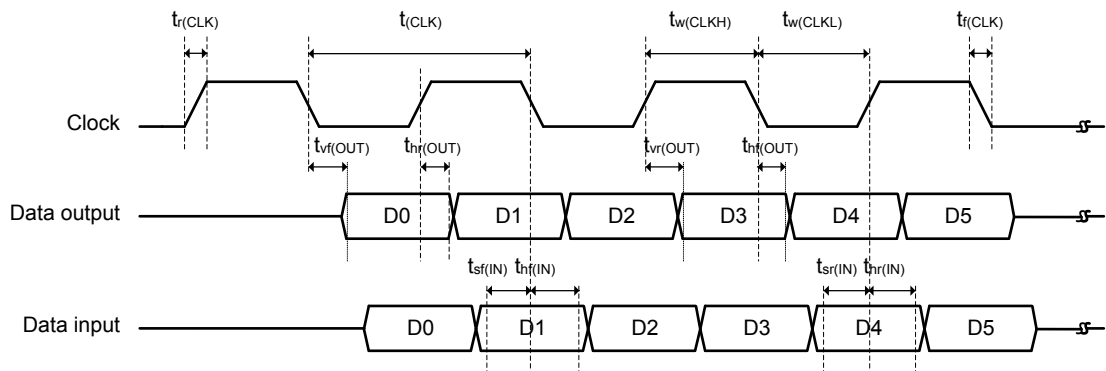

DT36878V1

Figure 25. OCTOSPI Hyperbus clock

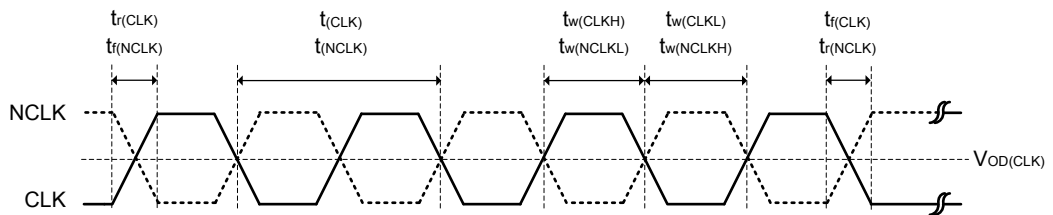

DT47732V1

Figure 26. OCTOSPI Hyperbus read

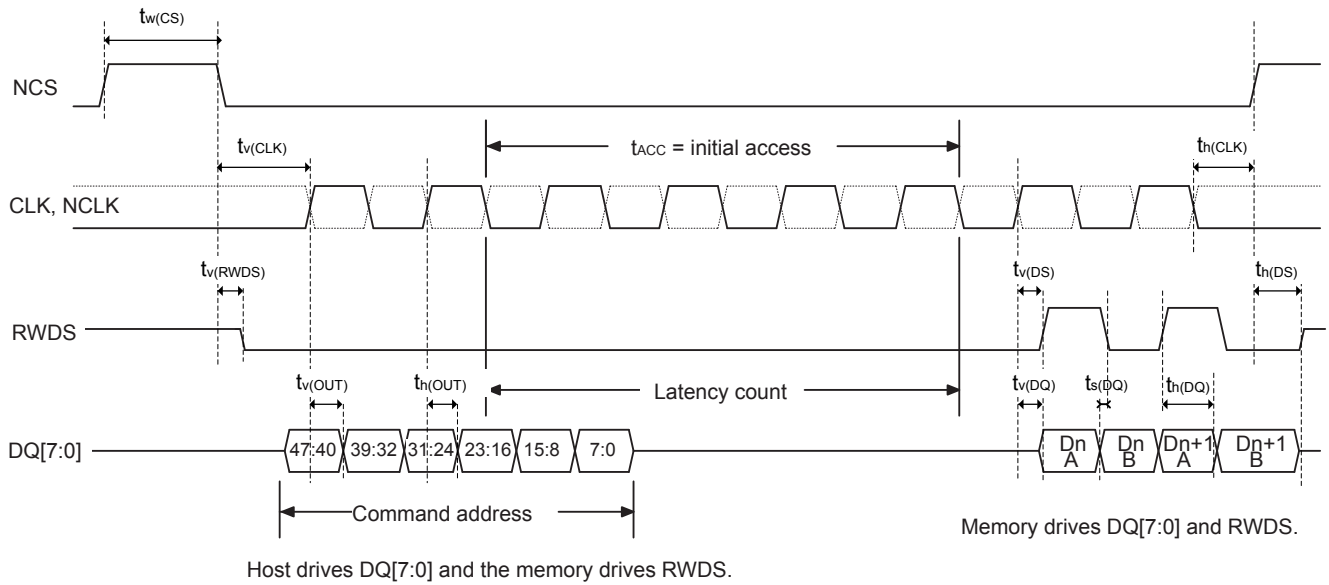

DT147733V1

Figure 27. OCTOSPI Hyperbus write

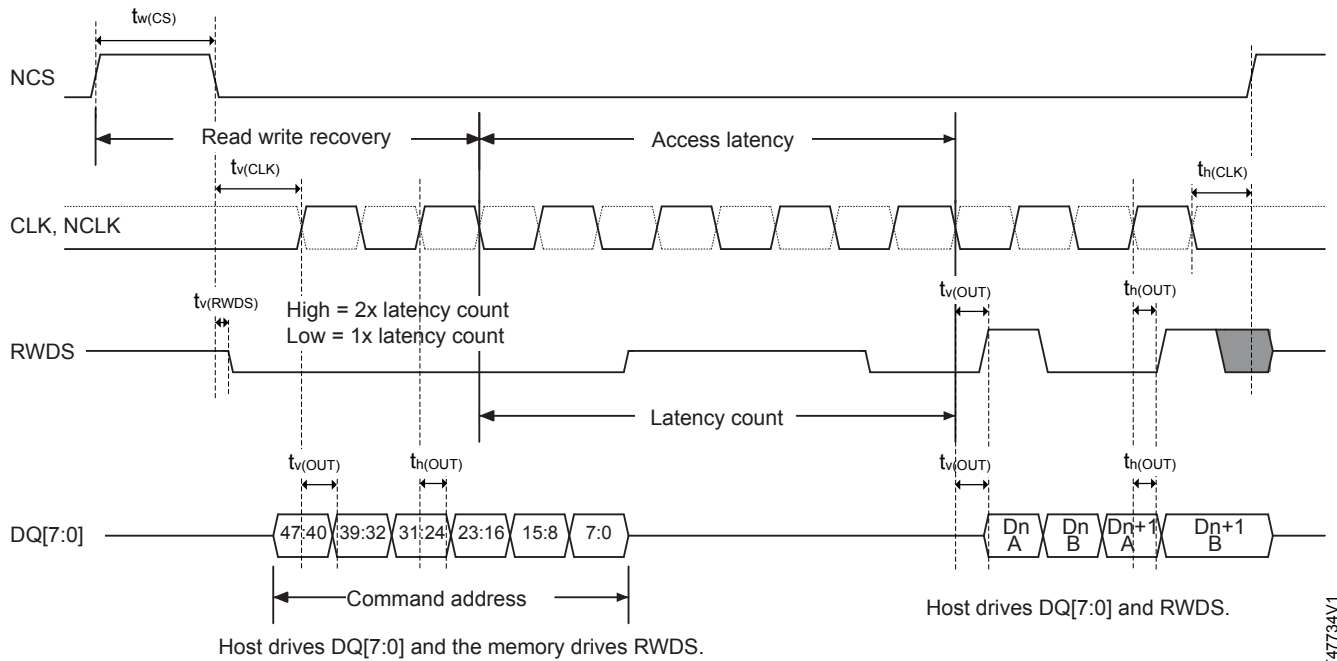

DT147734V1

5.3.18 Delay block (DLYB) characteristics

Unless otherwise specified, the parameters given in Table 57 for the delay block are derived from tests performed under the ambient temperature and V_{DD} supply voltage summarized in Table 1.

Table 57. DLYB characteristics

Evaluated by characterization, not tested in production unless otherwise specified.

Symbol	Parameter	Conditions	Min	Typ	Max	Unit
t_{init}	Initial delay	-	950	1400	1750	ps
t_{Δ}	Unit delay	-	40	52	64	ps

5.3.19 12-bit analog-to-digital converter ADC characteristics

Unless otherwise specified, the parameters given in Table 58 are values derived from tests performed under ambient temperature, f_{HCLK} frequency, and V_{DDA} supply voltage conditions summarized in Table 18.

Note: It is recommended to perform a calibration after each power-up.

Table 58. 12-bit ADC characteristics

Specified by design - Not tested in production.

Symbol	Parameter	Conditions				Min	Typ	Max	Unit		
V_{DDA}	Analog power supply for ADC ON	-				2.70	-	3.6	V		
V_{REF+}	Positive reference voltage	-				2.5	-	V_{DDA}			
V_{REF-}	Negative reference voltage	-				V_{SSA}					
f_{ADC}	ADC clock frequency	$2.7V \leq V_{DDA} \leq 3.6V$				8	-	36	MHz		
f_S with $R_{AIN}=47\ \Omega$ and $C_{PCB} = 22\ pF$	Sampling rate for slow channels	Resolution = 12 bits	All modes	$2.7V \leq V_{DDA} \leq 3.6V$	$-40^{\circ}C \leq T_J \leq 140^{\circ}C$	$f_{ADC} = 36\ MHz$	SMP = 2.5	-	2.25	-	MSPS
		Resolution = 10 bits					-	2.57	-		
		Resolution = 8 bits					-	3	-		
		Resolution = 6 bits					-	4.5	-		
t_{TRIG}	External trigger period	Resolution = 12 bits				16	-	-	$1/f_{ADC}$		
V_{AIN}	Conversion voltage range	-				0	-	V_{REF+}	V		
$R_{AIN}^{(1)}$	External input impedance	Resolution = 12 bits, $T_J = 140^{\circ}C$				-	-	110	Ω		
		Resolution = 12 bits, $T_J = 125^{\circ}C$				-	-	610			
		Resolution = 10 bits, $T_J = 140^{\circ}C$				-	-	2305			
		Resolution = 10 bits, $T_J = 125^{\circ}C$				-	-	4290			
		Resolution = 8 bits, $T_J = 140^{\circ}C$				-	-	11110			
		Resolution = 8 bits, $T_J = 125^{\circ}C$				-	-	15860			
		Resolution = 6 bits, $T_J = 140^{\circ}C$				-	-	46890			

Symbol	Parameter	Conditions	Min	Typ	Max	Unit
$R_{AIN}^{(1)}$	External input impedance	Resolution = 6 bits, $T_J = 125^\circ\text{C}$	-	-	79000	Ω
C_{ADC}	Internal sample and hold capacitor	-	-	3	-	pF
$t_{ADCVREG_STUP}$	ADC LDO startup time	-	-	-	10	μs
t_{STAB}	ADC power-up time	LDO already started	1	-	-	conversion cycle
t_{OFF_CAL}	Offset calibration time	-	85			$1/f_{ADC}$
t_{LATR}	Trigger conversion latency for regular and injected channels	Trigger from an asynchronous clock	3	-	4	
		Trigger from a synchronous clock	3			
t_s	Sampling time	-	2.5	-	288.5	
t_{CONV}	Total conversion time (including sampling time)	N-bits resolution	$t_s + 1.5 + N$			
$I_{DDA(ADC)}$	ADC consumption on V_{DD} , V_{DDA} and V_{REF}	$f_s = 2.25 \text{ MSPS}$	-	200	-	μA

1. High temperature generate leakage current on ADC inputs. This current create voltage drop through R_{AIN} directly affecting ADC accuracy (worst case when $V_{AIN} = V_{DDA}$). To limit this effect to a tolerance of 2LSBs, you must respect R_{AIN} max tables.

Table 59. 12-bit ADC accuracy

ADC accuracy values are measured after internal calibration. Resolution = 12 bits, no oversampling.

Evaluated by characterization on LQFP100. Packages without a V_{REF} - pad can have degraded specifications. Not tested in production.

Symbol	Parameter	Min	Typ	Max	Unit
ET	Total unadjusted error	-	4	5.7	LSB
EO	Offset error	-	± 2.5	± 5	
EG	Gain error	-	2.6	6	
ED	Differential linearity error	-1	-	1.3	
EL	Integral linearity error	-3	± 2.5	3	
ENOB	Effective number of bits	-	10.7	-	bits
SINAD	Signal-to-noise and distortion ratio	-	66	-	dB
SNR	Signal-to-noise ratio	-	68	-	
THD	Total harmonic distortion	-	-70	-	

Figure 28. Minimum sampling time versus RAIN for 12 bits resolution

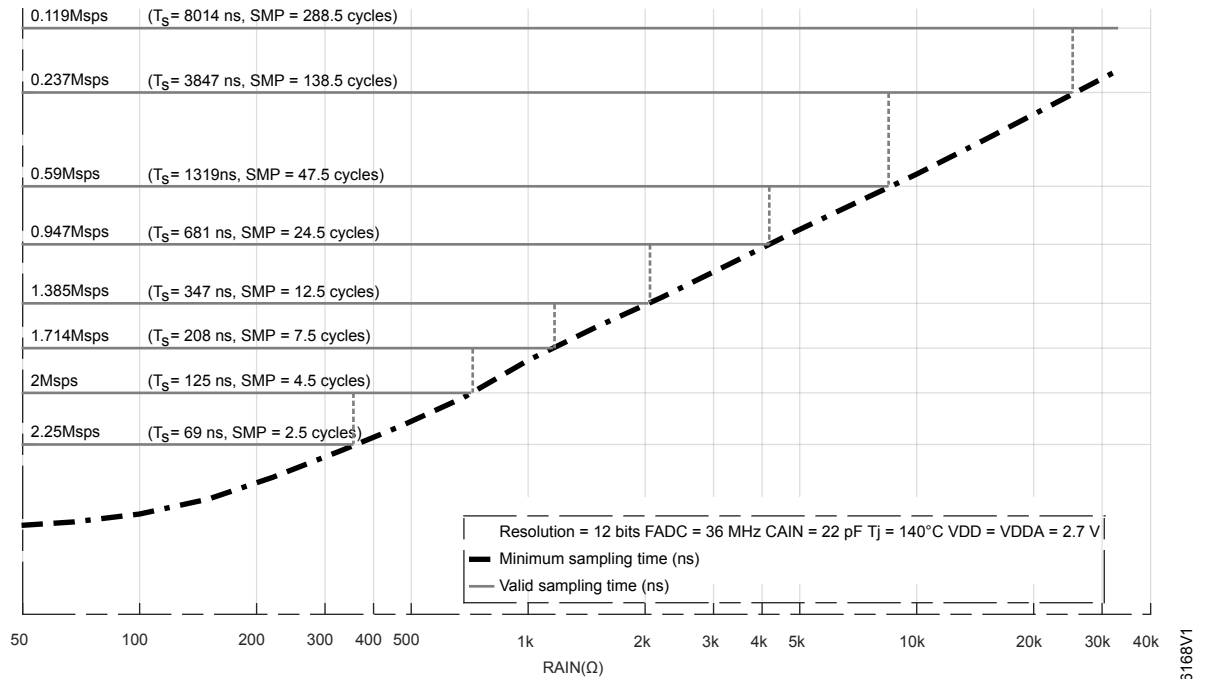

DT76168V1

Figure 29. Minimum sampling time versus RAIN for 10 bits resolution

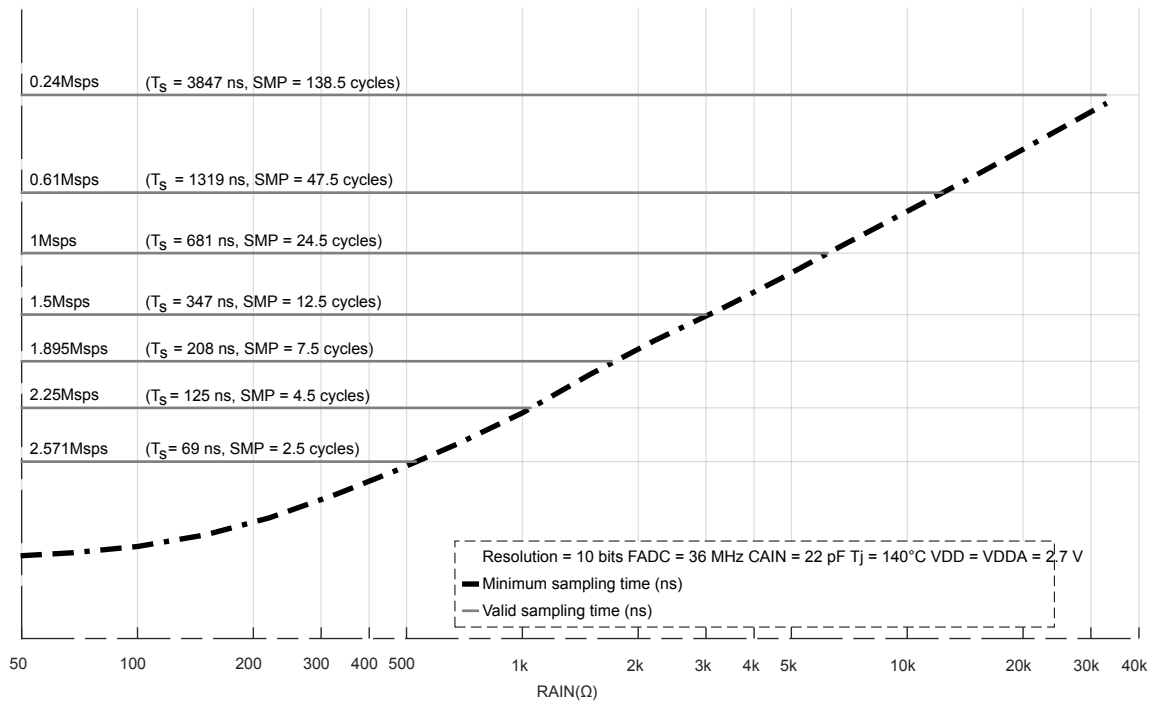

DT76167V1

Figure 30. Minimum sampling time versus RAIN for 8 bits resolution

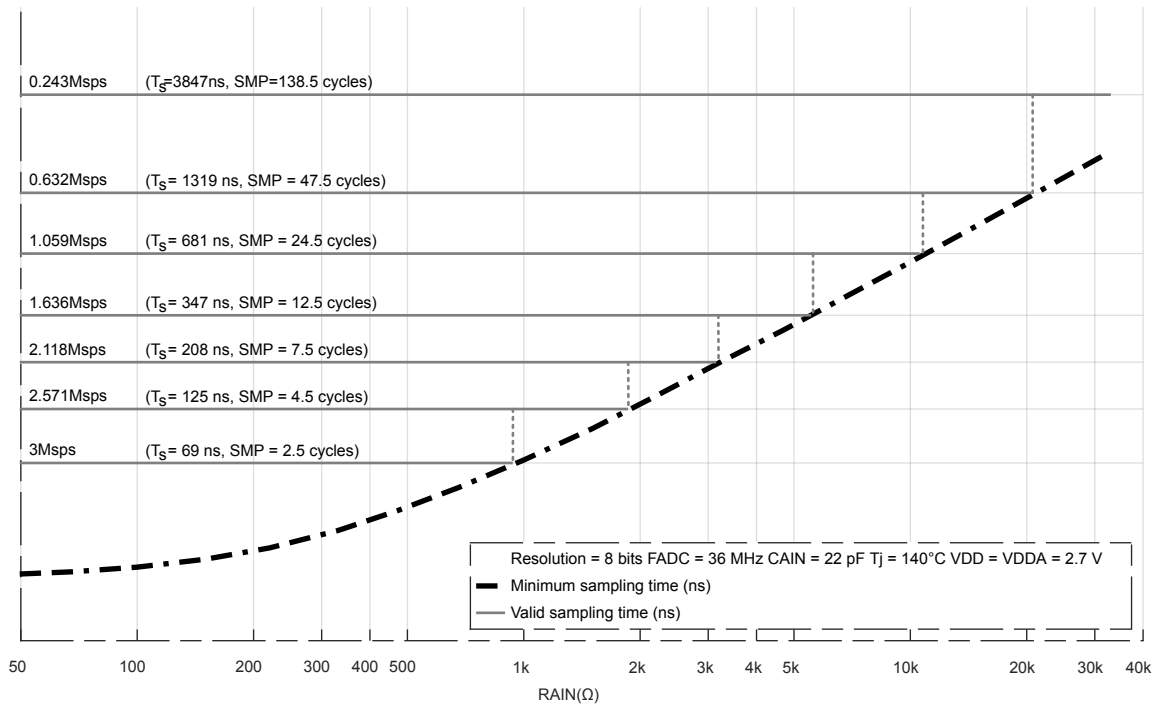

DT76170V1

Figure 31. Minimum sampling time versus RAIN for 6 bits resolution

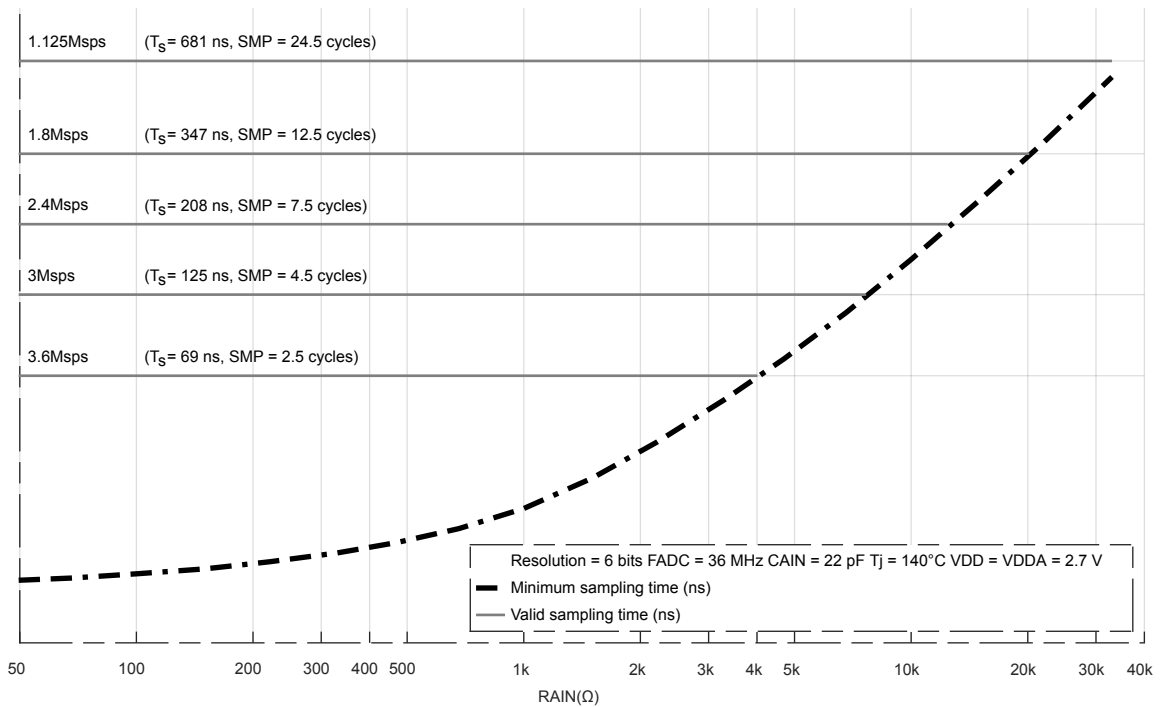

DT76169V1

Figure 32. ADC accuracy characteristics

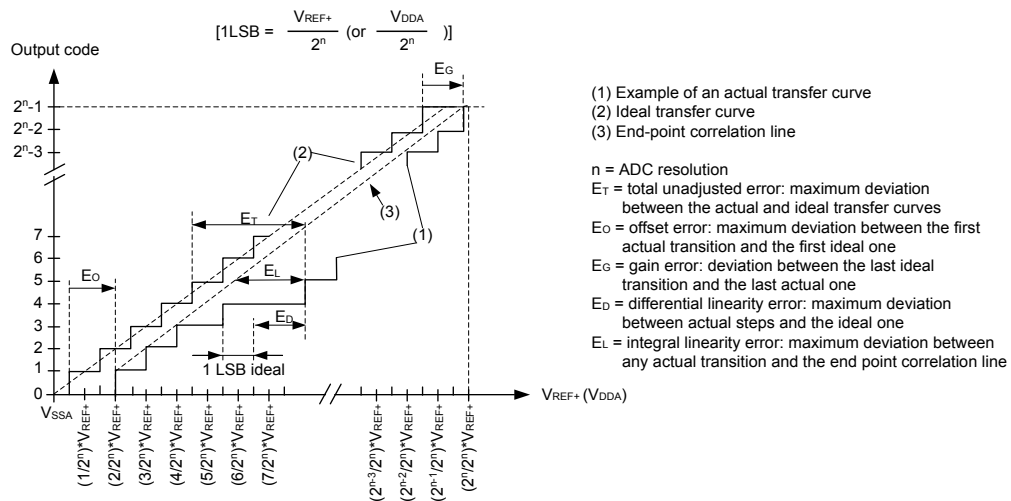

DT19880V6

Figure 33. Typical connection diagram when using the ADC with FT/TT pins featuring analog switch function

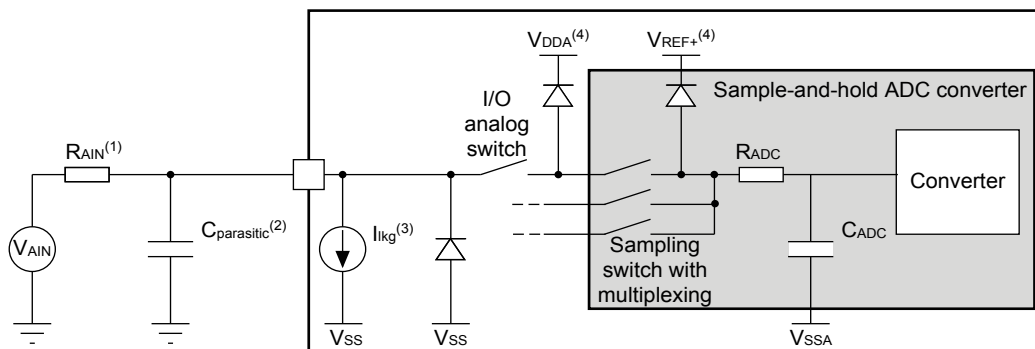

DT67871V3

- (1): Refer to the ADCx characteristic table for the values of R_{AIN} and C_{ADC} .
- (2): $C_{parasitic}$ represents the capacitance of the PCB (dependent on soldering and PCB layout quality) plus the pad capacitance (refer to Section 5.3.14: I/O port characteristics for the value of the pad capacitance). A high $C_{parasitic}$ value downgrades the conversion accuracy. To remedy this, f_{ADC} must be reduced.
- (3): Refer to Section 5.3.14: I/O port characteristics for the values of I_{ikg} .
- (4): Refer to Section 5.1.6: Power supply scheme.

General PCB design guidelines

The power-supply decoupling must be performed as shown in the corresponding power-supply scheme. The 100 nF capacitor must be ceramic (good quality) and must be placed as close as possible to the chip.

5.3.20 Temperature sensor characteristics

Table 60. Temperature sensor characteristics

Symbol	Parameter	Min	Typ	Max	Unit
$T_L^{(1)}$	V_{SENSE} linearity with temperature (from V_{sensor} voltage)	-	-	3	°C
	V_{SENSE} linearity with temperature (from ADC counter)	-	-	3	
Avg_Slope ⁽²⁾	Average slope (from V_{sense} voltage)	-	2.14	-	mV/°C
	Average slope (from ADC counter)	-	2.14	-	
$V_{30}^{(3)}$	Voltage at 30° C (± 1 ° C)	-	0.65	-	V
$t_{start_run}^{(1)}$	Startup time in Run mode (buffer startup)	-	-	25.2	μ s
$t_{S_temp}^{(1)}$	ADC sampling time when reading the temperature	13	-	-	
$I_{sens}^{(1)}$	Sensor consumption	-	0.18	0.29	μ A
$I_{sensbuf}^{(1)}$	Sensor buffer consumption	-	3.8	6.5	

1. Specified by design - Not tested in production.
2. Evaluated by characterization - Not tested in production.
3. Measured at $V_{DDA} = 3.3\text{ V} \pm 10\text{ mV}$. The V_{30} ADC conversion result is stored in the TS_CAL1 .

Table 61. Temperature sensor calibration values

Symbol	Parameter	Memory address
TS_CAL1	Temperature sensor raw data acquired value at 30 °C, $V_{DDA} = 3.3\text{ V}$	0x08FF F814 - 0x08FF F815
TS_CAL2	Temperature sensor raw data acquired value at 140 °C, $V_{DDA} = 3.3\text{ V}$	0x08FF F818 - 0x08FF F819

5.3.21 Digital-to-analog converter characteristics (DAC)

Table 62. DAC characteristics

Specified by design and not tested in production.

Symbol	Parameter	Conditions	Min	Typ	Max	Unit	
V_{DDA}	Analog supply voltage	-	2.7	-	-	V	
V_{REF+}	Positive reference voltage	-	2.5	-	V_{DDA}		
V_{REF-}	Negative reference voltage	-	-	V_{SSA}	-		
R_L	Resistive Load	DAC output buffer ON	connected to V_{SSA}	5	-	-	K Ω
			connected to V_{DDA}	25	-	-	
R_O	Output Impedance	DAC output buffer OFF	10.3	13.00	16		
R_{BON}	Output impedance sample and hold mode, output buffer ON	DAC output buffer ON	$V_{DD} = 2.7\text{ V}$	-	-	1.6	K Ω
R_{BOFF}	Output impedance sample and hold mode, output buffer OFF	DAC output buffer OFF	$V_{DD} = 2.7\text{ V}$	-	-	17.8	K Ω
C_L	Capacitive Load	DAC output buffer OFF	-	-	50	pF	
		Sample and Hold mode	-	0.10	1	μ F	
V_{DAC_OUT}	Voltage on DAC_OUT output	DAC output buffer ON	0.2	-	$V_{DDA} - 0.2$	V	
		DAC output buffer OFF	0	-	V_{REF+}		

Symbol	Parameter	Conditions	Min	Typ	Max	Unit	
$t_{SETTLING}$	Settling time (full scale: for a 12-bit code transition between the lowest and the highest input codes when DAC_OUT reaches the final value of $\pm 0.5\text{LSB}$, $\pm 1\text{LSB}$, $\pm 2\text{LSB}$, $\pm 4\text{LSB}$, $\pm 8\text{LSB}$)	Normal mode DAC output buffer ON $C_L \leq 50$ pF, $R_L \geq 5$ kW	± 0.5 LSB	-	1.7	3	μs
			± 1 LSB	-	1.66	2.87	
			± 2 LSB	-	1.65	2.84	
			± 4 LSB	-	1.63	2.78	
			± 8 LSB	-	1.61	2.7	
		Normal mode, DAC output buffer OFF, ± 1 LSB $C_L = 10$ pF	-	1.7	2		
t_{WAKEUP}	Wakeup time from off state (setting the Enx bit in the DAC Control register) until the $\pm 1\text{LSB}$ final value	Normal mode, DAC output buffer ON, $C_L \leq 50$ pF, $R_L = 5$ Ω	-	5	7.5	μs	
		Normal mode, DAC output buffer OFF, $C_L \leq 10$ pF	-	2	5.0		
PSRR	DC V_{DDA} supply rejection ratio	Normal mode DAC output buffer ON $C_L \leq 50$ pF, $R_L = 5$ kW	-	-80	-28	dB	
t_{SAMP}	Sampling time in Sample and Hold mode $C_{SH}=100\text{nF}$ (Code transition between the lowest input code and the highest input code when DACOUT reaches final value $\pm 1\text{LSB}$)	MODE<2:0>_V12 = 100/101 (BUFFER ON)	-	0.7	2.6	ms	
		MODE<2:0>_V12 = 110 (BUFFER OFF)	-	11.5	18.7		
		MODE<2:0>_V12=111 BUFFER OFF (DAC_OUT pin not connected, internal connection only)	-	0.3	0.6	μs	
I_{leak}	Output leakage current	-	-	-	-	nA	
C_{int}	Internal sample and hold capacitor	-	1.43	1.75	2	pF	
t_{TRIM}	Middle code offset trim time	DAC output buffer ON	50	-	-	μs	
V_{offset}	Middle code offset for 1 trim code step	$V_{REF+} = 3.6$ V	-	850	-	μV	
$I_{DDA}(\text{DAC})$	DAC quiescent consumption from V_{DDA}	DAC output buffer ON	No load, middle code (0x800)	-	315	-	μA
			No load, worst code (0xF1C)	-	450	-	
		DAC output buffer OFF	No load, middle/worst code (0x800)	-	20	-	
		Sample and Hold mode, $C_{SH}=100$ nF	-	$315 \cdot T_{on} / (T_{on} + T_{off})$	-		
$I_{DDV}(\text{DAC})$	DAC consumption from V_{REF+}	DAC output buffer ON	No load, middle code (0x800)	-	185	-	μA
			No load, worst code (0xF1C)	-	185	-	
		DAC output buffer OFF	No load, middle/worst code (0x800)	-	155	-	
		Sample and Hold mode, Buffer ON, $C_{SH}=100$ nF (worst code)	-	$185 \cdot T_{on} / (T_{on} + T_{off})$	-		
		Sample and Hold mode, Buffer OFF, $C_{SH}=100$ nF (worst code)	-	$155 \cdot T_{on} / (T_{on} + T_{off})$	-		

Figure 34. 12-bit buffered/non-buffered DAC

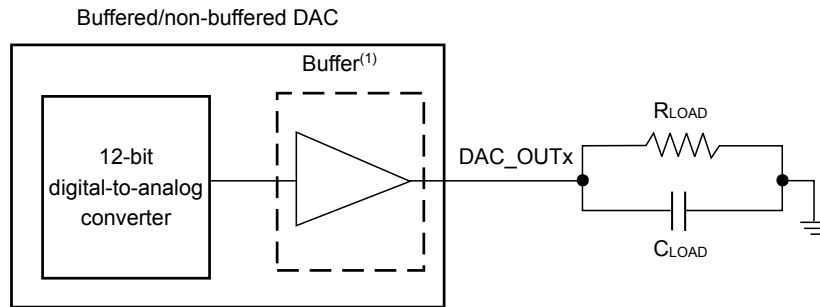

(1) The DAC integrates an output buffer that can be used to reduce the output impedance and to drive external loads directly without the use of an external operational amplifier. The buffer can be bypassed by configuring the BOFFx bit in the DAC_CR register.

DT47959V2

Table 63. DAC accuracy

Specified by design - not tested in production unless otherwise stated.

Symbol	Parameter	Conditions	Min	Typ	Max	Unit
DNL	Differential non linearity ⁽¹⁾	DAC output buffer ON	-2	-	2	LSB
		DAC output buffer OFF	-2	-	2	
	Monotonicity	10 bits	-	-	-	-
INL	Integral non linearity ⁽²⁾	DAC output buffer ON, $C_L \leq 50 \text{ pF}$, $R_L \geq 5 \text{ } \Omega$	-4	-	4	LSB
		DAC output buffer OFF, $C_L \leq 50 \text{ pF}$, no R_L	-4	-	4	
Offset	Offset error at code 0x800 ⁽²⁾	DAC output buffer ON, $C_L \leq 50 \text{ pF}$, $R_L \geq 5 \text{ } \Omega$ $V_{REF+} = 3.6 \text{ V}$	-	-	± 12	LSB
		DAC output buffer OFF, $C_L \leq 50 \text{ pF}$, no R_L	-	-	± 8	
Offset1	Offset error at code 0x001 ⁽³⁾	DAC output buffer OFF, $C_L \leq 50 \text{ pF}$, no R_L	-	-	± 5	LSB
OffsetCal	Offset error at code 0x800 after factory calibration	DAC output buffer ON, $C_L \leq 50 \text{ pF}$, $R_L \geq 5 \text{ } \Omega$ $V_{REF+} = 3.6 \text{ V}$	-	-	± 5	LSB
Gain	Gain error ⁽⁴⁾	DAC output buffer ON, $C_L \leq 50 \text{ pF}$, $R_L \geq 5 \text{ } \Omega$	-	-	± 1	%
		DAC output buffer OFF, $C_L \leq 50 \text{ pF}$, no R_L	-	-	± 1	
TUE	Total unadjusted error	DAC output buffer ON $C_L \leq 50 \text{ pF}$, $R_L \geq 5 \text{ k}\Omega$	-	-	± 30	LSB
		DAC output buffer OFF $C_L \leq 50 \text{ pF}$, no R_L	-	-	± 12	
TUECal	Total unadjusted error after calibration	DAC output buffer ON $C_L \leq 50 \text{ pF}$, $R_L \geq 5 \text{ k}\Omega$	-	-	± 23	LSB
SNR	Signal-to-noise ratio ⁽⁵⁾	DAC output buffer ON $C_L \leq 50 \text{ pF}$, $R_L \geq 5 \text{ k}\Omega$ 1 kHz, BW 500KHz	-	67.8	-	dB
		DAC output buffer OFF $C_L \leq 50 \text{ pF}$, no R_L 1 kHz, BW 500 KHz	-	67.8	-	
THD	Total harmonic distortion ⁽⁵⁾	DAC output buffer ON $C_L \leq 50 \text{ pF}$, $R_L \geq 5 \text{ k}\Omega$, 1 kHz	-	-78,6	-	dB
		DAC output buffer OFF $C_L \leq 50 \text{ pF}$, no R_L , 1 kHz	-	-78,6	-	
SINAD	Signal-to-noise and distortion ratio ⁽⁵⁾	DAC output buffer ON $C_L \leq 50 \text{ pF}$, $R_L \geq 5 \text{ k}\Omega$, 1 kHz	-	67.5	-	dB
		DAC output buffer OFF $C_L \leq 50 \text{ pF}$, no R_L , 1 kHz	-	67.5	-	
ENOB	Effective number of bits	DAC output buffer ON $C_L \leq 50 \text{ pF}$, $R_L \geq 5 \text{ k}\Omega$, 1 kHz	-	10.9	-	bits
		DAC output buffer OFF $C_L \leq 50 \text{ pF}$, no R_L , 1 kHz	-	10.9	-	

1. Difference between two consecutive codes minus 1 LSB.
2. Difference between the value measured at Code i and the value measured at Code i on a line drawn between Code 0 and last Code 4095.
3. Difference between the value measured at Code (0x001) and the ideal value.
4. Difference between the ideal slope of the transfer function and the measured slope computed from code 0x000 and 0xFFFF when the buffer is OFF, and from code giving 0.2 V and ($V_{REF+} - 0.2 \text{ V}$) when the buffer is ON.
5. The signal is -0.5 dBFS with $F_{\text{sampling}} = 1 \text{ MHz}$.

5.3.22 Comparator characteristics

Table 64. COMP characteristics

The input capacitance is negligible compared to the I/O capacitance.

Specified by design - not tested in production, unless otherwise stated.

Symbol	Parameter	Conditions	Min	Typ	Max	Unit
V_{DDA}	Analog supply voltage	-	2.70	-	3.60	V
V_{IN}	Comparator input voltage range	-	0	-	V_{DDA}	
V_{BG}	Scaler input voltage	-	(1)			
V_{SC}	Scaler offset voltage	-	-	± 5	± 10	

Symbol	Parameter	Conditions	Min	Typ	Max	Unit	
I _{DDA(SCALER)}	Scaler static consumption from V _{DDA}	BRG_EN=0 (bridge disable)	-	0.2	0.3	μA	
		BRG_EN=1 (bridge enable)	-	0.82	1		
t _{START_SCALER}	Scaler startup time	-	-	140	250	μs	
t _{START}	Comparator startup time to reach propagation delay specification	High-speed mode	-	2	5	μs	
		Medium mode	-	5	20		
t _D ⁽²⁾	Propagation delay for 200 mV step with 100 mV overdrive	High-speed mode	-	50	80	ns	
		Medium mode	-	0.5	0.9	μs	
	Propagation delay for step > 200 mV with 100 mV overdrive only on positive inputs	High-speed mode	-	50	120	ns	
		Medium mode	-	0.5	1.2	μs	
V _{offset}	Comparator offset error	Full common mode range	-	-	±20	mV	
V _{hys}	Comparator hysteresis	No hysteresis	-	0	-	mV	
		Low hysteresis	-	10	-		
		Medium hysteresis	-	20	-		
		High hysteresis	-	30	-		
I _{DDA(COMP)}	Comparator consumption from V _{DDA}	Medium mode	Static	-	5	9	μA
			With 50 kHz ±100 mV overdrive square signal	-	6	-	
		High-speed mode	Static	-	70	110	
			With 50 kHz ±100 mV overdrive square signal	-	75	-	

1. Refer to [Section 5.3.5: Embedded voltage reference](#).
2. Evaluated by characterization - Not tested in production.

5.3.23 Timer characteristics

The parameters given in [Section 5.3.23, Table 66](#), and [Section 5.3.23](#) are specified by design, not tested in production.

Refer to [Table 48. I/O static characteristics](#) for details on the input/output alternate function characteristics (output compare, input capture, external clock, PWM output).

Table 65. TIMx characteristics

Symbol	Parameter	Conditions	Min	Max	Unit ⁽¹⁾
t _{res(TIM)}	Timer resolution time	-	1	-	t _{TIMxCLK}
		f _{TIMxCLK} = 144 MHz	6.9	-	ns
f _{EXT}	Timer external clock frequency on CH1 to CH4	-	0	f _{TIMxCLK} /2	MHz
		f _{TIMxCLK} = 144 MHz	0	72	
Res _{TIM}	Timer resolution	TIMx (except TIM2/TIM5)	-	16	bit
		TIM2/TIM5	-	32	
t _{COUNTER}	16-bit counter clock period	-	1	65536	t _{TIMxCLK}
		f _{TIMxCLK} = 144 MHz	0.007	455.1	μs
t _{MAX_COUNT}	Maximum possible count with 32-bit counter	-	-	4, 294, 967, 296	t _{TIMxCLK}
		f _{TIMxCLK} = 144 MHz	-	29.826	s

1. TIMx, is used as a general term in which x stands for 1, 2, 5, 6, 7, 8, 12, 15, 16, 17.

Table 66. IWDG min/max timeout period at 32 kHz (LSI)

For the values in this table, the exact timings still depend on the phasing of the APB interface clock versus the LSI clock, so that there is always a full RC period of uncertainty.

Prescaler divider	PR[2:0] bits	Min timeout RL[11:0] = 0x000	Max timeout RL[11:0] = 0xFF	Unit
/4	0	0.125	512	ms
/8	1	0.250	1024	
/16	2	0.500	2048	
/32	3	1.0	4096	
/64	4	2.0	8192	
/128	5	4.0	16384	
/256	6 or 7	8.0	32768	

5.3.24 I3C interface characteristics

The I3C interface meets the timing requirements of the MIPI® I3C specification v1.1.

The I3C peripheral supports:

- I3C SDR-only as controller
- I3C SDR-only as target
- I3C SCL bus clock frequency up to 12.5 MHz

The parameters given in Table 67 below are obtained with the following configuration:

- Output speed is set to OSPEEDRy[1:0] = 10
- I/O Compensation cell activated
- Voltage scaling range 1

The I3C timings are in line with the MIPI specification, except for the ones given in Table 67, I3C open-drain measured timing. For t_{SU_OD} , this can be mitigated by increasing the corresponding SCL low duration in the I3C_TIMINGR0 register. For further details refer to AN5879.

Table 67. Open drain timing measurements

Evaluated by characterization - Not tested in production.

Symbol	Parameter	Conditions	Min	Unit
t_{SU_OD}	SDA data setup time in open drain mode	Controller $2.7\text{ V} \leq V_{DDIOX} \leq 3.6\text{ V}$	24.5 ⁽¹⁾	ns

1. The minimum SDA data setup time during open-drain-mode is 3 ns, as specified in the MIPI Alliance specification for I3C.

5.3.25 I2C interface characteristics

The I2C interface meets the timing requirements of the I2C-bus specification and user manual rev. 03 for:

- Standard mode (Sm): Bit rate up to 100 kbit/s.
- Fast mode (Fm): Bit rate up to 400 kbit/s.
- Fast mode plus (Fm+): Bit rate up to 1 Mbit/s.

The I2C timing requirements are specified by design, not tested in production, when the I2C peripheral is properly configured (refer to the product reference manual).

The SDA and SCL I/O requirements are met with the following restrictions:

- The SDA and SCL I/O pins are not true open-drain. When configured as open-drain, the PMOS connected between the I/O pin and V_{DDIOX} is disabled but remains present.
- Only FT_f I/O pins support Fm+ low level output current maximum requirement. Refer to Section 5.3.14: I/O port characteristics for the I2C I/Os characteristics.

All I2C SDA and SCL I/Os embed an analog filter. Refer to the table below for the analog filter characteristics.

Table 68. I²C analog filter characteristics

Evaluated by characterization - Not tested in production.
 Measurement points are taken at 50% V_{DD}.

Symbol	Parameter	Min	Max	Unit
t _{AF}	Maximum pulse width of spikes that are suppressed by analog filter	50 ⁽¹⁾	160 ⁽²⁾	ns

- Spikes with widths below t_{AF(min)} are filtered.
- Spikes with widths above t_{AF(max)} are not filtered.

5.3.26

USART characteristics

Unless otherwise specified, the parameters given in Table 69 are derived from tests performed under the ambient temperature, f_{PCLKx} frequency and V_{DD} supply voltage conditions summarized in not found, with the following configuration:

- Output speed set to OSPEEDRy[1:0] = 10
- Capacitive load C_L = 30 pF
- Measurement points done at 0.5 × V_{DD} level
- I/O compensation cell activated

Refer to I/O port characteristics for more details on the input/output alternate function characteristics (NSS, CK, TX, RX for USART).

Table 69. USART characteristics

Evaluated by characterization - Not tested in production.

Symbol	Parameter	Conditions	Min	Typ	Max	Unit	
f _{CK}	USART clock frequency	Master transmitter mode, 2.7 V ≤ V _{DD} ≤ 3.6 V	-	-	18		
		Slave receiver mode, 2.7 V ≤ V _{DD} ≤ 3.6 V	-	-	48		
		Slave transmitter mode, 2.7 V ≤ V _{DD} ≤ 3.6 V	-	-	26		
t _{su(NSS)}	NSS setup time	Slave mode	t _{ker} ⁽¹⁾ + 2	-	-	ns	
t _{h(NSS)}	NSS hold time	Slave mode	2	-	-		
t _{w(CKH)}	CK high and low time	Master mode	1/ f _{CK} /2-1	1/ f _{CK} /2	1/ f _{CK} /2+1		
t _{w(CKL)}							
t _{su(RX)}	Data input setup time	Master mode	18	-	-		
t _{su(RX)}		Slave mode	2.5	-	-		
t _{h(RX)}	Data input hold time	Master mode	0.5	-	-		
t _{h(RX)}		Slave mode	1	-	-		
t _{v(TX)}	Data output valid time	Slave mode	2.7 V ≤ V _{DD} ≤ 3.6 V	-	13.5		19
		Master mode	2.7 V ≤ V _{DD} ≤ 3.6 V	-	2.5		3
t _{h(TX)}	Data output hold time	Slave mode	10	-	-		
t _{h(TX)}	Data output hold time	Master mode	1	-	-		

- T_{ker} is the usart_ker_ck_pres clock period.

Figure 35. USART timing diagram in SPI master mode

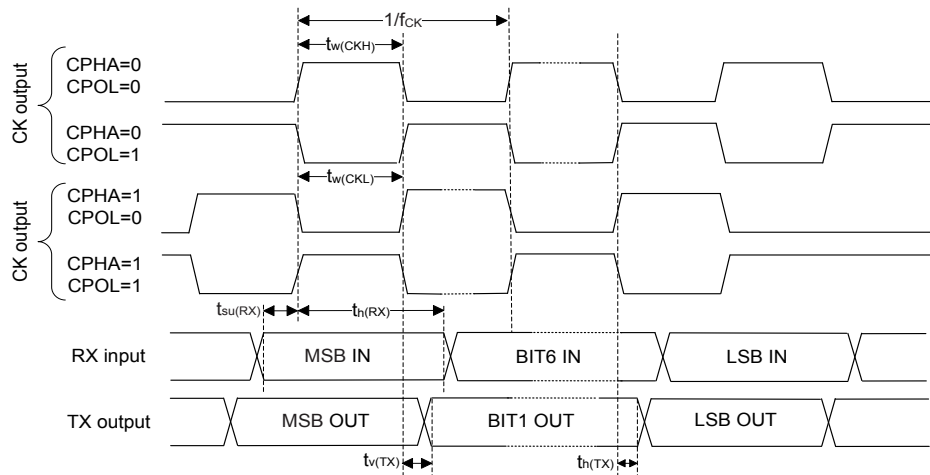

DT65386V2

Figure 36. USART timing diagram in SPI slave mode

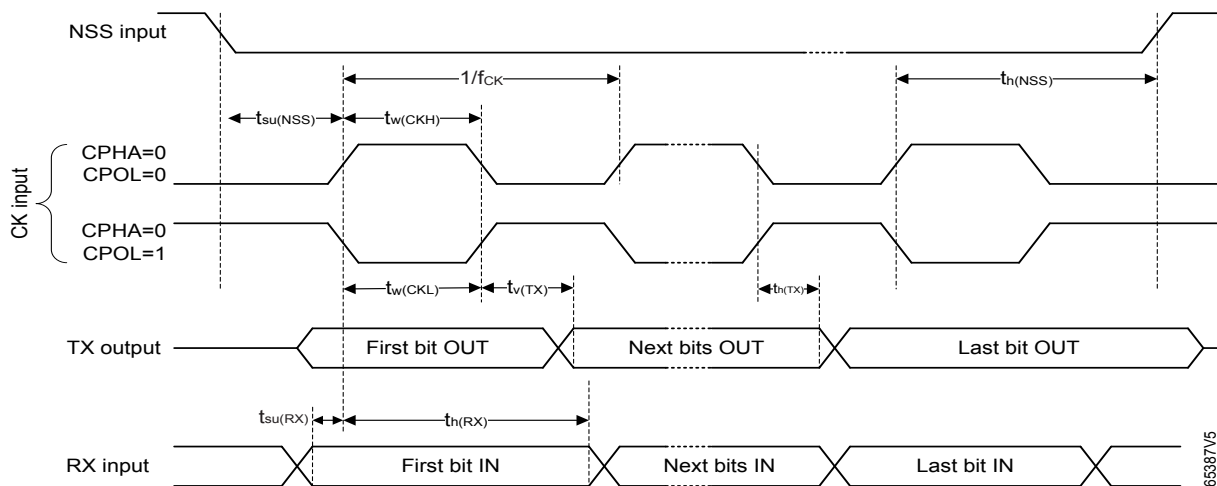

DT65387V5

5.3.27 SPI characteristics

Unless otherwise specified, the parameters given in Table 70 are derived from tests performed under the ambient temperature, f_{PCLKx} frequency and supply voltage conditions summarized in Table 18.

- Output speed set to $OSPEEDR[1:0] = 11$
- Capacitive load $C_L = 30$ pF
- Measurement points done at $0.5 \times V_{DD}$ level
- I/O compensation cell activated

Refer to Table 48. I/O static characteristics for more details on the input/output alternate function characteristics (NSS, SCK, MOSI, MISO for SPI).

Table 70. SPI characteristics

Evaluated by characterization - Not tested in production.

Symbol	Parameter	Conditions	Min	Typ	Max	Unit
f_{SCK}	SPI clock frequency	Master mode, $2.7 V \leq V_{DD} \leq 3.6 V$	-	-	72	MHz

Symbol	Parameter	Conditions	Min	Typ	Max	Unit	
f_{SCK}	SPI clock frequency	Slave receiver mode, $2.7 V \leq V_{DD} \leq 3.6 V$	-	-	100	MHz	
		Slave transmitter mode, $2.7 V \leq V_{DD} \leq 3.6 V$	-	-	30		
$t_{su(NSS)}$	NSS setup time	Slave mode	3	-	-	ns	
$t_{h(NSS)}$	NSS hold time	Slave mode	1	-	-		
$t_w(SCKH)$	SCK high and low time	Master mode	$T_{SCK}^{(1)} - 1$	$T_{SCK}^{(1)}$	$T_{SCK}^{(1)} + 1$		
$t_w(SCKL)$							
$t_{su(MI)}$	Data input setup time	Master mode	DRDS = 0	3	-		-
			DRDS = 1	$13 - T_{SCK}/2^{(1)}$	-		-
$t_{su(SI)}$		Slave mode	2	-	-		
$t_{h(MI)}$	Data input hold time	Master mode	DRDS = 0	1.5	-		-
			DRDS = 1	$T_{SCK}/2^{(1)} - 8$	-		-
$t_{h(SI)}$		Slave mode	1.5	-	-		
$t_{a(SO)}$	Data output access time	Slave mode	11	13.5	16.5		
$t_{dis(SO)}$	Data output disable time	Slave mode	9.5	11.5	14		
$t_v(SO)$	Data output valid time	Slave mode, $2.7 V \leq V_{DD} \leq 3.6 V$	-	12	16.5		
$t_v(MO)$	Data output valid time	Master mode	-	1.5	2		
$t_h(SO)$	Data output hold time	Slave mode (after enable edge)	8	-	-		
$t_h(MO)$	Data output hold time	Master mode (after enable edge)	0	-	-		

1. $T_{SCK} = T_{PCLK} \times \text{Baud rate prescaler}/2$.

Figure 37. SPI timing diagram - slave mode and CPHA = 0

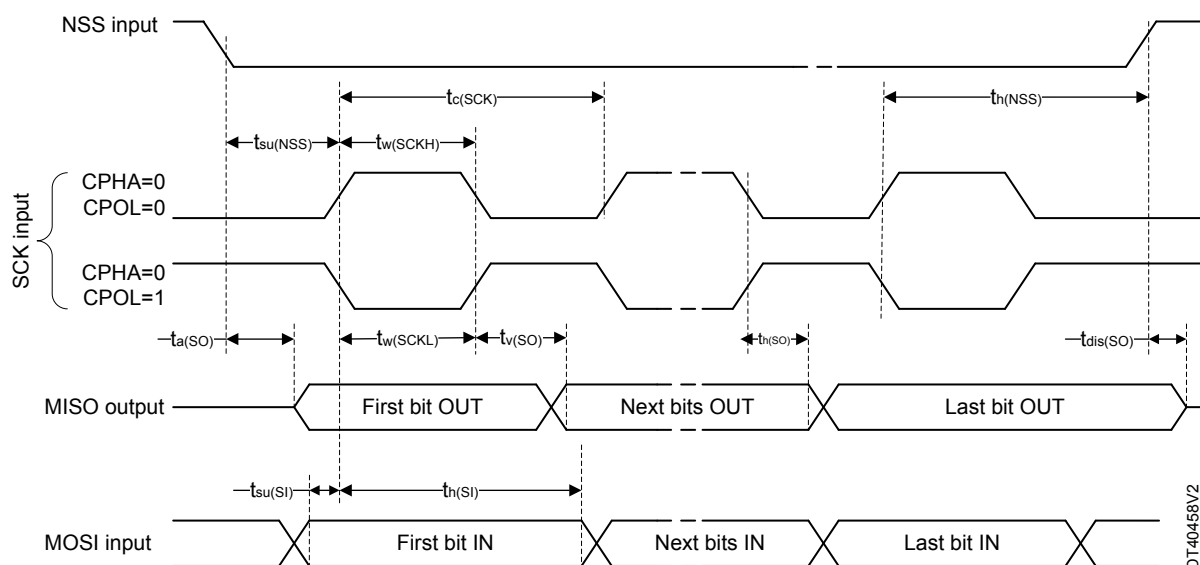

DT40458V2

Figure 38. SPI timing diagram - slave mode and CPHA = 1

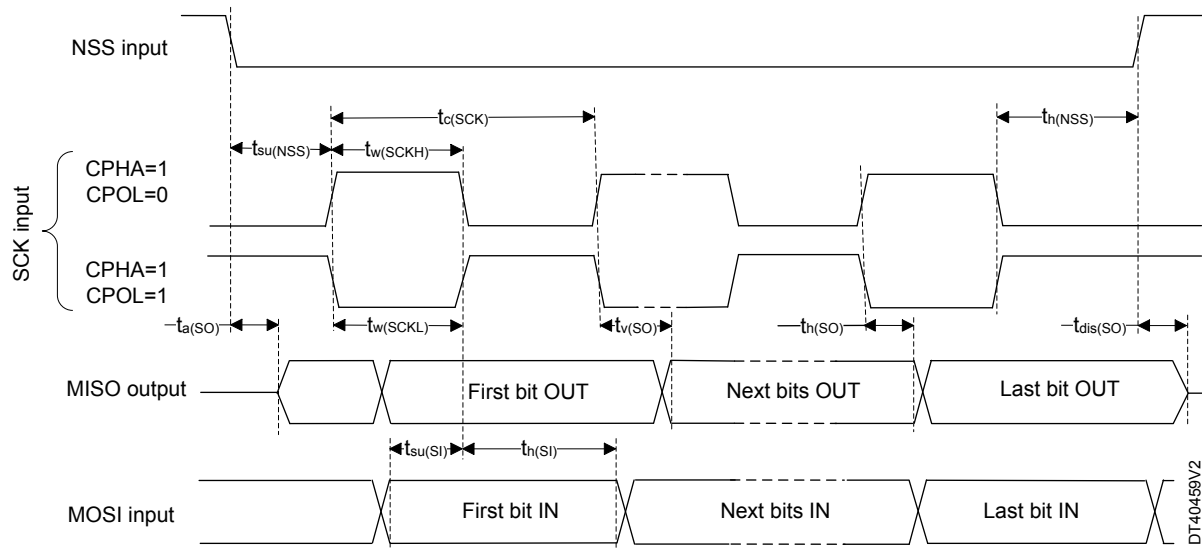

DT140469V2

Note: Measurement points are done at 0.3 V_{DD} and 0.7 V_{DD} levels.

Figure 39. SPI timing diagram - master mode

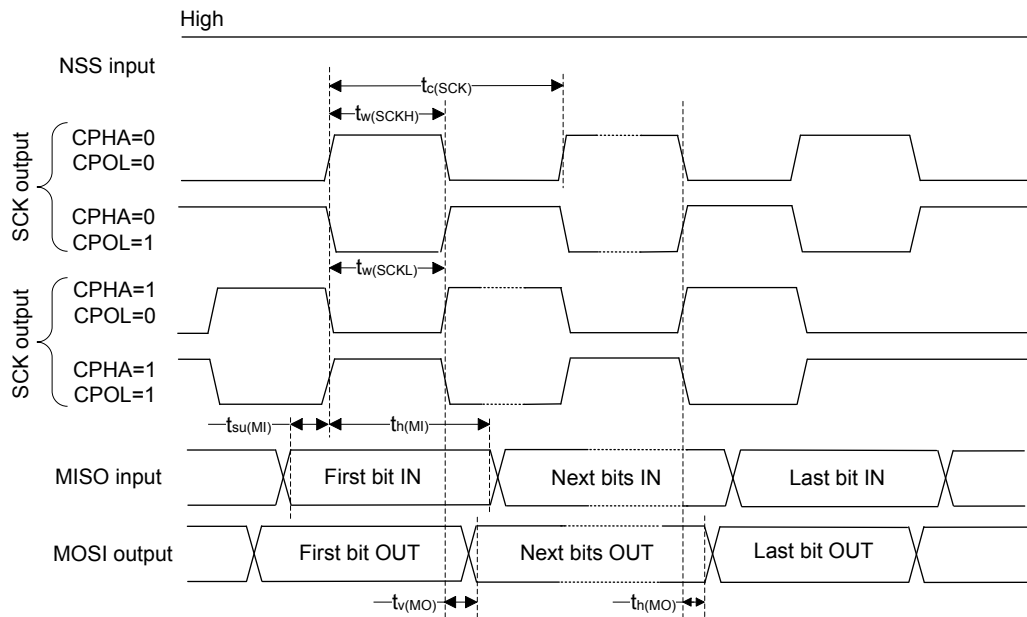

DT14136V4

Note: Measurement points are done at 0.3 V_{DD} and 0.7 V_{DD} levels.

5.3.28 USB_FS characteristics

Table 71. USB_FS characteristics

Symbol	Parameter	Conditions	Min	Typ	Max	Unit
V _{DDUSB}	USB transceiver operating supply voltage	-	3.0 ⁽¹⁾	-	3.6	V
R _{PUI}	Embedded USB_DP pullup value during idle	-	900	-	1575	Ω
R _{PUR}	Embedded USB_DP pullup value during reception	-	1425	-	3090	
Z _{DRV}	Output driver impedance ⁽²⁾	High and low driver	28	36	44	

1. USB functionality is ensured down to 2.7 V, but some USB electrical characteristics are degraded in 2.7 to 3.0 V range.
2. No external termination series resistors are required on USB_DP (D+) and USB_DM (D-). The matching impedance is already included in the embedded driver.

5.3.29 Ethernet interface characteristics

Unless otherwise specified, the parameters given in the following Tables are derived from tests performed under the ambient temperature, frcc_c_ck frequency, and V_{DD} supply voltage conditions summarized in Table 18. General operating conditions, with the following configuration:

- Output speed is set to OSPEEDRy[1:0] = 10
- Capacitive load Cl = 20 pF
- Measurements points are done at CMOS levels : 0.5 V_{DD}
- IO compensation cell activated

Table 72. Dynamic characteristics: Ethernet MAC signals for SMI

Evaluated by characterization - Not tested in production.

Symbol	Parameter	Min	Typ	Max	Unit
t _{MDC}	MDC cycle time(2.5 MHz)	399	400	401	ns
T _{d(MDIO)}	Write data valid time	0.5	1	1.5	
t _{su(MDIO)}	Read data setup time	14.5	-	-	
t _{h(MDIO)}	Read data hold time	0	-	-	

Table 73. Dynamic characteristics: Ethernet MAC signals for RMII

Evaluated by characterization - Not tested in production.

Symbol	Parameter	Min	Typ	Max	Unit
t _{su(RXD)}	Receive data setup time	2	-	-	ns
t _{ih(RXD)}	Receive data hold time	1	-	-	
t _{su(CRS)}	Carrier sense setup time	1.5	-	-	
t _{ih(CRS)}	Carrier sense hold time	1	-	-	
t _{d(TXEN)}	Transmit enable valid delay time	7.5	9.5	14	
t _{d(TXD)}	Transmit data valid delay time	7.5	10	15.5	

Table 74. Dynamic characteristics: Ethernet MAC signals for MII

Symbol	Parameter	Min	Typ	Max	Unit
t _{su(RXD)}	Receive data setup time	1.5	-	-	ns
t _{ih(RXD)}	Receive data hold time	1.5	-	-	
t _{su(DV)}	Data valid setup time	1.5	-	-	

Symbol	Parameter	Min	Typ	Max	Unit
$t_{ih}(DV)$	Data valid hold time	1	-	-	ns
$t_{su}(ER)$	Error setup time	1.5	-	-	
$t_{ih}(ER)$	Error hold time	1.5	-	-	
$t_d(TXEN)$	Transmit enable valid delay time	7.5	9.5	14	
$t_d(TXD)$	Transmit data valid delay time	7	10.5	16	

Figure 40. RMII timing diagram

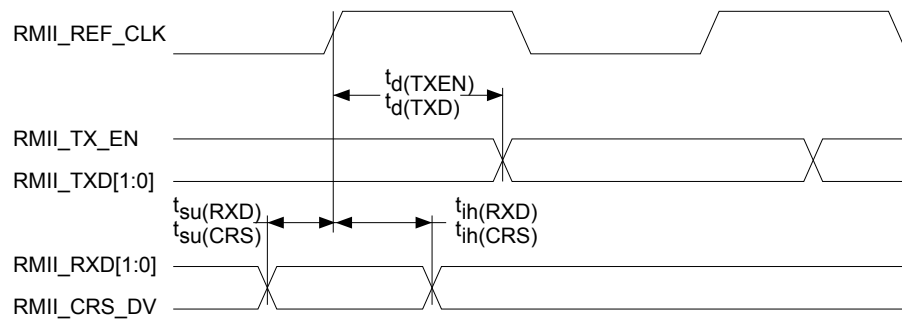

DT15667V1

Figure 41. MII timing diagram

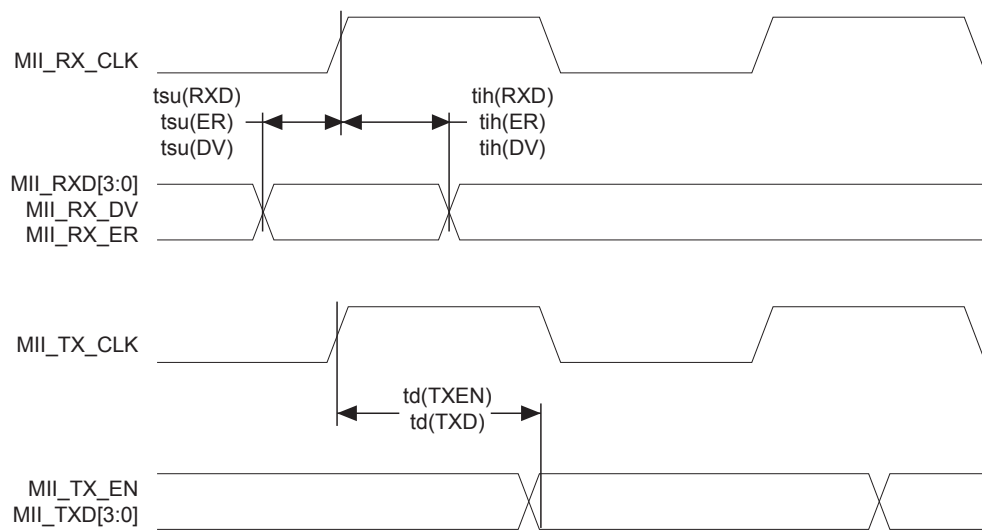

DT15668V1

Figure 42. SMI timing diagram

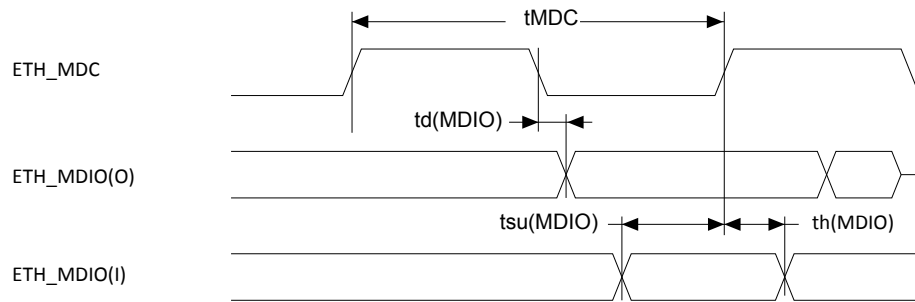

DT31384V1

5.3.30 JTAG/SWD interface characteristics

Unless otherwise specified, the parameters given in Table 75 and Table 76 are derived from tests performed under the ambient temperature, f_{HCLKx} frequency and V_{DD} supply voltage conditions summarized in Table 18, with the following configuration:

- Output speed set to OSPEEDRy[1:0] = 10
- Capacitive load $C_L = 30$ pF
- Measurement points done at $0.5 \times V_{DD}$ level

Refer to Table 48. I/O static characteristics for more details on the input/output characteristics.

Table 75. JTAG characteristics

Evaluated by characterization - Not tested in production.

Symbol	Parameter	Min	Typ	Max	Unit
F_{TCK}	TCK clock frequency	-	-	34	MHz
$t_{su}(TMS)$	TMS input setup time	2	-	-	ns
$t_{h}(TMS)$	TMS input hold time	0.5	-	-	
$t_{su}(TDI)$	TDI input setup time	1.5	-	-	
$t_{h}(TDI)$	TDI input hold time	0.5	-	-	
$t_{ov}(TDO)$	TDO output valid time	-	11	14.5	
$t_{oh}(TDO)$	TDO output hold time	7.5	-	-	

Figure 43. JTAG timing diagram

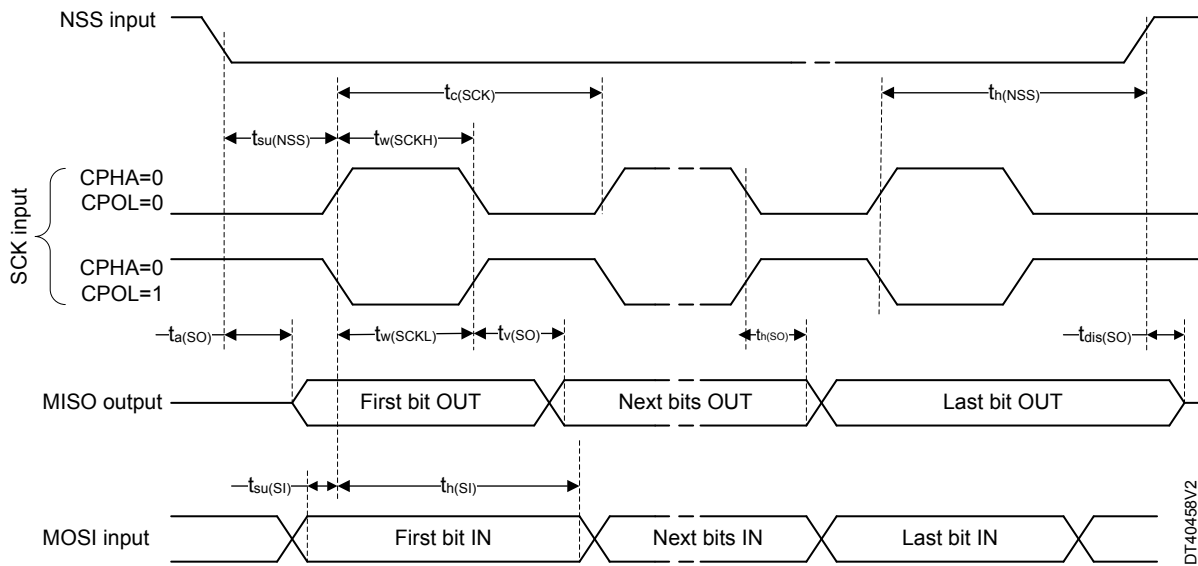
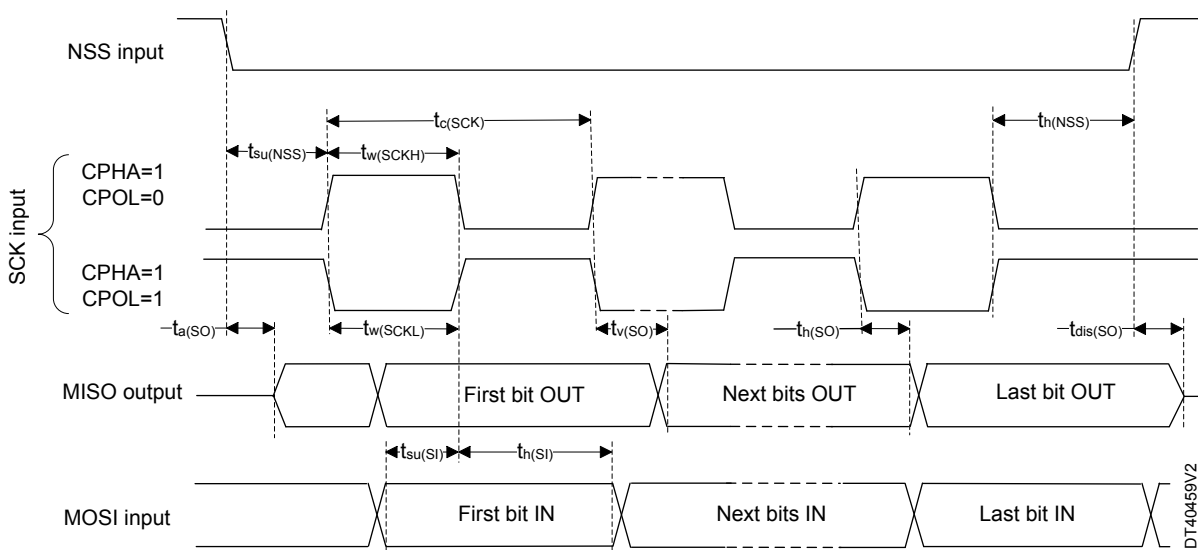

Table 76. SWD characteristics

Evaluated by characterization - Not tested in production.

Symbol	Parameter	Min	Typ	Max	Unit
F_{SWCLK}	SWCLK clock frequency	-	-	71	MHz
$t_{su(SWDIO)}$	SWDIO input setup time	3	-	-	ns
$t_{h(SWDIO)}$	SWDIO input hold time	0.5	-	-	
$t_{ov(SWDIO)}$	SWDIO output valid time	-	11.5	14	
$t_{oh(SWDIO)}$	SWDIO output hold time	9.5	-	-	

Figure 44. SWD timing diagram



6 Package information

To meet environmental requirements, ST offers these devices in different grades of **ECOPACK** packages, depending on their level of environmental compliance. ECOPACK specifications, grade definitions and product status are available at: www.st.com. ECOPACK is an ST trademark.

6.1 Device marking

Refer to technical note "Reference device marking schematics for STM32 microcontrollers and microprocessors" (TN1433) available on www.st.com, for the location of pin 1 / ball A1 as well as the location and orientation of the marking areas versus pin 1 / ball A1.

Parts marked as "ES", "E" or accompanied by an engineering sample notification letter, are not yet qualified and therefore not approved for use in production. ST is not responsible for any consequences resulting from such use. In no event will ST be liable for the customer using any of these engineering samples in production. ST's Quality department must be contacted prior to any decision to use these engineering samples to run a qualification activity.

A WLCSP simplified marking example (if any) is provided in the corresponding package information subsection.

6.2 LQFP32 package information (5V)

This LQFP is a 32-pin, 7 x 7 mm, low-profile quad flat package.

Note: *Figure 45 is not to scale.*

Refer to the notes section for the list of notes on *Figure 45* and *Table 77*.

Figure 45. LQFP32- Outline

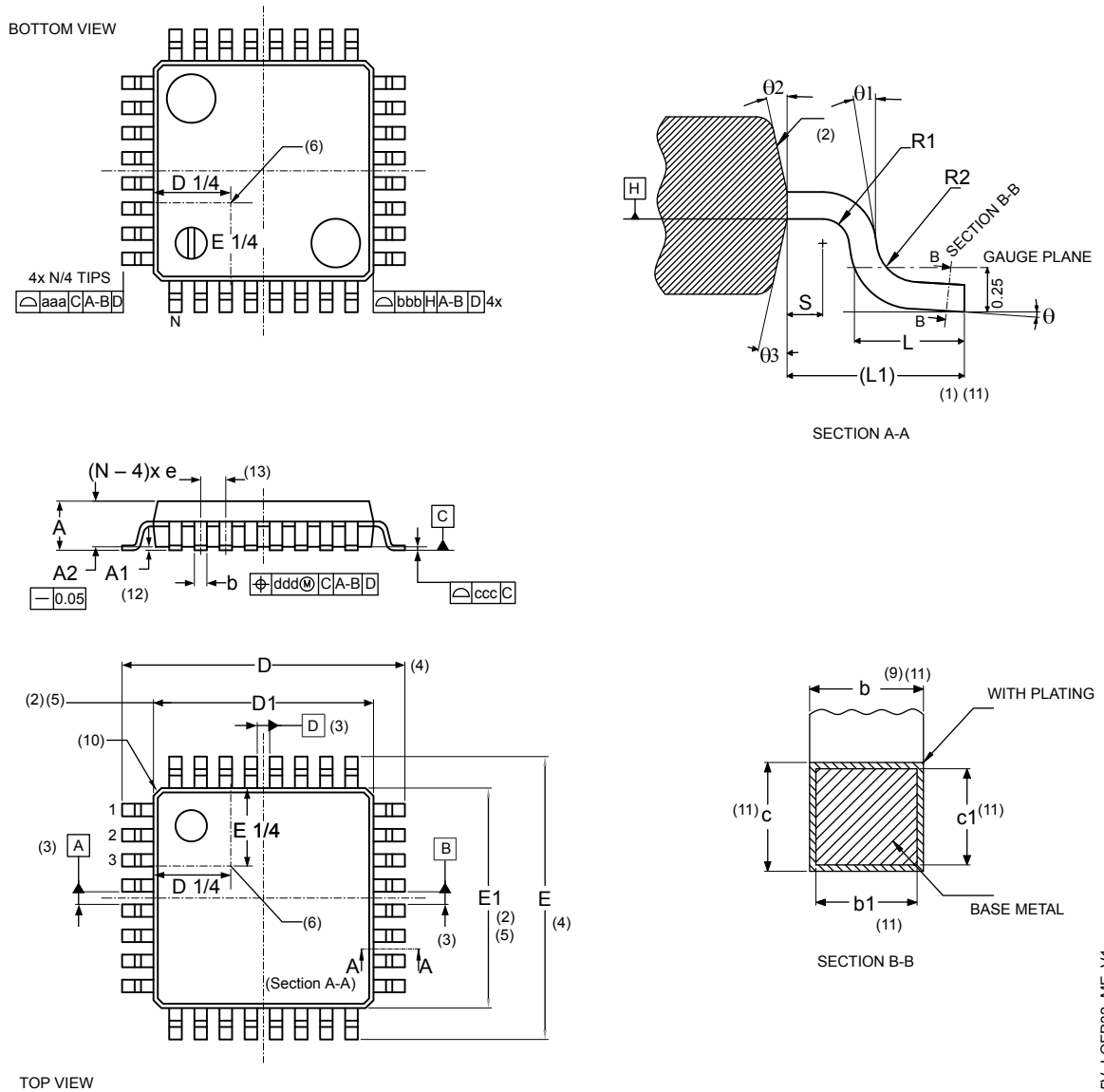

5V_LQFP32_ME_V1

Table 77. LQFP32 - Mechanical data

Symbol	Millimeters			Inches ^(14.)		
	Min	Typ	Max	Min	Typ	Max
θ	0°	3.5°	7°	0°	3.5°	7°
θ_1	0°	-	-	0°	-	-
θ_2	10°	12°	14°	10°	12°	14°
θ_3	10°	12°	14°	10°	12°	14°
A	-	-	1.60	-	-	0.0630
A1 ^(12.)	0.05	-	0.15	0.0020	-	0.0059
A2	1.35	1.40	1.45	0.0531	0.0551	0.0571
b ^(9.) (11.)	0.30	0.37	0.45	0.0118	0.0146	0.0177
b1 ^(11.)	0.30	0.35	0.40	0.0118	0.0128	0.0157
c ^(11.)	0.09	-	0.20	0.0035	-	0.0079
c1 ^(11.)	0.09	-	0.16	0.0035	-	0.0063
D ^(4.)	9.00 BSC			0.3543 BSC		
D1 ^(2.) (5.)	7.00 BSC			0.2756 BSC		
e	0.80 BSC			0.0315 BSC		
E ^(4.)	9.00 BSC			0.3543 BSC		
E1 ^(2.) (5.)	7.00 BSC			0.2756 BSC		
L	0.45	0.60	0.75	0.0177	0.0236	0.0295
L1	1.00 REF			0.0394 REF		
N ^(13.)	32			32		
R1	0.08	-	-	0.0031	-	-
R2	0.08	-	0.20	0.0031	-	0.0079
S	0.20	-	-	0.0079	-	-
aaa ^(1.) (7.)(15.)	0.20			0.0079		
bbb ^(1.) (7.)(15.)	0.20			0.0079		
ccc ^(1.) (7.)(15.)	0.10			0.0039		
ddd ^(1.) (7.)(15.)	0.20			0.0079		

Notes:

1. Dimensioning and tolerancing schemes conform to ASME Y14.5M-1994.
2. The top package body size may be smaller than the bottom package size by as much as 0.15 mm.
3. Datums A-B and D to be determined at datum plane H.
4. To be determined at the seating datum plane C.
5. Dimensions D1 and E1 do not include mold flash or protrusions. Allowable mold flash or protrusions is "0.25 mm" per side. D1 and E1 are maximum plastic body size dimensions including mold mismatch.
6. Details of pin 1 identifier are optional but must be located within the zone indicated.
7. All dimensions are in millimeters.
8. No intrusion is allowed inwards the leads.
9. Dimension b does not include a dambar protrusion. Allowable dambar protrusion shall not cause the lead width to exceed the maximum "b" dimension by more than 0.08 mm. Dambar cannot be located on the lower radius or the foot. The minimum space between the protrusion and an adjacent lead is 0.07 mm for 0.4 mm and 0.5 mm pitch packages.
10. The exact shape of each corner is optional.
11. These dimensions apply to the flat section of the lead between 0.10 mm and 0.25 mm from the lead tip.
12. A1 is defined as the distance from the seating plane to the lowest point on the package body.
13. N is the number of terminal positions for the specified body size.
14. Values in inches are converted from mm and rounded to four decimal digits.
15. Recommended values and tolerances.

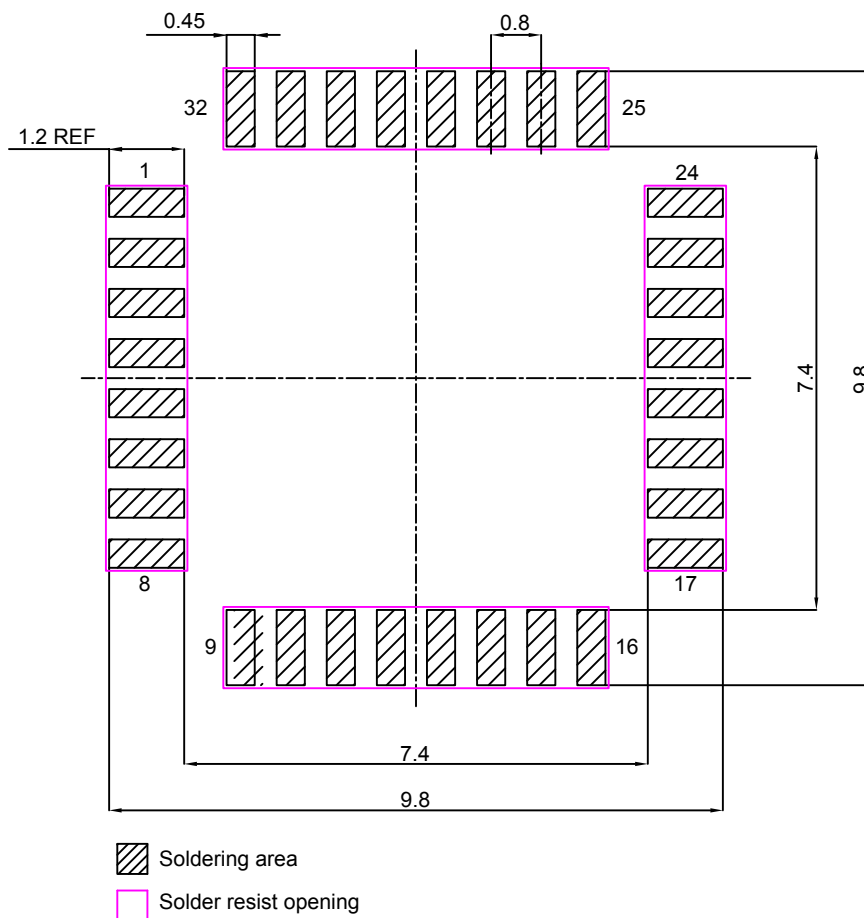
Figure 46. LQFP32 - Footprint example

1. Dimensions are expressed in millimeters.

6.3 UFQFPN32 package information (A0B8)

This UFQFPN is a 32-pin, 5 x 5 mm, 0.5 mm pitch ultra-thin fine pitch quad flat package.

Figure 47. UFQFPN32 - Outline

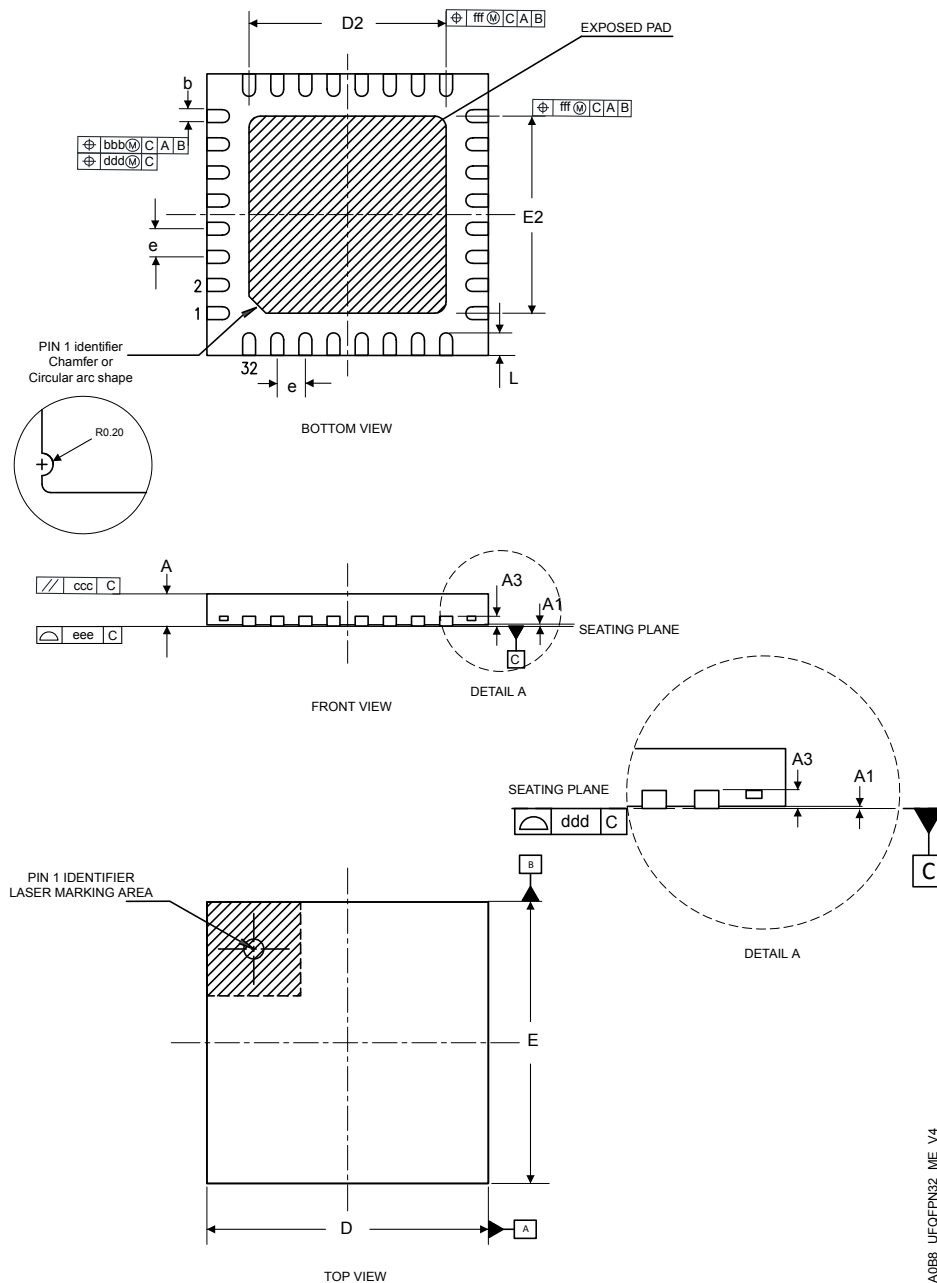

A0B8_UFQFPN32_ME_V4

1. Drawing is not to scale.
2. All leads/pads should also be soldered to the PCB to improve the lead/pad solder joint life.
3. There is an exposed die pad on the underside of the UFQFPN package. It is recommended to connect and solder this backside pad to PCB ground.

Table 78. UFQFPN32 - Mechanical data

Symbol	Millimeters ⁽¹⁾			Inches ⁽²⁾		
	Min	Typ	Max	Min	Typ	Max
A ⁽³⁾⁽⁴⁾	0.50	0.55	0.60	0.0197	0.0217	0.0236
A1 ⁽⁵⁾	0.00	-	0.05	0.000	-	0.0020
A3 ⁽⁶⁾	-	0.15	-	-	0.0060	-
b ⁽⁷⁾	0.18	0.25	0.30	0.0071	0.010	0.0118
D ⁽⁸⁾⁽⁹⁾	5.00 BSC			0.1969 BSC		
D2	3.50	3.60	3.70	0.139	0.143	0.147
E ⁽⁸⁾⁽⁹⁾	5.00 BSC			0.1969 BSC		
E2	3.50	3.60	3.70	0.139	0.143	0.147
e ⁽⁹⁾	-	0.50	-	-	0.02	-
N ⁽¹⁰⁾				32		
K	0.15	-	-	0.006	-	-
L	0.30	-	0.50	0.0119	-	0.0199
R	0.09	-	-	0.004	-	-

1. All dimensions are in millimeters. Dimensioning and tolerancing schemes are conform to ASME Y14.5M-2018 except European .
2. Values in inches are converted from mm and rounded to 4 decimal digits.
3. UFQFPN stands for Ultra thin Fine pitch Quad Flat Package No lead: $A \leq 0.60\text{mm}$ / Fine pitch $e \leq 1.00\text{mm}$.
4. The profile height, A, is the distance from the seating plane to the highest point on the package. It is measured perpendicular to the seating plane.
5. A1 is the vertical distance from the bottom surface of the plastic body to the nearest metallized package feature.
6. A3 is the distance from the seating plane to the upper surface of the terminals.
7. Dimension b applies to metallized terminal. If the terminal has the optional radius on the other end of the terminal, the dimension b must not be measured in that radius area.
8. Dimensions D and E do not include mold protrusion, not to exceed 0,15mm.
9. BSC stands for BASIC dimensions. It corresponds to the nominal value and has no tolerance. For tolerances refer to Table 79
10. N represents the total number of terminals.

Table 79. Tolerance of form and position

Symbol ⁽¹⁾	Tolerance of form and position ⁽²⁾	Tolerance of form and position ⁽³⁾
	In millimeters	In inches
aaa	0.15	0.006
bbb	0.10	0.004
ccc	0.10	0.004
ddd	0.05	0.002
eee	0.10	0.004
fff	0.10	0.004

1. For the tolerance of form and position definitions see Table 80.
2. All dimensions are in millimetres. Dimensioning and tolerancing schemes are conform to ASME Y14.5M-2018 except European .
3. Values in inches are converted from mm and rounded to 4 decimal digits.

6.4 LQFP48 package information (5B)

This LQFP is a 48-pins, 7 x 7 mm, low-profile quad flat package.

Note: See list of notes in the notes section.

Figure 49. LQFP48- Outline⁽¹⁵⁾

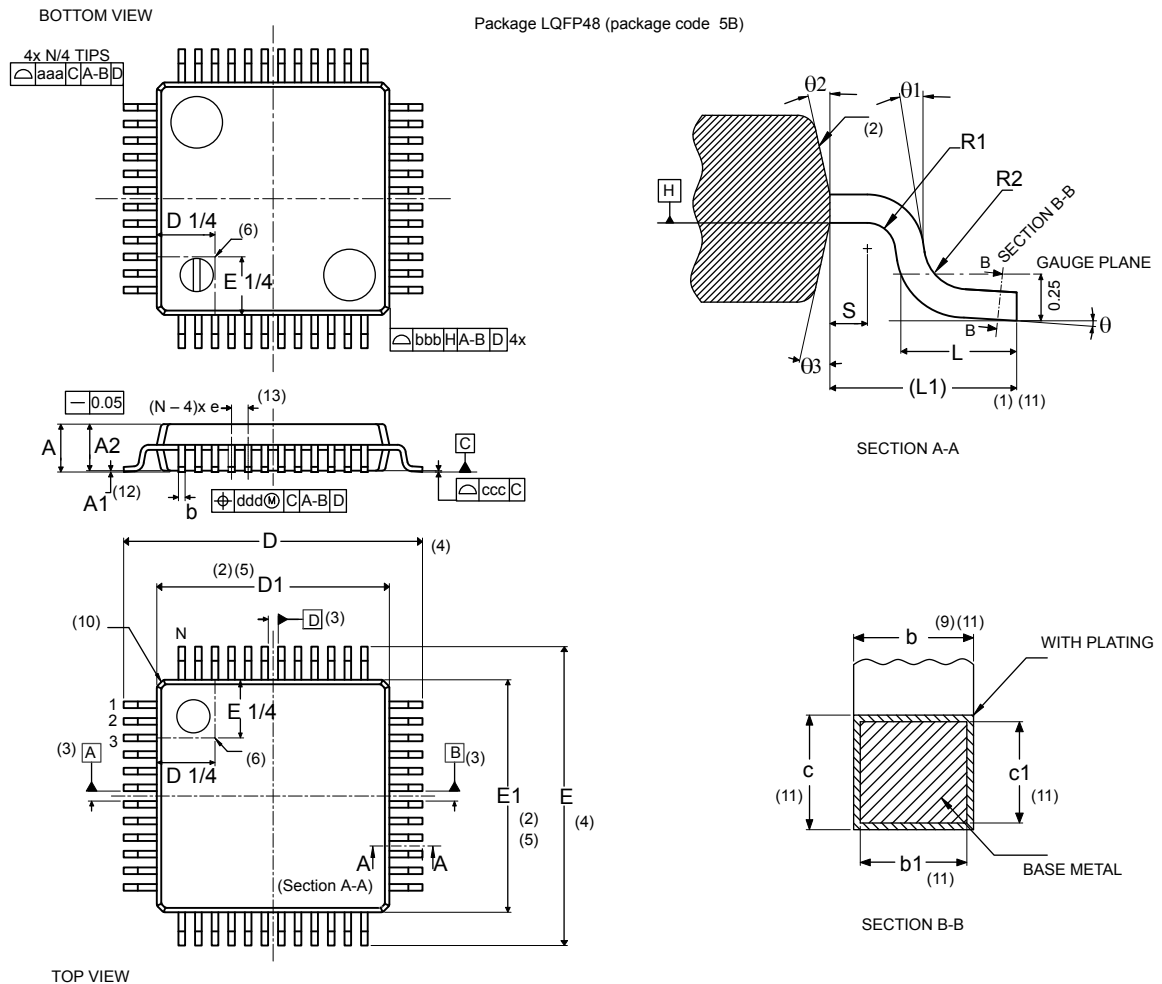

Table 81. LQFP48 - Mechanical data

Symbol	millimeters			inches ^(14.)		
	Min	Typ	Max	Min	Typ	Max
A	-	-	1.60	-	-	0.0630
A1 ^(12.)	0.05	-	0.15	0.0020	-	0.0059
A2	1.35	1.40	1.45	0.0531	0.0551	0.0571
b ^(9.) (11.)	0.17	0.22	0.27	0.0067	0.0087	0.0106
b1 ^(11.)	0.17	0.20	0.23	0.0067	0.0079	0.0090
c ^(11.)	0.09	-	0.20	0.0035	-	0.0079
c1 ^(11.)	0.09	-	0.16	0.0035	-	0.0063
D ^(4.)	9.00 BSC			0.3543 BSC		
D1 ^(4.) (5.)	7.00 BSC			0.2756 BSC		
E ^(4.)	9.00 BSC			0.3543 BSC		
E1 ^(4.) (5.)	7.00 BSC			0.2756 BSC		
e	0.50 BSC			0.1970 BSC		
L	0.45	0.60	0.75	0.0177	0.0236	0.0295
L1	1.00 REF			0.0394 REF		
N ^(13.)	48					
θ	0°	3.5°	7°	0°	3.5°	7°
θ1	0°	-	-	0°	-	-
θ2	10°	12°	14°	10°	12°	14°
θ3	10°	12°	14°	10°	12°	14°
R1	0.08	-	-	0.0031	-	-
R2	0.08	-	0.20	0.0031	-	0.0079
S	0.20	-	-	0.0079	-	-
aaa ^(1.) (7.)	0.20			0.0079		
bbb ^(1.) (7.)	0.20			0.0079		
ccc ^(1.) (7.)	0.08			0.0031		
ddd ^(1.) (7.)	0.08			0.0031		

Notes:

1. Dimensioning and tolerancing schemes conform to ASME Y14.5M-1994.
2. The Top package body size may be smaller than the bottom package size by as much as 0.15 mm.
3. Datums A-B and D to be determined at datum plane H.
4. To be determined at seating datum plane C.
5. Dimensions D1 and E1 do not include mold flash or protrusions. Allowable mold flash or protrusions is "0.25 mm" per side. D1 and E1 are Maximum plastic body size dimensions including mold mismatch.
6. Details of pin 1 identifier are optional but must be located within the zone indicated.
7. All Dimensions are in millimeters.
8. No intrusion allowed inwards the leads.
9. Dimension "b" does not include dambar protrusion. Allowable dambar protrusion shall not cause the lead width to exceed the maximum "b" dimension by more than 0.08 mm. Dambar cannot be located on the lower radius or the foot. Minimum space between protrusion and an adjacent lead is 0.07 mm for 0.4 mm and 0.5 mm pitch packages.

10. Exact shape of each corner is optional.
11. These dimensions apply to the flat section of the lead between 0.10 mm and 0.25 mm from the lead tip.
12. A1 is defined as the distance from the seating plane to the lowest point on the package body.
13. "N" is the number of terminal positions for the specified body size.
14. Values in inches are converted from mm and rounded to 4 decimal digits
15. Drawing is not to scale.

Figure 50. LQFP48 - Footprint example

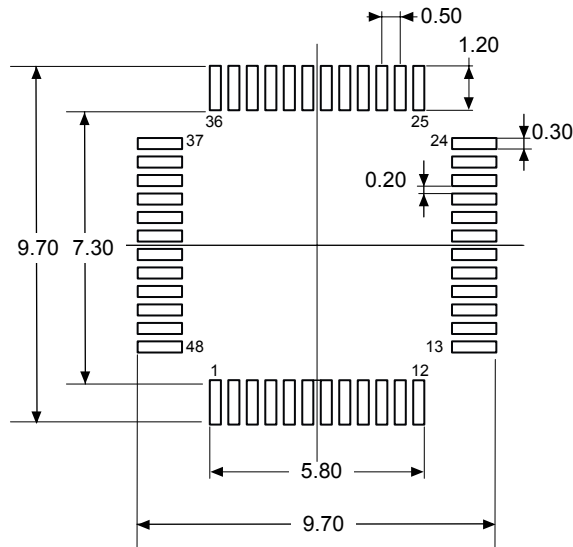

1. Dimensions are expressed in millimeters.

6.5 UFQFPN48 package information (A0B9)

This UFQFPN is a 48-lead, 7 x 7 mm, 0.5 mm pitch, ultra thin fine pitch quad flat package.

Figure 51. UFQFPN48 - Outline

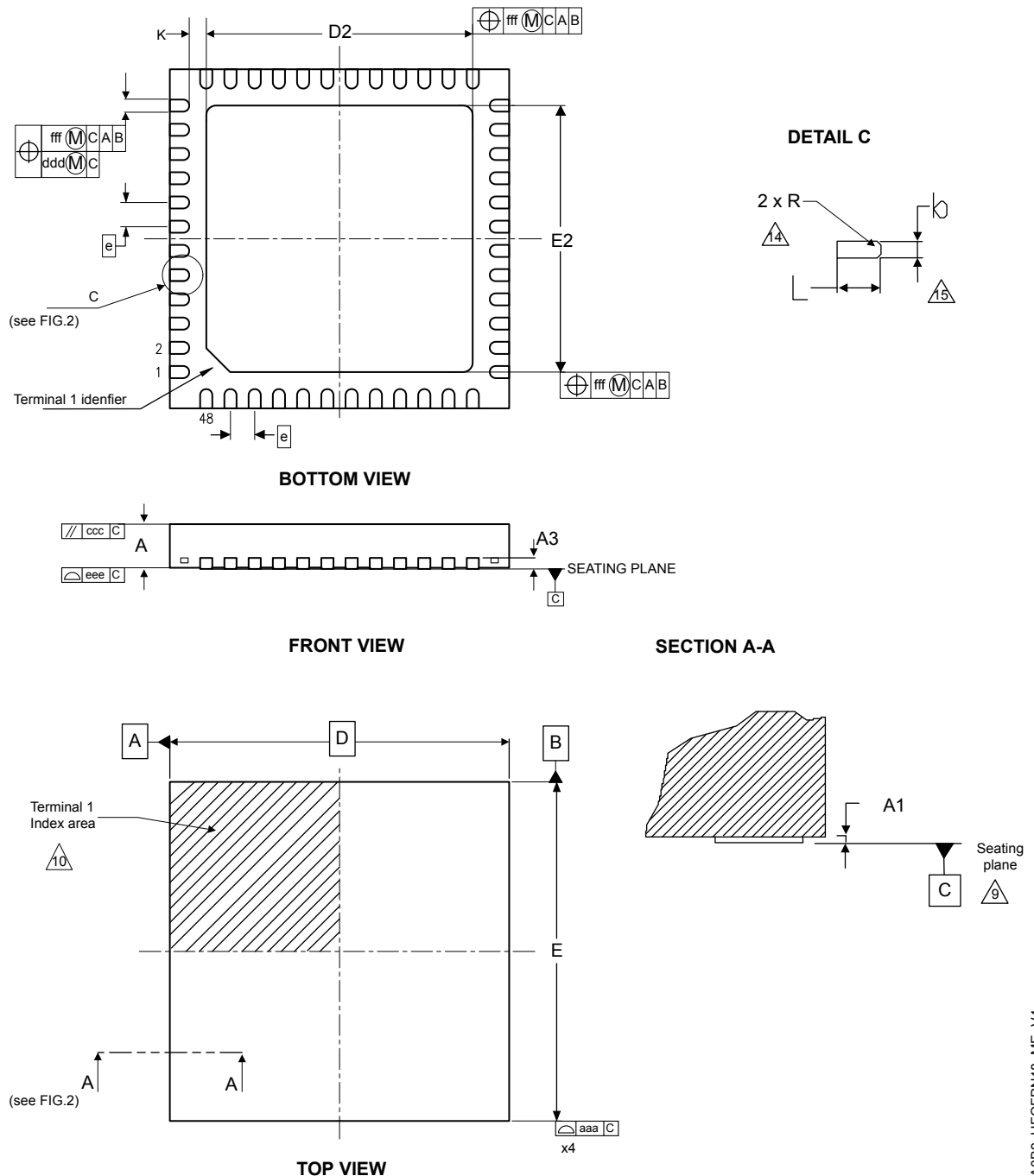

1. Drawing is not to scale.
2. All leads/pads should also be soldered to the PCB to improve the lead/pad solder joint life.
3. There is an exposed die pad on the under side of the UFQFPN48 package. It is recommended to connect and solder this back-side pad to PCB ground.

DT_A0B9_UFQFPN48_ME_V4

Table 82. UFQFPN48 - Mechanical data

Symbol	Millimeters			Inches ⁽¹⁾		
	Min	Typ	Max	Min	Typ	Max
A	0.50	0.55	0.60	0.0197	0.0217	0.0236
A1	0.00	-	0.05	0.0000	-	0.0020
b	0.18	0.25	0.30	0.0071	0.0098	0.0118
D ⁽²⁾	7.00 BSC			0.2756 BSC		
D2 ⁽³⁾	5.50	5.60	5.70	0.2165	0.2205	0.2244
E ⁽²⁾	7.00 BSC			0.2756 BSC		
E2 ⁽³⁾	5.50	5.60	5.70	0.2165	0.2205	0.2244
e	0.50 BSC			0.0197 BSC		
N	48					
L	0.30	-	0.50	0.0118	-	0.0197
R	0.10	-	-	0.0039	-	-
aaa	0.15			0.0059		
bbb	0.10			0.0039		
ccc	0.10			0.0039		
ddd	0.05			0.0020		
eee	0.08			0.0031		
fff	0.10			0.0039		

1. Values in inches are converted from mm and rounded to four decimal digits.
2. Dimensions D and E do not include mold protrusion, not exceed 0.15 mm.
3. Dimensions D2 and E2 are not in accordance with JEDEC.

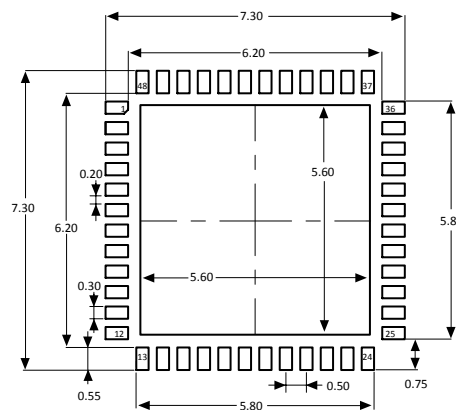
Figure 52. UFQFPN48 - Footprint example

1. Dimensions are expressed in millimeters.

6.6 LQFP64 package information (5W)

This is a 64-pin, 10 x 10 mm low-profile quad flat package.

Figure 53. LQFP64 - Outline^(15.)

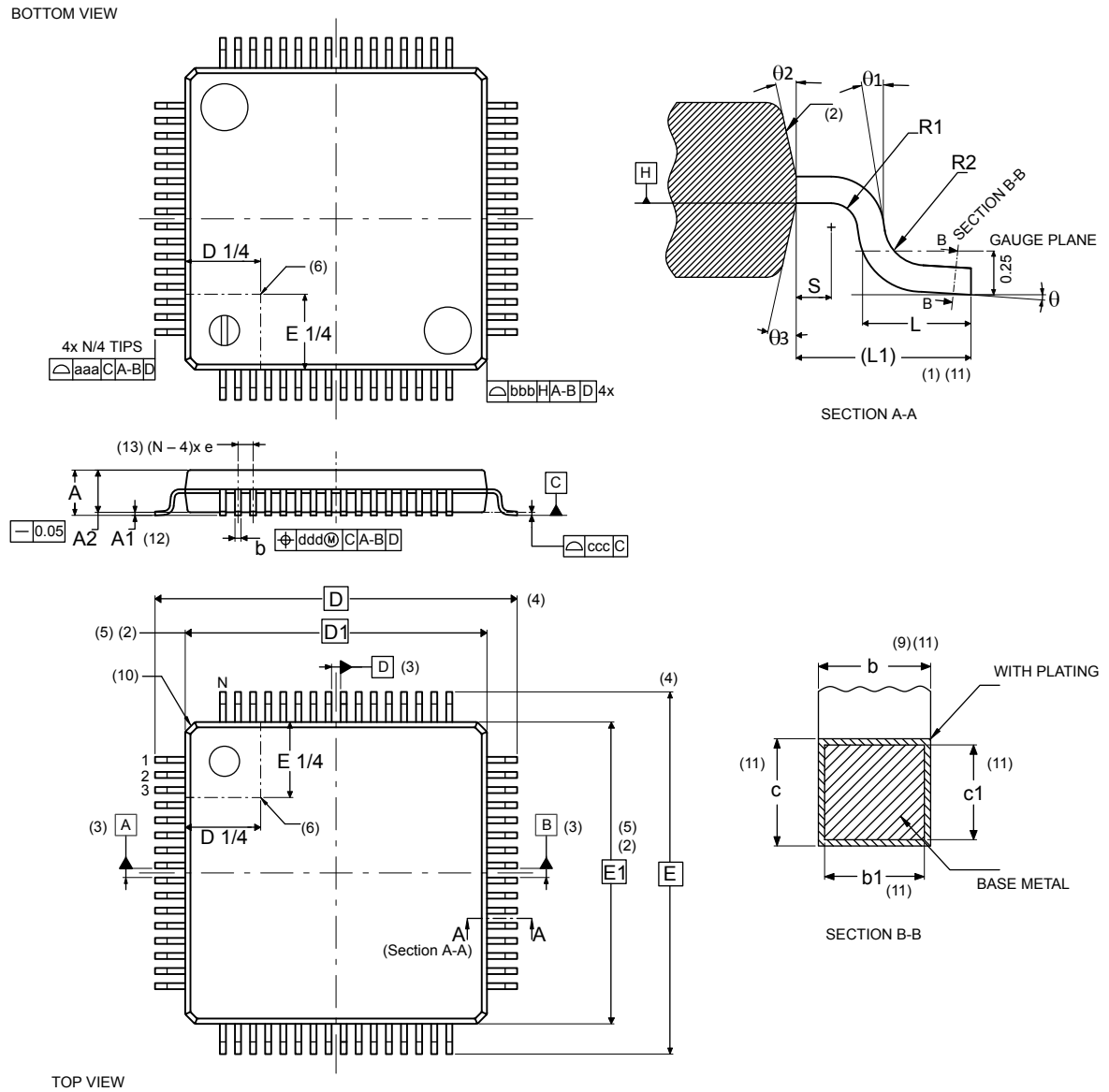

5W_LQFP64_ME_V1

Table 83. LQFP64 - Mechanical data

Symbol	millimeters			inches ⁽¹⁴⁾		
	Min	Typ	Max	Min	Typ	Max
A	-	-	1.60	-	-	0.0630
A1 ⁽¹²⁾	0.05	-	0.15	0.0020	-	0.0059
A2	1.35	1.40	1.45	0.0531	0.0551	0.0571
b ⁽⁹⁾ (11.)	0.17	0.22	0.27	0.0067	0.0087	0.0106
b1 ^(11.)	0.17	0.20	0.23	0.0067	0.0079	0.0091
c ^(11.)	0.09	-	0.20	0.0035	-	0.0079
c1 ^(11.)	0.09	-	0.16	0.0035	-	0.0063
D ⁽⁴⁾	12.00 BSC			0.4724 BSC		
D1 ⁽²⁾ (5.)	10.00 BSC			0.3937 BSC		
E ⁽⁴⁾	12.00 BSC			0.4724 BSC		
E1 ⁽²⁾ (5.)	10.00 BSC			0.3937 BSC		
e	0.50 BSC			0.0197 BSC		
L	0.45	0.60	0.75	0.0177	0.0236	0.0295
L1	1.00 REF			0.0394 REF		
N ^(13.)	64					
Θ	0°	3.5°	7°	0°	3.5°	7°
Θ1	0°	-	-	0°	-	-
Θ2	10°	12°	14°	10°	12°	14°
Θ3	10°	12°	14°	10°	12°	14°
R1	0.08	-	-	0.0031	-	-
R2	0.08	-	0.20	0.0031	-	0.0079
S	0.20	-	-	0.0079	-	-
aaa ^(1.)	0.20			0.0079		
bbb ^(1.)	0.20			0.0079		
ccc ^(1.)	0.08			0.0031		
ddd ^(1.)	0.08			0.0031		

Notes

1. Dimensioning and tolerancing schemes conform to ASME Y14.5M-1994.
2. The top package body size may be smaller than the bottom package size by as much as 0.15 mm.
3. Datums A-B and D to be determined at datum plane H.
4. To be determined at seating datum plane C.
5. Dimensions D1 and E1 do not include mold flash or protrusions. Allowable mold flash or protrusions is "0.25 mm" per side. D1 and E1 are Maximum plastic body size dimensions including mold mismatch.
6. Details of pin 1 identifier are optional but must be located within the zone indicated.
7. All dimensions are in millimeters.
8. No intrusion allowed inwards the leads.
9. Dimension "b" does not include dambar protrusion. Allowable dambar protrusion shall not cause the lead width to exceed the maximum "b" dimension by more than 0.08 mm. Dambar cannot be located on the lower radius or the foot. Minimum space between protrusion and an adjacent lead is 0.07 mm for 0.4 mm and 0.5 mm pitch packages.
10. Exact shape of each corner is optional.
11. These dimensions apply to the flat section of the lead between 0.10 mm and 0.25 mm from the lead tip.
12. A1 is defined as the distance from the seating plane to the lowest point on the package body.
13. N is the number of terminal positions for the specified body size.
14. Values in inches are converted from mm and rounded to 4 decimal digits.
15. Drawing is not to scale.

Table 84. LQFP80 - Mechanical data

Symbol	millimeters			inches ⁽¹⁴⁾		
	Min	Typ	Max	Min	Typ	Max
A	-	-	1.60	-	-	0.0630
A1 ^(12.)	0.05	-	0.15	0.0020	-	0.0059
A2	1.35	1.40	1.45	0.0531	0.0551	0.0571
b ^(9.) (11.)	0.17	0.22	0.27	0.0067	0.0087	0.0106
b1 ^(11.)	0.17	0.20	0.23	0.0067	0.0079	0.0091
c ^(11.)	0.09	-	0.20	0.0035	-	0.0079
c1 ^(11.)	0.09	-	0.16	0.0035	-	0.0063
D ^(4.)	14.00 BSC			0.5512 BSC		
D1 ^(2.) (5.)	12.00 BSC			0.4724 BSC		
E ^(4.)	14.00 BSC			0.5512 BSC		
E1 ^(2.) (5.)	12.00 BSC			0.4724 BSC		
e	0.50 BSC			0.0197 BSC		
L	0.45	0.60	0.75	0.0177	0.0236	0.0295
L1	-	1.00	-	-	0.0394	-
N ^(13.)	80					
Θ	0°	3.5°	7°	0°	3.5°	7°
Θ1	0°	-	-	0°	-	-
Θ2	10°	12°	14°	10°	12°	14°
Θ3	10°	12°	14°	10°	12°	14°
R1	0.08	-	-	0.0031	-	-
R2	0.08	-	0.20	0.0031	-	0.0079
S	0.20	-	-	0.0079	-	-
aaa ^(1.)	0.20			0.0079		
bbb ^(1.)	0.20			0.0079		
ccc ^(1.)	0.08			0.0031		
ddd ^(1.)	0.08			0.0031		

Notes

1. Dimensioning and tolerancing schemes conform to ASME Y14.5M-1994.
2. The top package body size may be smaller than the bottom package size by as much as 0.15 mm.
3. Datums A-B and D to be determined at datum plane H.
4. To be determined at seating datum plane C.
5. Dimensions D1 and E1 do not include mold flash or protrusions. Allowable mold flash or protrusions is "0.25 mm" per side. D1 and E1 are Maximum plastic body size dimensions including mold mismatch.
6. Details of pin 1 identifier are optional but must be located within the zone indicated.
7. All dimensions are in millimeters.
8. No intrusion allowed inwards the leads.
9. Dimension "b" does not include dambar protrusion. Allowable dambar protrusion shall not cause the lead width to exceed the maximum "b" dimension by more than 0.08 mm. Dambar cannot be located on the lower radius or the foot. Minimum space between protrusion and an adjacent lead is 0.07 mm for 0.4 mm and 0.5 mm pitch packages.
10. Exact shape of each corner is optional.
11. These dimensions apply to the flat section of the lead between 0.10 mm and 0.25 mm from the lead tip.
12. A1 is defined as the distance from the seating plane to the lowest point on the package body.
13. "N" is the number of terminal positions for the specified body size.
14. Values in inches are converted from mm and rounded to 4 decimal digits.
15. Drawing is not to scale.

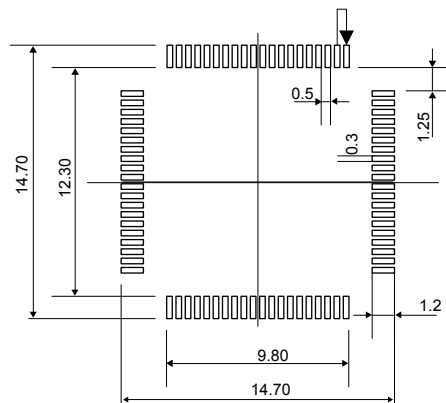
Figure 55. LQFP80 - Footprint example

9X_LQFP80_FP_V1

1. Dimensions are expressed in millimeters.

6.8 LQFP100 package information (1L)

This LQFP is a 100-pin, 14 x 14 mm, low-profile quad flat package.

Note: See list of notes in the notes section.

Figure 56. LQFP100 - Outline⁽¹⁵⁾

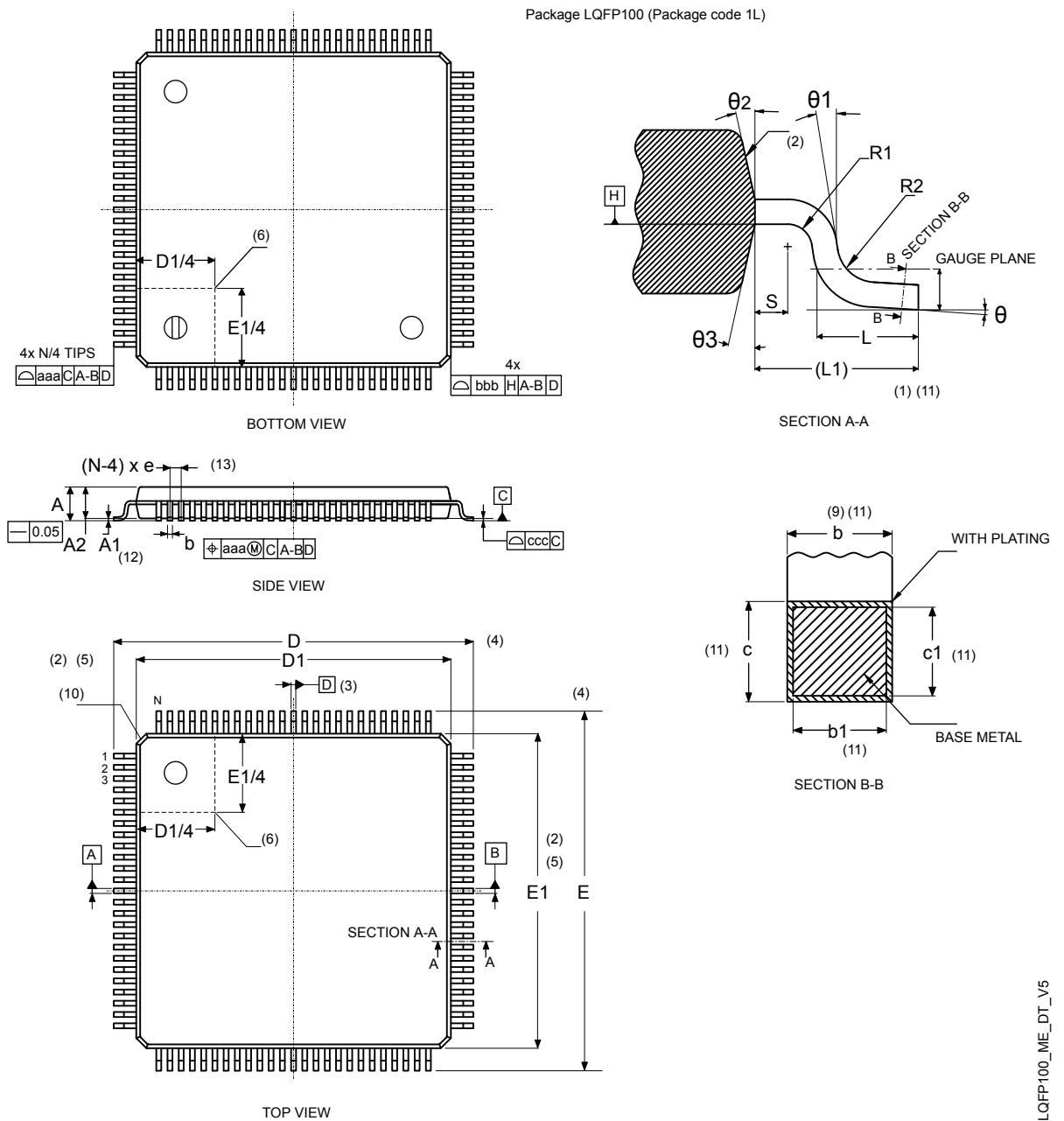

1L_LQFP100_ME_DT_V5

Table 85. LQFP100 - Mechanical data

Symbol	millimeters			inches ^(14.)		
	Min	Typ	Max	Min	Typ	Max
A	-	1.50	1.60	-	0.0590	0.0630
A1 ^(12.)	0.05	-	0.15	0.0020	-	0.0059
A2	1.35	1.40	1.45	0.0531	0.0551	0.0571
b ^(9.) (11.)	0.17	0.22	0.27	0.0067	0.0087	0.0106
b1 ^(11.)	0.17	0.20	0.23	0.0067	0.0079	0.0090
c ^(11.)	0.09	-	0.20	0.0035	-	0.0079
c1 ^(11.)	0.09	-	0.16	0.0035	-	0.0063
D ^(4.)	16.00 BSC			0.6299 BSC		
D1 ^(2.) (5.)	14.00 BSC			0.5512 BSC		
E ^(4.)	16.00 BSC			0.6299 BSC		
E1 ^(2.) (5.)	14.00 BSC			0.5512 BSC		
e	0.50 BSC			0.0197 BSC		
L	0.45	0.60	0.75	0.0177	0.0236	0.0295
L1 ^(1.) (11.)	-	1.00	-	-	0.0394	-
N ^(13.)	100					
Θ	0°	3.5°	7°	0°	3.5°	7°
Θ1	0°	-	-	0°	-	-
Θ2	10°	12°	14°	10°	12°	14°
Θ3	10°	12°	14°	10°	12°	14°
R1	0.08	-	-	0.0031	-	-
R2	0.08	-	0.20	0.0031	-	0.0079
S	0.20	-	-	0.0079	-	-
aaa ^(1.)	0.20			0.0079		
bbb ^(1.)	0.20			0.0079		
ccc ^(1.)	0.08			0.0031		
ddd ^(1.)	0.08			0.0031		

Notes

1. Dimensioning and tolerancing schemes conform to ASME Y14.5M-1994.
2. The top package body size may be smaller than the bottom package size by as much as 0.15 mm.
3. Datums A-B and D to be determined at datum plane H.
4. To be determined at seating datum plane C.
5. Dimensions D1 and E1 do not include mold flash or protrusions. Allowable mold flash or protrusions is "0.25 mm" per side. D1 and E1 are maximum plastic body size dimensions including mold mismatch.
6. Details of pin 1 identifier are optional but must be located within the zone indicated.
7. All dimensions are in millimeters.
8. No intrusion is allowed inwards the leads.
9. Dimension "b" does not include a dambar protrusion. Allowable dambar protrusion shall not cause the lead width to exceed the maximum "b" dimension by more than 0.08 mm. Dambar cannot be located on the lower radius or the foot. The minimum space between the protrusion and an adjacent lead is 0.07 mm for 0.4 mm and 0.5 mm pitch packages.
10. The exact shape of each corner is optional.
11. These dimensions apply to the flat section of the lead between 0.10 mm and 0.25 mm from the lead tip.
12. A1 is defined as the distance from the seating plane to the lowest point on the package body.
13. "N" is the number of terminal positions for the specified body size.
14. Values in inches are converted from mm and rounded to 4 decimal digits.
15. Drawing is not to scale.

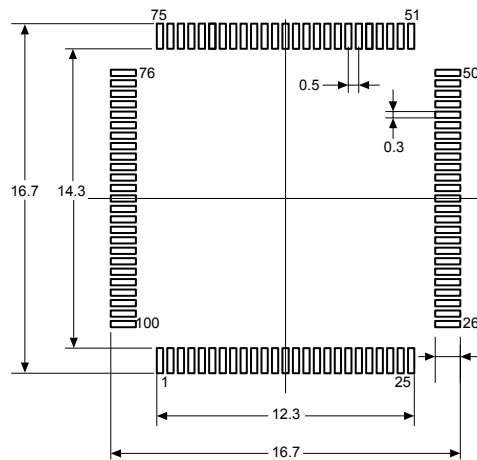
Figure 57. LQFP100 - Footprint example

1L_LQFP100_FP_DT_V1

1. Dimensions are expressed in millimeters.

6.9 Package thermal characteristics

The maximum chip-junction temperature, $T_J \text{ max}$, in degrees Celsius, can be calculated using the following equation:

$$T_J \text{ max} = T_A \text{ max} + (P_D \text{ max} \times \theta_{JA})$$

Where:

- $T_A \text{ max}$ is the maximum ambient temperature in °C.
- θ_{JA} is the package junction-to-ambient thermal resistance in °C/W.
- $P_D \text{ max}$ is the sum of $P_{INT} \text{ max}$ and $P_{I/O} \text{ max}$:

$$P_D \text{ max} = P_{INT} \text{ max} + P_{I/O} \text{ max}$$

- $P_{INT} \text{ max}$ is the product of I_{DD} and V_{DD} , expressed in Watts. This is the maximum chip internal power.
- $P_{I/O} \text{ max}$ represents the maximum power dissipation on output pins:

$$P_{I/O} \text{ max} = \sum (V_{OL} \times I_{OL}) + \sum ((V_{DDIOx} - V_{OH}) \times I_{OH})$$

taking into account the actual V_{OL}/I_{OL} and V_{OH}/I_{OH} of the I/Os at low and high level in the application.

Table 86. Package thermal characteristics

Symbol	Definition	Parameter	Value			Unit
			junction-ambient θ_{JA}	junction-board θ_{JB}	junction-case θ_{JC}	
θ	Thermal resistance	LQFP144	39.0	27.8	10.3	°C/W
		LQFP100	38.0	24.0	10.4	
		LQFP80	41.0	25.3	11.7	
		LQFP64	42.6	24.9	12.1	
		LQFP48	49.6	26.9	14.6	
		LQFP32	49.6	26.9	14.6	
		UFQFPN48	30.1	14.4	9.7	
		UFQFPN32	38.2	19.9	19.5	

6.9.1 Reference documents

- JESD51-2 Integrated Circuits Thermal Test Method Environment Conditions - Natural Convection (Still Air) available on www.jedec.org.
- For information on thermal management, refer to application note "Guidelines for thermal management on STM32 applications" (AN5036) available on www.st.com.

7 Ordering information

Example:	STM32	C	5A3	K	E	T	6	TR
Device family	STM32 = Arm-based 32-bit microcontroller							
Product type	C = General purpose							
Device subfamily	5A3 = Product with FDCAN and Ethernet							
Pin count	K = 32 pins C = 48 pins R = 64 pins M = 80 pins V = 100 pins Z = 144 pins							
Flash memory size	G = 1024 Kbytes							
Package	U = UFQFPN T = LQFP							
Temperature range	6 = Temperature range, -40 to +85°C (+105°C junction) 3 = Temperature range, -40 to +125°C (+140°C junction)							
Packing	TR = tape and reel xxx = programmed parts							

Note: For a list of available options (such as speed and package) or for further information on any aspect of this device, contact your nearest ST sales office.

Important security notice

The STMicroelectronics group of companies (ST) places a high value on product security, which is why the ST product(s) identified in this documentation may be certified by various security certification bodies and/or may implement our own security measures as set forth herein. However, no level of security certification and/or built-in security measures can guarantee that ST products are resistant to all forms of attacks. As such, it is the responsibility of each of ST's customers to determine if the level of security provided in an ST product meets the customer needs both in relation to the ST product alone, as well as when combined with other components and/or software for the customer end product or application. In particular, take note that:

- ST products may have been certified by one or more security certification bodies, such as Platform Security Architecture (www.psacertified.org) and/or Security Evaluation standard for IoT Platforms (www.trustcb.com). For details concerning whether the ST product(s) referenced herein have received security certification along with the level and current status of such certification, either visit the relevant certification standards website or go to the relevant product page on www.st.com for the most up to date information. As the status and/or level of security certification for an ST product can change from time to time, customers should re-check security certification status/level as needed. If an ST product is not shown to be certified under a particular security standard, customers should not assume it is certified.
- Certification bodies have the right to evaluate, grant and revoke security certification in relation to ST products. These certification bodies are therefore independently responsible for granting or revoking security certification for an ST product, and ST does not take any responsibility for mistakes, evaluations, assessments, testing, or other activity carried out by the certification body with respect to any ST product.
- Industry-based cryptographic algorithms (such as AES, DES, or MD5) and other open standard technologies which may be used in conjunction with an ST product are based on standards which were not developed by ST. ST does not take responsibility for any flaws in such cryptographic algorithms or open technologies or for any methods which have been or may be developed to bypass, decrypt or crack such algorithms or technologies.
- While robust security testing may be done, no level of certification can absolutely guarantee protections against all attacks, including, for example, against advanced attacks which have not been tested for, against new or unidentified forms of attack, or against any form of attack when using an ST product outside of its specification or intended use, or in conjunction with other components or software which are used by customer to create their end product or application. ST is not responsible for resistance against such attacks. As such, regardless of the incorporated security features and/or any information or support that may be provided by ST, each customer is solely responsible for determining if the level of attacks tested for meets their needs, both in relation to the ST product alone and when incorporated into a customer end product or application.
- All security features of ST products (inclusive of any hardware, software, documentation, and the like), including but not limited to any enhanced security features added by ST, are provided on an "AS IS" BASIS. AS SUCH, TO THE EXTENT PERMITTED BY APPLICABLE LAW, ST DISCLAIMS ALL WARRANTIES, EXPRESS OR IMPLIED, INCLUDING BUT NOT LIMITED TO THE IMPLIED WARRANTIES OF MERCHANTABILITY OR FITNESS FOR A PARTICULAR PURPOSE, unless the applicable written and signed contract terms specifically provide otherwise.

Revision history

Table 87. Document revision history

Date	Revision	Changes
27-Feb-2026	1	Initial release.

Contents

1	Introduction	3
2	Description	4
3	Functional overview	7
3.1	Arm® Cortex®-M33 with FPU	7
3.2	Instruction cache (ICACHE)	8
3.3	Memory protection unit	8
3.4	Memories	8
3.4.1	Embedded flash memory	8
3.4.2	Embedded SRAMs	9
3.5	Boot modes	9
3.6	Power supply management	9
3.6.1	Power supply schemes	10
3.6.2	Power supply supervisor	11
3.6.3	Low-power modes	11
3.6.4	Reset mode	11
3.7	Peripheral interconnect matrix	11
3.8	Reset and clock controller (RCC)	12
3.9	Clock recovery system (CRS)	12
3.10	General-purpose inputs/outputs (GPIOs)	12
3.11	Multi-AHB bus matrix	12
3.12	Low-power direct memory access controller (LPDMA)	13
3.13	Interrupts and events	14
3.13.1	Nested vectored interrupt controller (NVIC)	14
3.13.2	Extended interrupt and event controller (EXTI)	14
3.14	Cyclic redundancy check calculation unit (CRC)	15
3.15	Extended-SPI interface (XSPI)	15
3.16	Delay block (DLYB)	16
3.17	Analog-to-digital converter (ADC)	16
3.17.1	Analog temperature sensor	18
3.17.2	Internal voltage reference (V_{REFINT})	18
3.18	Digital to analog converter (DAC)	18
3.19	Ultralow-power comparator (COMP)	19
3.20	Coupling and chaining bridge (CCB)	19
3.21	True random number generator (RNG)	20

3.22	AES hardware accelerator (AES)	20
3.23	Secure AES coprocessor (SAES)	21
3.24	HASH processor (HASH)	22
3.25	Public key accelerator (PKA)	23
3.26	Timers and watchdogs	24
3.26.1	Advanced-control timers (TIM1/TIM8)	24
3.26.2	General-purpose timers (TIM2/TIM3/TIM4/TIM5/TIM12/TIM15/TIM16/TIM17)	25
3.26.3	Basic timers (TIM6/TIM7)	26
3.26.4	Low-power timers (LPTIM1)	26
3.26.5	Independent watchdog (IWDG)	26
3.26.6	Window watchdog (WWDG)	27
3.26.7	SysTick timer	27
3.27	Real-time clock (RTC), tamper and backup registers	28
3.27.1	Real-time clock (RTC)	28
3.27.2	Tamper and backup registers (TAMP)	28
3.28	Inter-integrated circuit interface (I2C)	28
3.29	Improved inter-integrated circuit interface (I3C)	29
3.30	Universal synchronous/asynchronous receiver transmitter (USART/UART) and low-power universal asynchronous receiver transmitter (LPUART)	32
3.30.1	Universal synchronous/asynchronous receiver transmitter (USART/UART)	32
3.30.2	Low-power universal asynchronous receiver transmitter (LPUART)	33
3.31	Serial peripheral interface (SPI)/Inter-integrated sound interfaces (I2S)	34
3.32	Controller area network (FDCAN)	36
3.33	Universal serial bus full-speed host/device interface (USB)	36
3.34	Ethernet (ETH): media access control (MAC) with DMA controller	37
3.35	Development support	39
3.35.1	Serial-wire/JTAG debug port (SWJ-DP)	39
3.35.2	Embedded Trace Macrocell™	39
4	Pinouts/ballouts, pin description, and alternate functions	40
4.1	Pinout/ballout schematics	40
4.2	Pin description	45
4.3	Alternate functions	59
5	Electrical characteristics	63
5.1	Parameter conditions	63
5.1.1	Minimum and maximum values	63
5.1.2	Typical values	63
5.1.3	Typical curves	63

5.1.4	Loading capacitor	63
5.1.5	Pin input voltage	63
5.1.6	Power supply scheme	64
5.2	Absolute maximum ratings	65
5.3	Operating conditions	66
5.3.1	General operating conditions	66
5.3.2	Operating conditions at power-up/power-down	67
5.3.3	Embedded reset and power control block characteristics	67
5.3.4	Inrush current and inrush electric charge characteristics	67
5.3.5	Embedded voltage reference	68
5.3.6	Supply current characteristics	68
5.3.7	Wake-up time from low-power modes and voltage scaling transition times	73
5.3.8	External clock timing characteristics	73
5.3.9	Internal clock timing characteristics	78
5.3.10	Flash memory characteristics	82
5.3.11	EMC characteristics	83
5.3.12	Electrical sensitivity characteristics	84
5.3.13	I/O current injection characteristics	85
5.3.14	I/O port characteristics	86
5.3.15	NRST pin characteristics	90
5.3.16	Extended interrupt and event controller input (EXTI) characteristics	91
5.3.17	XSPI interface characteristics	91
5.3.18	Delay block (DLYB) characteristics	95
5.3.19	12-bit analog-to-digital converter ADC characteristics	95
5.3.20	Temperature sensor characteristics	100
5.3.21	Digital-to-analog converter characteristics (DAC)	100
5.3.22	Comparator characteristics	103
5.3.23	Timer characteristics	104
5.3.24	I3C interface characteristics	105
5.3.25	I ² C interface characteristics	105
5.3.26	USART characteristics	106
5.3.27	SPI characteristics	107
5.3.28	USB_FS characteristics	110
5.3.29	Ethernet interface characteristics	110
5.3.30	JTAG/SWD interface characteristics	112
6	Package information	114
6.1	Device marking	114
6.2	LQFP32 package information (5V)	115

6.3	UFQFPN32 package information (A0B8)	118
6.4	LQFP48 package information (5B)	121
6.5	UFQFPN48 package information (A0B9)	124
6.6	LQFP64 package information (5W)	126
6.7	LQFP80 package information (9X)	129
6.8	LQFP100 package information (1L)	132
6.9	Package thermal characteristics	135
6.9.1	Reference documents	135
7	Ordering information	136
	Important security notice	137
	Revision history	138
	List of tables	143
	List of figures	145

List of tables

Table 1.	Device features and peripheral counts	4
Table 2.	LPDMA1 and LPDMA2 channels implementation and usage	13
Table 3.	LPDMA1 and LPDMA2 autonomous mode and wake-up in low-power modes	14
Table 4.	ADC features	18
Table 5.	AES features	21
Table 6.	AES versus SAES features	22
Table 7.	Timer feature comparison	24
Table 8.	I2C implementation	29
Table 9.	I3C peripheral controller/target features versus MIPI® v1.1	31
Table 10.	USART, UART, and LPUART features	32
Table 11.	SPI features	34
Table 12.	Legend/abbreviations used in the pinout table	45
Table 13.	STM32C5A3xxx pin/ball definition	46
Table 14.	Alternate functions	59
Table 15.	Voltage characteristics	65
Table 16.	Current characteristics	65
Table 17.	Thermal characteristics	66
Table 18.	General operating conditions	66
Table 19.	Operating conditions at power-up/power-down	67
Table 20.	Embedded reset and power control block characteristics	67
Table 21.	Embedded internal voltage reference	67
Table 22.	Embedded internal voltage reference	68
Table 23.	Internal reference voltage calibration values	68
Table 24.	Typical and maximum current consumption in Run mode	69
Table 25.	Typical current consumption in Run mode with CoreMark running from flash memory and SRAM	69
Table 26.	Typical and maximum current consumption in Sleep mode	70
Table 27.	Typical and maximum current consumption in Stop mode	70
Table 28.	Typical and maximum HSIKERON current consumption in Stop mode	70
Table 29.	Typical and maximum current consumption in Standby mode	70
Table 30.	Peripheral current consumption measured in Sleep mode	71
Table 31.	Wake-up time from low-power modes	73
Table 32.	Wake-up time using USART/LPUART	73
Table 33.	High-speed external user clock characteristics	73
Table 34.	Low-speed external user clock characteristics	75
Table 35.	4-50 MHz HSE oscillator characteristics	76
Table 36.	LSE oscillator characteristics ($f_{LSE} = 32.768$ kHz)	77
Table 37.	HSI144 oscillator characteristics	78
Table 38.	PSI oscillator characteristics	80
Table 39.	LSI oscillator characteristics	82
Table 40.	Flash memory characteristics	82
Table 41.	Flash memory programming	82
Table 42.	Flash memory user and EDATA endurance and data retention	82
Table 43.	EMS characteristics	83
Table 44.	EMI characteristics for $f_{HSE} = 16$ MHz and $f_{HCLK} = 144$ MHz	84
Table 45.	ESD absolute maximum ratings	84
Table 46.	Electrical sensitivities	84
Table 47.	I/O current injection susceptibility	85
Table 48.	I/O static characteristics	86
Table 49.	Output voltage characteristics (all I/Os except PC14 and PC15)	88
Table 50.	Output voltage characteristics for PC14 and PC15	88
Table 51.	Output AC characteristics (all I/Os except PC13)	89
Table 52.	NRST pin characteristics	90

Table 53.	EXTI input characteristics	91
Table 54.	XSPI characteristics in SRD mode	91
Table 55.	XSPI characteristics in DTR mode (no DQS)	91
Table 56.	XSPI characteristics in DTR mode (with DQS) / HyperBus	92
Table 57.	DLYB characteristics	95
Table 58.	12-bit ADC characteristics	95
Table 59.	12-bit ADC accuracy	96
Table 60.	Temperature sensor characteristics	100
Table 61.	Temperature sensor calibration values	100
Table 62.	DAC characteristics	100
Table 63.	DAC accuracy	103
Table 64.	COMP characteristics	103
Table 65.	TIMx characteristics	104
Table 66.	IWDG min/max timeout period at 32 kHz (LSI)	105
Table 67.	Open drain timing measurements	105
Table 68.	I ² C analog filter characteristics	106
Table 69.	USART characteristics	106
Table 70.	SPI characteristics	107
Table 71.	USB_FS characteristics	110
Table 72.	Dynamic characteristics: Ethernet MAC signals for SMI	110
Table 73.	Dynamic characteristics: Ethernet MAC signals for RMII	110
Table 74.	Dynamic characteristics: Ethernet MAC signals for MII	110
Table 75.	JTAG characteristics	112
Table 76.	SWD characteristics	113
Table 77.	LQFP32 - Mechanical data	116
Table 78.	UFQFPN32 - Mechanical data	119
Table 79.	Tolerance of form and position	119
Table 80.	Tolerance of form and position symbol definition	120
Table 81.	LQFP48 - Mechanical data	122
Table 82.	UFQFPN48 - Mechanical data	125
Table 83.	LQFP64 - Mechanical data	127
Table 84.	LQFP80 - Mechanical data	130
Table 85.	LQFP100 - Mechanical data	133
Table 86.	Package thermal characteristics	135
Table 87.	Document revision history	138

List of figures

Figure 1.	STM32C5A3xxx block diagram	6
Figure 2.	STM32C5A3xxx power supply overview.	10
Figure 3.	LQFP32 pinout	40
Figure 4.	UFQFPN32 pinout	40
Figure 5.	LQFP48 pinout	41
Figure 6.	UFQFPN48 pinout	41
Figure 7.	LQFP64 pinout	42
Figure 8.	LQFP80 pinout	42
Figure 9.	LQFP100 pinout	43
Figure 10.	LQFP144 pinout	44
Figure 11.	Pin loading conditions	63
Figure 12.	Pin input voltage	63
Figure 13.	STM32C5A3xxx power supply scheme	64
Figure 14.	AC timing diagram for high-speed external clock source (digital mode)	74
Figure 15.	AC timing diagram for high-speed external clock source (analog mode)	74
Figure 16.	Low-speed external clock source AC timing diagram	75
Figure 17.	Typical application with a 8 MHz crystal	76
Figure 18.	Typical application with a 32.768 kHz crystal	77
Figure 19.	HSI frequency versus temperature	79
Figure 20.	I/O input characteristics (all I/Os)	87
Figure 21.	Output AC characteristics definition	90
Figure 22.	Recommended NRST pin protection	90
Figure 23.	OCTOSPI SDR read/write timing diagram	93
Figure 24.	OCTOSPI timing diagram - DTR mode	93
Figure 25.	OCTOSPI Hyperbus clock	93
Figure 26.	OCTOSPI Hyperbus read.	94
Figure 27.	OCTOSPI Hyperbus write	94
Figure 28.	Minimum sampling time versus RAIN for 12 bits resolution	97
Figure 29.	Minimum sampling time versus RAIN for 10 bits resolution	97
Figure 30.	Minimum sampling time versus RAIN for 8 bits resolution.	98
Figure 31.	Minimum sampling time versus RAIN for 6 bits resolution.	98
Figure 32.	ADC accuracy characteristics	99
Figure 33.	Typical connection diagram when using the ADC with FT/TT pins featuring analog switch function	99
Figure 34.	12-bit buffered/non-buffered DAC	102
Figure 35.	USART timing diagram in SPI master mode	107
Figure 36.	USART timing diagram in SPI slave mode	107
Figure 37.	SPI timing diagram - slave mode and CPHA = 0	108
Figure 38.	SPI timing diagram - slave mode and CPHA = 1	109
Figure 39.	SPI timing diagram - master mode	109
Figure 40.	RMII timing diagram	111
Figure 41.	MII timing diagram	111
Figure 42.	SMI timing diagram	112
Figure 43.	JTAG timing diagram	113
Figure 44.	SWD timing diagram	113
Figure 45.	LQFP32- Outline.	115
Figure 46.	LQFP32 - Footprint example	117
Figure 47.	UFQFPN32 - Outline	118
Figure 48.	UFQFPN32 - Footprint example	120
Figure 49.	LQFP48- Outline ^(15.)	121
Figure 50.	LQFP48 - Footprint example	123
Figure 51.	UFQFPN48 - Outline	124
Figure 52.	UFQFPN48 - Footprint example	125
Figure 53.	LQFP64 - Outline ^(15.)	126

Figure 54.	LQFP80 - Outline ^(15.)	129
Figure 55.	LQFP80 - Footprint example	131
Figure 56.	LQFP100 - Outline ^(15.)	132
Figure 57.	LQFP100 - Footprint example.	134

IMPORTANT NOTICE – READ CAREFULLY

STMicroelectronics NV and its subsidiaries (“ST”) reserve the right to make changes, corrections, enhancements, modifications, and improvements to ST products and/or to this document at any time without notice.

In the event of any conflict between the provisions of this document and the provisions of any contractual arrangement in force between the purchasers and ST, the provisions of such contractual arrangement shall prevail.

The purchasers should obtain the latest relevant information on ST products before placing orders. ST products are sold pursuant to ST’s terms and conditions of sale in place at the time of order acknowledgment.

The purchasers are solely responsible for the choice, selection, and use of ST products and ST assumes no liability for application assistance or the design of the purchasers’ products.

No license, express or implied, to any intellectual property right is granted by ST herein.

Resale of ST products with provisions different from the information set forth herein shall void any warranty granted by ST for such product.

If the purchasers identify an ST product that meets their functional and performance requirements but that is not designated for the purchasers’ market segment, the purchasers shall contact ST for more information.

ST and the ST logo are trademarks of ST. For additional information about ST trademarks, refer to www.st.com/trademarks. All other product or service names are the property of their respective owners.

Information in this document supersedes and replaces information previously supplied in any prior versions of this document.

© 2026 STMicroelectronics – All rights reserved