

4-520447-2 ✓ ACTIVE

Ultra-Fast | Ultra-Fast 250

TE Internal #: 4-520447-2

Quick Disconnects, Receptacle, 12 – 10 AWG Wire Size, 3.31 – 5.26 mm² Wire Size, Mating Tab Width .25 in [6.35 mm], Straight, Brass, Ultra-Fast 250

[View on TE.com >](#)



Terminals & Splices > Quick Disconnects

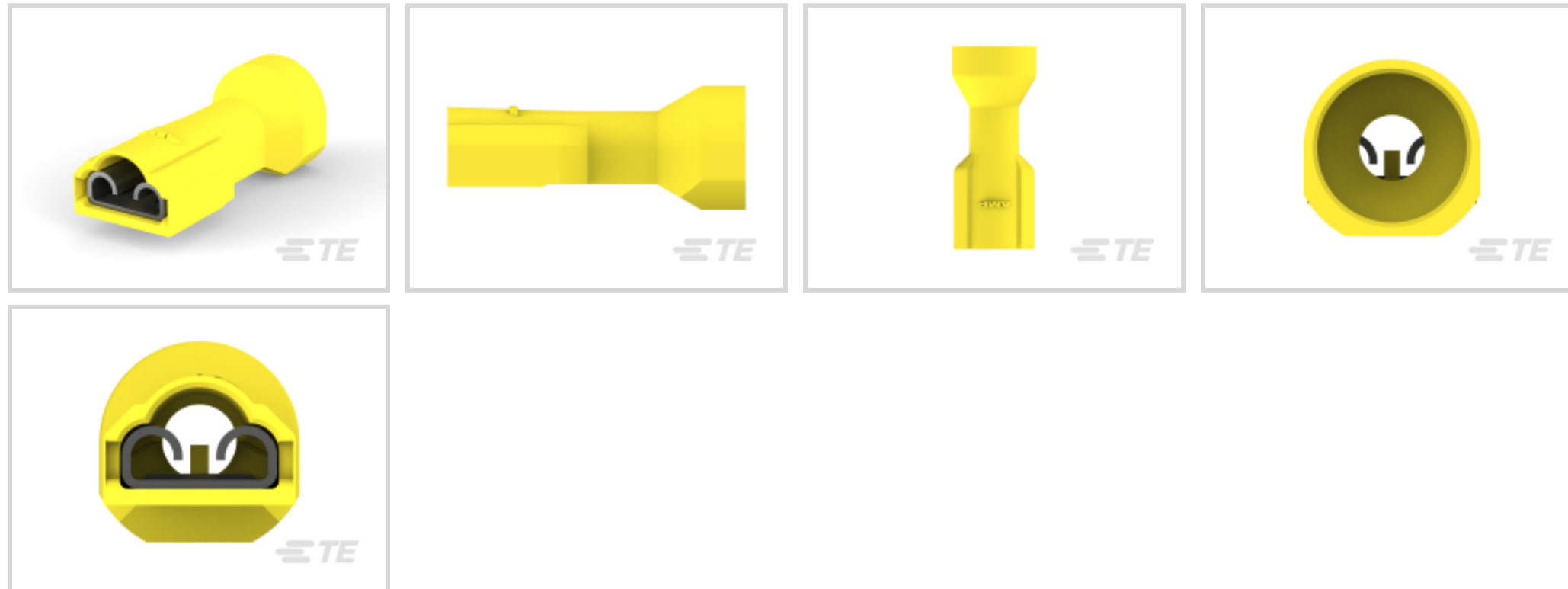

Quick Disconnect Terminal Type: **Receptacle**

Wire Size: **3.31 – 5.26 mm²**

Mating Tab Width: **6.35 mm [.25 in]**

Mating Tab Thickness: **.81 mm [.032 in]**

Features

Product Type Features

Terminates To	Wire & Cable
Wire/Cable Type	Discrete Wire
Wire Stop	Yes
Insertion Force	Normal
Sealable	No

Configuration Features

Connection Capacity	Single
---------------------	--------

Electrical Characteristics

Voltage (Max)	600 V
---------------	-------

Body Features

Insulation Material	Nylon
---------------------	-------

Contact Features

Quick Disconnect Terminal Type	Receptacle
Mating Tab Width	6.35 mm [.25 in]



Mating Tab Thickness	.81 mm[.032 in]
Terminal Orientation	Straight
Contact Base Material	Brass
Terminal Plating Material	Tin
Crimp Type	F-Crimp
Barrel Type	Closed

Mechanical Attachment

Mating Retention Type	Dimple
Wire Insulation Support	With

Dimensions

Accepts Wire Insulation Diameter Range	8.13 mm[.32 in]
Receptacle Terminal Stock Thickness	.41 mm[.016 in]
Overall Length	23.7 mm[.935 in]
Wire Size	3.31 – 5.26 mm ²

Usage Conditions

Insulation Option	Fully Insulated
Operating Temperature Range	-40 – 110 °C[-40 – 230 °F]

Industry Standards

UL Flammability Rating	UL 94V-2
UL Rating	Listed

Packaging Features

Packaging Quantity	1500
Packaging Method	Strip/Reel

Other

Barrel Color	Yellow
--------------	--------

Product Compliance

[For compliance documentation, visit the product page on TE.com>](#)

EU RoHS Directive 2011/65/EU	Compliant
EU ELV Directive 2000/53/EC	Compliant
China RoHS 2 Directive MIIT Order No 32, 2016	No Restricted Materials Above Threshold
EU REACH Regulation (EC) No. 1907/2006	



Current ECHA Candidate List: JAN 2023
(233)
Candidate List Declared Against: JAN 2023
(233)
Does not contain REACH SVHC

Halogen Content
Low Halogen - Br, Cl, F, I < 900 ppm per homogenous material. Also BFR/CFR/PVC Free

Solder Process Capability
Not applicable for solder process capability

Product Compliance Disclaimer

This information is provided based on reasonable inquiry of our suppliers and represents our current actual knowledge based on the information they provided. This information is subject to change. The part numbers that TE has identified as EU RoHS compliant have a maximum concentration of 0.1% by weight in homogenous materials for lead, hexavalent chromium, mercury, PBB, PBDE, DBP, BBP, DEHP, DIBP, and 0.01% for cadmium, or qualify for an exemption to these limits as defined in the Annexes of Directive 2011/65/EU (RoHS2). Finished electrical and electronic equipment products will be CE marked as required by Directive 2011/65/EU. Components may not be CE marked. Additionally, the part numbers that TE has identified as EU ELV compliant have a maximum concentration of 0.1% by weight in homogenous materials for lead, hexavalent chromium, and mercury, and 0.01% for cadmium, or qualify for an exemption to these limits as defined in the Annexes of Directive 2000/53/EC (ELV). Regarding the REACH Regulation, the information TE provides on SVHC in articles for this part number is based on the latest European Chemicals Agency (ECHA) 'Guidance on requirements for substances in articles' posted at this URL: <https://echa.europa.eu/guidance-documents/guidance-on-reach>

Compatible Parts

TE Part # 58630-2
PROCAMP DIESET 12-10 ULTRAFast

TE Part # 2-2151029-2
OCEAN_2.0_APPLICATOR-S-278D

TE Part # 2151029-2
OCEAN_2.0_APPLICATOR-S-278D

TE Part # 224027-1
DIES FASTON REC 10AWG DIE SET

TE Part # 224027-2
DIES FASTON REC 12AWG DIE SET

Also in the Series | **Ultra-Fast 250**



Automotive Housings(1)



Quick Disconnects(48)

Customers Also Bought

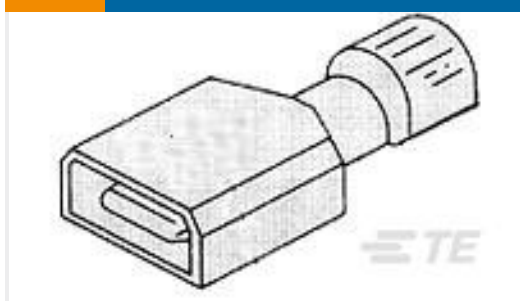

TE Part #4-521097-2
ULTRA-FAST 250 ASY TAB 12-10 AWG TPBR

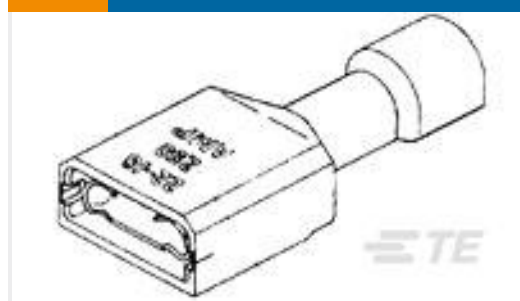

TE Part #3-350815-2
ULTRA-FAST 187 ASY REC 16-14 AWG TPBR

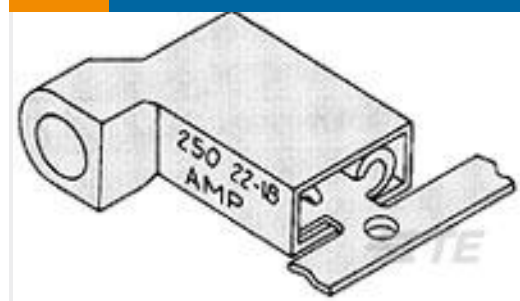

TE Part #3-520132-2
ULTRAFast 250 ASSY FLAG REC 16-14 TPBR



TE Part #2-520128-2
ULTRA-FAST 250 ASY REC 22-18 AWG TPBR



TE Part #1604001-2
120A SGL POLE HSG SUBASY, BLACK

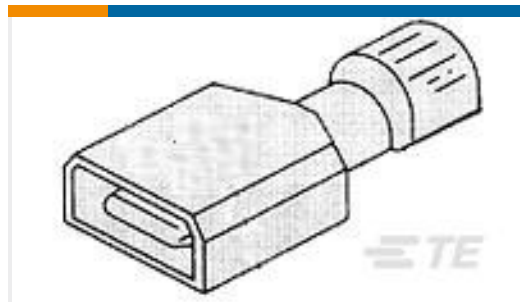

TE Part #3-520106-2
ULTRA-FAST 250 ASY TAB 16-14 AWG TPBR

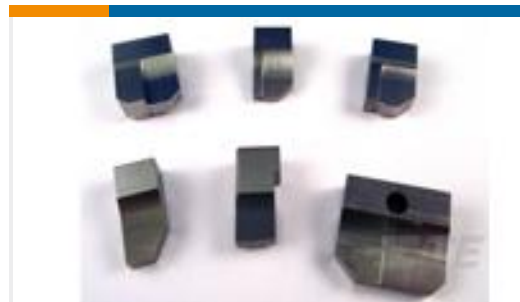

TE Part #464291-5
ANVIL, SAND-BLASTED 12-10

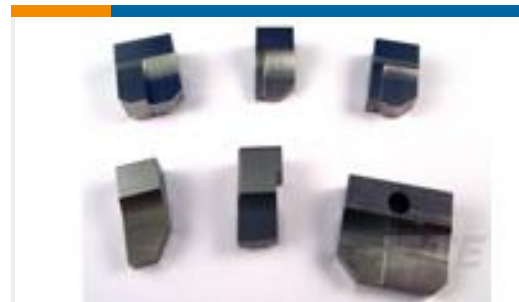

TE Part #467341-2
ANVIL, RIGHT HAND (16-14)

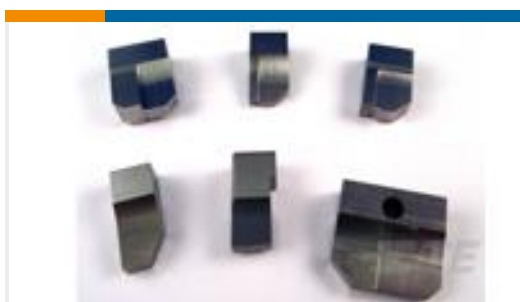

TE Part #662183-4
ANVIL, COMBINATION .055



TE Part #811239-1
SHEAR PLATE

Documents

Product Drawings

[ULTRA-FAST 250 ASY REC 12-10 AWG TPBR](#)

English

CAD Files

[3D PDF](#)

[3D](#)

[Customer View Model](#)

[ENG_CVM_CVM_4-520447-2_K.2d_dxf.zip](#)



English

Customer View Model

[ENG_CVM_CVM_4-520447-2_K.3d_igs.zip](#)

English

Customer View Model

[ENG_CVM_CVM_4-520447-2_K.3d_stp.zip](#)

English

By downloading the CAD file I accept and agree to the [Terms and Conditions](#) of use.

Datasheets & Catalog Pages

[Ultra-Fast and Ultra Fast Plus](#)

English

Product Specifications

[Application Specification](#)

English

[Application Specification](#)

English

Product Environmental Compliance

[MD_4-520447-2_092520181020_dmtec](#)

English

[MD_4-520447-2_092520181020_dmtec](#)

English

Agency Approvals

[UL](#)

English