

SmartIndustrial™ 6-axis MotionTracking® MEMS Device for Industrial Applications

GENERAL DESCRIPTION

The IIM-20670 is a SmartIndustrial™ 6-axis MotionTracking device that combines a 3-axis gyroscope and a 3-axis accelerometer in a small plastic package. By leveraging its patented and volume-proven CMOS-MEMS fabrication platform, InvenSense has driven the package size down to a footprint and thickness of 4.5x4.5x1.1 mm³ (24-pin DQFN), to offer fully integrated, high performance component in a compact form factor.

The IIM-20670 features:

- Six independent mechanical structures
- Gyroscope with programmable full scale range from ±41 dps to ±1966 dps
- Accelerometer with programmable full-scale range from ±2g, to ±65g
- Two temperature sensors
- 10 MHz Serial Peripheral Interface (SPI)
- 10,000 g shock tolerant structure
- Low offset and sensitivity variation over temperature

IIM-20670 includes on-chip 16-bit ADCs, programmable digital filters, and an embedded temperature sensor. The device features an operating voltage range from 5.5V down to 3.0V, and a current consumption below 10 mA in all the operating conditions.

ORDERING INFORMATION

PART NUMBER	TEMPERATURE	PACKAGE
IIM-20670†	-40°C to +105°C	24-Pin DQFN

†Denotes RoHS and Green-compliant package

APPLICATIONS

IIM-20670 addresses a wide range of Industrial applications, including but not limited to

- Navigation
- Platform stabilization
- Asset Tracking
- Robotics
- Industrial automation
- Smart transportation
- Agriculture and construction machinery

TYPICAL OPERATING CIRCUIT

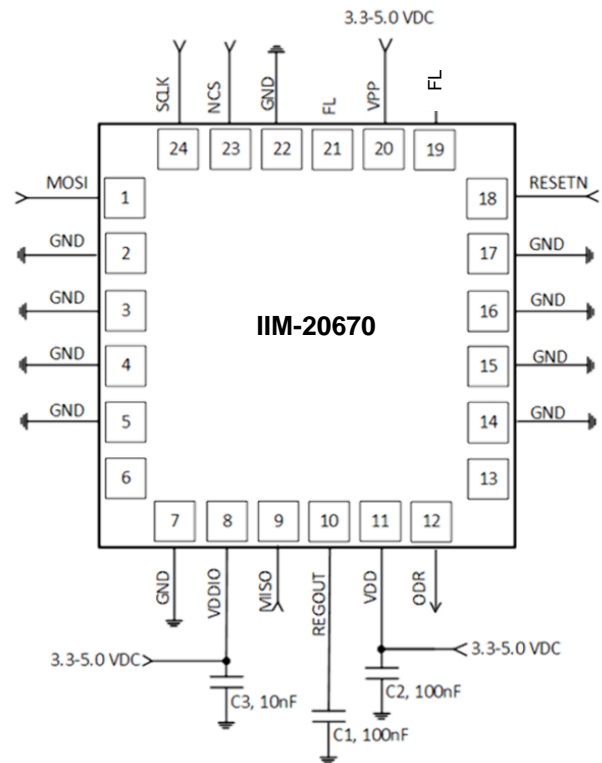

TABLE OF CONTENTS

General Description 1

Ordering Information..... 1

Applications 1

Typical Operating Circuit 1

1 Introduction 6

 1.1 Purpose and Scope..... 6

 1.2 Product Overview 6

 1.3 Applications 6

 1.4 Features 6

2 Features 7

 2.1 Gyroscope Features 7

 2.2 Accelerometer Features..... 7

 2.3 Additional Features 7

3 Target Electrical Characteristics..... 8

 3.1 Gyroscope Specifications 8

 3.2 Accelerometer Specifications 9

 3.3 Temperature Sensor Specifications 10

 3.4 Electrical Specifications..... 10

 3.5 SPI Timing Characterization 11

 3.6 Absolute Maximum Ratings 12

 3.7 Thermal Info..... 12

4 Applications Information 13

 4.1 Pinout Diagram and Signal Description..... 13

 4.2 Typical Operating Circuit..... 14

 4.3 Bill of Materials for External Components 14

 4.4 Block Diagram 15

 4.5 Overview 15

 4.6 Signal Conditioning And Filtering 15

 4.7 Three-Axis MEMS Gyroscope with 16-bit ADCs and Signal Conditioning 16

 4.8 Three-Axis MEMS Accelerometer with 16-bit ADCs and Signal Conditioning 16

 4.9 Temperature Sensors..... 17

 4.10 Serial Communications Interface 17

 4.11 SPI Readings Synchronous with Internal ODR..... 17

 4.12 Self-test 18

 4.13 Clocking 18

 4.14 Sensor Data Registers 18

4.15	Bias, Regulators, references, Charge Pumps, and Supplies	18
4.16	Internal Buses	19
5	Digital Interface	20
5.1	Serial Interface Pin Descriptions	20
5.2	Protocol.....	21
5.3	SPI commands for Accelerometer self-test.....	22
5.4	SPI commands for Gyroscope self-test	23
6	Register Descriptions	24
6.1	Gyroscope Data.....	24
6.2	Temperature 1 Data.....	24
6.3	Accelerometer Data	24
6.4	Temperature 2 Data.....	24
6.5	Low Resolution Accelerometer Data	24
6.6	Fixed Value.....	25
6.7	Accelerometer And Gyroscope Y and Z Filter Settings	25
6.8	Accelerometer And Gyroscope X-Axis Filter Settings	27
6.9	Temperature Sensors Difference	28
6.10	Self-test Register	29
6.11	Test Register	29
6.12	Reset Control	29
6.13	Mode Registers	30
6.14	ID Registers	30
6.15	ODR Configuration	30
6.16	Bank Selection.....	31
6.17	Sensitivity Configuration	31
7	Assembly.....	33
7.1	Orientation of Axes	33
7.2	Package Dimensions	33
8	Part Number Package Marking.....	36
9	Reference.....	37
10	Document Information	38
10.1	Revision History	38

LIST OF FIGURES

Figure 1. SPI bus timing diagram11
Figure 2. Thermal parameters characterization points12
Figure 3. Top View – DQFN package 24-pin 4.5 mm x 4.5 mm x 1.1 mm13
Figure 4. Application Schematic.....14
Figure 5. IIM-20670 Block Diagram.....15
Figure 6: SPI synchronization with ODR.....17
Figure 7. Typical SPI Master/Slave Configuration20
Figure 8. Protocol syntax21
Figure 9. IIM-20670 Orientation of Axes and Polarity of Rotation33
Figure 10. Package Top and Side View33
Figure 11. Package Bottom View34
Figure 12. Part number package marking for IIM-20670.....36

LIST OF TABLES

Table 1. Gyroscope Specifications8

Table 2. Accelerometer Specifications.....9

Table 3. Temperature sensor specifications10

Table 4. D.C. Electrical Characteristics10

Table 5. A.C. Electrical Characteristics10

Table 6. Other Electrical Specifications.....11

Table 7. SPI timing definitions11

Table 8. Absolute Maximum Ratings12

Table 9. Thermal parameters.....12

Table 10. Pin Descriptions.....13

Table 11. Bill of Materials14

Table 12. Serial Interface Pins Description20

Table 13. Status bits.....21

Table 14. Z-axis Filter Configuration Parameters.....26

Table 15. Y-axis Filter Configuration Parameters.....27

Table 16. X-axis Filter Configuration Parameters28

Table 17. Accelerometer full-scale range and sensitivity31

Table 18. Gyroscope full-scale range and sensitivity31

Table 19. Package Dimensions.....35

1 INTRODUCTION

1.1 PURPOSE AND SCOPE

This document is a product specification, providing description, specifications, and design-related information on the IIM-20670 SmartIndustrial™ MotionTracking® device.

1.2 PRODUCT OVERVIEW

The IIM-20670 is a 6-axis SmartIndustrial™ MotionTracking device that combines a 3-axis gyroscope and a 3-axis accelerometer in a small 4.5x4.5x1.1 mm (24-pin DQFN) package. The IIM-20670, with its 6-axis integration, enables manufacturers to eliminate the costly and complex selection, qualification, and system level integration of discrete devices, guaranteeing optimal motion performance.

The gyroscope has user-programmable full-scale range up to ± 1966 dps with a guaranteed accuracy up to ± 300 dps. The accelerometer has a user-programmable accelerometer full-scale range of $\pm 2g$, to $\pm 65g$ with accuracy guaranteed to up to $\pm 36g$. Factory-calibrated initial sensitivity of both sensors reduces production-line calibration requirements.

Other industry-leading features include on-chip 16-bit ADCs, programmable digital filters, and embedded temperature sensors. The device features an SPI serial interface, a VDD operating range of 3.0V to 5.5V, and a separate digital IO supply, VDDIO, from 3.0V to 5.5V. Communication with all registers of the device is performed by using the SPI at 10 MHz.

By leveraging its patented and volume-proven CMOS-MEMS fabrication platform, which integrates Micro Electro-Mechanical Systems (MEMS) wafers with companion CMOS electronics through wafer-level bonding, InvenSense has driven the package size down to a footprint and thickness of 4.5x4.5x1.1 mm (24-pin DQFN), to provide a very small yet high-performance low-cost package. The device provides high robustness by supporting 10,000g shock reliability.

1.3 APPLICATIONS

- Navigation
- Platform stabilization
- Asset Tracking
- Robotics
- Industrial automation
- Smart transportation
- Agriculture and construction machinery

1.4 FEATURES

- Low accelerometer and gyroscope offset
- Low offset and sensitivity variation over temperature
- On-Chip 16-bit ADCs and Programmable Filters
- Digital-output temperature sensors
- VDD operating range of 3.0V to 5.5V
- MEMS structure hermetically sealed and bonded at wafer level
- RoHS and Green compliant

2 FEATURES

2.1 GYROSCOPE FEATURES

- Digital-output X-, Y-, and Z-axis angular rate sensors (gyroscopes) with a programmable full-scale range from ± 41 dps to ± 1966 dps and integrated 16-bit ADCs
- Digitally programmable low-pass filter
- Factory calibrated sensitivity scale factor
- Self-test

2.2 ACCELEROMETER FEATURES

- Digital-output X-, Y-, and Z-axis accelerometer with a programmable full-scale range from $\pm 2g$ to $\pm 65g$ and integrated 16-bit ADCs
- Self-test

2.3 ADDITIONAL FEATURES

- Small package: 24-pin DQFN 4.5x4.5x1.1 mm
- Minimal cross-axis sensitivity between the accelerometer and gyroscope axes
- Digital-output temperature sensor
- User-programmable digital filters for gyroscope and accelerometer
- 10,000g shock tolerant
- 10 MHz SPI interface for communicating with all registers
- MEMS structure hermetically sealed and bonded at wafer level

3 TARGET ELECTRICAL CHARACTERISTICS

3.1 GYROSCOPE SPECIFICATIONS

Typical Operating Circuit of section 4.2, VDD = 3.3V, VDDIO = 3.3V, T_A=25°C, unless otherwise noted.

PARAMETER	CONDITIONS	MIN	TYP	MAX	UNIT
Full Scale Range (See Table 18)	Accuracy guaranteed up to ±300 dps	+41		±1966	dps
Sensitivity	gyro_fs_sel=0001		50		LSB/dps
Resolution			0.02		dps
Sensitivity error at RT	25°C, XYZ axis	-0.45	0.24	0.45	%
Sensitivity variation over temperature	-40°C to 105°C, XYZ axis	-0.55	0.32	0.55	
Offset error at RT	25°C, XYZ axis	-0.7	0.35	0.7	dps
Offset variation over temperature	-40°C to 105°C, XYZ axis	-0.5	0.24	0.5	
Output noise	60 Hz filter, 25°C, XYZ axis		0.045	0.1	dps rms
Noise density ¹	25°C, XYZ axis		5.8	13	mdps/√Hz
Cross-axis sensitivity	25°C, XYZ axis	-1	0.43	1	%
Linearity	25°C, XYZ axis	-0.2	0.01	0.2	%FS

Table 1. Gyroscope Specifications

Note: All Min/Max values are either based on design or derived from characterization data based 3σ calculation. (bd. Lv)

1. Derived from RMS noise, 60 Hz filter

3.2 ACCELEROMETER SPECIFICATIONS

VDD = 3.3V, VDDIO = 3.3V, T_A=25°C, unless otherwise noted.

PARAMETER	CONDITIONS	MIN	TYP	MAX	UNIT
Full Scale Range (see table 16)	Accuracy guaranteed up to ±36g	±2		±64.5	G
Sensitivity	Full scale ± 16.384g		2000		LSB/g
Sensitivity	Full scale ±32.768g		1000		LSB/g
Sensitivity	Full Scale ±64.536g		500		LSB/g
Resolution	Full scale ± 16.384g		0.5		Mg
Resolution	Full scale ±32.768g		1.0		Mg
Resolution	Full Scale ±64.536g		2.0		Mg
Sensitivity error at RT	25°C, X and Y axes	-0.3	0.14	0.3	%
	25°C, Z axis	-0.8	0.25	0.8	
Sensitivity variation over temperature	-40°C to 105°C, X and Y axes	-0.25	0.08	0.25	%
	-40°C to 105°C, Z axis	-1	0.70	1.0	
Offset error at RT	25°C, X and Y axes	-17	6.7	17	mg
	25°C, Z axis	-45	17.3	45	
Offset variation over temperature	-40°C to 105°C, X and Y axes	-15	6.6	15	mg
	-40°C to 105°C, Z axis	-31	18.2	31	
Output noise	60 Hz filter, 25°C, XYZ axis		1.0	2.5	mg rms
Noise Density ¹	25°C, XYZ axis		130	325	μg/√Hz
Cross-axis sensitivity	25°C, XYZ axis	-1.0	0.6	1.0	%
Linearity	25°C, XYZ axis	-0.6	0.5	0.6	%FS

Table 2. Accelerometer Specifications

Note: All Min/Max values are either based on design or derived from characterization data based 3σ calculation. (bd. Lv)

1. Derived from RMS noise, 60 Hz filter

3.3 TEMPERATURE SENSOR SPECIFICATIONS

VDD = 3.3V, VDDIO = 3.3V, T_A=25°C, unless otherwise noted.

PARAMETER	CONDITIONS	MIN	TYP	MAX	UNIT
Total offset error	Including all variations (over life, temperature, supply, etc.)	-10		10	K
Sensitivity			20		LSB/°C
Total Sensitivity error	Including all variations (over life, temperature, supply, etc.)	-5.0		5.0	%
Linearity	-40°C to 105°C	-2.0		2.0	%

Table 3. Temperature sensor specifications

Note: All Min/Max values are either based on design or derived from characterization data based 3 σ calculation.

3.4 ELECTRICAL SPECIFICATIONS

3.4.1 D.C. Electrical Characteristics

Typical Operating Circuit of section 4.2, VDD = 3.3V, VDDIO = 3.3V, T_A=25°C, unless otherwise noted.

PARAMETER	CONDITIONS	MIN	TYP	MAX	UNITS	NOTES
SUPPLY VOLTAGES						
VDD	3.3V supply range	3.0	3.3	3.6	V	1
	5.0V supply range	4.5	5.0	5.5	V	1
VDDIO	3.3V supply range	3.0	3.3	3.6	V	1
	5.0V supply range	4.5	5.0	5.5	V	1
VPP	Connect to VDDIO	VDDIO-0.3		VDDIO+0.3	V	1
SUPPLY CURRENTS & BOOT TIME						
Normal Mode	6-axis Gyroscope + Accelerometer			10	mA	1
TEMPERATURE RANGE						
Specified Temperature Range	Performance parameters are not applicable beyond Specified Temperature Range	-40		+105	°C	1

Table 4. D.C. Electrical Characteristics

Note: 1. Based on simulation and characterization of parts.

3.4.2 A.C. Electrical Characteristics

Typical Operating Circuit of section 4.2, VDD = 3.3V, VDDIO = 3.3V, T_A=25°C, unless otherwise noted.

PARAMETER	CONDITIONS	MIN	TYP	MAX	UNITS	NOTES
SUPPLIES						
Supply Ramp Time (T _{RAMP})	Monotonic ramp. Ramp rate is 10% to 90% of the final value	0.01		100	ms	1
POWER-ON RESET						
Supply Ramp Time (T _{RAMP})	Valid power-on RESET	0.01		100	ms	1
Start-up time for register read/write	From power-up			200	ms	1
DIGITAL INPUTS (MOSI, NCS, SCLK, RESETN)						
V _{IH} , High-Level Input Voltage		0.55*VDDIO		VDDIO+0.3	V	1
V _{IL} , Low-Level Input Voltage		-0.3		0.3*VDDIO	V	
C _i , Input Capacitance				15	pF	
DIGITAL OUTPUT (MISO)						
V _{OH} , High- Level Output Voltage	I _{out} =-1 mA	DVDD-0.5		VDD+0.3	V	1
V _{OL} , Low-Level Output Voltage	I _{out} =1 mA			0.5	V	

Table 5. A.C. Electrical Characteristics

Note: 1. Derived from validation or characterization of parts, not guaranteed in production.

3.4.3 Other Electrical Specifications

Typical Operating Circuit of section 4.2, VDD = 3.3V, VDDIO = 3.3V, TA=25°C, unless otherwise noted.

PARAMETER	CONDITIONS	MIN	TYP	MAX	UNITS	NOTES
SPI Operating Frequency, All Registers Read/Write			10000		kHz	1
SPI mode			0			
Internal sampling rate		8,000			Samples/s	1, 2

Table 6. Other Electrical Specifications

Note:

1. Derived from validation or characterization of parts, not guaranteed in production.
2. If output data are acquired at a frequency different than the effective actual data rate, a suitable sampling rate conversion processing should be applied by the receiver to prevent data corruption by aliasing/images.

3.5 SPI TIMING CHARACTERIZATION

NO.	PARAMETER	MIN	MAX	DESCRIPTION
	f_{SPI}		10 MHz	SCLK Frequency
1	t_{high}	35 ns		Time high: duration of SCLK logical high level
2	t_{low}	35 ns		Time low: duration of SCLK logical low level
3	t_{SUCS}	35 ns		CSB setup time: time between the CSB falling edge and SCLK rising edge
4	t_{d1}		52 ns	Time between CSB falling edge to valid data on MISO with 100 pF capacitance at MISO
5	t_{susi}	12 ns		MOSI setup time (with respect to an SCLK rising edge)
6	t_{d2}	0 ns	52 ns	Time between SCLK falling edge to valid data on MISO with 100 pF capacitance at MISO
7	t_{ncs}	20 ns		CSB hold time (SCLK falling edge to CSB rising edge)
8	t_{ri}		44 ns	Time between CSB rising edge to MISO tri-state with 200 pF capacitance at MISO
9	t_{ihics}	35 ns		Minimum time that CSB must stay high between two consecutive transfers
10	t_{ckrh}	10 ns		SCLK hold time after CSB becomes high
11	t_{ckfh}	5 ns		SCLK hold time after CSB becomes low
12	t_{cks}		4 ns	SCLK rise time
13	t_{ckf}		4 ns	SCLK fall time
14	t_{hsi}	12 ns		MOSI hold time before an SCLK falling edge

Table 7. SPI timing definitions

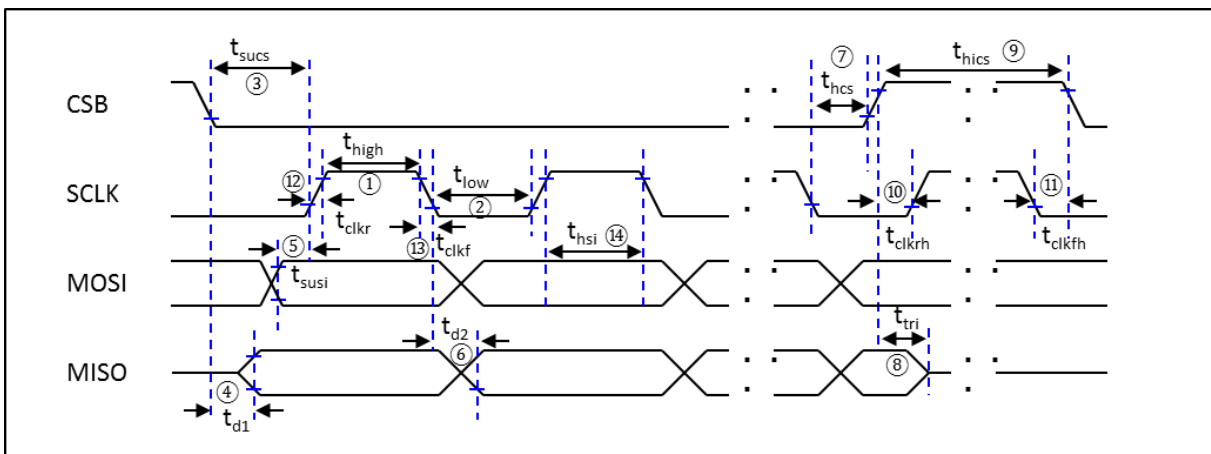

Figure 1. SPI bus timing diagram

3.6 ABSOLUTE MAXIMUM RATINGS

Stress above those listed as “Absolute Maximum Ratings” may cause permanent damage to the device. These are stress ratings only and functional operation of the device at these conditions is not implied. Exposure to the absolute maximum ratings conditions for extended periods may affect device reliability.

PARAMETER	RATING
Supply Voltage, VDD	-0.3V to 6.5V
Supply Voltage, VDDIO	-0.3V to 6.5V
Input Voltage Level (MOSI, CSB, SCLK)	-0.5V to VDDIO + 0.5V
Acceleration (Any Axis, unpowered)	10,000g for 0.2 ms
Constant vibration (amplitude and frequency)	200 g, 43kHz
Operating Temperature Range	-40°C to 105°C
Storage Temperature Range	-40°C to 155°C
Electrostatic Discharge (ESD) Protection Human Body Model (HBM)	2 kV
ESD Protection HBM (GND/Power Pins)	4 kV
ESD Protection Charged Device Model (CDM)	500V
ESD Protection CDM (Corner Pins)	750V
Latch-up at 105°C	±200 mA
Ultrasonic excitation (cleaning/welding/...)	Not allowed

Table 8. Absolute Maximum Ratings

Note:

1. Details for frequency higher than 43 kHz provided upon request

3.7 THERMAL INFO

THERMAL METRIC	DESCRIPTION	VALUE	UNIT
θ_{JA}	Junction-to-ambient thermal resistance	45.94	°C/W
Ψ_{JT}	Thermal Characterization Parameter Junction-to-Top	4.31	°C/W
Ψ_{JB}	Thermal Characterization Parameter Junction-to-Board	21.82	°C/W

Table 9. Thermal parameters

Definitions according to Figure 2.

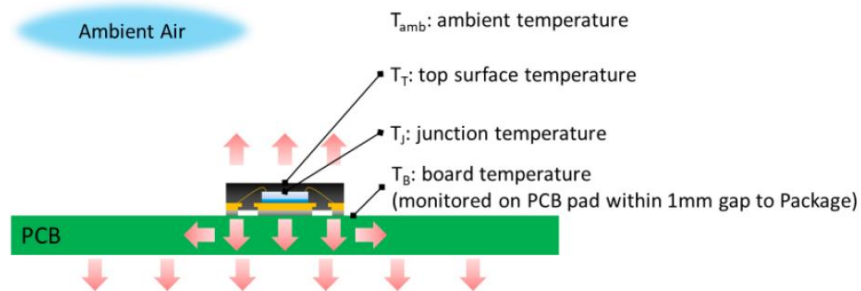

Figure 2. Thermal parameters characterization points

Test condition:

TSP/K factor measurement according to JESD51-1.

Thermal resistance θ_{JA} in still air according to JESD51-2A.

PCB designed accordingly JESD51-7

4 APPLICATIONS INFORMATION

4.1 PINOUT DIAGRAM AND SIGNAL DESCRIPTION

PIN NUMBER	PIN NAME	PIN DESCRIPTION
1	MOSI	Connect to host SPI MOSI pin
7	GND	Ground pin
8	VDDIO	VDDIO rail (3.3V or 5V)
9	MISO	Connect to host SPI MISO pin
10	REGOUT	Connect to ground through a 100 nF capacitor
11	VDD	Connect to 5V or 3.3V supply voltage and decouple with a 100 nF capacitor
12	ODR	Output Data-ready for synchronous sensor data readings (optional), leave floating when not used
18	RESETN	Connect to host reset signal (active low) or to VDDIO
20	VPP	Connect to VDDIO
23	NCS	Connect to host CS pin
24	SCLK	Connect to host SPI SCLK pin
6, 13, 19, 21	FL	Leave floating
2, 3, 4, 5, 14, 15, 16, 17, 22	GND	Connect to ground

Table 10. Pin Descriptions

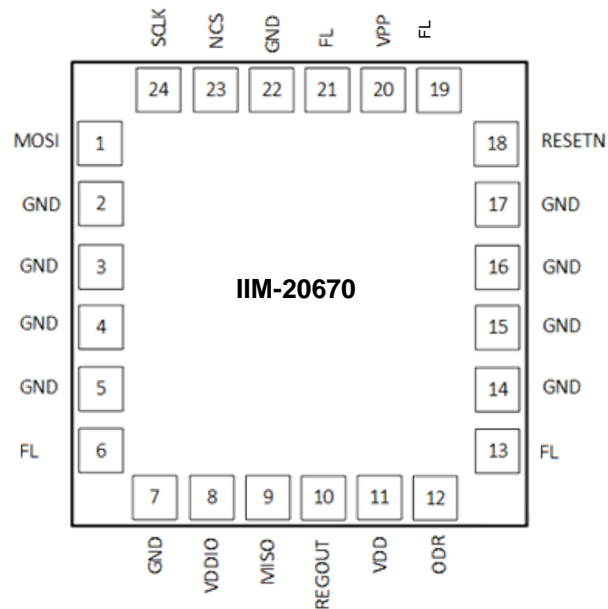

Figure 3. Top View – DQFN package 24-pin 4.5 mm x 4.5 mm x 1.1 mm

4.2 TYPICAL OPERATING CIRCUIT

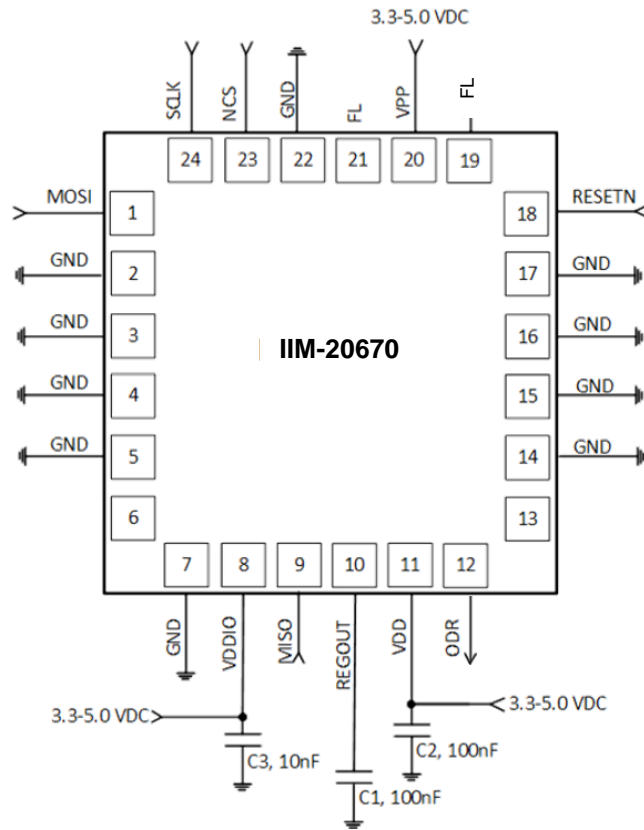

Figure 4. Application Schematic

4.3 BILL OF MATERIALS FOR EXTERNAL COMPONENTS

COMPONENT	LABEL	SPECIFICATION	QUANTITY
REGOUT Capacitor	C1	X7R, 100 nF ±10%	1
VDD Bypass Capacitors	C2	X7R, 100 nF ±10%	1
VDDIO Bypass Capacitor	C3	X7R, 10 nF ±10%	1

Table 11. Bill of Materials

4.4 BLOCK DIAGRAM

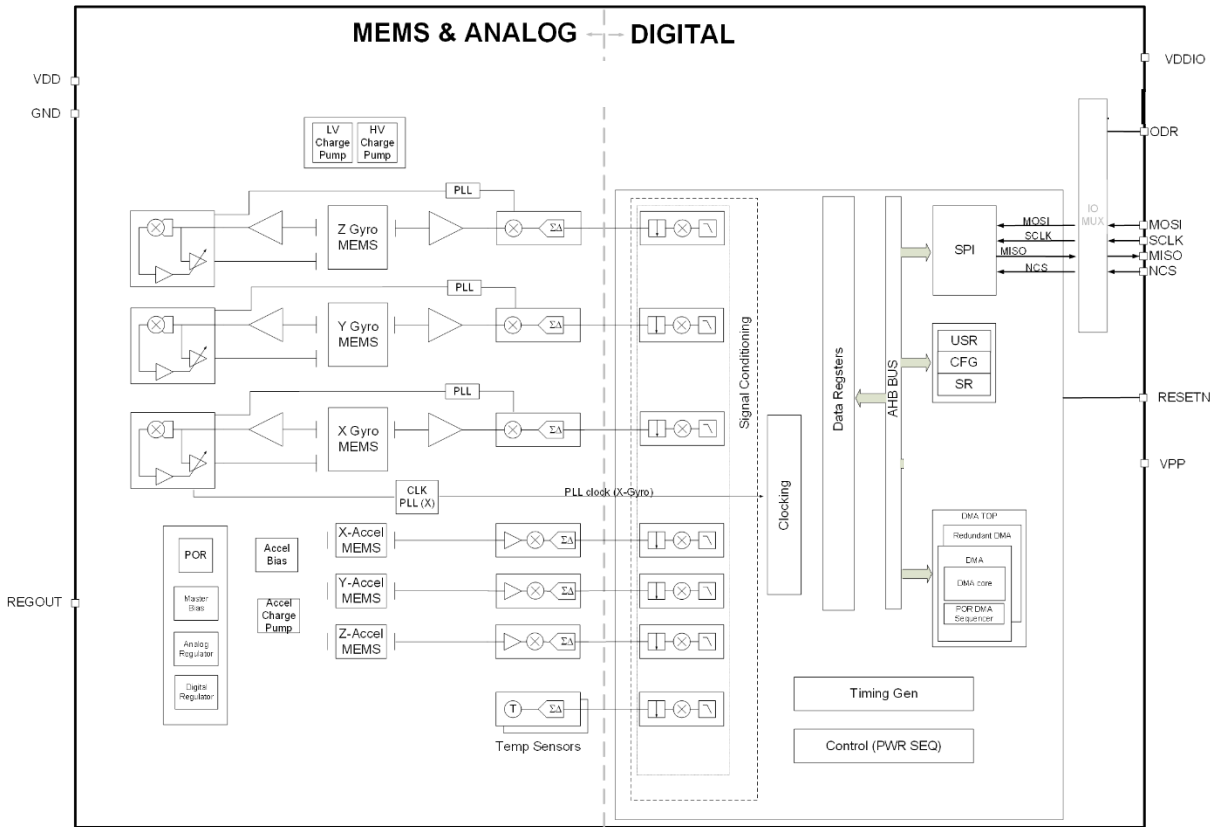

Figure 5. IIM-20670 Block Diagram

4.5 OVERVIEW

The IIM-20670 is comprised of the following key blocks and functions:

- Three-axis MEMS rate gyroscope sensor with 16-bit ADCs and signal conditioning
- Three-axis MEMS accelerometer sensor with 16-bit ADCs and signal conditioning
- Digital-output temperature sensors
- SPI serial communications interface
- Self-test
- Clocking
- Sensor Data Registers
- Bias circuit, regulators, charge pumps, and supplies
- Startup circuitry
- Signal conditioning and digital low-pass filters

4.6 SIGNAL CONDITIONING AND FILTERING

The capacitive output of the MEMS gyroscopes and accelerometers is converted into a digital representation by six sigma-delta analog-to-digital converters (ADCs – one converter per MEMS structure). Also, the output of each temperature sensor is converted into a digital value by a sigma-delta ADC. A bandgap structure provides the reference voltage to each ADC. The bitstream in output of the sigma-delta ADCs is then fed to a gain offset settings (GOS) block that applies all the compensations and calibrations. The output of the GOS block is fed to digital low-pass filters (see sections 6.7 and 6.8). The output of the filters is available in the output registers (see sections 6.1 to 6.5).

4.7 THREE-AXIS MEMS GYROSCOPE WITH 16-BIT ADCS AND SIGNAL CONDITIONING

The IIM-20670 consists of three independent vibratory MEMS rate one-axis gyroscopes which detect the rotation around the X, Y, and Z axes. When the gyroscopes are rotated around any of the sense axes, the Coriolis Effect causes a vibration that is detected by a capacitive pickoff. The resulting signal is amplified, demodulated, and filtered to produce a voltage that is proportional to the angular rate. This voltage is digitized using individual on-chip 16-bit ADCs to sample each axis. A digital signal processor (DSP) processes the ADC output signals and reports the result into the gyroscope output registers. The gyroscopes are driven by dedicated drive circuits. The ADC sample rate is 8,000 samples per second (gyroscope, accelerometer, and temperature data will all be sampled within a sample period). User-selectable filters enable a wide range of cut-off frequencies.

The full-scale range of the digital outputs can be adjusted setting the register `gyro_fs_sel[2:0]` (see section 6.17).

4.7.1 Gyroscope Output

The registers `gyro_x_data[15:0]`, `gyro_y_data[15:0]`, and `gyro_z_data[15:0]` contain the gyroscope data for the x, y, and z axis respectively. The registers are encoded in 2's complement and the equation to convert the digital output into the corresponding angular rotation rate is:

$$\omega_x = \frac{\text{gyro_x_data}}{2^{15}} * FS, \omega_y = \frac{\text{gyro_y_data}}{2^{15}} * FS, \omega_z = \frac{\text{gyro_z_data}}{2^{15}} * FS,$$

Where $\omega_x, \omega_y, \omega_z$ are the angular rates of rotation (expressed in dps) of the axes x, y, and z, respectively and FS is the full-scale value of the axis. For instance, if `gyro_x_data[15:0]` contains 0x0A17 (Decimal 2583) and `gyro_fs_sel[3:0]=5`, the angular rate of the x axis is $2583 * 655.36 / 2^{15} = 51.63$ dps.

4.8 THREE-AXIS MEMS ACCELEROMETER WITH 16-BIT ADCS AND SIGNAL CONDITIONING

The IIM-20670's 3-axis accelerometer uses separate proof masses for each axis. Acceleration along a particular axis induces displacement on the corresponding proof mass and capacitive sensors detect the displacement differentially. The IIM-20670's architecture reduces the accelerometers' susceptibility to manufacturing variations as well as to thermal drift. The accelerometers' scale factor is calibrated at the factory and is nominally independent of supply voltage. Each sensor has a dedicated sigma-delta ADC for providing digital outputs. A DSP processes the signals at the output of the ADCs and reports the result into the accelerometer output registers. The IIM-20670 provides two accelerometer outputs per axis: a high-resolution output and a low-resolution output. The two outputs only differ for the full-scale setting (and, hence, for the resolution). The full-scale range of the high-resolution output is always smaller than the full-scale range of the low-resolution output.

The full-scale range of the digital outputs can be adjusted setting the register `accel_fs_sel[2:0]` (see sections 6.17).

4.8.1 Accelerometers Output

The registers `accel_x_data[15:0]`, `accel_y_data[15:0]`, and `accel_z_data[15:0]` contain the accelerometer data for the axes x, y, and z respectively. The registers `accel_x_data_lr[15:0]`, `accel_y_data_lr[15:0]`, and `accel_z_data_lr[15:0]` contain the low-resolution accelerometer data for the axes x, y, and z respectively. The low-resolution registers are designated with the suffix "lr". The registers are encoded in 2's complement and the equation to convert the digital output into the corresponding acceleration is:

$$a_x = \frac{\text{accel_x_data}}{2^{15}} * FS, a_y = \frac{\text{accel_y_data}}{2^{15}} * FS, a_z = \frac{\text{accel_z_data}}{2^{15}} * FS,$$

$$a_{lr_x} = \frac{\text{accel_x_data_lr}}{2^{15}} * FS_{lr}, a_{lr_y} = \frac{\text{accel_y_data_lr}}{2^{15}} * FS_{lr}, a_{lr_z} = \frac{\text{accel_z_data_lr}}{2^{15}} * FS_{lr},$$

Where $a_x, a_y, a_z, a_{lr_x}, a_{lr_y},$ and a_{lr_z} are the high-resolution and low-resolution accelerations of the axes x, y, and z, respectively and FS and FS_{lr} the full-scale range of the accelerometers high-resolution and low-resolution output. Table 16 shows the relationship between `accel_fs_sel` and the full-scale ranges.

For instance, if `accel_x_data[15:0]` contains 0x0A17 (Decimal 2583) and `accel_fs_sel[2:0]` is 001 (± 16.384 g), the acceleration of the x axis is $2583 * (16.384 \text{ g}) / 2^{15} = 1.291\text{g}$.

4.9 TEMPERATURE SENSORS

The IIM-20670 contains two temperature sensors called temp1 and temp2. Temperature sensor temp1 is used by all temperature-related calculations, while temp2 is used to check the correct operation of temp1. The output of the two temperature sensors is available in the registers temp1_data[15:0] and temp2_data[15:0], respectively. The equation to convert the digital output into the corresponding temperature (expressed in degrees Celsius) is:

$$TEMPERATURE (^{\circ}C) = 25 + \frac{temp_data}{20}$$

where temp_data indicates either temp1_data[15:0] or temp2_data[15:0].

4.10 SERIAL COMMUNICATIONS INTERFACE

The IIM-20670 communicates with a system processor using a SPI interface. The IIM-20670 always acts as a slave when communicating to the system processor.

The system processor is an SPI master to the IIM-20670. Pins 1, 9, 23, 24 are used to support the MOSI, MISO, NCS, and SCLK signals for SPI communications. See section 5 for more information on the communication interface.

SPI readings are driven by SCLK that is asynchronous respect to internal sensor data rate (8 kHz). When required it’s possible to synchronize SPI readings with internal ODR clock.

4.11 SPI READINGS SYNCHRONOUS WITH INTERNAL ODR

Pin 12 (ODR) can be programmed to generate a copy of internal output data rate, allowing the synchronization of SPI readings respect to internal sensor data generation. Once programmed the ODR clock on pin 12, SPI readings shall be executed following timing shown in the following diagram:

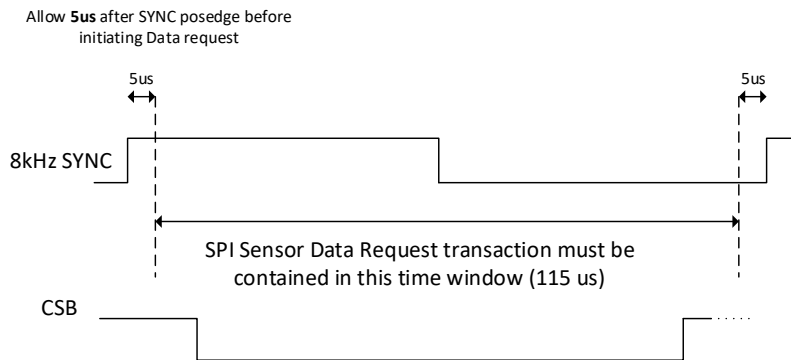

Figure 6: SPI synchronization with ODR

IIM-20670 implements a security feature to prevent unwanted register change, below procedure must be applied in order to unlock the ODR feature:

- 32-bit HEX word command must be sent over SPI: 0xE400288
- 32-bit HEX word command must be sent over SPI: 0xE40018B
- 32-bit HEX word command must be sent over SPI: 0xE400048E
- 32-bit HEX word command must be sent over SPI: 0xE40300AD
- 32-bit HEX word command must be sent over SPI: 0xE4018017
- 32-bit HEX word command must be sent over SPI: 0xE4028030

Once the procedure above has been completed the ODR clock can be routed on Pin 12 following below procedure:

- Set BANK3, register address 0x14, bit 9 to 1b
- Set BANK3, register address 0x17, bit 12 to 1b
- Set BANK3, register address 0x11, bits 13:8 to 0x21
- Set BANK3, register address 0x13, bits 7:4 to 0x08
- Set BANK3, register address 0x14, bit 5 to 1b
- Set BANK3, register address 0x16, bit 0 to 1b

Please note that all the other bits that are contained into the same registers must be considered reserved and changing them might cause unwanted effects. To avoid unwanted behavior of the chip, before writing into a 16-bit register, read the whole 16-bit register first and compute the new register value by changing the desired bits only.

4.12 SELF-TEST

Self-test allows for the testing of the mechanical and electrical portions of the sensors. The Accelerometer and the Gyroscope can be tested independently by applying a set of electrostatic forces to movable structures through dedicated electrodes. When the self-test is activated, the electronics cause the sensors to be actuated and produce an output signal. When the value of the self-test response is within the specified min/max limits of the product specification, the part has passed self-test. When the self-test response exceeds the min/max values, the part is deemed to have failed self-test.

The self-test for accelerometer can be activated by setting the register `accel_dc_trigger`. In this case, the self-test will be executed with a stimulus equivalent to a variation of -3g or +3g, depending upon the setting of `accel_dc_trigger`. The output per axis can be read from `accel_x_data`, `accel_y_data`, and `accel_z_data` after 20ms. For example, if the difference between `accel_x_data` for +3g stimulus (`FS_SEL=001`) and for -3g stimulus (`FS_SEL=001`) is within 4.2g (LSL – Lower Specification Limit) and 7.8g (USL- Upper Specification Limit), the self test has passed for Accel X-axis. Please note that RS bits (SPI Return Status) would be set to '10' when the `accel_data` registers are read while self-test is enabled.

The self-test for Gyro can be activated manually by setting the register `gyro_dc_trigger`. In this case, the self-test will be executed with a stimulus equivalent to -110dps or +110dps, depending upon the setting of `gyro_dc_trigger`. The output per axis can be read from `gyro_x_data`, `gyro_y_data`, and `gyro_z_data` after 20ms. For example, if the difference between `gyro_x_data` for +110dps stimulus (`FS_SEL=001`) and for -110dps stimulus (`FS_SEL=001`) is within 154dps (LSL – Lower Specification Limit) and 286dps (USL- Upper Specification Limit), the self test has passed for Gyro X-axis. Please note that RS bits (SPI Return Status) would be set to '10' when the `gyro_data` registers are read while self-test is enabled.

4.13 CLOCKING

The IIM-20670 system is normally clocked by a phase locked loop (PLL). At start-up, until the PLL is stable, the IIM-20670 is clocked by an internal RC relaxation oscillator (RCOSC1).

Each gyroscope has its own separate PLL.

4.14 SENSOR DATA REGISTERS

The sensor data registers contain the latest gyroscope, accelerometer, and temperature measurement data. They are read-only registers and are accessed via the serial interface. Data from these registers may be read at any time. See sections 6.1 to 6.5 for details.

4.15 BIAS, REGULATORS, REFERENCES, CHARGE PUMPS, AND SUPPLIES

The bias and LDO block generate the internal supply and the reference voltages and currents required by the IIM-20670. The IIM-20670 is powered externally by two 3.3V to 5V (nominal) supplies, VDD and VPP, and by an input/output supply VDDIO that powers the communications output driver and determines the voltage levels of the SPI interface.

The IIM-20670 contains a number of regulators that, along with the charge pump, generate the required internal voltages, including the 2.4V master regulator, the 1.8V analog supply, AVDD, and the 1.8V digital supply, DVDD. The regulators and charge pumps contain a series of voltage references, each of which includes one or more bandgaps.

On-chip charge pumps generate the voltages required for the MEMS element.

4.16 INTERNAL BUSES

The IIM-20670 has internal direct memory access (DMA) and Advanced Microcontroller Bus Architecture (AMBA) High Performance (AHB) buses that route the signals between the registers and other internal blocks.

5 DIGITAL INTERFACE

The IIM-20670 uses a Serial Peripheral Interface to communicate with the host processor.

5.1 SERIAL INTERFACE PIN DESCRIPTIONS

The internal registers and memory of the IIM-20670 can be accessed using a SPI interface at 10 MHz. SPI operates in four-wire mode.

PIN NUMBER	PIN NAME	PIN DESCRIPTION
1	MOSI	Master Output Slave Input
9	MISO	Master Input Slave Output
23	NCS	Chip Select
24	SCLK	Serial Clock

Table 12. Serial Interface Pins Description

5.1.1 SPI Interface Operation

SPI is a 4-wire synchronous serial interface that uses two control lines and two data lines. The IIM-20670 always operates as a slave device during standard master-slave SPI operation. The IIM-20670 only supports SPI mode 0.

With respect to the master, MOSI, MISO, and SCLK are shared among the slave devices. Each SPI slave device requires its own Chip Select (NCS) line from the master.

NCS goes low (active) at the start of transmission and goes back high (inactive) at the end. Only one chip select line is active at any given time, ensuring that only one slave is selected at any given time. The CS lines of the non-selected slave devices are held high, causing their MISO lines to remain in a high-impedance (high-Z) state so that they do not interfere with any active devices.

SPI Operational Features

1. Data are delivered MSB first and LSB last
2. Data are latched on the rising edge of SCLK
3. Data should be transitioned on the falling edge of SCLK
4. The maximum frequency of SCLK is 10 MHz

SPI read and write operations are completed in 32 clock cycles.

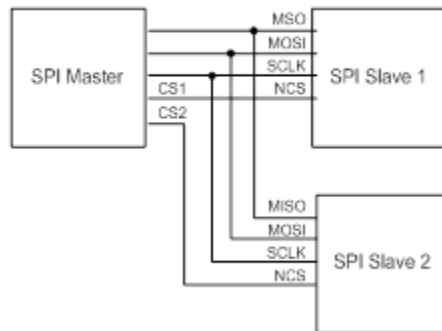

Figure 7. Typical SPI Master/Slave Configuration

5.2 PROTOCOL

The protocol is a 32-bit communication protocol. The bits are arranged according to the order shown in Figure 8.

	b31	b30	b29	b28	b27	b26	b25	b24	b23	b22	...	b8	b7	...	b0
	Offset						Return status		Data				CRC		
MOSI	RW	A4	A3	A2	A1	A0	0	0	D15	D14	...	D0	CR7	...	CR0
MISO	RW	A4	A3	A2	A1	A0	RS1	RS0	D15	D14	...	D0	CR7	...	CR0

Figure 8. Protocol syntax

Each SPI command allows to read or write a register in the currently selected bank. Bank 0 is selected by default. To change bank, the host controller must first unlock bank_select (see section 6.15) using the tcode_status sequence shown in section 6.13.

Bit 31 determines whether the command is a register read (0) or a register write (1). Bits [30:26] represent the offset with respect to the bank that is currently selected. Please note that offsets 0x00 to 0x07 contain gyroscope, accelerometer, and sensors output data in all banks (see sections 6.1, 6.2, 6.3, and 6.4).

The meaning of the status bits is shown in Table 13.

RS1	RS0	Definition
0	0	Reserved
0	1	Successful Register read/write
1	0	Register read/write in progress (data not prepared) or Sensor output register read while self-test enabled
1	1	Error

Table 13. Status bits

When communicating through SPI, data integrity is checked using an error-detecting code algorithm similar to the classic CRC, with 0xFF seed value. Please note that the resulting code is inverted before being appended to the command. For instance, when sending 0xD07A65, the inverted code is 0x88 and the host controller should send 0xD07A6588. Input_data is the 24-bit word to be encoded, shifted serially, most significant bit first.

```
# encoding algorithm
CRC=0xFF
CRC_New=0x00
For i=23 to 0 {
  CRC_New[7]=CRC[6]
  CRC_New[6]=CRC[5]
  CRC_New[5]=CRC[4]
  CRC_New[4]=CRC[3] ^CRC[7]
  CRC_New[3]=CRC[2] ^CRC[7]
  CRC_New[2]=CRC[1] ^CRC[7]
  CRC_New[1]=CRC[0]
  CRC_New[0]=Input_data[i]^CRC[7]
  CRC=CRC_New
}

# final inversion before appending
For i=0 to 7 {
  CRC[i] = CRC[i]^1
}
```

The symbol ^ indicates the XOR operator.

For example, the CRC of 0xA0CA85 is 2F and the CRC of 0x3B007C is C2.

5.3 SPI COMMANDS FOR ACCELEROMETER SELF-TEST

The en_accel_selftest bits should be set to 1 prior to executing the following steps.

COMMANDS (FS_SEL=001 or 010 or 011)		SPI			
		RW-ADDR-RS-DATA			CRC
#0	Send SPI command to set Bank0	FC	00	00	64
#1	send SPI command for DC self-test positive accel_dc_trigger[1:0]=01	D8	00	08	34
#2	wait 20ms				
#3	send SPI command to address ACCEL_X_DATA	10	00	00	45
#4	send SPI command to address ACCEL_Y_DATA and read ACCEL_X_DATA on MISO (RS bits would be 10)	14	00	00	68
#5	send SPI command to address ACCEL_Z_DATA and read ACCEL_Y_DATA on MISO (RS bits would be 10)	18	00	00	1F
#6	send SPI dummy command to read ACCEL_Z_DATA on MISO (RS bits would be 10)	5C	00	00	d8
#7	ACCEL_X_DATA_pos = ACCEL_X_DATA				
#8	ACCEL_Y_DATA_pos = ACCEL_Y_DATA				
#9	ACCEL_Z_DATA_pos = ACCEL_Z_DATA				
#10	send SPI command for DC self-test negative accel_dc_trigger[1:0]=10	D8	00	10	2C
#11	wait 20ms				
#12	send SPI command to address ACCEL_X_DATA	10	00	00	45
#13	send SPI command to address ACCEL_Y_DATA and read ACCEL_X_DATA on MISO (RS bits would be 10)	14	00	00	68
#14	send SPI command to address ACCEL_Z_DATA and read ACCEL_Y_DATA on MISO (RS bits would be 10)	18	00	00	1F
#15	send SPI dummy command to read ACCEL_Z_DATA on MISO (RS bits would be 10)	5C	00	00	D8
#16	ACCEL_X_DATA_neg = ACCEL_X_DATA				
#17	ACCEL_Y_DATA_neg = ACCEL_Y_DATA				
#18	ACCEL_Z_DATA_neg = ACCEL_Z_DATA				
#19	compare ACCEL_X_DATA_pos - ACCEL_X_DATA_neg (nominal 6g) vs LSL=4.2g and USL=7.8g				
#20	compare ACCEL_Y_DATA_pos - ACCEL_Y_DATA_neg (nominal 6g) vs LSL=4.2g and USL=7.8g				
#21	compare ACCEL_Z_DATA_pos - ACCEL_Z_DATA_neg (nominal 6g) vs LSL=4.2g and USL=7.8g				
#22	send SPI command for DC self-test reset accel_dc_trigger[1:0]=00	D8	00	00	3C
#23	wait 20ms				

5.4 SPI COMMANDS FOR GYROSCOPE SELF-TEST

The en_gyro_selftest bits should be set to 1 prior to executing the following steps.

COMMANDS (FS_SEL=001 or 010 or 011)		SPI			
		RW-ADDR-RS-DATA			CRC
#0	Send SPI command to set Bank0	FC	00	00	64
#1	send SPI command for DC self-test positive gyro_dc_trigger[1:0]=01	D8	00	80	BC
#2	wait 20ms				
#3	send SPI command to address GYRO_X_DATA	00	00	00	F1
#4	send SPI command to address GYRO_Y_DATA and read GYRO_X_DATA on MISO (RS bits would be 10)	04	00	00	DC
#5	send SPI command to address GYRO_Z_DATA and read GYRO_Y_DATA on MISO (RS bits would be 10)	08	00	00	AB
#6	send SPI dummy command to read GYRO_Z_DATA on MISO (RS bits would be 10)	5C	00	00	D8
#7	GYRO_X_DATA_pos = GYRO_X_DATA				
#8	GYRO_Y_DATA_pos = GYRO_Y_DATA				
#9	GYRO_Z_DATA_pos = GYRO_Z_DATA				
#10	send SPI command for DC self-test negative gyro_dc_trigger[1:0]=10	D8	01	00	21
#11	wait 20ms				
#12	send SPI command to address GYRO_X_DATA	00	00	00	F1
#13	send SPI command to address GYRO_Y_DATA and read GYRO_X_DATA on MISO (RS bits would be 10)	04	00	00	DC
#14	send SPI command to address GYRO_Z_DATA and read GYRO_Y_DATA on MISO (RS bits would be 10)	08	00	00	AB
#15	send SPI dummy command to read GYRO_Z_DATA on MISO (RS bits would be 10)	5C	00	00	D8
#16	GYRO_X_DATA_neg = GYRO_X_DATA				
#17	GYRO_Y_DATA_neg = GYRO_Y_DATA				
#18	GYRO_Z_DATA_neg = GYRO_Z_DATA				
#19	compare GYRO_X_DATA_pos - GYRO_X_DATA_neg (nominal 220dps) vs LSL=154dps and USL=286dps				
#20	compare GYRO_Y_DATA_pos - GYRO_Y_DATA_neg (nominal 220dps) vs LSL=154dps and USL=286dps				
#21	compare GYRO_Z_DATA_pos - GYRO_Z_DATA_neg (nominal 220dps) vs LSL=154dps and USL=286dps				
#22	send SPI command for DC self-test reset gyro_dc_trigger[1:0]=00	D8	00	00	3C
#23	wait 20ms				

6 REGISTER DESCRIPTIONS

This section describes the function and contents of each register within the IIM-20670. The registers are described in order of bank and, within each bank, in order of offset.

Please note that all register bits that are not documented are considered reserved and changing them might cause unwanted effects. To avoid unwanted behavior of the chip, before writing into a 16-bit register, read the whole 16-bit register first and compute the new register value by changing the desired bits.

6.1 GYROSCOPE DATA

TYPE	BANK	OFFSET	BIT	DEFAULT	NAME	FUNCTION
R	All	0x00	15:0	N/A	gyro_x_data[15:0]	Contains the gyroscope x axis data
R	All	0x01	15:0	N/A	gyro_y_data[15:0]	Contains the gyroscope y axis data
R	All	0x02	15:0	N/A	gyro_z_data[15:0]	Contains the gyroscope z axis data

The registers gyro_x_data[15:0], gyro_y_data[15:0], and gyro_z_data[15:0] contain the gyroscope data for the axes x, y, and z respectively. The registers are encoded in 2's complement. Refer to section 4.7.1 for details on how to convert the register output in degrees per second.

6.2 TEMPERATURE 1 DATA

TYPE	BANK	OFFSET	BIT	DEFAULT	NAME	FUNCTION
R	All	0x03	15:0	N/A	temp1_data[15:0]	Contains the temperature sensor 1 data

The register temp1_data[15:0] contains the IC temperature data. The register is encoded in 2's complement. See section 4.9 for the equation to convert the digital output into the corresponding temperature (expressed in degrees Celsius).

6.3 ACCELEROMETER DATA

TYPE	BANK	OFFSET	BIT	DEFAULT	NAME	FUNCTION
R	All	0x04	15:0	N/A	accel_x_data[15:0]	Contains the accelerometer x axis data
R	All	0x05	15:0	N/A	accel_y_data[15:0]	Contains the accelerometer y axis data
R	All	0x06	15:0	N/A	accel_z_data[15:0]	Contains the accelerometer z axis data

The registers accel_x_data, accel_y_data, and accel_z_data contain the accelerometer data for the axes x, y, and z respectively. The registers are encoded in 2's complement. Refer to section 4.8.1 for details on how to convert the register output in g.

6.4 TEMPERATURE 2 DATA

TYPE	BANK	OFFSET	BIT	DEFAULT	NAME	FUNCTION
R	All	0x07	15:0	N/A	temp2_data[15:0]	Contains the temperature sensor 2 data

The register temp2_data[15:0] contains the temperature data for the redundant temperature. The register encoding and behavior matches that of temp1_data[15:0].

6.5 LOW RESOLUTION ACCELEROMETER DATA

TYPE	BANK	OFFSET	BIT	DEFAULT	NAME	FUNCTION
R	0	0x08	15:0	N/A	accel_x_data_lr[15:0]	Contains the low-resolution accelerometer x axis data
R	0	0x09	15:0	N/A	accel_y_data_lr[15:0]	Contains the low-resolution accelerometer y axis data
R	0	0x0A	15:0	N/A	accel_z_data_lr[15:0]	Contains the low-resolution accelerometer z axis data

The registers accel_x_data_lr, accel_y_data_lr, and accel_z_data_lr contain the accelerometer data for the axes x, y, and z respectively. The register suffix LR stands for "low resolution" as its full scale is always equal or greater than that of the accelerometer data registers of section 6.3. The registers are encoded in 2's complement. Refer to section 4.8.1 for details on how to convert the register output in g.

6.6 FIXED VALUE

TYPE	BANK	OFFSET	BIT	DEFAULT	NAME	FUNCTION
R	0	0x0B	15:0	0xAA55	fixed_value[15:0]	Fixed value 0xAA55

6.7 ACCELEROMETER AND GYROSCOPE Y AND Z FILTER SETTINGS

TYPE	BANK	OFFSET	BIT	DEFAULT	NAME	FUNCTION
RW	0	0x0C	5:0	100000	flt_y[5:0]	Output filter setting for the gyroscope's and accelerometer's y axis.
RW	0	0x0C	11:6	100000	flt_z[5:0]	Output filter setting for the gyroscope's and accelerometer's z axis.

The registers flt_y and flt_z contain the settings for the filters in front of the gyroscope and accelerometer for axes y and z. The filters are set according to Table 13 and Table 14 (all settings not documented in the table are reserved).

FLT_Z						CUT-OFF FREQUENCY [HZ]	
D11	D10	D9	D8	D7	D6	GYRO_Z	ACCEL_Z
0	0	0	0	0	1	10	10
0	0	0	0	1	0	10	46
0	0	0	0	1	1	10	60
0	0	0	1	0	0	10	250
0	0	0	1	0	1	10	300
0	0	0	1	1	0	10	400
0	0	0	1	1	1	12.5	10
0	0	1	0	0	0	12.5	46
0	0	1	0	0	1	12.5	60
0	0	1	0	1	0	12.5	250
0	0	1	0	1	1	12.5	300
0	0	1	1	0	0	12.5	400
0	0	1	1	0	1	27	10
0	0	1	1	1	0	27	46
0	0	1	1	1	1	27	60
0	1	0	0	0	0	10	10
0	1	0	0	0	1	10	60
0	1	0	0	1	0	60	10
0	1	0	0	1	1	27	250
0	1	0	1	0	0	27	300
0	1	0	1	0	1	27	400
0	1	0	1	1	0	30	10
0	1	0	1	1	1	30	46
0	1	1	0	0	0	30	60
0	1	1	0	0	1	30	250
0	1	1	0	1	0	30	300
0	1	1	0	1	1	30	400
0	1	1	1	0	0	46	10

FLT_Z						CUT-OFF FREQUENCY [HZ]	
0	1	1	1	0	1	46	46
0	1	1	1	1	0	46	60
0	1	1	1	1	1	46	250
1	0	0	0	0	0	60	60
1	0	0	0	0	1	10	60
1	0	0	0	1	0	60	10
1	0	0	0	1	1	46	300
1	0	0	1	0	0	46	400
1	0	0	1	0	1	60	10
1	0	0	1	1	0	60	46
1	0	0	1	1	1	60	60
1	0	1	0	0	0	60	250
1	0	1	0	0	1	60	300
1	0	1	0	1	0	60	400

Table 14. Z-axis Filter Configuration Parameters

FLT_Y						CUT-OFF FREQUENCY [HZ]	
D5	D4	D3	D2	D1	D0	GYRO_Y	ACCEL_Y
0	0	0	0	0	1	10	10
0	0	0	0	1	0	10	46
0	0	0	0	1	1	10	60
0	0	0	1	0	0	10	250
0	0	0	1	0	1	10	300
0	0	0	1	1	0	10	400
0	0	0	1	1	1	12.5	10
0	0	1	0	0	0	12.5	46
0	0	1	0	0	1	12.5	60
0	0	1	0	1	0	12.5	250
0	0	1	0	1	1	12.5	300
0	0	1	1	0	0	12.5	400
0	0	1	1	0	1	27	10
0	0	1	1	1	0	27	46
0	0	1	1	1	1	27	60
0	1	0	0	0	0	10	10
0	1	0	0	0	1	10	60
0	1	0	0	1	0	60	10
0	1	0	0	1	1	27	250
0	1	0	1	0	0	27	300
0	1	0	1	0	1	27	400
0	1	0	1	1	0	30	10

FLT_Y						CUT-OFF FREQUENCY [HZ]	
0	1	0	1	1	1	30	46
0	1	1	0	0	0	30	60
0	1	1	0	0	1	30	250
0	1	1	0	1	0	30	300
0	1	1	0	1	1	30	400
0	1	1	1	0	0	46	10
0	1	1	1	0	1	46	46
0	1	1	1	1	0	46	60
0	1	1	1	1	1	46	250
1	0	0	0	0	0	60	60
1	0	0	0	0	1	10	60
1	0	0	0	1	0	60	10
1	0	0	0	1	1	46	300
1	0	0	1	0	0	46	400
1	0	0	1	0	1	60	10
1	0	0	1	1	0	60	46
1	0	0	1	1	1	60	60
1	0	1	0	0	0	60	250
1	0	1	0	0	1	60	300
1	0	1	0	1	0	60	400

Table 15. Y-axis Filter Configuration Parameters

6.8 ACCELEROMETER AND GYROSCOPE X-AXIS FILTER SETTINGS

TYPE	BANK	OFFSET	BIT	DEFAULT	NAME	FUNCTION
RW	0	0x0E	14	0	Reserved	Reserved
RW	0	0x0E	13:8	100000	flt_x[5:0]	Output filter setting for the gyroscope's and accelerometer's x axis

This register allows to configure the filter of the x-axis accelerometer and gyroscope according to Table 15 (all settings not documented in the table are reserved).

FLT_X						CUT-OFF FREQUENCY [HZ]	
D13	D12	D11	D10	D9	D8	GYRO_X	ACCEL_X
0	0	0	0	0	1	10	10
0	0	0	0	1	0	10	46
0	0	0	0	1	1	10	60
0	0	0	1	0	0	10	250
0	0	0	1	0	1	10	300
0	0	0	1	1	0	10	400
0	0	0	1	1	1	12.5	10
0	0	1	0	0	0	12.5	46
0	0	1	0	0	1	12.5	60
0	0	1	0	1	0	12.5	250

FLT_X						CUT-OFF FREQUENCY [HZ]	
0	0	1	0	1	1	12.5	300
0	0	1	1	0	0	12.5	400
0	0	1	1	0	1	27	10
0	0	1	1	1	0	27	46
0	0	1	1	1	1	27	60
0	1	0	0	0	0	10	10
0	1	0	0	0	1	10	60
0	1	0	0	1	0	60	10
0	1	0	0	1	1	27	250
0	1	0	1	0	0	27	300
0	1	0	1	0	1	27	400
0	1	0	1	1	0	30	10
0	1	0	1	1	1	30	46
0	1	1	0	0	0	30	60
0	1	1	0	0	1	30	250
0	1	1	0	1	0	30	300
0	1	1	0	1	1	30	400
0	1	1	1	0	0	46	10
0	1	1	1	0	1	46	46
0	1	1	1	1	0	46	60
0	1	1	1	1	1	46	250
1	0	0	0	0	0	60	60
1	0	0	0	0	1	10	60
1	0	0	0	1	0	60	10
1	0	0	0	1	1	46	300
1	0	0	1	0	0	46	400
1	0	0	1	0	1	60	10
1	0	0	1	1	0	60	46
1	0	0	1	1	1	60	60
1	0	1	0	0	0	60	250
1	0	1	0	0	1	60	300
1	0	1	0	1	0	60	400

Table 16. X-axis Filter Configuration Parameters

6.9 TEMPERATURE SENSORS DIFFERENCE

TYPE	BANK	OFFSET	BIT	DEFAULT	NAME	FUNCTION
R	0	0x0F	15:0	N/A	temp12_delta[15:0]	Signed delta(T) = (temp1_data - temp2_data) in 2's complement.

This register contains the difference between temp1_data[15:0] and temp2_data[15:0] in 2's complement. The register is encoded like temp1_data[15:0] and temp2_data[15:0].

6.10 SELF-TEST REGISTER

TYPE	BANK	OFFSET	BIT	DEFAULT	NAME	FUNCTION
RW	1	0x11	11	0	en_accel_selftest	if set to 1, the bit enables the accelerometer self-test
RW	1	0x12	12	0	en_gyro_selftest	If set to 1, the bit enables the gyro self-test
RW	0	0x11, 0x12	Rest of the bits	0	Reserved	Should be left at the factory/default settings

TYPE	BANK	OFFSET	BIT	DEFAULT	NAME	FUNCTION
RW	0	0x16	10:9	00	Reserved	Should be always set to 0
RW	0	0x16	8:7	00	gyro_dc_trigger[1:0]	Activates gyroscope self-test 11: Reserved 01: self-test positive (110 dps) 10: self-test negative (-110 dps) 00: no self-test The register is not self-clearing.
RW	0	0x16	6:5	00	Reserved	Should be always set to 0
RW	0	0x16	4:3	00	accel_dc_trigger[1:0]	Activates accel self-test 11: Reserved 01: self-test positive (+3g) 10: self-test negative (-3g) 00: no self-test The register is not self-clearing.
RW	0	0x16	2:1	00	Reserved	Should be always set to 0

The self-test for accelerometer is executed with a stimulus equivalent to a variation of -3g or +3g, depending upon the setting of accel_dc_trigger. The value of en_accel_selftest should be set to 1 prior to triggering accel self test.

The self-test for Gyro is executed with a stimulus equivalent to -110dps or +110dps), depending upon the setting of gyro_dc_trigger. The value of en_gyro_selftest should be set to 1 prior to triggering gyro self test.

6.11 TEST REGISTER

TYPE	BANK	OFFSET	BIT	DEFAULT	NAME	FUNCTION
RW	0	0x17	15:0	0x0000	test[15:0]	Register available to the host controller for any purpose

This register can be used by the host controller to store temporary data for any purpose.

6.12 RESET CONTROL

TYPE	BANK	OFFSET	BIT	DEFAULT	NAME	FUNCTION
W/C	0	0x18	2	0	hard_reset	When "1" is written in hard_reset, a hardware reset is executed (power on reset, reset of register data). Putting 0V on the pin RESETN for 30 ms or more will also trigger a hardware reset.
W/C	0	0x18	1	0	soft_reset	When "1" is written in soft_reset, a software reset is executed. The software reset will: Reset addresses 0x00 to 0x07 Reset bank_select[15:0], i.e. return to bank 0 Reset all bank 0 registers except fixed_value[15:0], test[15:0], gyro_id[3:0], accel_id[4:0], hw_config[4:0], hw_rev[4:0], id_code3[15:0], id_code4[15:0].

These registers allow the user to reset the IC.

6.13 MODE REGISTERS

TYPE	BANK	OFFSET	BIT	DEFAULT	NAME	FUNCTION
RW	0	0x19	15	0	register_write_lock	"Lock of register write" bit 0: Normal 1: Register write function is locked. -When register_write_lock is set, the register write function is locked (disabled). The read function is available. When register write command is sent, the response of MISO is 11b -The release of lock status is enabled only by POR (power down) and hardware reset.
RW	0	0x19	3	0	capture_mode	Writing a 1 in capture_mode stops the refresh of the output data registers (see sections 6.1 to 6.5). Writing a 0 resumes the refresh of the output data registers.
RW	0	0x19	2:0	000	tcode_status[2:0]	Writing the sequence "010→001→100" into tcode_status[2:0] enables writing into banks other than Bank 0 and into bank_select (0x1F, available in all banks). While writing the sequence, tcode_status will be changed to 010→011→111 (e.g. when 001 is written into tcode_status, tcode_status will change to 011). If, before unlocking the banks, any other sequence is written into tcode_status, the register will actually be changed to 000. Only a power-on-reset will lock the banks again.

Please refer to section 6.17 for the process to enable writing into banks 6 and 7.

6.14 ID REGISTERS

TYPE	BANK	OFFSET	BIT	DEFAULT	NAME	FUNCTION
RW	0	0x1B	11:8	0x0	gyro_id[3:0]	Gyroscope revision
RW	0	0x1B	4:0	00000	accel_id[4:0]	Accelerometer revision
R	0	0x1C	4:0	00000	hw_rev[4:0]	Sensor revision
RW	0	0x1D	15:0	0x0000	id_code3[15:0]	Serial ID number most significant bytes
RW	0	0x1E	15:0	0x0000	id_code4[15:0]	Serial ID number least significant bytes
R	1	0x0E	7:0	0xF3	whoami[7:0]	Unique identifier for IIM-20670

This register contains the revisions of the IC, gyroscope, accelerometer, as well as serial numbers.

6.15 ODR CONFIGURATION

TYPE	BANK	OFFSET	BIT	DEFAULT	NAME	FUNCTION
RW	3	0x11	13:8	000000	ODR_Config_1	ODR clock configuration
RW	3	0x13	7:4	0000	ODR_Config_2	ODR clock configuration
RW	3	0x14	5	0	ODR_Config_3	ODR clock configuration
RW	3	0x14	9	0	ODR_Config_4	ODR clock configuration
RW	3	0x16	0	0	ODR_Config_5	ODR clock configuration
RW	3	0x17	12	0	ODR_Config_6	ODR clock configuration

6.16 BANK SELECTION

TYPE	BANK	OFFSET	BIT	DEFAULT	NAME	FUNCTION
RW	0	0x1F	15:0	0x0000	bank_select[15:0]	This register changes the selected bank. This register is normally read-only. To allow changing its contents (thereby selecting a different bank), the register tcode_status[2:0] must be written according to the procedure described in section 6.13. The register bank_select is accessible from all banks. Writing an invalid bank number will prevent from further writing into the register until the IC is reset

6.17 SENSITIVITY CONFIGURATION

TYPE	BANK	OFFSET	BIT	DEFAULT	NAME	FUNCTION
RW	6	0x14	2:0	001	accel_fs_sel[2:0]	Determines the accelerometer full scale. See Table 16 for full scale options.
RW	7	0x14	3:0	0001	gyro_fs_sel[3:0]	Determines the gyroscope full scale. See Table 17 for full scale values.

ACCEL_FS_SEL[2:0]	FS	FS _{LR}
000	16.384g	32.768g
001	16.384g	65.536g
010	32.768g	32.768g
011	32.768g	65.536g
100	2.048g	4.096g
101	2.048g	16.384g
110	4.096g	4.096g
111	4.096g	8.192g

Table 17. Accelerometer full-scale range and sensitivity

GYRO_FS_SEL[3:0]	SENSITIVITY	FS
0000	100 LSB/dps	±328dps
0001	50 LSB/dps	±655 dps
0010	25 LSB/dps	±1311 dps
0011	16.67 LSB/dps	±1966 dps
0100	150 LSB/dps	±218 dps
0101	75 LSB/dps	±437 dps
0110	37.5 LSB/dps	±874 dps
0111	25 LSB/dps	±1311 dps
1000	533.34 LSB/dps	±61 dps
1001	266.67 LSB/dps	±123 dps
1010	133.33 LSB/dps	±246 dps
1011	66.67 LSB/dps	±492 dps
1100	800 LSB/dps	±41 dps
1101	400 LSB/dps	±82 dps
1110	200 LSB/dps	±164 dps
1111	100 LSB/dps	±328 dps

Table 18. Gyroscope full-scale range and sensitivity

IIM-20670 default full-scale settings are ±655 dps for gyroscope and ±16 g for accelerometer, these settings are applied during component's factory calibration in accordance to the configuration used for product qualification.

Specification numbers reported into Table 1 and Table 2 were measured for default full-scale settings unless otherwise noted.

IIM-20670 implements a security feature to prevent unwanted full-scale change but gives to the users the flexibility to modify the default full scale following a dedicated unlock procedure.

Once the procedure above has been completed the new full-scale setting can be applied modifying the bits `accel_fs_sel[2:0]` into the register address `0x14` of bank 6, and `gyro_fs_sel[3:0]` into the register address `0x14` of bank 7.

Please note that all the other bits that are contained into the same registers have to be considered reserved and changing them might cause unwanted effects. To avoid unwanted behavior of the chip, before writing into a 16-bit register, read the whole 16-bit register first and compute the new register value by changing the desired bits only. In order to prevent unwanted changes, it is suggested to switch back to Bank0 at the end of full-scale configuration. Below procedure must be applied in order to change IIM-20670 full-scale:

1. Unlock the full-scale change operation:

- 32-bit HEX word command must be sent over SPI: `0xE4000288`
- 32-bit HEX word command must be sent over SPI: `0xE400018B`
- 32-bit HEX word command must be sent over SPI: `0xE400048E`
- 32-bit HEX word command must be sent over SPI: `0xE40300AD`
- 32-bit HEX word command must be sent over SPI: `0xE4018017`
- 32-bit HEX word command must be sent over SPI: `0xE4028030`

2. Change Accelerometer full-scale:

- Switch to Bank6: set `bank_select[15:0]` field to 6 into BANK SELECTION register (Addr=`0x1F`)
- Read accelerometer SENSITIVITY CONFIGURATION register (BANK6, Addr=`0x14`)

Compute the new register value by changing the `accel_fs_sel[2:0]` field only based on Table 17. Accelerometer full-scale range and sensitivity

- , keeping all the other bits unchanged
- Write the computed value into accelerometer SENSITIVITY CONFIGURATION register (BANK6, Addr=`0x14`)

3. Change Gyroscope full-scale:

- Switch to Bank7: set `bank_select[15:0]` field to 7 into BANK SELECTION register (Addr=`0x1F`)
- Read gyroscope SENSITIVITY CONFIGURATION register (BANK7, Addr=`0x14`)
- Compute the new register value by changing the `gyro_fs_sel[3:0]` field only based on Table 18, keeping all the other bits unchanged
- Write the computed value into gyroscope SENSITIVITY CONFIGURATION register (BANK7, Addr=`0x14`)

4. Switch to Bank0: set `bank_select[15:0]` field to 0 into BANK SELECTION register (Addr=`0x1F`)

IAM-20685 full-scale configuration must be performed as last action and must be followed by Register_write_lock bit setting to 1 (BANK0, Addr=`0x19`, bit 15). When register_write_lock bit is set, the registers write function is locked (disabled). The registers read function is only available.

7 ASSEMBLY

This section provides general guidelines for assembling TDK Micro Electro-Mechanical Systems (MEMS) gyroscopes and accelerometers packaged in DQFN package.

7.1 ORIENTATION OF AXES

The diagram below shows the orientation of the axes of sensitivity and the polarity of rotation. Note the pin 1 identifier (•) in the figure.

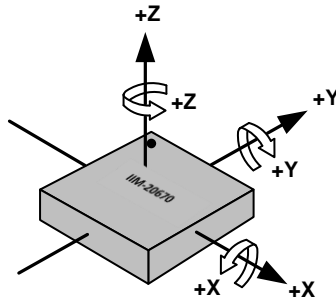

Figure 9. IIM-20670 Orientation of Axes and Polarity of Rotation

7.2 PACKAGE DIMENSIONS

The package top and side view are shown in Figure 10 and the bottom view is shown in Figure 11. The package dimensions and tolerances are shown in Table 18.

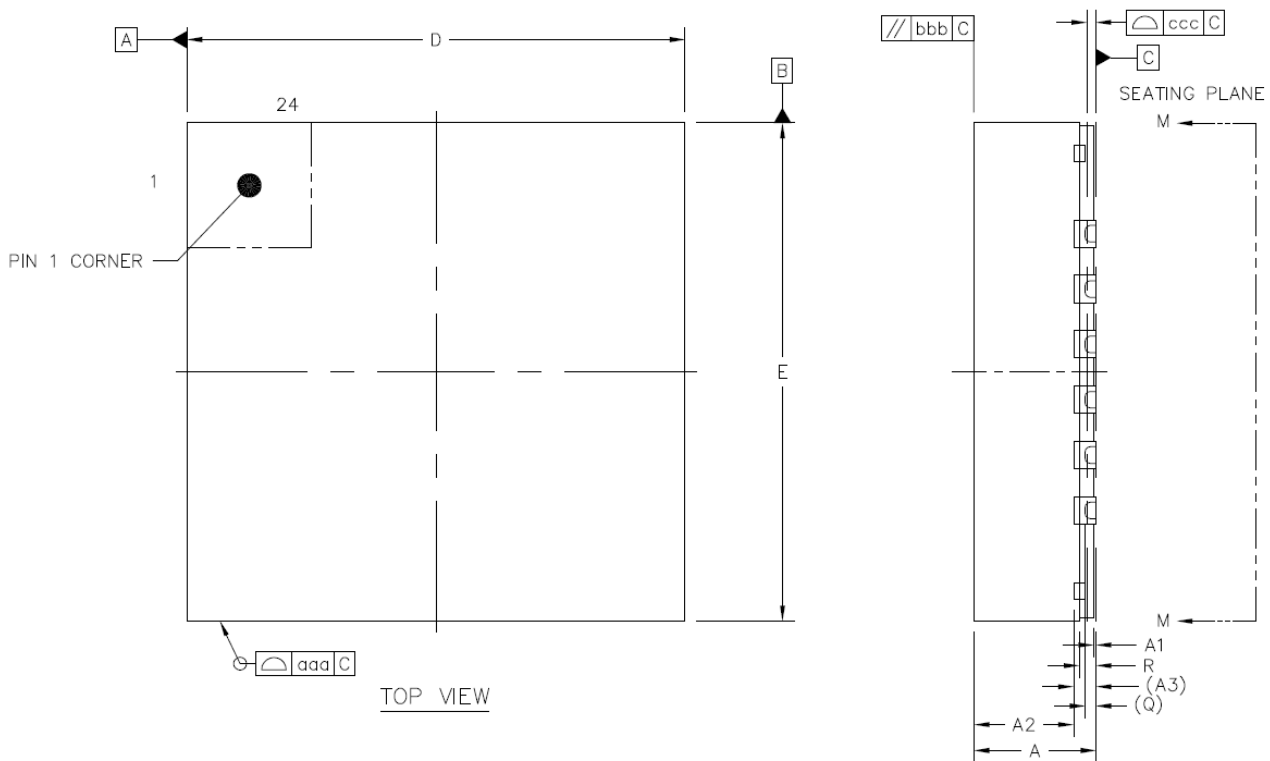

Figure 10. Package Top and Side View

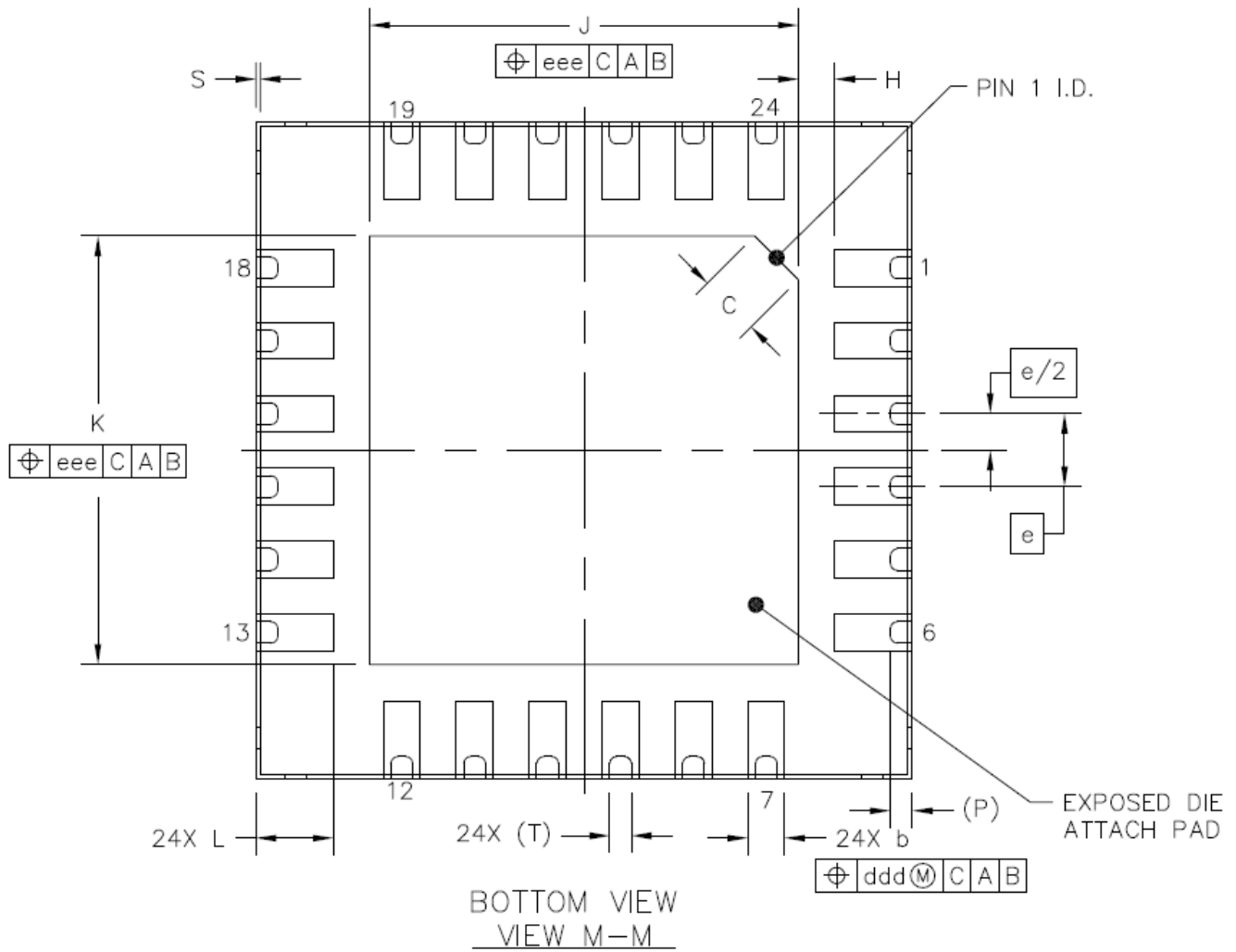

Figure 11. Package Bottom View

		SYMBOL	MIN	NOM	MAX
TOTAL THICKNESS		A	1.05	1.1	1.15
STAND OFF		A1	0	0.02	0.05
MOLD THICKNESS		A2	---	0.9	---
L/F THICKNESS		A3	0.203 REF		
LEAD WIDTH		b	0.18	0.25	0.3
BODY SIZE	X	D	4.4	4.5	4.6
	Y	E	4.4	4.5	4.6
LEAD PITCH		e	0.5 BSC		
EP SIZE	X	J	2.89	2.94	2.99
	Y	K	2.89	2.94	2.99
LEAD LENGTH		L	0.48	0.53	0.58
		C	0.374	0.424	0.474
		H	0.2	0.25	0.3
MOLD FLATNESS		bbb	0.1		
COPLANARITY		ccc	0.08		
LEAD OFFSET		ddd	0.1		
EXPOSED PAD OFFSET	eee		0.1		
	fff		0.05		
HALF-CUT DEPTH		R	0.11	0.15	0.2
HALF-CUT WIDTH		S	0.001	0.015	0.03
WETTABLE DIMPLE WIDTH		T	0.1	0.15	0.2
WETTABLE DIMPLE LENGTH		P	0.05	0.15	0.25
WETTABLE DIMPLE DEPTH		Q	0.05	0.1	0.15

Table 19. Package Dimensions

8 PART NUMBER PACKAGE MARKING

The part number package marking for IIM-20670 is summarized below:

PART NUMBER	PART NUMBER PACKAGE MARKING
IIM-20670	IIM670

Table 20. Part number package marking

In case an ES notation exists in the package marking, it denotes engineering samples. The engineering samples may have deviations with respect to the specifications and functions reported in the datasheet. Engineering samples are not production-intent parts.

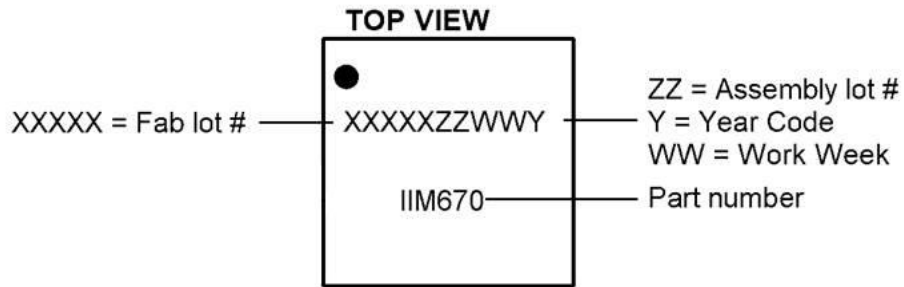

Figure 12. Part number package marking for IIM-20670

9 REFERENCE

Please refer to “InvenSense MEMS Handling Application Note (AN-IVS-0002A-00)” for the following information:

- Manufacturing Recommendations
 - Assembly Guidelines and Recommendations
 - PCB Design Guidelines and Recommendations
 - MEMS Handling Instructions
 - ESD Considerations
 - Reflow Specification
 - Storage Specifications
 - Package Marking Specification
 - Tape & Reel Specification
 - Reel & Pizza Box Label
 - Packaging
 - Representative Shipping Carton Label
- Compliance
 - Environmental Compliance
 - DRC Compliance
 - Compliance Declaration Disclaimer

10 DOCUMENT INFORMATION

10.1 REVISION HISTORY

REVISION DATE	REVISION	DESCRIPTION
05/05/2023	1.0	Initial release

This information furnished by InvenSense, Inc. (“InvenSense”) is believed to be accurate and reliable. However, no responsibility is assumed by InvenSense for its use, or for any infringements of patents or other rights of third parties that may result from its use. Specifications are subject to change without notice. InvenSense reserves the right to make changes to this product, including its circuits and software, in order to improve its design and/or performance, without prior notice. InvenSense makes no warranties, neither expressed nor implied, regarding the information and specifications contained in this document. InvenSense assumes no responsibility for any claims or damages arising from information contained in this document, or from the use of products and services detailed therein. This includes, but is not limited to, claims or damages based on the infringement of patents, copyrights, mask work and/or other intellectual property rights.

Certain intellectual property owned by InvenSense and described in this document is patent protected. No license is granted by implication or otherwise under any patent or patent rights of InvenSense. This publication supersedes and replaces all information previously supplied. Trademarks that are registered trademarks are the property of their respective companies. InvenSense sensors should not be used or sold in the development, storage, production or utilization of any conventional or mass-destructive weapons or for any other weapons or life threatening applications, as well as in any other life critical applications such as medical equipment, transportation, aerospace and nuclear instruments, undersea equipment, power plant equipment, disaster prevention and crime prevention equipment.

©2023 InvenSense. All rights reserved. InvenSense, MotionTracking, MotionProcessing, MotionProcessor, MotionFusion, MotionApps, DMP, AAR, and the InvenSense logo are trademarks of InvenSense, Inc. The TDK logo is a trademark of TDK Corporation. Other company and product names may be trademarks of the respective companies with which they are associated.



©2023 InvenSense. All rights reserved.