

#### PROTECTION PRODUCTS - RailClamp®

#### Description

RailClamp® is a low capacitance TVS array designed to protect high speed data interfaces. This series has been specifically designed to protect sensitive components which are connected to data and transmission lines from overvoltage caused by **ESD** (electrostatic discharge), **CDE** (Cable Discharge Events), and **EFT** (electrical fast transients).

The monolithic design incorporates surge rated, low capacitance steering diodes and a TVS diode in a single package. Each line has a maximum capacitance of < 0.8pF to ground. The capacitance of each line is well matched for constant signal balance. This device is optimized for ESD protection of portable electronics. It may be used to meet the ESD immunity requirements of IEC 61000-4-2, Level 4 ( $\pm 15\text{kV}$  air,  $\pm 8\text{kV}$  contact discharge).

The RClamp™2504P and RClamp™3304P are constructed using Semtech's proprietary EPD process technology. The EPD process provides low standoff voltages with significant reductions in leakage current and capacitance over silicon-avalanche diode processes. They feature a true operating voltage of 2.5 volts and 3.3 volts for superior protection.

These devices are in a 6-pin, RoHS/WEEE compliant, SLP1616P6 package measuring 1.6 x 1.6 x 0.58mm. The leads are spaced at a pitch of 0.5mm and are finished with lead-free NiPdAu.

#### Features

- ◆ Transient protection for high-speed data lines to **IEC 61000-4-2 (ESD)  $\pm 15\text{kV}$  (air),  $\pm 8\text{kV}$  (contact)**  
**IEC 61000-4-4 (EFT) 40A (5/50ns)**
- ◆ Array of surge rated diodes with internal TVS Diode
- ◆ Small package saves board space
- ◆ Protects up to four I/O lines
- ◆ Low capacitance (**<0.8pF**) for high-speed interfaces
- ◆ Minimal insertion loss to **3.0GHz**
- ◆ Low operating voltage: **2.5V and 3.3V**
- ◆ Low leakage current and clamping voltage
- ◆ Solid-state silicon-avalanche technology

#### Mechanical Characteristics

- ◆ SLP1616P6 package
- ◆ RoHS/WEEE Compliant
- ◆ Nominal Dimensions: 1.6 x 1.6 x 0.58 mm
- ◆ Lead Finish: NiPdAu
- ◆ Molding compound flammability rating: UL 94V-0
- ◆ Marking: Marking Code + Date Code
- ◆ Packaging: Tape and Reel per EIA 481

#### Applications

- ◆ Multi Media Card (MMC) Interfaces
- ◆ SATA Interfaces
- ◆ SD Card Interfaces
- ◆ SIM Ports
- ◆ MDDI Ports
- ◆ MPPI Ports

#### Circuit Diagram

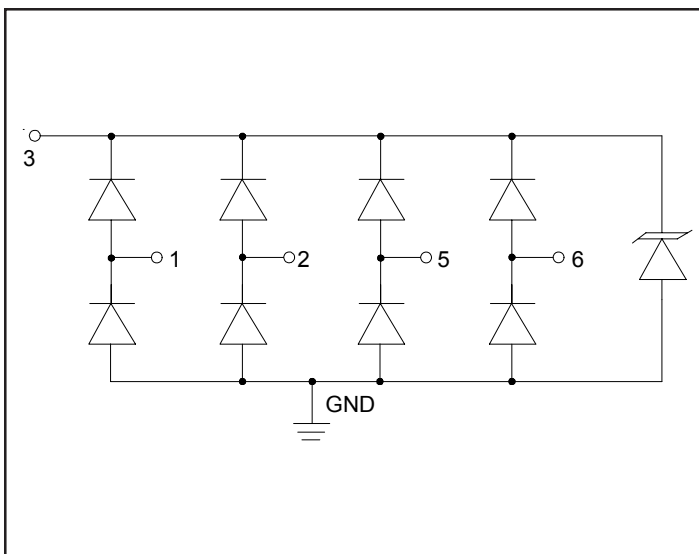

#### Pin Configuration

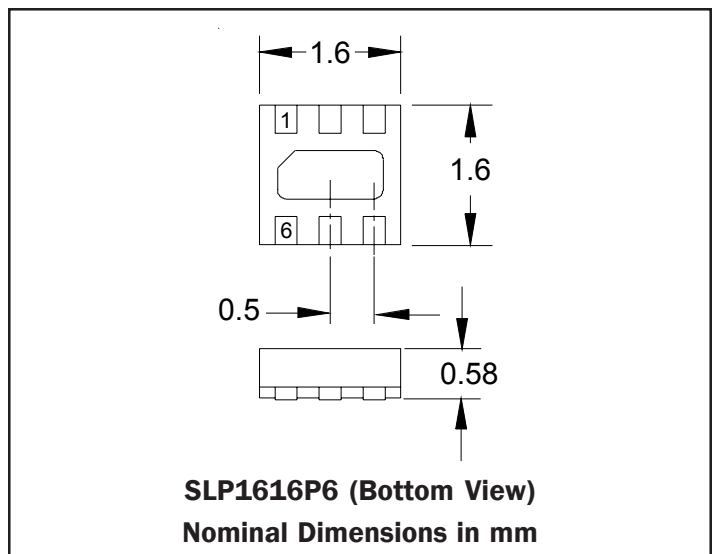

## PROTECTION PRODUCTS

### Absolute Maximum Rating

Rating	Symbol	Value	Units
Peak Pulse Power (tp = 8/20μs)	$P_{pk}$	80	Watts
Peak Pulse Current (tp = 8/20μs)	$I_{PP}$	5	A
ESD per IEC 61000-4-2 (Air) ESD per IEC 61000-4-2 (Contact)	$V_{ESD}$	20 12	kV
Operating Temperature	$T_J$	-40 to +85	°C
Storage Temperature	$T_{STG}$	-55 to +150	°C

### Electrical Characteristics (T=25°C)

RClamp2504P						
Parameter	Symbol	Conditions	Minimum	Typical	Maximum	Units
Reverse Stand-Off Voltage	$V_{RWM}$	Pin 3 to GND			2.5	V
Punch-Through Voltage	$V_{PT}$	$I_{PT} = 2\mu A$	2.7			V
Snap-Back Voltage	$V_{SB}$	$I_{SB} = 50mA$	2.0			V
Reverse Leakage Current	$I_R$	$V_{RWM} = 2.5V, T=25^\circ C$			0.5	μA
Clamping Voltage	$V_C$	$I_{PP} = 1A, t_p = 8/20\mu s$			6.5	V
Clamping Voltage	$V_C$	$I_{PP} = 5A, t_p = 8/20\mu s$			13	V
Junction Capacitance	$C_j$	VR = 0V, f = 1MHz Any I/O pin to GND			0.8	pF
		VR = 0V, f = 1MHz Between I/O pins		0.4		pF

## PROTECTION PRODUCTS

RClamp3304P						
Parameter	Symbol	Conditions	Minimum	Typical	Maximum	Units
Reverse Stand-Off Voltage	$V_{RWM}$	Pin 3 to GND			3.3	V
Punch-Through Voltage	$V_{PT}$	$I_{PT} = 2\mu A$	3.5			V
Snap-Back Voltage	$V_{SB}$	$I_{SB} = 50mA$	2.8			V
Reverse Leakage Current	$I_R$	$V_{RWM} = 3.3V, T=25^\circ C$			0.5	$\mu A$
Clamping Voltage	$V_C$	$I_{PP} = 1A, t_p = 8/20\mu s$ Any I/O GND			7.5	V
Clamping Voltage	$V_C$	$I_{PP} = 5A, t_p = 8/20\mu s$ Any I/O to GND			16	V
Junction Capacitance	$C_j$	$V_R = 0V, f = 1MHz$ Any I/O pin to GND			0.8	pF
		$V_R = 0V, f = 1MHz$ Between I/O pins		0.4		pF

## PROTECTION PRODUCTS

### Typical Characteristics

#### Non-Repetitive Peak Pulse Power vs. Pulse Time

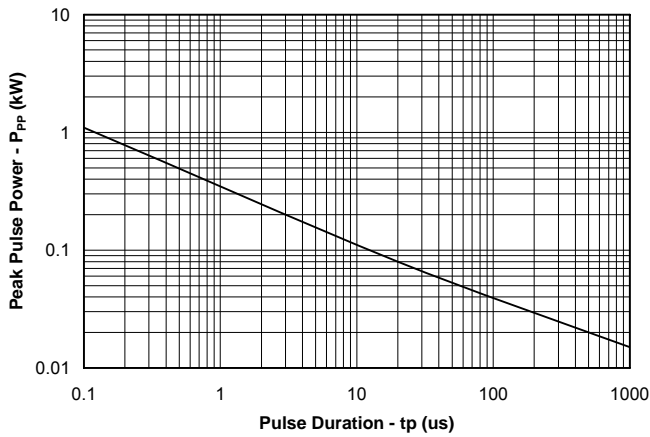

#### Power Derating Curve

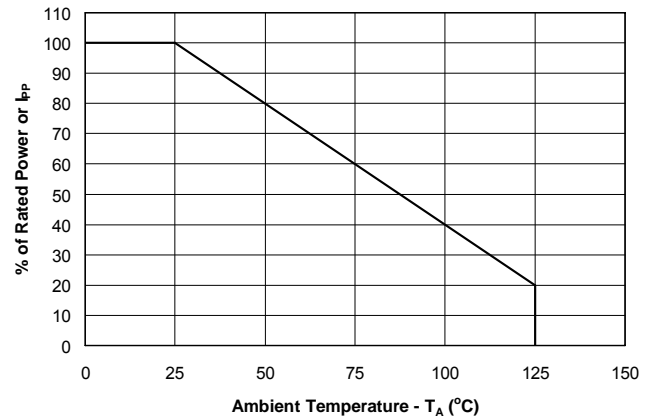

#### Pulse Waveform

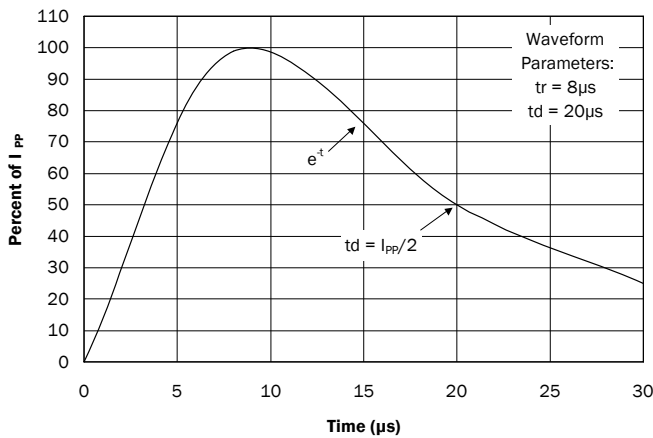

#### Junction Capacitance vs. Reverse Voltage

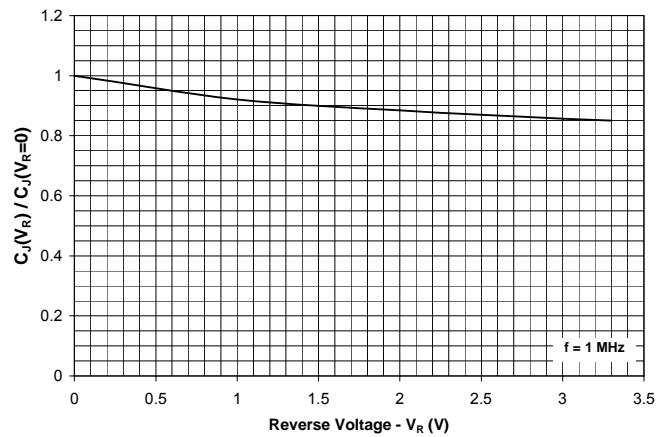

#### Clamping Voltage vs. Peak Pulse Current I/O to GND

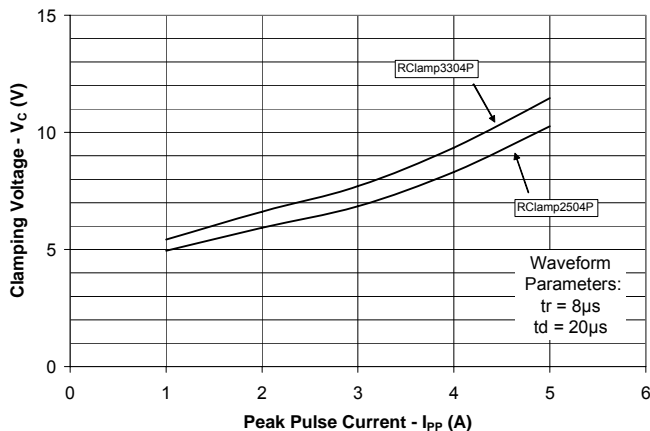

#### Clamping Voltage vs. Peak Pulse Current I/O to I/O

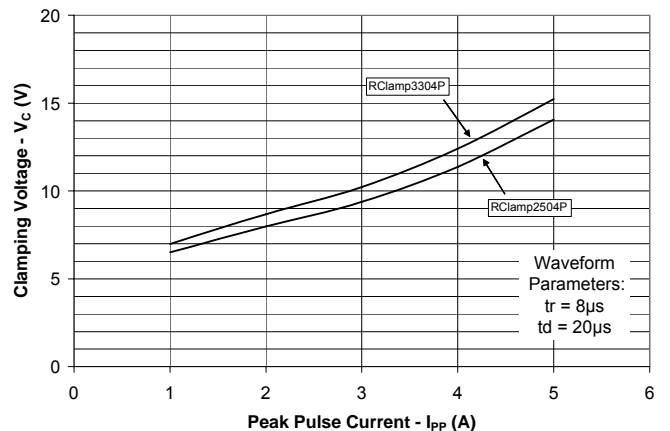

## PROTECTION PRODUCTS

### Typical Characteristics

**Insertion Loss S21 (I/O to Gnd)**

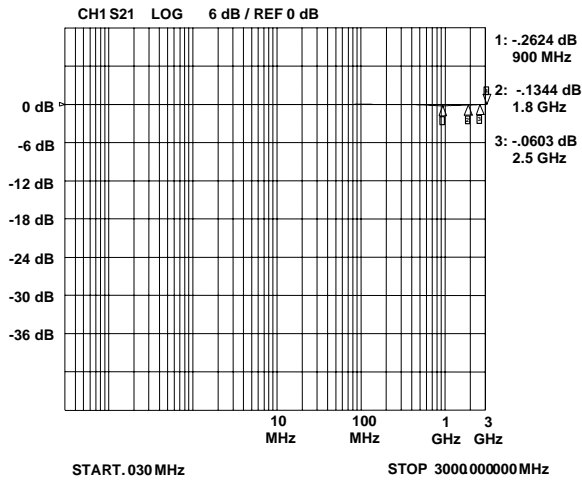

**Analog Crosstalk**

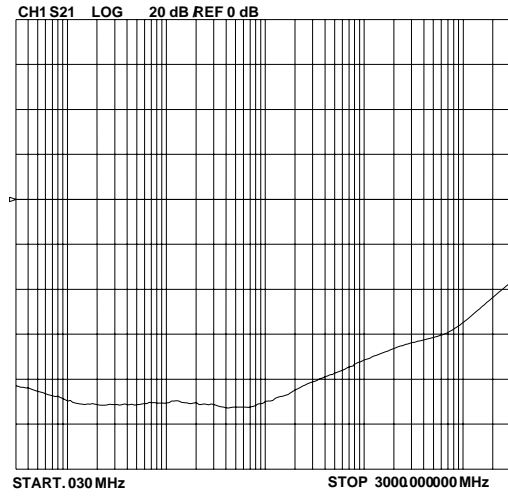

**ESD Response (8kV Contact per IEC 61000-4-2)**

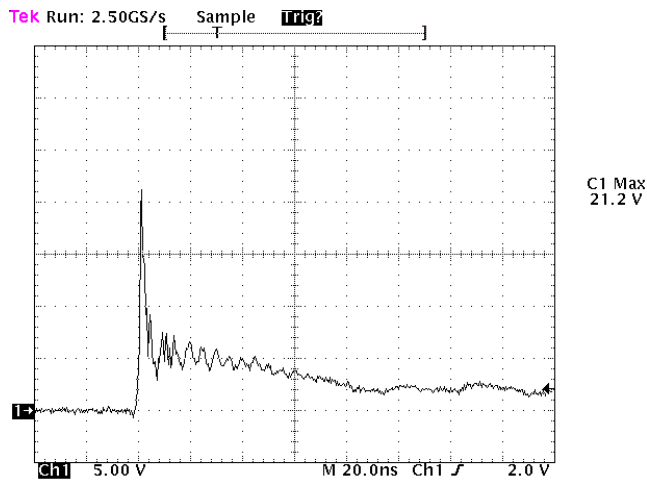

## PROTECTION PRODUCTS

### Applications Information

#### Device Connection for Protection of Four High-Speed Data Lines

These devices are designed to protect low voltage data lines operating at 2.5 volts or 3.3 volts. When the voltage on the protected line exceeds the TVS working voltage, the steering diodes are forward biased, conducting the transient current away from the sensitive circuitry, through the internal TVS to ground. Data lines are connected at pins 1, 2, 5 and 6. The center pin should be connected directly to a ground plane. The path length is kept as short as possible to minimize parasitic inductance. For best results, multiple micro-vias connected to ground are recommended. Pins 3 and 4 are not connected.

Note that pin 3 is connected internally to the cathode of the low voltage TVS. However, due to the snap-back characteristics of the EPD TVS, this pin should not be directly connected to a DC supply voltage.

Figure 1. Pin Configuration (Top Side View)

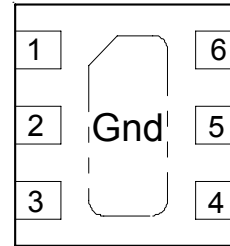

Pin	Identification
1, 2, 5, 6	Input/Output Lines
4	Not Connected
3	2.5V or 3.3V (Do not connect this pin to a DC supply)
Center Tab	Ground

#### Protection of Four Data Lines

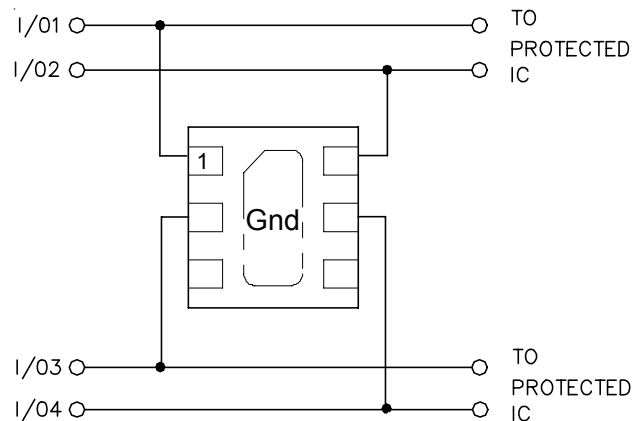

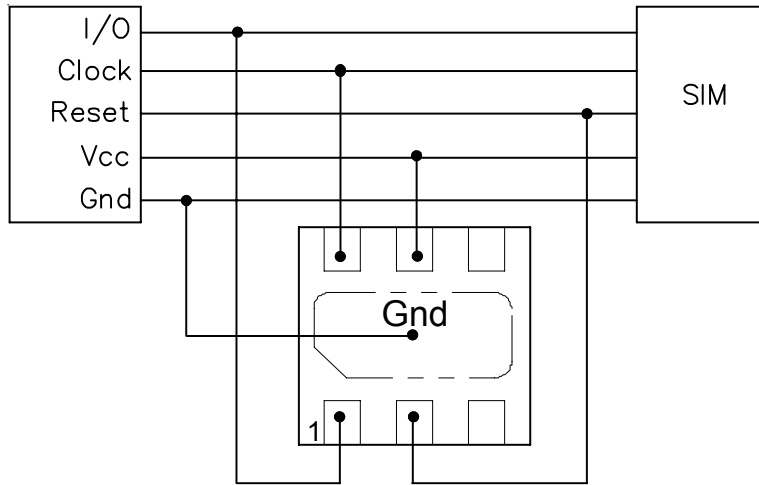
**PROTECTION PRODUCTS****Typical Applications****SIM Port - Protection of Three Data Lines and VCC**

## PROTECTION PRODUCTS

### Applications Information - Spice Model

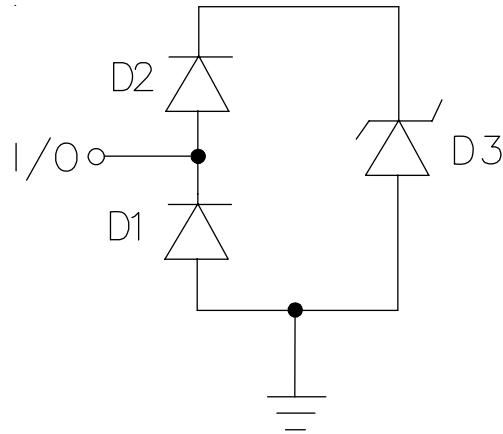

**RClamp2504P Spice Model**

RClamp2504P Spice Parameters				
Parameter	Unit	D1 (LCRD)	D2 (LCRD)	D3 (TVS)
IS	Amp	1E-20	1E-20	2.19E-12
BV	Volt	100	100	2.88
VJ	Volt	0.7	0.7	0.6
RS	Ohm	0.456	0.714	0.195
IBV	Amp	1E-3	1E-3	1E-3
CJO	Farad	0.3E-12	0.3E-12	63E-12
TT	sec	2.541E-9	2.541E-9	2.541E-9
M	--	0.01	0.01	0.16
N	--	1.1	1.1	1.1
EG	eV	1.11	1.11	1.11

## PROTECTION PRODUCTS

### Applications Information - Spice Model

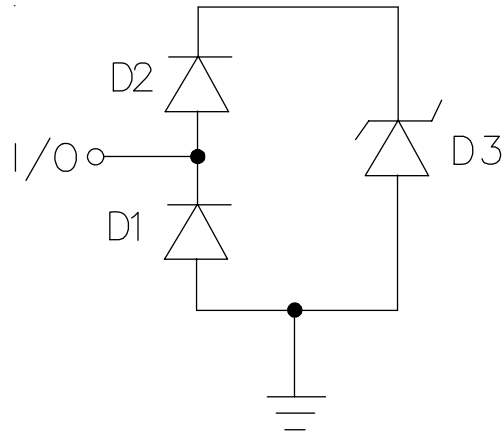

**RClamp3304P Spice Model**

RClamp3304P Spice Parameters				
Parameter	Unit	D1 (LCRD)	D2 (LCRD)	D3 (TVS)
IS	Amp	1E-20	1E-20	2.19E-12
BV	Volt	100	100	3.3
VJ	Volt	0.70	0.70	0.62
RS	Ohm	0.456	0.714	0.36
IBV	Amp	1E-3	1E-3	1E-3
CJO	Farad	0.3E-12	0.3E-12	73E-12
TT	sec	2.541E-9	2.541E-9	2.541E-9
M	--	0.01	0.01	0.18
N	--	1.1	1.1	1.1
EG	eV	1.11	1.11	1.11

## PROTECTION PRODUCTS

### Outline Drawing - SLP1616P6

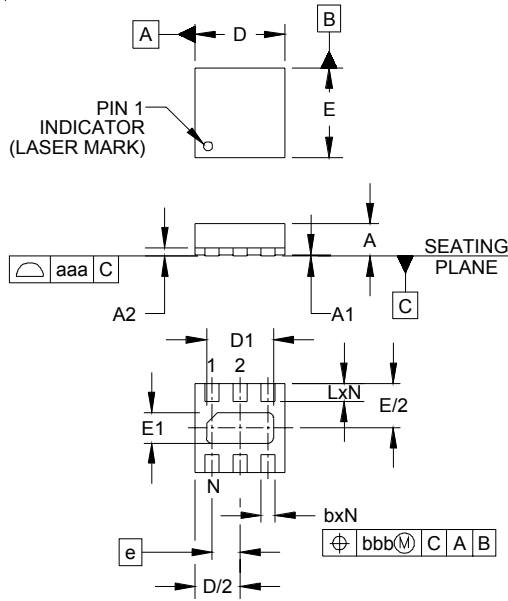

DIM	INCHES			MILLIMETERS		
	MIN	NOM	MAX	MIN	NOM	MAX
A	.020	.023	.026	0.50	0.58	0.65
A1	0.00	.001	.002	0.00	0.03	0.05
A2		(.006)			(0.15)	
b	.007	.010	.012	0.20	0.25	0.30
D	.059	.063	.067	1.50	1.60	1.70
D1	.041	.047	.051	1.05	1.20	1.30
E	.059	.063	.067	1.50	1.60	1.70
E1	.016	.022	.026	0.40	0.55	0.65
e		.020 BSC			0.50 BSC	
L	.013	.013	.016	0.25	0.33	0.40
N		6			6	
aaa		.004			0.09	
bbb		.004			0.09	

**NOTES:**

1. CONTROLLING DIMENSIONS ARE IN MILLIMETERS (ANGLES IN DEGREES).
2. COPLANARITY APPLIES TO THE EXPOSED PAD AS WELL AS THE TERMINALS.

### Land Pattern - SLP1616P6

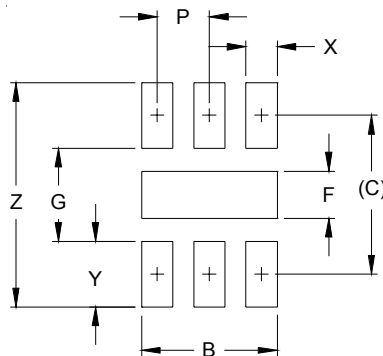

DIM	DIMENSIONS	
	INCHES	MILLIMETERS
B	.051	1.30
C	.060	1.52
P	.020	0.50
F	.018	0.45
G	.035	0.89
X	.012	0.30
Y	.025	0.63
Z	.085	2.15

**NOTES:**

1. THIS LAND PATTERN IS FOR REFERENCE PURPOSES ONLY. CONSULT YOUR MANUFACTURING GROUP TO ENSURE YOUR COMPANY'S MANUFACTURING GUIDELINES ARE MET

## PROTECTION PRODUCTS

### Marking

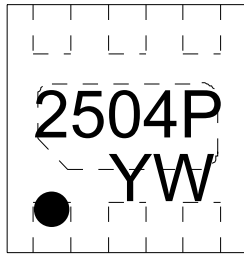

RClamp2504P

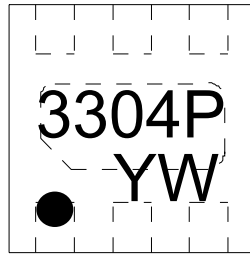

RClamp3304P

YW = Date Code

### Ordering Information

Part Number	Working Voltage	Qty per Reel	Reel Size
RClamp2504P.TCT	2.5 Volts	3,000	7 Inch
RClamp3304P.TCT	3.3 Volts	3,000	7 Inch

RailClamp and RClamp are marks of Semtech Corporation

### Tape and Reel Specification

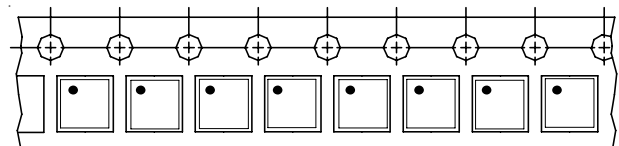
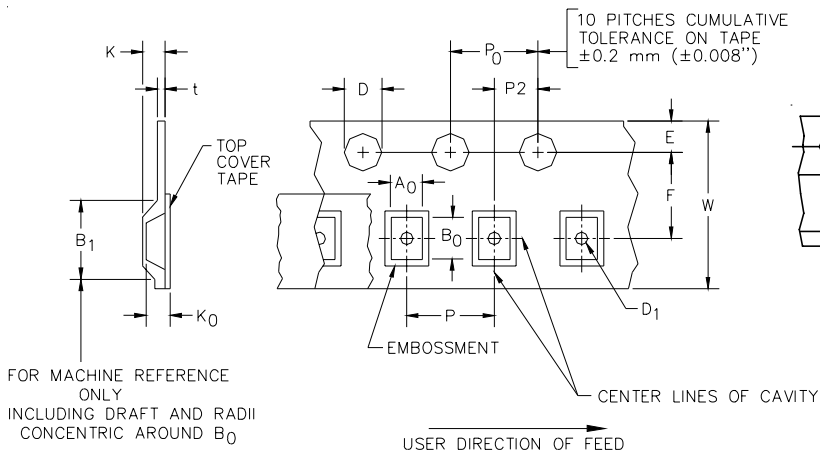

**Device Orientation in Tape  
(Pin 1 upper left towards sprocket holes)**

A0	B0	K0
1.78 +/-0.05 mm	1.78 +/-0.05 mm	0.69 +/-0.05 mm

Tape Width	B, (Max)	D	D1	E	F	K (MAX)	P	P0	P2	T(MAX)	W
8 mm	4.2 mm	1.5 + 0.1 mm - 0.0 mm )	0.5 mm ±0.05	1.750±.10 mm	3.5±0.05 mm	2.4 mm	4.0±0.1 mm	4.0±0.1 mm	2.0±0.05 mm	0.4 mm	8.0 mm + 0.3 mm - 0.1 mm

### Contact Information

Semtech Corporation  
 Protection Products Division  
 200 Flynn Rd., Camarillo, CA 93012  
 Phone: (805)498-2111 FAX (805)498-3804