

Voltage Detector (Reset) IC Series

# Free Time Delay Setting CMOS Voltage Detector (Reset) IC

## BD52xxG-1 Series

### General Description

ROHM's Free Time Delay Setting CMOS Voltage Detector ICs are highly accurate, with ultra-low current consumption feature that uses CMOS process. Delay time setting can be control by an external capacitor. The lineup includes N-channel open drain output (BD52xxG-1). The devices are available for specific detection voltage ranging from 0.9 V to 5.0 V with 0.1 V increment. The time delay has  $\pm 30\%$  accuracy in the overall operating temperature range of  $-40\text{ }^{\circ}\text{C}$  to  $85\text{ }^{\circ}\text{C}$ .

### Features

- Nano Energy™
- Delay Time Setting Controlled by External Capacitor
- Nch Open Drain Output Type
- Very Small, Lightweight and Thin Package
- Package SSOP5 is similar to SOT-23-5 (JEDEC)

### Key Specifications

- Detection Voltage Accuracy:
  - $\pm 1.0\%$   $\pm 5\text{ mV}$  ( $V_{\text{DET}} = 0.9\text{ V}$  to  $1.6\text{ V}$ )
  - $\pm 0.9\%$  ( $V_{\text{DET}} = 1.7\text{ V}$  to  $5.0\text{ V}$ )
- Detection Voltage:  $0.9\text{ V}$  to  $5.0\text{ V}$  (Typ)  
0.1 V step
- Ultra-Low Current Consumption:  $270\text{ nA}$  (Typ)
- Time Delay Accuracy:  $\pm 30\%$  ( $-40\text{ }^{\circ}\text{C}$  to  $+85\text{ }^{\circ}\text{C}$ ,  
CT pin capacitor  $\geq 1\text{ nF}$ )

### Package

SSOP5:

W(Typ) x D(Typ) x H(Max)  
 $2.90\text{ mm} \times 2.80\text{ mm} \times 1.25\text{ mm}$



### Application

All consumer devices that requires voltage detection

### Typical Application Circuit

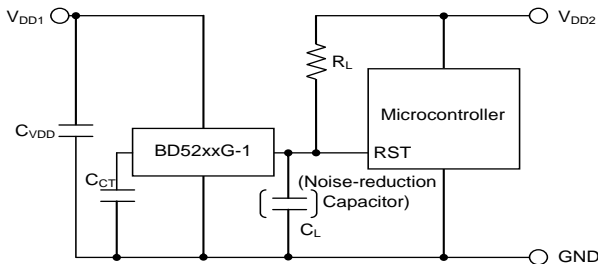
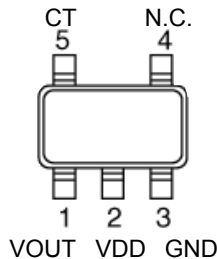

Figure 1. Open Drain Output Type  
BD52xxG-1 Series

### Pin Configuration

SSOP5  
TOP VIEW



### Pin Description

SSOP5		
PIN No.	PIN Name	Function
1	VOUT	Output pin
2	VDD	Power supply voltage
3	GND	GND
4	N.C.	No connection pin
5	CT	Capacitor connection pin for output delay time setting

N.C. pin is electrically open and can be connected to either VDD or GND.

Nano Energy™ is a trademark or a registered trademark of ROHM Co., Ltd.

○Product structure : Silicon integrated circuit ○This product has no designed protection against radioactive rays

Block Diagram

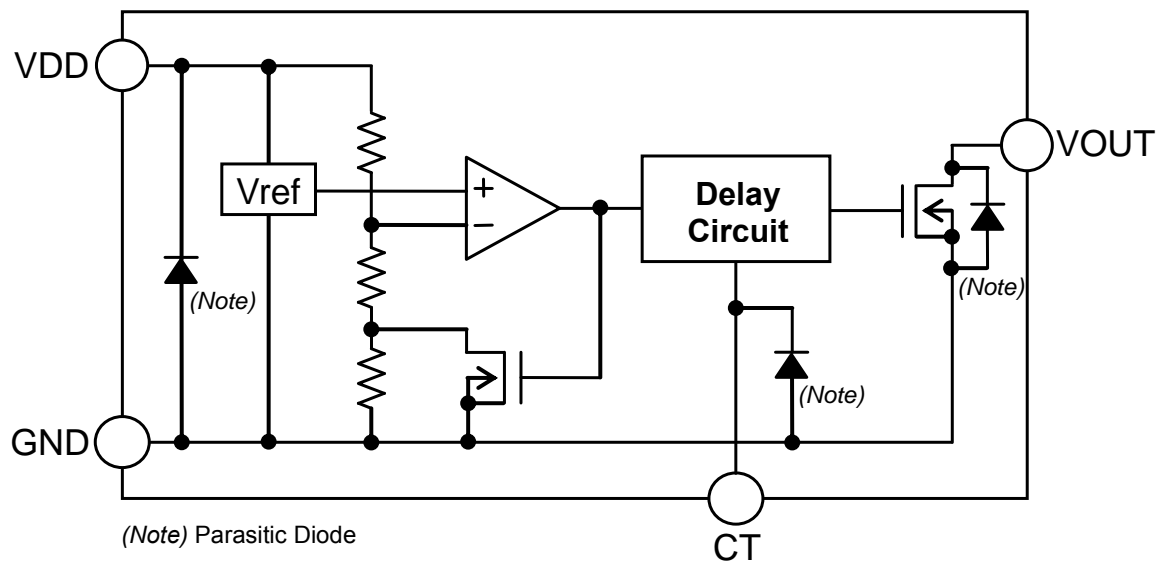
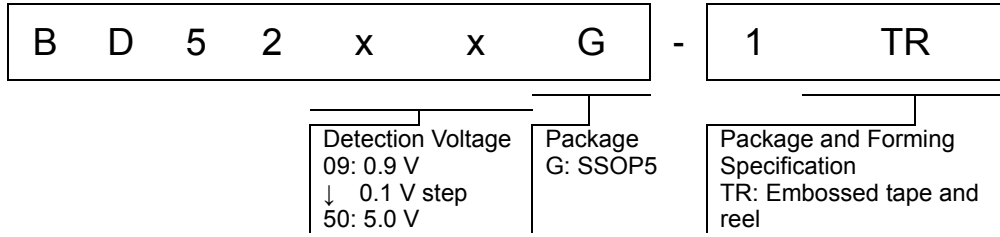

Figure 2. BD52xxG-1 Series

Ordering Information



Lineup

Output Type	Open Drain Output	
Detection Voltage	Part Number Marking	Orderable Part Number
5.0 V	fZ	BD5250G-1TR
4.9 V	fY	BD5249G-1TR
4.8 V	fX	BD5248G-1TR
4.7 V	fW	BD5247G-1TR
4.6 V	fV	BD5246G-1TR
4.5 V	fU	BD5245G-1TR
4.4 V	fT	BD5244G-1TR
4.3 V	fS	BD5243G-1TR
4.2 V	fR	BD5242G-1TR
4.1 V	fQ	BD5241G-1TR
4.0 V	fP	BD5240G-1TR
3.9 V	fN	BD5239G-1TR
3.8 V	fM	BD5238G-1TR
3.7 V	fL	BD5237G-1TR
3.6 V	fK	BD5236G-1TR
3.5 V	fJ	BD5235G-1TR
3.4 V	fH	BD5234G-1TR
3.3 V	fG	BD5233G-1TR
3.2 V	fF	BD5232G-1TR
3.1 V	fE	BD5231G-1TR
3.0 V	fD	BD5230G-1TR
2.9 V	fC	BD5229G-1TR
2.8 V	fB	BD5228G-1TR
2.7 V	hZ	BD5227G-1TR
2.6 V	hY	BD5226G-1TR
2.5 V	hX	BD5225G-1TR
2.4 V	hW	BD5224G-1TR
2.3 V	hV	BD5223G-1TR
2.2 V	hU	BD5222G-1TR
2.1 V	hT	BD5221G-1TR
2.0 V	hS	BD5220G-1TR
1.9 V	hR	BD5219G-1TR
1.8 V	hQ	BD5218G-1TR
1.7 V	hP	BD5217G-1TR
1.6 V	hN	BD5216G-1TR
1.5 V	hM	BD5215G-1TR
1.4 V	hL	BD5214G-1TR
1.3 V	hK	BD5213G-1TR
1.2 V	hJ	BD5212G-1TR
1.1 V	hH	BD5211G-1TR
1.0 V	hG	BD5210G-1TR
0.9 V	hF	BD5209G-1TR

Marking Diagram

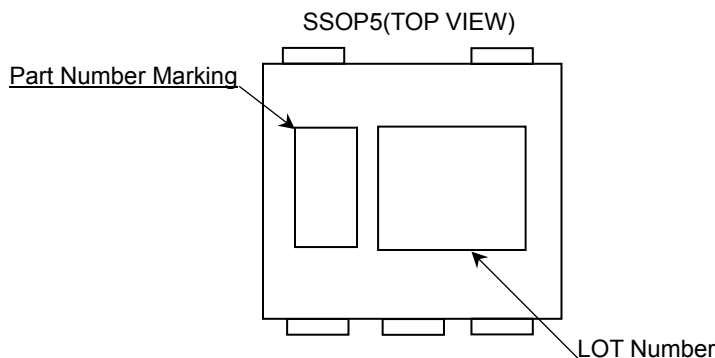

**Absolute Maximum Ratings (Ta = 25 °C)**

Parameter	Symbol	Limit	Unit
Power Supply Voltage	V <sub>DD</sub> - GND	-0.3 to +7	V
Output Voltage	Nch Open Drain Output V <sub>OUT</sub>	GND-0.3 to +7	V
Output Current	I <sub>o</sub>	70	mA
Maximum Junction Temperature	T <sub>jmax</sub>	+150	°C
Storage Temperature Range	T <sub>stg</sub>	-55 to +150	°C

**Caution 1:** Operating the IC over the absolute maximum ratings may damage the IC. The damage can either be a short circuit between pins or an open circuit between pins and the internal circuitry. Therefore, it is important to consider circuit protection measures, such as adding a fuse, in case the IC is operated over the absolute maximum ratings.

**Caution 2:** Should by any chance the maximum junction temperature rating be exceeded the rise in temperature of the chip may result in deterioration of the properties of the chip. In case of exceeding this absolute maximum rating, design a PCB with thermal resistance taken into consideration by increasing board size and copper area so as not to exceed the maximum junction temperature rating.

**Thermal Resistance<sup>(Note 1)</sup>**

Parameter	Symbol	Thermal Resistance (Typ)		Unit
		1s <sup>(Note 3)</sup>	2s2p <sup>(Note 4)</sup>	
SSOP5				
Junction to Ambient	θ <sub>JA</sub>	376.5	185.4	°C/W
Junction to Top Characterization Parameter <sup>(Note 2)</sup>	Ψ <sub>JT</sub>	40	30	°C/W

(Note 1) Based on JESD51-2A(Still-Air).

(Note 2) The thermal characterization parameter to report the difference between junction temperature and the temperature at the top center of the outside surface of the component package.

(Note 3) Using a PCB board based on JESD51-3.

(Note 4) Using a PCB board based on JESD51-7.

Layer Number of Measurement Board	Material	Board Size
Single	FR-4	114.3 mm x 76.2 mm x 1.57 mmt

Top	
Copper Pattern	Thickness
Footprints and Traces	70 μm

Layer Number of Measurement Board	Material	Board Size
4 Layers	FR-4	114.3 mm x 76.2 mm x 1.6 mmt

Top		2 Internal Layers		Bottom	
Copper Pattern	Thickness	Copper Pattern	Thickness	Copper Pattern	Thickness
Footprints and Traces	70 μm	74.2 mm x 74.2 mm	35 μm	74.2 mm x 74.2 mm	70 μm

**Recommended Operating Conditions**

Parameter	Symbol	Min	Typ	Max	Unit
Operating Temperature	T <sub>opr</sub>	-40	+25	+85	°C

Electrical Characteristics (Unless otherwise specified Ta = +25 °C, V<sub>DD</sub> = 0.8 V to 6.0 V)

Parameter	Symbol	Condition	Limit			Unit
			Min	Typ	Max	
Detection Voltage	V <sub>DET</sub>	V <sub>DET</sub> = 0.9 V to 1.6 V, V <sub>DD</sub> = H→L, R <sub>L</sub> = 100 kΩ (Note 2)	V <sub>DET</sub> (T) × 0.99 - 0.005	V <sub>DET</sub> (T) (Note 1)	V <sub>DET</sub> (T) × 1.01 + 0.005	V
		V <sub>DET</sub> = 1.7 V to 5.0 V, V <sub>DD</sub> = H→L, R <sub>L</sub> = 100 kΩ (Note 2)	V <sub>DET</sub> (T) × 0.991	V <sub>DET</sub> (T) (Note 1)	V <sub>DET</sub> (T) × 1.009	
Hysteresis Voltage	ΔV <sub>DET</sub>	V <sub>DD</sub> = L→H→L, R <sub>L</sub> = 100 kΩ (Note 2)	V <sub>DET</sub> × 0.03	V <sub>DET</sub> × 0.05	V <sub>DET</sub> × 0.07	V
Circuit Current when ON	I <sub>DD1</sub>	V <sub>DD</sub> = V <sub>DET</sub> - 0.2 V	-	230	800	nA
Circuit Current when OFF	I <sub>DD2</sub>	V <sub>DD</sub> = V <sub>DET</sub> + 0.5 V	-	270	900	nA
Minimum Operating Voltage	V <sub>OPL</sub>	V <sub>OL</sub> ≤ 0.4 V, R <sub>L</sub> = 100 kΩ (Note 2)	0.80	-	-	V
"Low" Output Voltage (Nch)	V <sub>OL</sub>	V <sub>DD</sub> = 0.8 V, I <sub>SINK</sub> = 0.17 mA, V <sub>DET</sub> = 0.9 V to 1.6 V	-	-	0.4	V
		V <sub>DD</sub> = 1.2 V, I <sub>SINK</sub> = 1.0 mA, V <sub>DET</sub> = 1.7 V to 5.0 V	-	-	0.4	
		V <sub>DD</sub> = 2.4 V, I <sub>SINK</sub> = 2.0 mA, V <sub>DET</sub> = 2.7 V to 5.0 V	-	-	0.4	
Output Leak Current	I <sub>leak</sub>	V <sub>DD</sub> = V <sub>DS</sub> = 6 V	-	-	0.1	μA
Delay Time (L→H)	t <sub>PLH</sub>	V <sub>OUT</sub> = GND→50 %, C <sub>CT</sub> = 0.01 μF, Ta = -40 °C to +85 °C (Note 3) (Note 4) (Note 5)	38.9	55.5	72.1	ms

(Note 1) V<sub>DET</sub>(T): Standard Detection Voltage (0.9 V to 5.0 V, 0.1 V step)

(Note 2) R<sub>L</sub>: Pull-up resistor connected between V<sub>OUT</sub> and power supply

(Note 3) t<sub>PLH</sub>: V<sub>DD</sub> = (V<sub>DET</sub>(T) - 0.1 V) → (V<sub>DET</sub>(T) + 0.5 V) for V<sub>DET</sub> = 0.9 V to 1.2 V

t<sub>PLH</sub>: V<sub>DD</sub> = (V<sub>DET</sub>(T) - 0.5 V) → (V<sub>DET</sub>(T) + 0.5 V) for V<sub>DET</sub> = 1.3 V to 5.0 V

(Note 4) C<sub>T</sub> delay capacitor range: open to 4.7 μF

(Note 5) Not 100 % tested.

## Function Explanation

## 1. Nano Energy™

Nano Energy™ is a combination of technologies which realizes ultra low quiescent current operation.

## Detection Voltage Summary

Product Name	Detection Voltage [V] (Ta = +25 °C)		Detection Voltage [V] <sup>(Note 1)</sup> (Ta = -40 °C to +85 °C)	
	Min	Max	Min	Max
Open Drain Output				
BD5209G-1TR	0.886	0.914	0.870	0.930
BD5210G-1TR	0.985	1.015	0.967	1.033
BD5211G-1TR	1.084	1.116	1.064	1.136
BD5212G-1TR	1.183	1.217	1.162	1.238
BD5213G-1TR	1.282	1.318	1.259	1.341
BD5214G-1TR	1.381	1.419	1.356	1.444
BD5215G-1TR	1.480	1.520	1.453	1.547
BD5216G-1TR	1.579	1.621	1.551	1.649
BD5217G-1TR	1.684	1.716	1.666	1.734
BD5218G-1TR	1.783	1.817	1.764	1.836
BD5219G-1TR	1.882	1.918	1.862	1.938
BD5220G-1TR	1.982	2.018	1.960	2.040
BD5221G-1TR	2.081	2.119	2.058	2.142
BD5222G-1TR	2.180	2.220	2.156	2.244
BD5223G-1TR	2.279	2.321	2.254	2.346
BD5224G-1TR	2.378	2.422	2.352	2.448
BD5225G-1TR	2.477	2.523	2.450	2.550
BD5226G-1TR	2.576	2.624	2.548	2.652
BD5227G-1TR	2.675	2.725	2.646	2.754
BD5228G-1TR	2.774	2.826	2.744	2.856
BD5229G-1TR	2.873	2.927	2.842	2.958
BD5230G-1TR	2.973	3.027	2.940	3.060
BD5231G-1TR	3.072	3.128	3.038	3.162
BD5232G-1TR	3.171	3.229	3.136	3.264
BD5233G-1TR	3.270	3.330	3.234	3.366
BD5234G-1TR	3.369	3.431	3.332	3.468
BD5235G-1TR	3.468	3.532	3.430	3.570
BD5236G-1TR	3.567	3.633	3.528	3.672
BD5237G-1TR	3.666	3.734	3.626	3.774
BD5238G-1TR	3.765	3.835	3.724	3.876
BD5239G-1TR	3.864	3.936	3.822	3.978
BD5240G-1TR	3.964	4.036	3.920	4.080
BD5241G-1TR	4.063	4.137	4.018	4.182
BD5242G-1TR	4.162	4.238	4.116	4.284
BD5243G-1TR	4.261	4.339	4.214	4.386
BD5244G-1TR	4.360	4.440	4.312	4.488
BD5245G-1TR	4.459	4.541	4.410	4.590
BD5246G-1TR	4.558	4.642	4.508	4.692
BD5247G-1TR	4.657	4.743	4.606	4.794
BD5248G-1TR	4.756	4.844	4.704	4.896
BD5249G-1TR	4.855	4.945	4.802	4.998
BD5250G-1TR	4.955	5.045	4.900	5.100

(Note 1) Not 100 % tested.

Typical Performance Curves

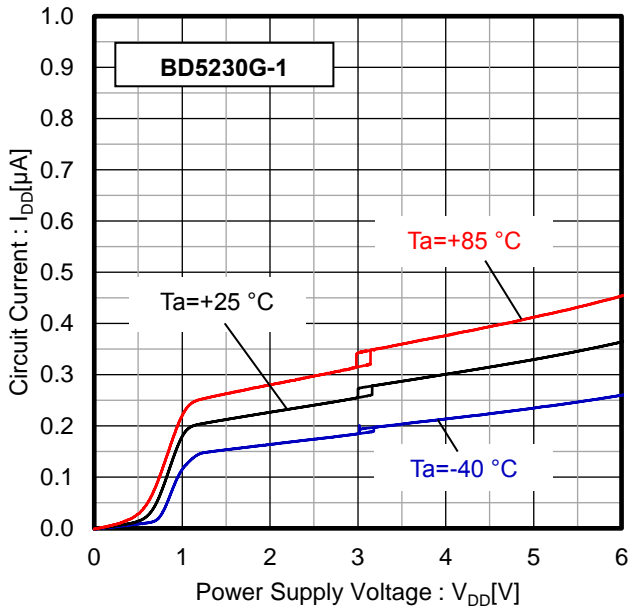

Figure 3. Circuit Current vs Power Supply Voltage

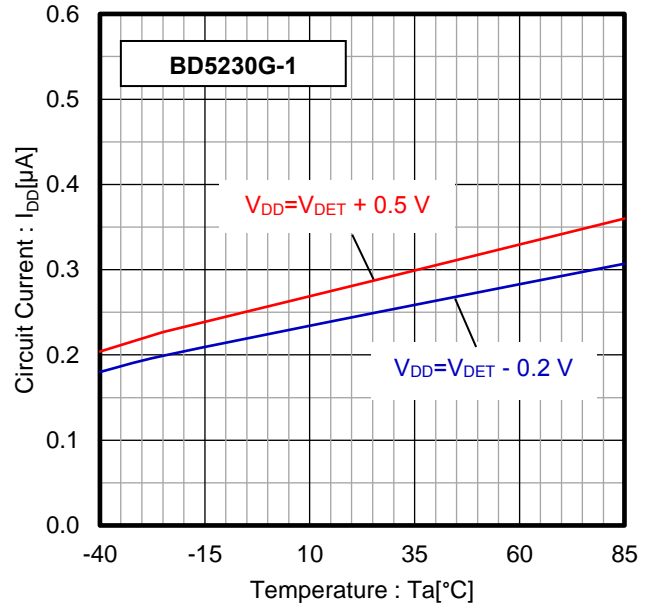

Figure 4. Circuit Current vs Temperature

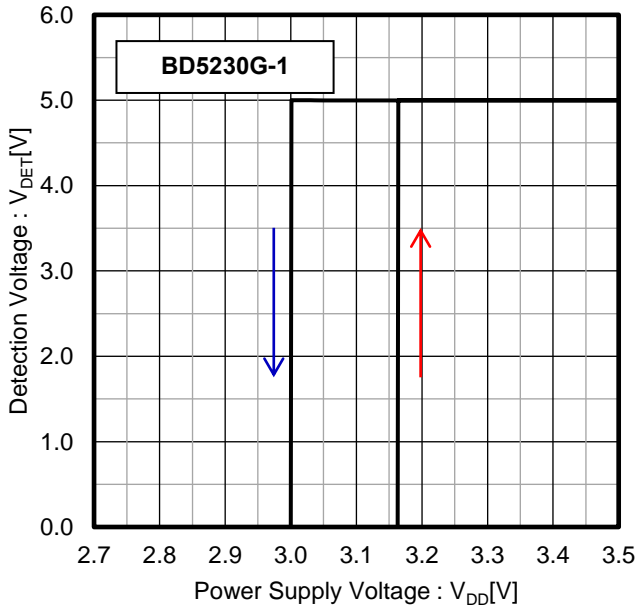

Figure 5. Detection Voltage vs Power Supply Voltage

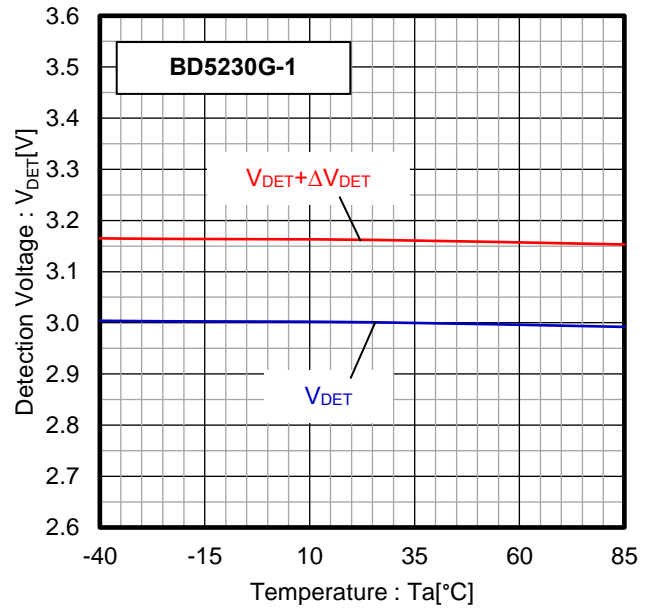

Figure 6. Detection Voltage vs Temperature

Typical Performance Curves - continued

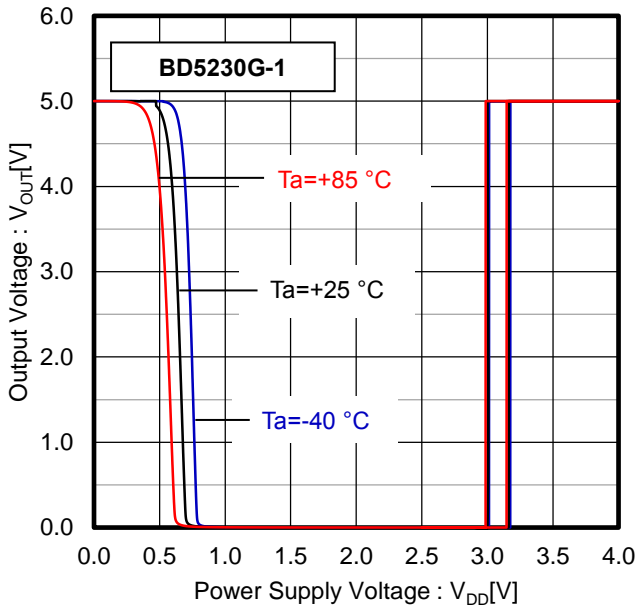

Figure 7. I/O Characteristics  
(V<sub>OUT</sub> Pull-up to 5 V, R<sub>L</sub> = 100 kΩ)

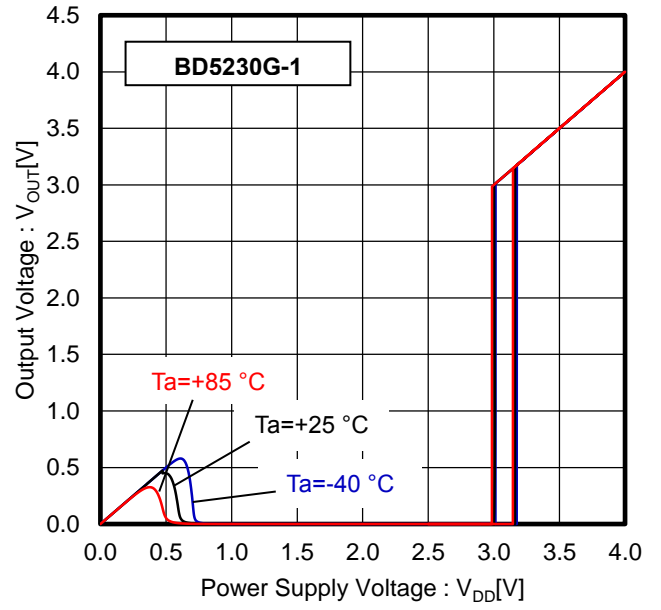

Figure 8. I/O Characteristics  
(V<sub>OUT</sub> Pull-up to V<sub>DD</sub>, R<sub>L</sub> = 100 kΩ)

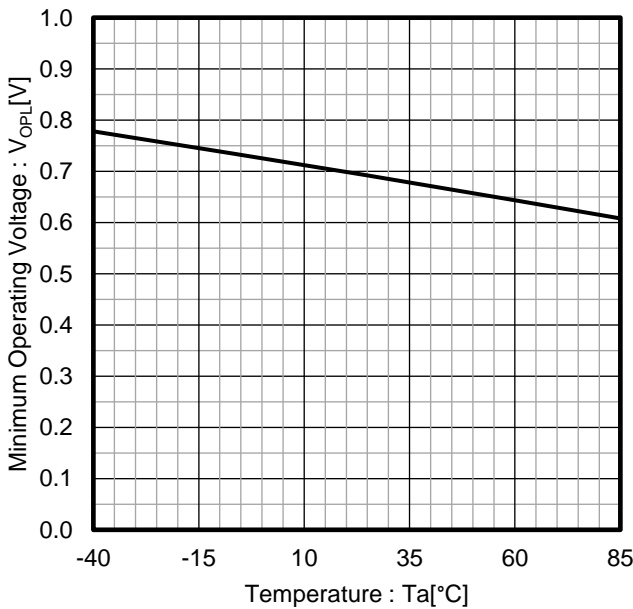

Figure 9. Minimum Operating Voltage vs Temperature  
(V<sub>OUT</sub> Pull-up to 5 V, R<sub>L</sub> = 100 kΩ)

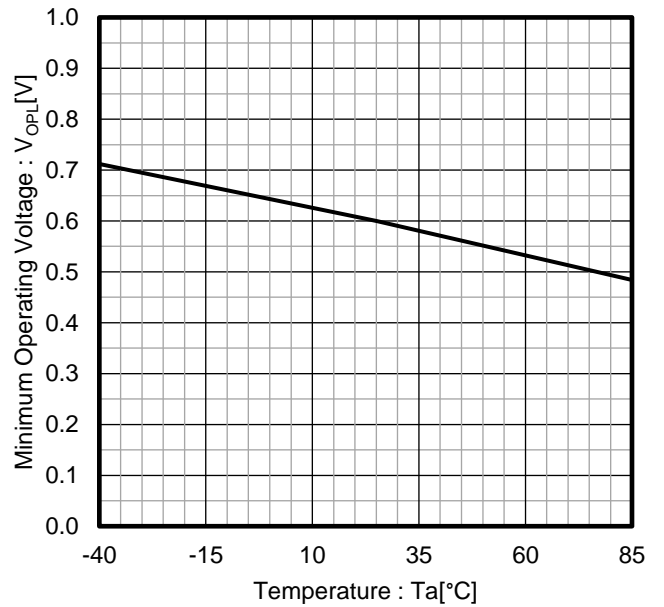

Figure 10. Minimum Operating Voltage vs Temperature  
(V<sub>OUT</sub> Pull-up to V<sub>DD</sub>, R<sub>L</sub> = 100 kΩ)

Typical Performance Curves - continued

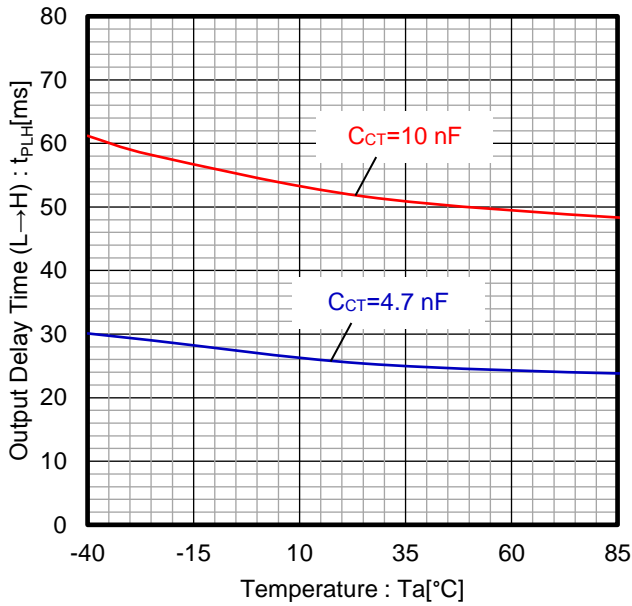

Figure 11. Output Delay Time (L→H) vs Temperature

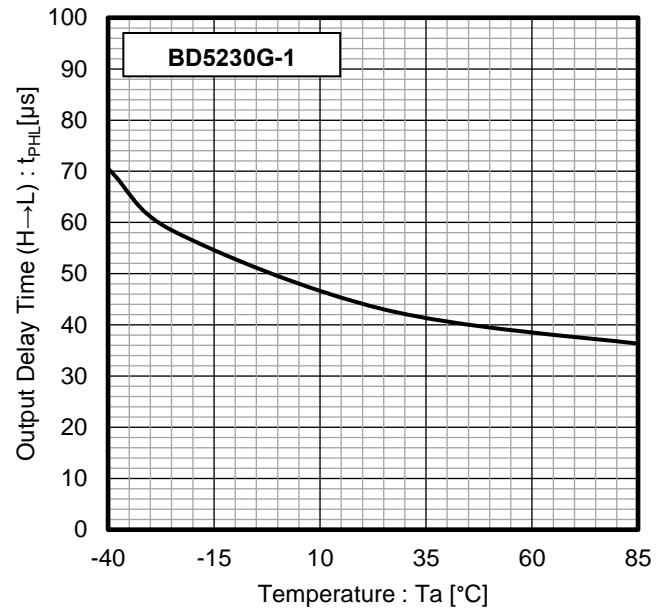

Figure 12. Output Delay Time (H→L) vs Temperature

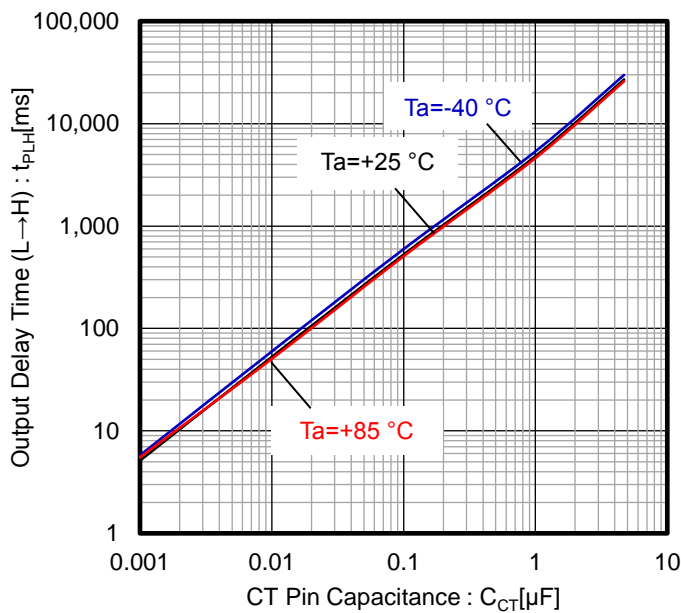

Figure 13. Output Delay Time (L→H) vs CT Pin Capacitance

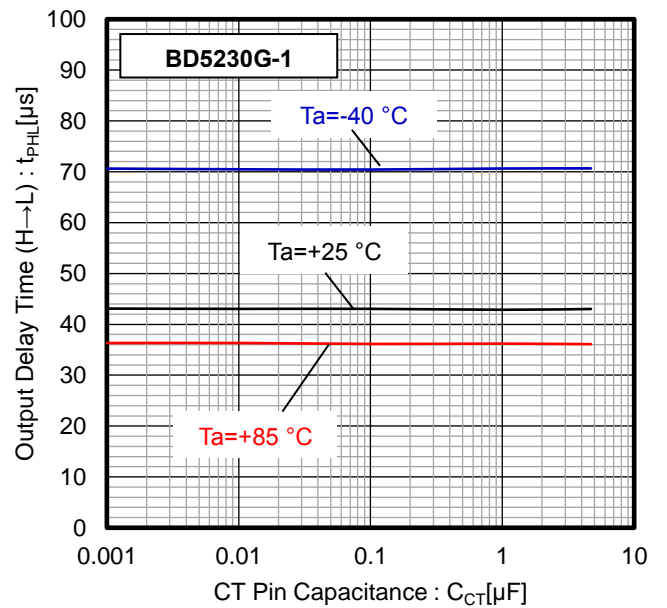

Figure 14. Output Delay Time (H→L) vs CT Pin Capacitance

Typical Performance Curves - continued

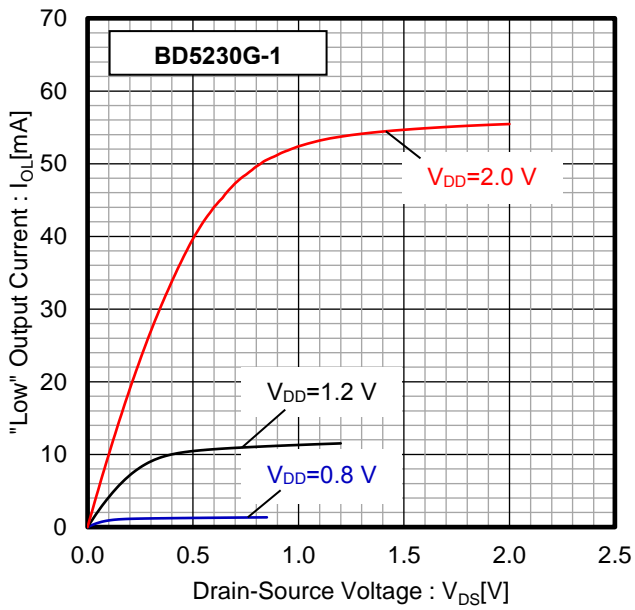

Figure 15. "Low" Output Current vs Drain-Source Voltage

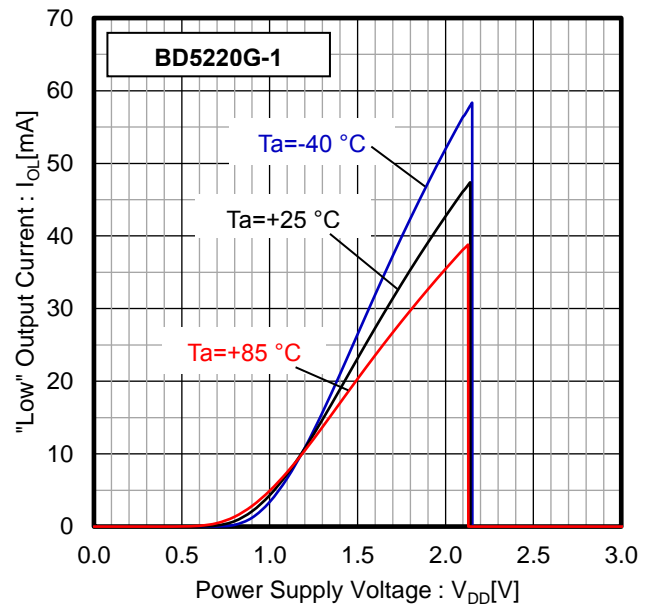

Figure 16. "Low" Output Current vs Power Supply Voltage ( $V_{DS} = 0.5$  V)

Application Information

Operation Description

For the open drain type (Figure 17), the detection and release voltage are used as threshold voltages. When the voltage applied to the V<sub>DD</sub> reaches the applicable threshold voltage, the V<sub>OUT</sub> level switches from either “H”→“L” or from “L”→“H”. BD52xxG-1 series have delay time function, which set t<sub>PLH</sub> (output “L”→“H”) using an external capacitor connected in CT pin (C<sub>CT</sub>).

Because the BD52xxG-1 series uses an open drain output type, it is necessary to connect a pull up resistor to V<sub>DD</sub> or another power supply. [In this case, the output (V<sub>OUT</sub>) “H” voltage becomes V<sub>DD</sub> or the voltage of the other power supply].

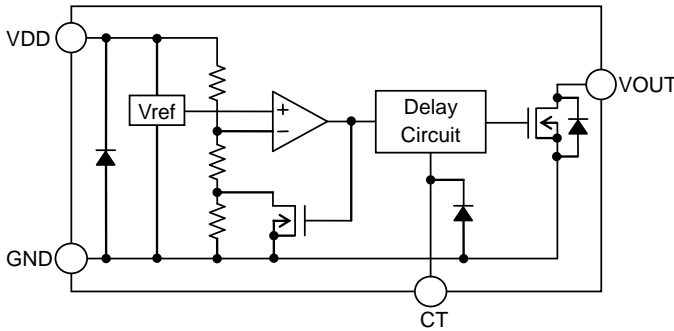

Figure 17. BD52xxG-1 type internal block diagram

Setting of Detector Delay Time

Delay time L→H (t<sub>PLH</sub>) is the time when V<sub>OUT</sub> rises to 1/2 of V<sub>DD</sub> after V<sub>DD</sub> rises up and beyond the release voltage (V<sub>DET</sub>+ΔV<sub>DET</sub>).

Delay time L→H (t<sub>PLH</sub>) is determined by CT capacitor and can be calculated from the following formula. When CT capacitor ≥ 1 nF, t<sub>CTO</sub> has less effect and t<sub>PLH</sub> computation is shown on Example No.2. The result has ±30 % tolerance within the operating temperature range of -40 °C to +85 °C (design guarantee).

Formula: (T<sub>a</sub> = 25 °C)

$$t_{PLH} = C_{CT} \times Delay\ Coefficient + t_{CTO} \quad [s]$$

where:

C<sub>CT</sub> is the CT pin external capacitor

Delay Coefficient is equal to 5.55 x 10<sup>6</sup>

t<sub>CTO</sub> is the delay time when CT=open (Note1)

Temperature	Delay Time (t <sub>CTO</sub> )		
	Min	Typ	Max
T <sub>a</sub> = -40 °C to +85 °C	15 μs	50 μs	150 μs

(Note1) t<sub>CTO</sub> is design guarantee only

Example No.1:

CT capacitor = 100 pF

$$t_{PLH\_min} = (100 \times 10^{-12} \times 5.55 \times 10^6) \times 0.7 + 15 \times 10^{-6} = 403 \mu s$$

$$t_{PLH\_typ} = (100 \times 10^{-12} \times 5.55 \times 10^6) \times 1.0 + 50 \times 10^{-6} = 605 \mu s$$

$$t_{PLH\_max} = (100 \times 10^{-12} \times 5.55 \times 10^6) \times 1.3 + 150 \times 10^{-6} = 872 \mu s$$

Example No.2:

CT capacitor = 1 nF

$$t_{PLH\_typ} = 1 \times 10^{-9} \times 5.55 \times 10^6 = 5.55 ms$$

Application Information - continued

Timing Waveform

The following shows the relationship between the input voltage  $V_{DD}$  and the output voltage  $V_{OUT}$  when the power supply voltage  $V_{DD}$  is sweep up and sweep down.

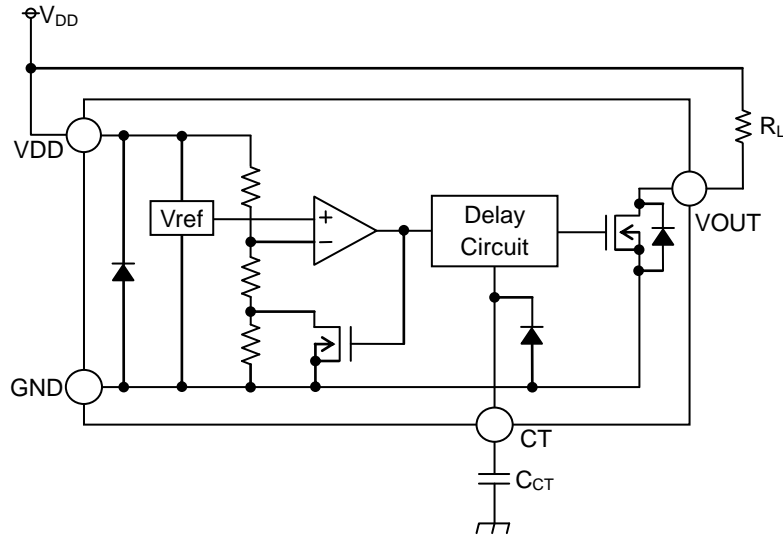

Figure 18. BD52xxG-1 Set-up

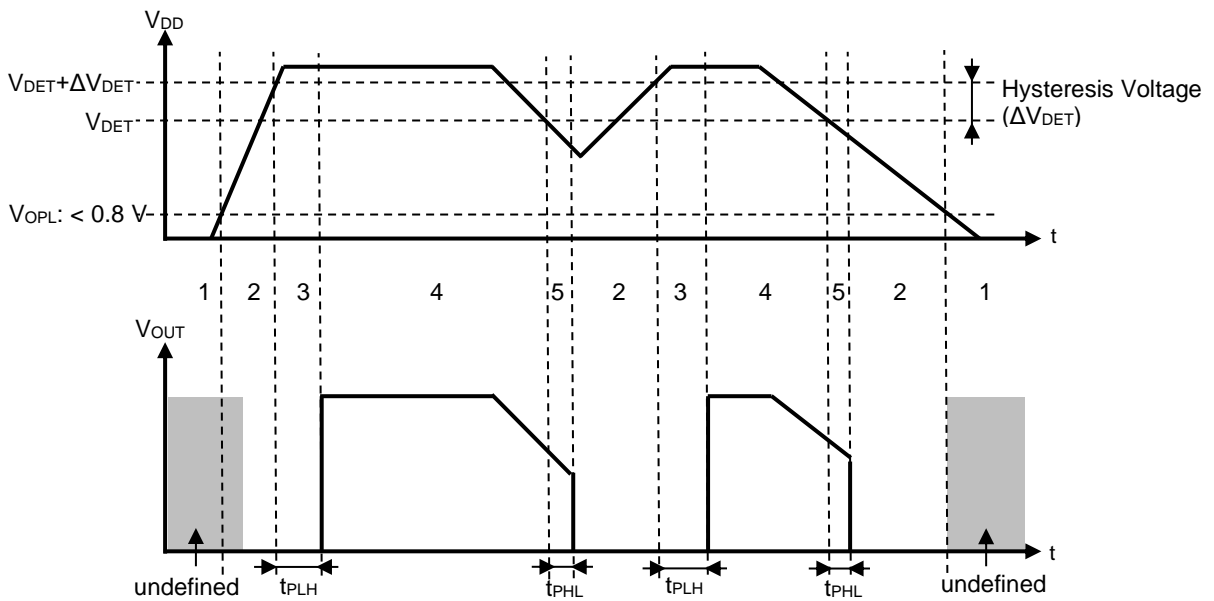

Figure 19. Timing Diagram

Operating Conditions Explanation

- 1 When the power supply turns on, the Output Voltage ( $V_{OUT}$ ) becomes unstable until  $V_{DD}$  exceeds the Minimum Operating Voltage ( $V_{OPL}$ ).
- 2  $V_{OUT}$  changes to "L". However, this change depends on the  $V_{OUT}$  rise time when the power supply starts up, so thorough confirmation is required.
- 3 When  $V_{DD}$  exceeds the release voltage ( $V_{DET} + \Delta V_{DET}$ ), delay time ( $t_{PLH}$ ) set by the capacitor at CT pin ( $C_{CT}$ ) happens, then  $V_{OUT}$  switches from "L" to "H".
- 4  $V_{OUT}$  remains "H".
- 5 When  $V_{DD}$  drops below Detection Voltage ( $V_{DET}$ ), delay time ( $t_{PHL}$ ) happens, then  $V_{OUT}$  switches from "H" to "L".

The potential difference between the detection voltage and the release voltage is known as the Hysteresis Voltage width ( $\Delta V_{DET}$ ). The system is designed such that the output will not toggle with power supply fluctuations within this hysteresis width, preventing malfunctions due to noise.

Application Information – continued

**Bypass Capacitor for Noise Rejection**

To help reject noise, put more than 0.1  $\mu\text{F}$  capacitor between VDD and GND pin and connect it closer to the pin as possible. Be careful when using extremely big capacitor as transient response will be affected.

**External Parameters**

The recommended value of CT capacitor is from open to 4.7  $\mu\text{F}$  and pull-up resistance value is 50 k $\Omega$  to 1 M $\Omega$ . There are many factors (board layout, etc.) that can affect characteristics. Operating beyond the recommended values does not guarantee correct operation. Please verify and confirm using practical applications.

In addition, this IC has extremely high impedance pins. Small leak current due to the uncleanness of PCB surface might cause unexpected operations. Application values in these conditions should be selected carefully. For example, if a 10 M $\Omega$  leakage is assumed between VOUT and GND pin, consider to set the value of pull up resistor lower than 1/10 of the impedance of assumed leakage route.

**Behavior when below the Operating Voltage Limit**

When VDD falls below the minimum operating voltage, output will be open. When output is connected to pull-up voltage, output will be equivalent to pull-up voltage.

**CT Pin Discharge**

Due to the capabilities of the CT pin discharge transistor, the CT pin may not completely discharge when a short input pulse is applied, and in this case the delay time may not be controlled. Please verify the actual operation.

Application Circuits

(1) Examples of common application circuits

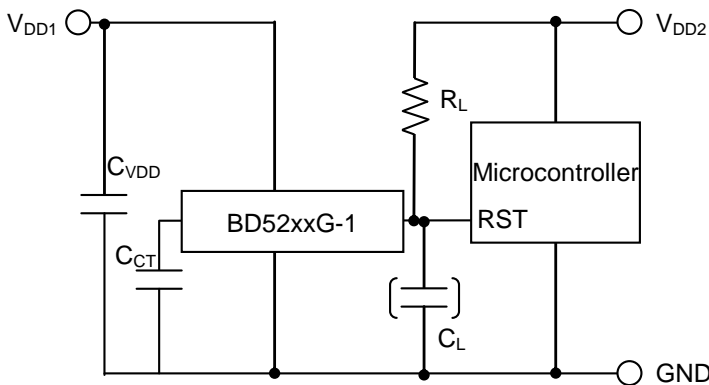

Figure 20. Open Drain Output Type

Application example of BD52xxG-1 series (Open drain output type) is shown below.

If the power supply of the microcontroller differs from the power supply of the detection (VDD1), use the load resistance R<sub>L</sub> connected to VDD2 in the output of open drain output type (BD52xxG-1 series) as shown in Figure 20.

When connecting a capacitor C<sub>L</sub> for noise elimination and for output time delay setting to VOUT pin (reset signal input pin of micro-controller), the waveform is dull during rising and falling of the output so use after confirmation that there is no problem.

Application Circuits - continued

(2) The following is an example of an OR connection between two types of detection voltage resets the microcontroller.

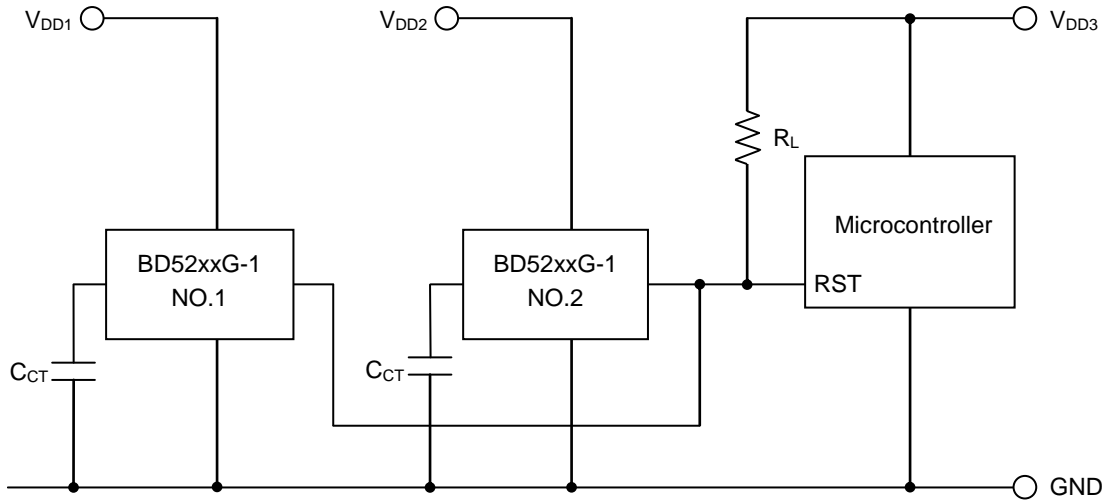

Figure 21. OR Circuit Connection Application

There are multiple power supply in the system, and in case monitoring for each independent power supply  $V_{DD1}$  and  $V_{DD2}$  and reset of micro-controller is required, an application where output “H” voltage is aligned to the microcontroller power supply  $V_{DD3}$  is possible by connecting OR application and pull-up at random voltage ( $V_{DD3}$ ) such as shown in Figure 21.

(3) Examples of the power supply with resistor dividers

In applications wherein the power supply voltage of an IC comes from a resistor divider circuit, an inrush current will flow into the circuit when the output level switches from “Low” to “High” or vice versa. Inrush current is a sudden surge of current that flows from the power supply ( $V_{DD}$ ) to ground (GND) as the output logic changes its state. This current flow may cause malfunction in the systems operation such as output oscillations, etc.

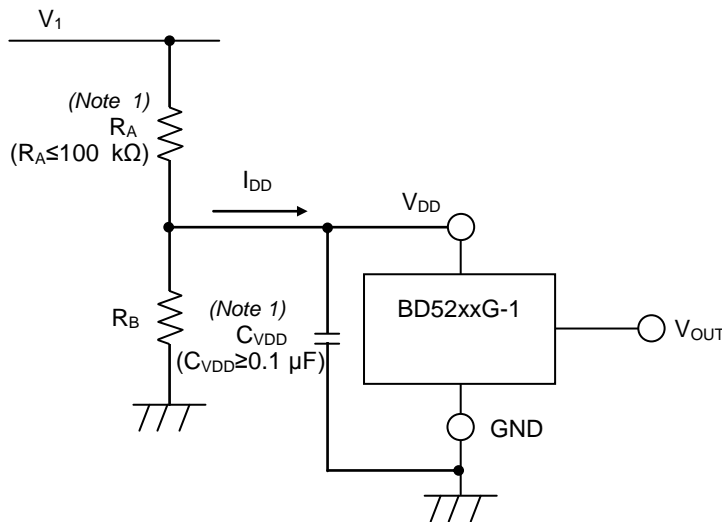

Figure 22. Resistor Divider Connection Application

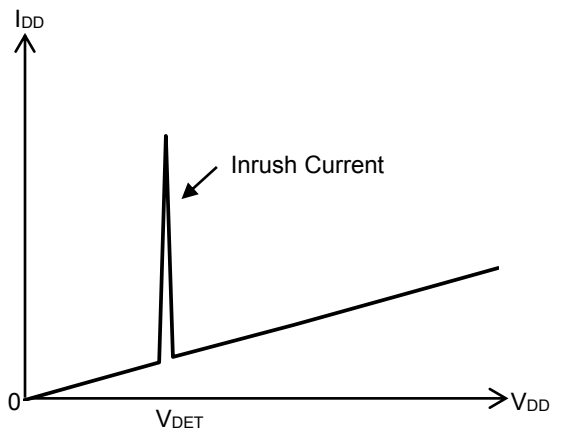

Figure 23. Current Consumption vs  $V_{DD}$  Voltage

A voltage drop [Inrush current ( $I_1$ ) × [input resistor ( $R_A$ )] is caused by the inrush current, and causes the input voltage to drop when the output switches from “L”→”H”. When the input voltage drops and falls below the detection voltage, the output will switch from “H”→”L”. At this time, the inrush current stops flowing through output “L”, and the voltage drop disappears. As a result, the output switches from “L”→”H”, which again causes the inrush current to flow and the voltage to drop. This operation repeats and leads to oscillation.

In case resistor divider is not use and only use  $R_A$ , same response will happen.

(Note 1) The circuit connection mentioned above does not guarantee successful operation. Perform thorough evaluation using the actual application and set countermeasures.

Application Circuits - continued

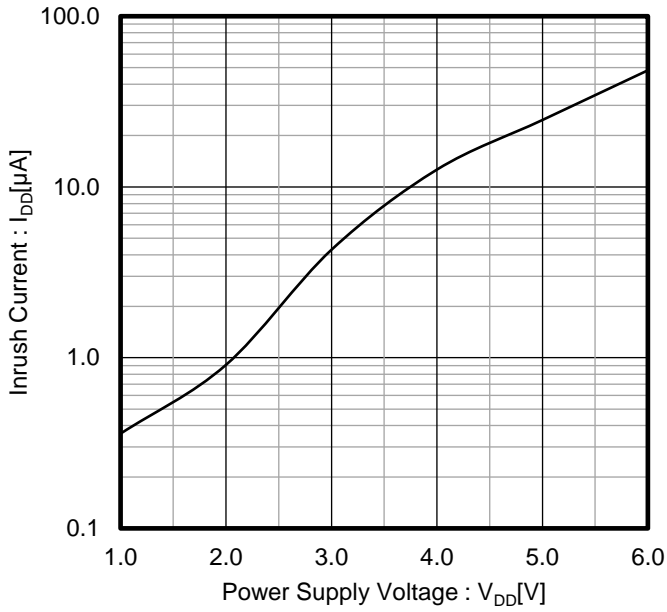

Figure 24.  $I_{DD}$  Inrush Current vs Power Supply Voltage ( $T_a = 25\text{ }^\circ\text{C}$ )

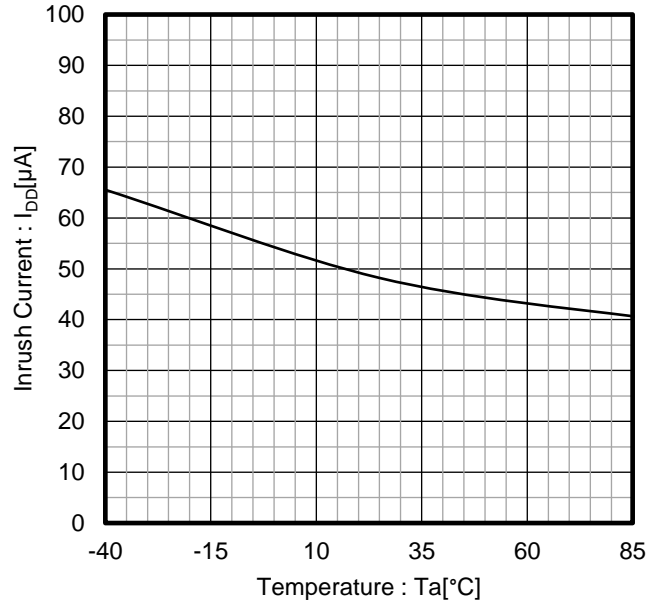

Figure 25.  $I_{DD}$  Inrush Current vs Temperature ( $V_{DD} = 6\text{ V}$ )

Depending on the application set-up, there are times that  $V_{DD}$  voltage is always below the Release Voltage ( $V_{DET} + \Delta V_{DET}$ ) because of the effect of inrush current as shown in Figure 26.

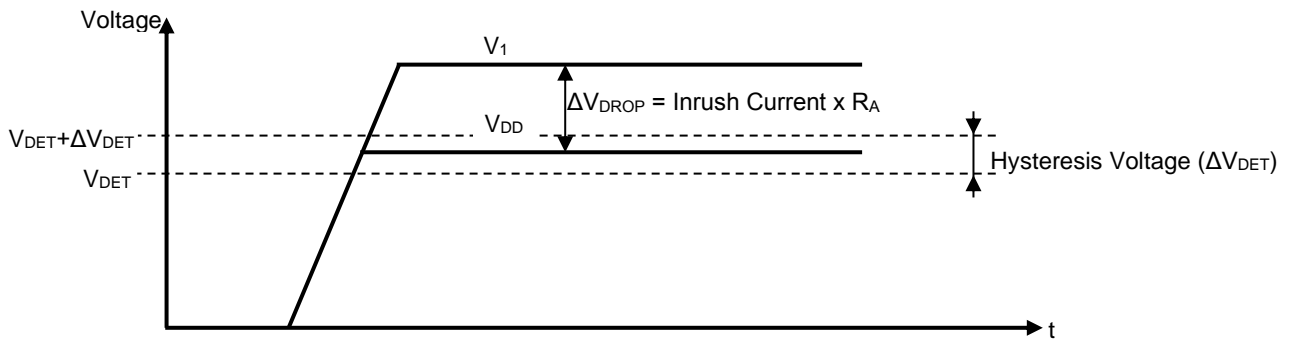

Figure 26.  $V_{DD}$  Drop Caused by Inrush Current

**Considerations on Input and Output Capacitor**

It is suggested to use input and output capacitors which is positioned as near as possible to the pins. The capacitor between the input pin and GND is effective when the power supply impedance increases or when the wiring is long. A large capacitor at the output improves stability and output load characteristics. Before implementation, check the state of mounting. In addition, the ceramic capacitor deviates in general and has temperature characteristics and AC bias characteristics. Furthermore, depending on the usage, the capacitance value decreases over time. It is recommended that ceramic capacitor to use is decided after gathering detailed data information by consulting brand manufacturers.

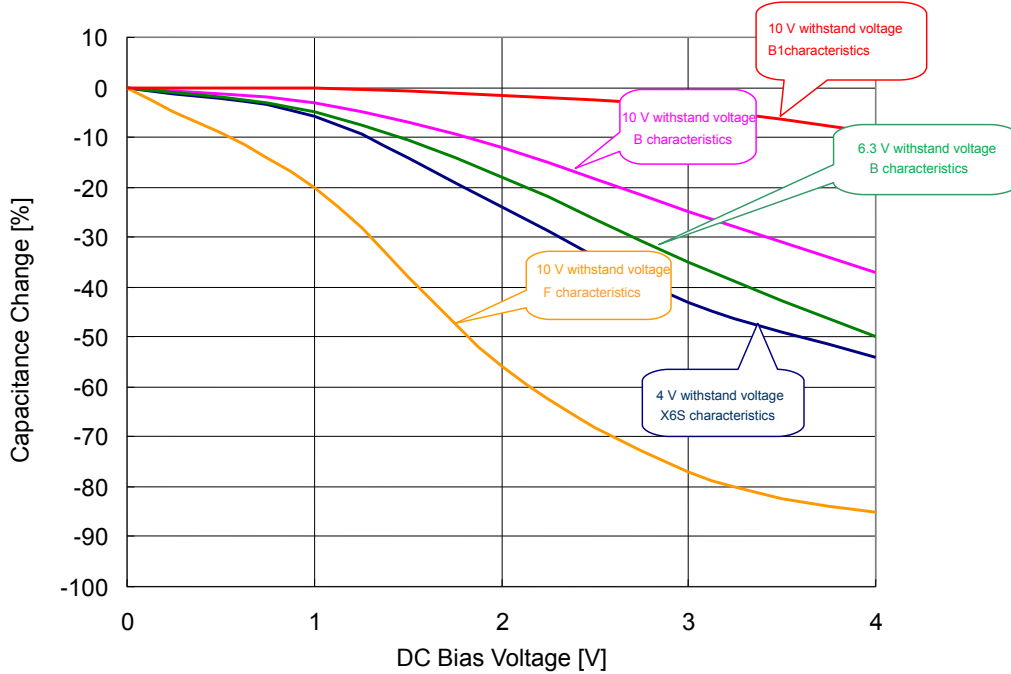

Figure 27. Ceramic Capacitance Change - DC Bias Properties (Characteristic example)

## Operational Notes

### 1. Reverse Connection of Power Supply

Connecting the power supply in reverse polarity can damage the IC. Take precautions against reverse polarity when connecting the power supply, such as mounting an external diode between the power supply and the IC's power supply pins.

### 2. Power Supply Lines

Design the PCB layout pattern to provide low impedance supply lines. Furthermore, connect a capacitor to ground at all power supply pins. Consider the effect of temperature and aging on the capacitance value when using electrolytic capacitors.

### 3. Ground Voltage

Ensure that no pins are at a voltage below that of the ground pin at any time, even during transient condition.

### 4. Ground Wiring Pattern

When using both small-signal and large-current ground traces, the two ground traces should be routed separately but connected to a single ground at the reference point of the application board to avoid fluctuations in the small-signal ground caused by large currents. Also ensure that the ground traces of external components do not cause variations on the ground voltage. The ground lines must be as short and thick as possible to reduce line impedance.

### 5. Recommended Operating Conditions

The function and operation of the IC are guaranteed within the range specified by the recommended operating conditions. The characteristic values are guaranteed only under the conditions of each item specified by the electrical characteristics.

### 6. Inrush Current

When power is first supplied to the IC, it is possible that the internal logic may be unstable and inrush current may flow instantaneously due to the internal powering sequence and delays, especially if the IC has more than one power supply. Therefore, give special consideration to power coupling capacitance, power wiring, width of ground wiring, and routing of connections.

### 7. Testing on Application Boards

When testing the IC on an application board, connecting a capacitor directly to a low-impedance output pin may subject the IC to stress. Always discharge capacitors completely after each process or step. The IC's power supply should always be turned off completely before connecting or removing it from the test setup during the inspection process. To prevent damage from static discharge, ground the IC during assembly and use similar precautions during transport and storage.

### 8. Inter-pin Short and Mounting Errors

Ensure that the direction and position are correct when mounting the IC on the PCB. Incorrect mounting may result in damaging the IC. Avoid nearby pins being shorted to each other especially to ground, power supply and output pin. Inter-pin shorts could be due to many reasons such as metal particles, water droplets (in very humid environment) and unintentional solder bridge deposited in between pins during assembly to name a few.

### 9. Unused Input Pins

Input pins of an IC are often connected to the gate of a MOS transistor. The gate has extremely high impedance and extremely low capacitance. If left unconnected, the electric field from the outside can easily charge it. The small charge acquired in this way is enough to produce a significant effect on the conduction through the transistor and cause unexpected operation of the IC. So unless otherwise specified, unused input pins should be connected to the power supply or ground line.

### 10. Regarding the Input Pin of the IC

In the construction of this IC, P-N junctions are inevitably formed creating parasitic diodes or transistors. The operation of these parasitic elements can result in mutual interference among circuits, operational faults, or physical damage. Therefore, conditions which cause these parasitic elements to operate, such as applying a voltage to an input pin lower than the ground voltage should be avoided. Furthermore, do not apply a voltage to the input pins when no power supply voltage is applied to the IC. Even if the power supply voltage is applied, make sure that the input pins have voltages within the values specified in the electrical characteristics of this IC.

### 11. Ceramic Capacitor

When using a ceramic capacitor, determine a capacitance value considering the change of capacitance with temperature and the decrease in nominal capacitance due to DC bias and others.

Physical Dimension and Packing Information

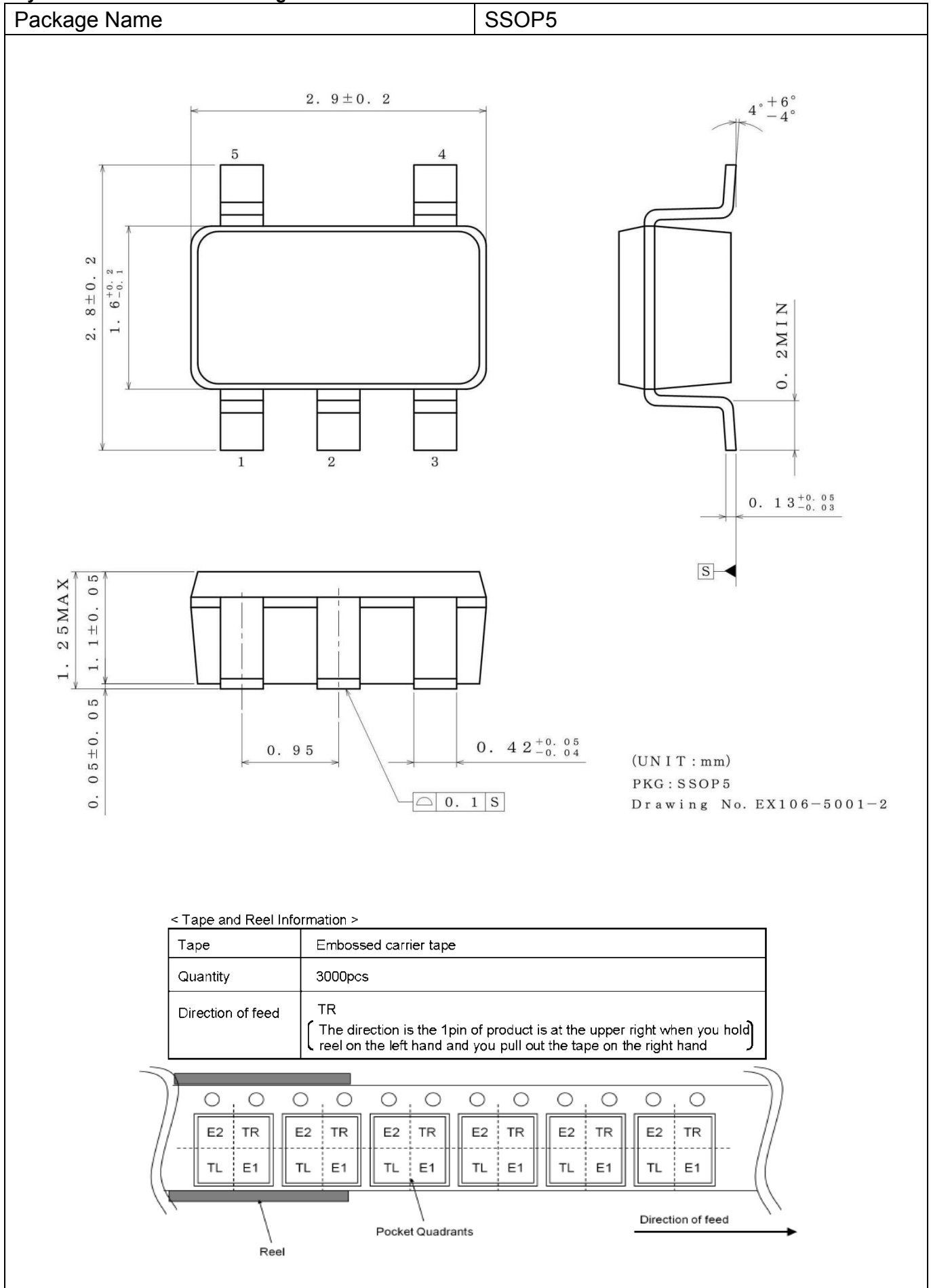

## Revision History

Date	Revision	Changes
23.Oct.2018	001	New Release
18.May.2023	002	Add Detection Voltage Lineup (3.2 V to 5.0 V)

# Notice

## Precaution on using ROHM Products

- Our Products are designed and manufactured for application in ordinary electronic equipment (such as AV equipment, OA equipment, telecommunication equipment, home electronic appliances, amusement equipment, etc.). If you intend to use our Products in devices requiring extremely high reliability (such as medical equipment <sup>(Note 1)</sup>, transport equipment, traffic equipment, aircraft/spacecraft, nuclear power controllers, fuel controllers, car equipment including car accessories, safety devices, etc.) and whose malfunction or failure may cause loss of human life, bodily injury or serious damage to property ("Specific Applications"), please consult with the ROHM sales representative in advance. Unless otherwise agreed in writing by ROHM in advance, ROHM shall not be in any way responsible or liable for any damages, expenses or losses incurred by you or third parties arising from the use of any ROHM's Products for Specific Applications.

(Note1) Medical Equipment Classification of the Specific Applications

JAPAN	USA	EU	CHINA
CLASS III	CLASS III	CLASS II b	CLASS III
CLASS IV		CLASS III	

- ROHM designs and manufactures its Products subject to strict quality control system. However, semiconductor products can fail or malfunction at a certain rate. Please be sure to implement, at your own responsibilities, adequate safety measures including but not limited to fail-safe design against the physical injury, damage to any property, which a failure or malfunction of our Products may cause. The following are examples of safety measures:
  - Installation of protection circuits or other protective devices to improve system safety
  - Installation of redundant circuits to reduce the impact of single or multiple circuit failure
- Our Products are designed and manufactured for use under standard conditions and not under any special or extraordinary environments or conditions, as exemplified below. Accordingly, ROHM shall not be in any way responsible or liable for any damages, expenses or losses arising from the use of any ROHM's Products under any special or extraordinary environments or conditions. If you intend to use our Products under any special or extraordinary environments or conditions (as exemplified below), your independent verification and confirmation of product performance, reliability, etc. prior to use, must be necessary:
  - Use of our Products in any types of liquid, including water, oils, chemicals, and organic solvents
  - Use of our Products outdoors or in places where the Products are exposed to direct sunlight or dust
  - Use of our Products in places where the Products are exposed to sea wind or corrosive gases, including Cl<sub>2</sub>, H<sub>2</sub>S, NH<sub>3</sub>, SO<sub>2</sub>, and NO<sub>2</sub>
  - Use of our Products in places where the Products are exposed to static electricity or electromagnetic waves
  - Use of our Products in proximity to heat-producing components, plastic cords, or other flammable items
  - Sealing or coating our Products with resin or other coating materials
  - Use of our Products without cleaning residue of flux (Exclude cases where no-clean type fluxes is used. However, recommend sufficiently about the residue.) ; or Washing our Products by using water or water-soluble cleaning agents for cleaning residue after soldering
  - Use of the Products in places subject to dew condensation
- The Products are not subject to radiation-proof design.
- Please verify and confirm characteristics of the final or mounted products in using the Products.
- In particular, if a transient load (a large amount of load applied in a short period of time, such as pulse, is applied, confirmation of performance characteristics after on-board mounting is strongly recommended. Avoid applying power exceeding normal rated power; exceeding the power rating under steady-state loading condition may negatively affect product performance and reliability.
- De-rate Power Dissipation depending on ambient temperature. When used in sealed area, confirm that it is the use in the range that does not exceed the maximum junction temperature.
- Confirm that operation temperature is within the specified range described in the product specification.
- ROHM shall not be in any way responsible or liable for failure induced under deviant condition from what is defined in this document.

## Precaution for Mounting / Circuit board design

- When a highly active halogenous (chlorine, bromine, etc.) flux is used, the residue of flux may negatively affect product performance and reliability.
- In principle, the reflow soldering method must be used on a surface-mount products, the flow soldering method must be used on a through hole mount products. If the flow soldering method is preferred on a surface-mount products, please consult with the ROHM representative in advance.

For details, please refer to ROHM Mounting specification

### Precautions Regarding Application Examples and External Circuits

1. If change is made to the constant of an external circuit, please allow a sufficient margin considering variations of the characteristics of the Products and external components, including transient characteristics, as well as static characteristics.
2. You agree that application notes, reference designs, and associated data and information contained in this document are presented only as guidance for Products use. Therefore, in case you use such information, you are solely responsible for it and you must exercise your own independent verification and judgment in the use of such information contained in this document. ROHM shall not be in any way responsible or liable for any damages, expenses or losses incurred by you or third parties arising from the use of such information.

### Precaution for Electrostatic

This Product is electrostatic sensitive product, which may be damaged due to electrostatic discharge. Please take proper caution in your manufacturing process and storage so that voltage exceeding the Products maximum rating will not be applied to Products. Please take special care under dry condition (e.g. Grounding of human body / equipment / solder iron, isolation from charged objects, setting of Ionizer, friction prevention and temperature / humidity control).

### Precaution for Storage / Transportation

1. Product performance and soldered connections may deteriorate if the Products are stored in the places where:
  - [a] the Products are exposed to sea winds or corrosive gases, including Cl<sub>2</sub>, H<sub>2</sub>S, NH<sub>3</sub>, SO<sub>2</sub>, and NO<sub>2</sub>
  - [b] the temperature or humidity exceeds those recommended by ROHM
  - [c] the Products are exposed to direct sunshine or condensation
  - [d] the Products are exposed to high Electrostatic
2. Even under ROHM recommended storage condition, solderability of products out of recommended storage time period may be degraded. It is strongly recommended to confirm solderability before using Products of which storage time is exceeding the recommended storage time period.
3. Store / transport cartons in the correct direction, which is indicated on a carton with a symbol. Otherwise bent leads may occur due to excessive stress applied when dropping of a carton.
4. Use Products within the specified time after opening a humidity barrier bag. Baking is required before using Products of which storage time is exceeding the recommended storage time period.

### Precaution for Product Label

A two-dimensional barcode printed on ROHM Products label is for ROHM's internal use only.

### Precaution for Disposition

When disposing Products please dispose them properly using an authorized industry waste company.

### Precaution for Foreign Exchange and Foreign Trade act

Since concerned goods might be fallen under listed items of export control prescribed by Foreign exchange and Foreign trade act, please consult with ROHM in case of export.

### Precaution Regarding Intellectual Property Rights

1. All information and data including but not limited to application example contained in this document is for reference only. ROHM does not warrant that foregoing information or data will not infringe any intellectual property rights or any other rights of any third party regarding such information or data.
2. ROHM shall not have any obligations where the claims, actions or demands arising from the combination of the Products with other articles such as components, circuits, systems or external equipment (including software).
3. No license, expressly or implied, is granted hereby under any intellectual property rights or other rights of ROHM or any third parties with respect to the Products or the information contained in this document. Provided, however, that ROHM will not assert its intellectual property rights or other rights against you or your customers to the extent necessary to manufacture or sell products containing the Products, subject to the terms and conditions herein.

### Other Precaution

1. This document may not be reprinted or reproduced, in whole or in part, without prior written consent of ROHM.
2. The Products may not be disassembled, converted, modified, reproduced or otherwise changed without prior written consent of ROHM.
3. In no event shall you use in any way whatsoever the Products and the related technical information contained in the Products or this document for any military purposes, including but not limited to, the development of mass-destruction weapons.
4. The proper names of companies or products described in this document are trademarks or registered trademarks of ROHM, its affiliated companies or third parties.

**General Precaution**

1. Before you use our Products, you are requested to carefully read this document and fully understand its contents. ROHM shall not be in any way responsible or liable for failure, malfunction or accident arising from the use of any ROHM's Products against warning, caution or note contained in this document.
2. All information contained in this document is current as of the issuing date and subject to change without any prior notice. Before purchasing or using ROHM's Products, please confirm the latest information with a ROHM sales representative.
3. The information contained in this document is provided on an "as is" basis and ROHM does not warrant that all information contained in this document is accurate and/or error-free. ROHM shall not be in any way responsible or liable for any damages, expenses or losses incurred by you or third parties resulting from inaccuracy or errors of or concerning such information.