

### Description

RailClamp® TVS arrays are ultra low capacitance ESD protection devices designed to protect high speed data interfaces. This series has been specifically designed to protect sensitive components which are connected to high-speed data and transmission lines from overvoltage caused by ESD (electrostatic discharge), CDE (Cable Discharge Events), and EFT (electrical fast transients).

The monolithic design incorporates surge rated, low capacitance steering diodes and a TVS diode in a single package. Each line has a typical capacitance of <math><0.2\text{pF}</math> to ground. The capacitance of each line is well matched for constant signal balance. A connection to the TVS is provided for protection of external voltage buses, such as those found in USB applications. They may be used to meet the ESD immunity requirements of IEC 61000-4-2, Level 4 ( $\pm 15\text{kV}$  air,  $\pm 8\text{kV}$  contact discharge).

The RClamp®0582N is qualified to AEC-Q100 Grade1 (-40 to +125°C) and is supplied in a 6-pin SLP1210N6 package. It measures 1.2 x 1.0 x 0.58mm.

### Features

- ◆ ESD protection for high-speed data lines to **IEC 61000-4-2 (ESD)  $\pm 20\text{kV}$  (air),  $\pm 12\text{kV}$  (contact)**
- ◆ **IEC 61000-4-4 (EFT) 40A (5/50ns)**
- ◆ Qualified to AEC-Q100 Grade1 (-40 to +125°C)
- ◆ Array of surge rated diodes with internal TVS Diode
- ◆ Small package saves board space
- ◆ Protects two I/O lines and a power line
- ◆ Low capacitance: 0.2pF typical
- ◆ Low clamping voltage
- ◆ Solid-state silicon-avalanche technology

### Mechanical Characteristics

- ◆ SLP1210N6 Package
- ◆ Pb-Free, Halogen Free, RoHS/WEEE Compliant
- ◆ Nominal Dimensions: 1.2 x 1.0 x 0.58 mm
- ◆ Lead Pitch: 0.4mm
- ◆ Lead Finish: NiPdAu
- ◆ Marking : Marking Code
- ◆ Packaging : Tape and Reel

### Applications

- ◆ Automobile USB
- ◆ MMC/SD Port
- ◆ Automobile Video Ports

### Circuit Diagram

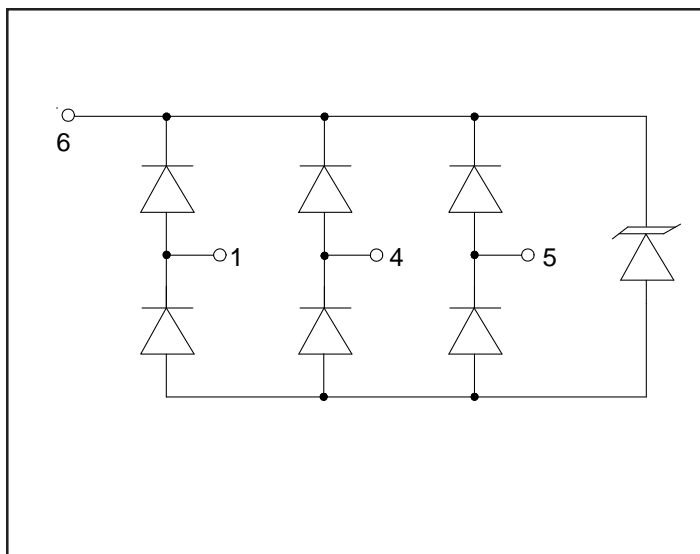

### Pin Configuration

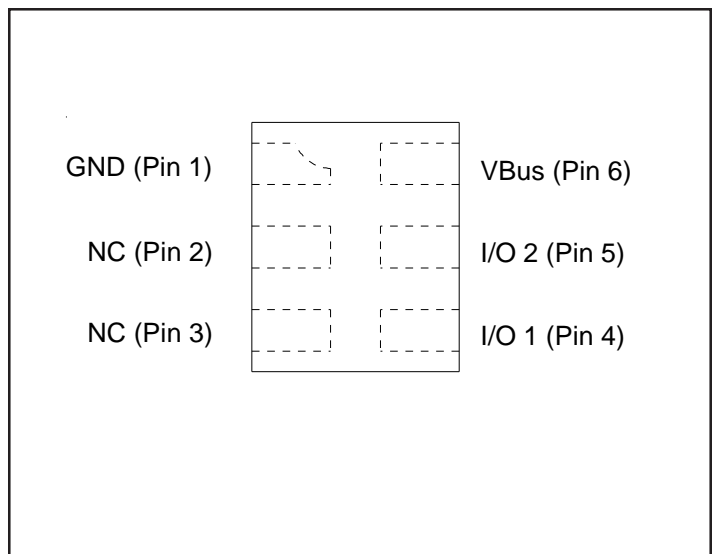

**PROTECTION PRODUCTS**
**Absolute Maximum Ratings**

| Rating   | Symbol    | Value       | Units |
|--|-----------|-------------|-------|
| Peak Pulse Power (tp = 8/20μs)                                 | $P_{pk}$  | 125         | Watts |
| Peak Pulse Current (tp = 8/20μs)                               | $I_{pp}$  | 5           | A     |
| ESD per IEC 61000-4-2 (Air)<br>ESD per IEC 61000-4-2 (Contact) | $V_{ESD}$ | ±20<br>±12  | kV    |
| Operating Temperature  | $T_J$     | -55 to +125 | °C    |
| Storage Temperature  | $T_{STG}$ | -55 to +150 | °C    |

**Electrical Characteristics (T=25°C unless otherwise specified)**

| Parameter                 | Symbol    | Conditions   | Minimum  | Typical | Maximum | Units |    |
|---------------------------|-----------|--|----------|---------|---------|-------|----|
| Reverse Stand-Off Voltage | $V_{RWM}$ | Pin 6 to GND   |          |         | 6.5     | V     |    |
| Reverse Breakdown Voltage | $V_{BR}$  | $I_t = 1mA$ ; Pin 6 to GND<br>T=-40 °C to 125 °C     | 7        | 9.5     | 12      | V     |    |
| Reverse Leakage Current   | $I_R$     | $V_{RWM} = 6.5V$ ,<br>Pin 6 to GND                   | T=25 °C  |         | 0.005   | 0.100 | μA |
|                           |           |  | T=125 °C |         |         | 0.200 | uA |
| Clamping Voltage          | $V_C$     | $I_{pp} = 1A$ , tp = 8/20μs<br>Any I/O pin to Ground |          |         | 15      | V     |    |
| Clamping Voltage          | $V_C$     | $I_{pp} = 5A$ , tp = 8/20μs<br>Any I/O pin to Ground |          |         | 25      | V     |    |
| Junction Capacitance      | $C_j$     | $V_R = 0V$ , f = 1MHz<br>Any I/O pin to Ground       |          | 0.2     | 0.5     | pF    |    |
|                           |           | $V_R = 0V$ , f = 1MHz<br>Between I/O pins            |          | 0.2     | 0.5     | pF    |    |

#### Non-Repetitive Peak Pulse Power vs. Pulse Time

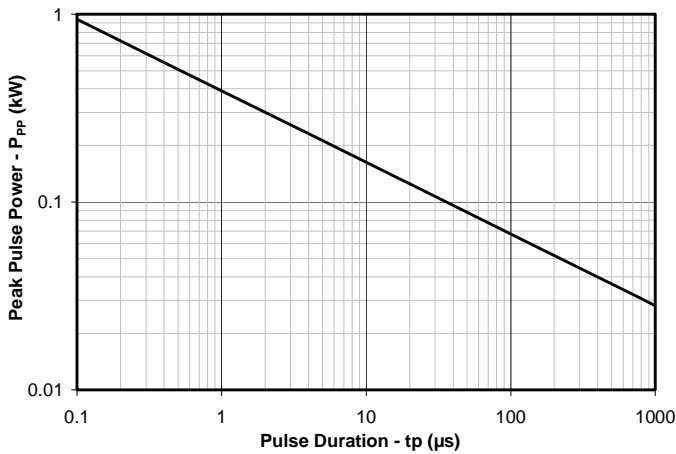

#### Power Derating Curve

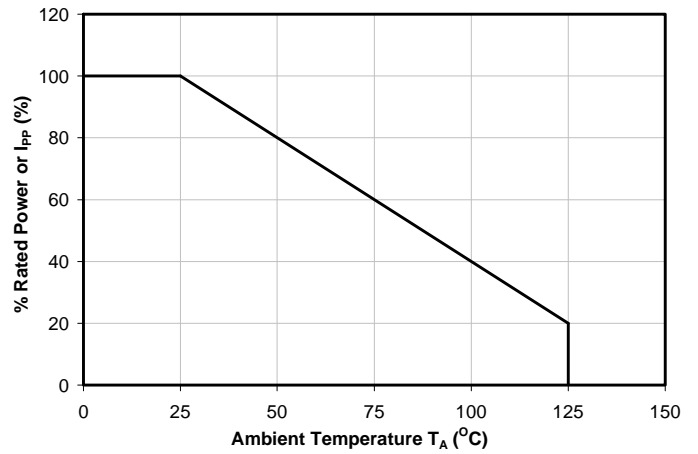

#### Clamping Voltage vs. Peak Pulse Current I/O to Gnd - Pin 4, 5 to Pin 1

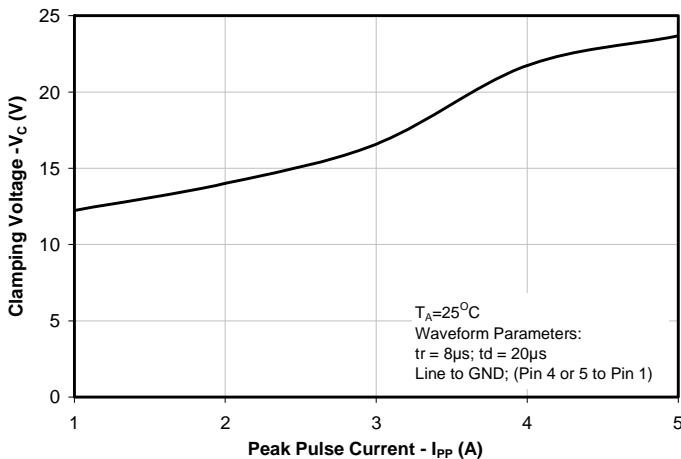

#### Normalize Capacitance vs. Reverse Voltage I/O to Gnd - Pin 4, 5 to Pin 1

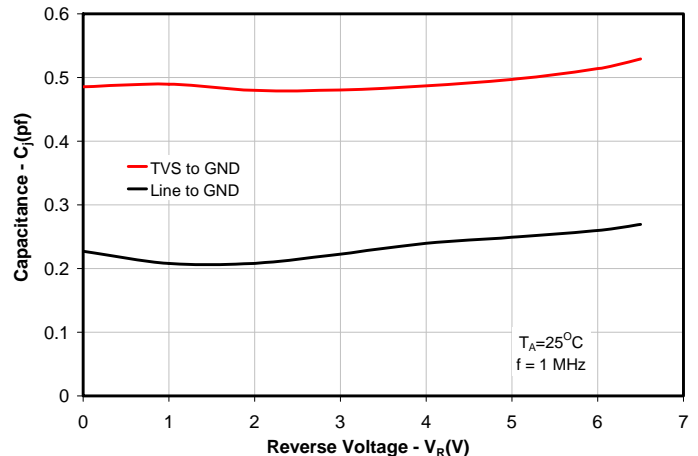

#### ESD Clamping (Contact per IEC 61000-4-2)

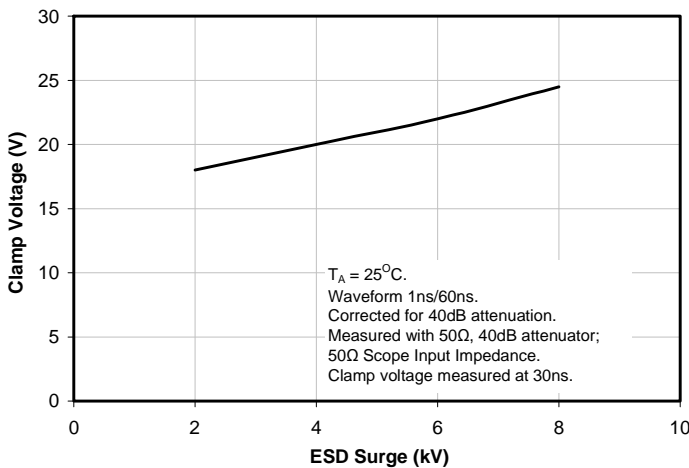

#### Insertion Loss

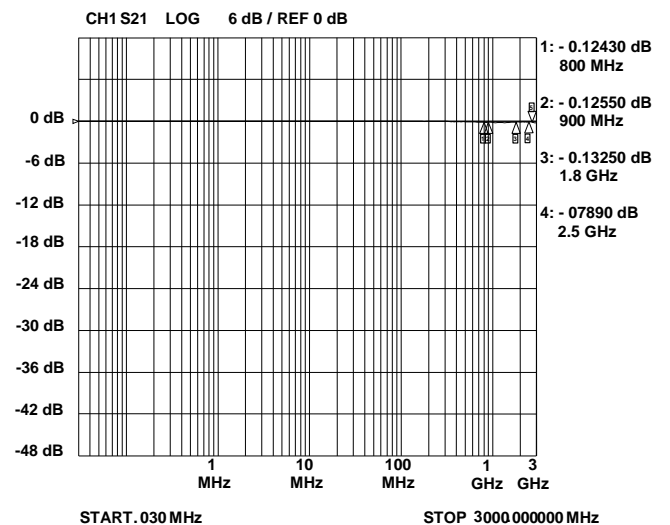

#### Capacitance v Temperature

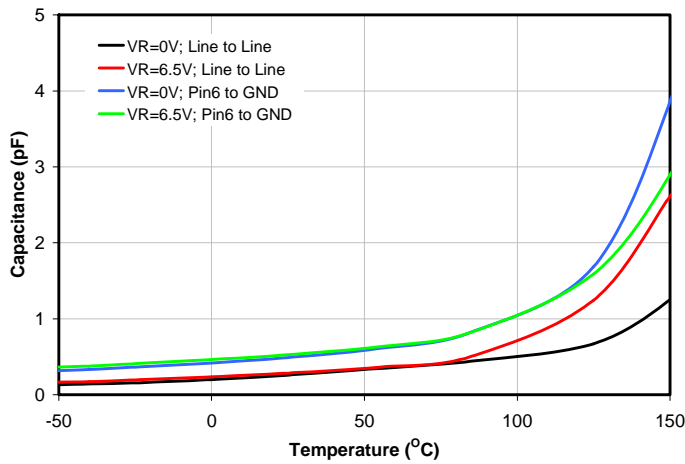

#### VF v Temperature

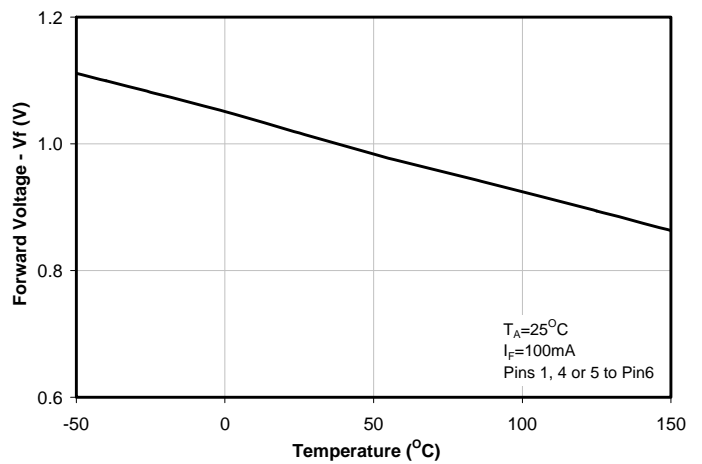

#### Breakdown Voltage v Temperature

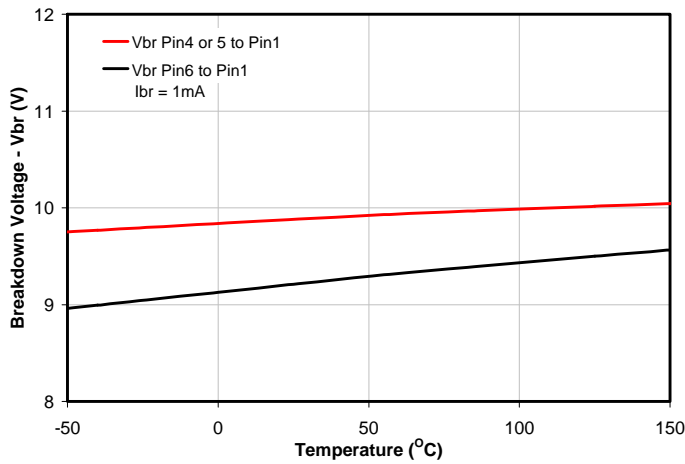

#### Leakage Current v Temperature

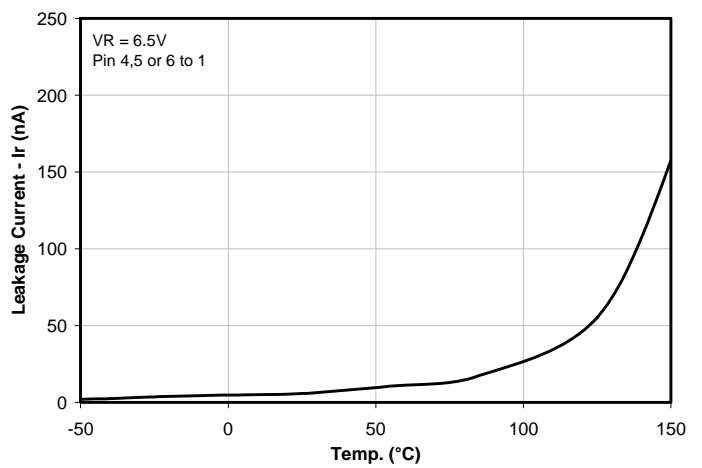

#### Crosstalk Pin 4 to Pin 5



#### Device Connection Options for Protection of Two High-Speed Data Lines

Data line inputs are normally connected at pins 4 & 5 with the outputs connected at pins 2 & 3. Pin 1 is connected to ground. Note that the circuit at the ground pin is identical to the circuit at each data input/output pin. This is done to further reduce capacitance. The connection to ground should be made directly to a ground plane. The path length should also be kept as short as possible to minimize parasitic inductance. Pin 6 can be connected to Vcc biased or left not connected depending upon the application.

Figure 1- Pin Configuration & Circuit Diagram

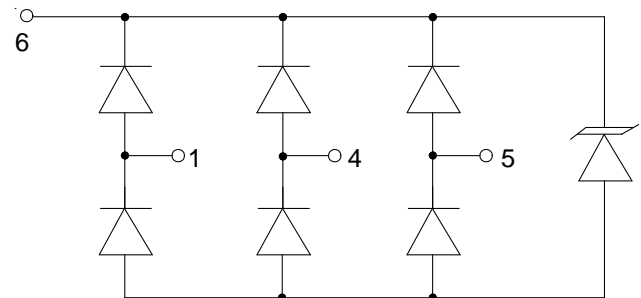

#### Protecting USB 2.0 Interfaces

The USB interface consists of Data (D- and D+) lines and a 5.25V voltage bus. Since these pins are part of the connector, they are vulnerable to ESD and cable discharge events. The RClamp0582NQ is designed to protect all four USB connections (VCC, D-, D+, and Gnd). Each device will protect one USB port. When the voltage on the data lines exceed the bus voltage (plus one diode drop), the internal rectifiers are forward biased conducting the transient current away from the protected controller chip. The TVS diode directs the surge to ground. The TVS diode also acts to suppress ESD strikes directly on the voltage bus. Thus, both power and data pins are protected with a single device.

Figure 2 - USB 2.0 High Speed Protection

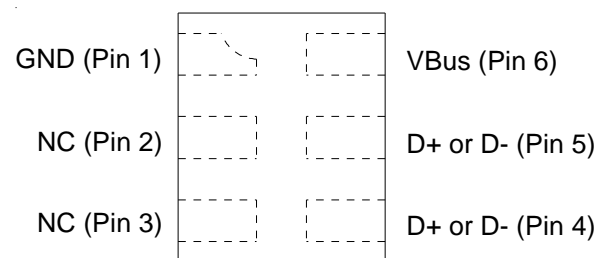

#### USB Controller

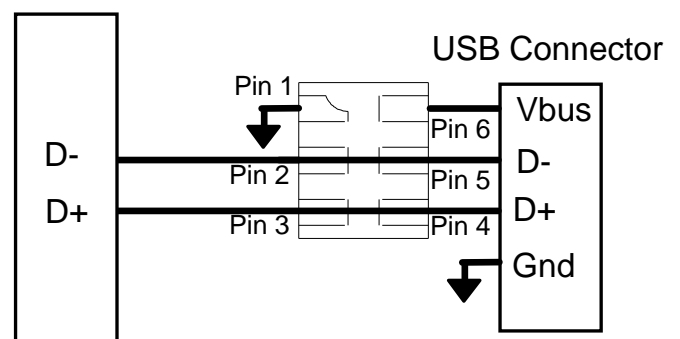

## PROTECTION PRODUCTS

### Outline Drawing - SLP1210N6

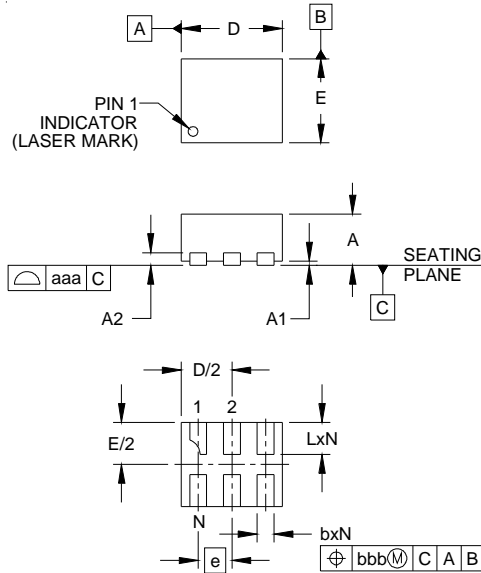

| DIM | INCHES |          |      | MILLIMETERS |          |       |
|-----|--------|----------|------|-------------|----------|-------|
|     | MIN    | NOM      | MAX  | MIN         | NOM      | MAX   |
| A   | .020   | .023     | .026 | 0.50        | 0.58     | 0.65  |
| A1  | 0.00   | .001     | .002 | 0.00        | 0.03     | 0.05  |
| A2  |        | (.005)   |      |             | (0.13)   |       |
| b   | .006   | .008     | .010 | 0.15        | 0.20     | 0.25  |
| D   | .043   | .047     | .051 | 1.10        | 1.20     | 1.30  |
| E   | .035   | .039     | .043 | 0.90        | 1.00     | 1.10  |
| e   |        | .016 BSC |      |             | 0.40 BSC |       |
| L   | .012   | .015     | .017 | 0.30        | 0.38     | 0.425 |
| N   |        | 6        |      |             | 6        |       |
| aaa |        | .003     |      |             | 0.08     |       |
| bbb |        | .004     |      |             | 0.10     |       |

NOTES:  
1. CONTROLLING DIMENSIONS ARE IN MILLIMETERS (ANGLES IN DEGREES).

### Land Pattern - SLP1210N6

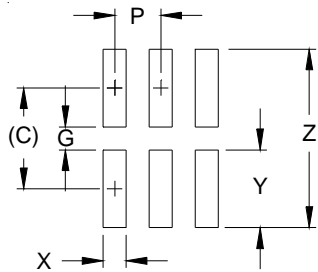

| DIM | DIMENSIONS |             |
|-----|------------|-------------|
|     | INCHES     | MILLIMETERS |
| C   | (.034)     | (0.875)     |
| G   | .008       | 0.20        |
| P   | .016       | 0.40        |
| X   | .008       | 0.20        |
| Y   | .027       | 0.675       |
| Z   | .061       | 1.55        |

NOTES:  
1. CONTROLLING DIMENSIONS ARE IN MILLIMETERS (ANGLES IN DEGREES).  
2. THIS LAND PATTERN IS FOR REFERENCE PURPOSES ONLY. CONSULT YOUR MANUFACTURING GROUP TO ENSURE YOUR COMPANY'S MANUFACTURING GUIDELINES ARE MET.

## PROTECTION PRODUCTS

### Marking Codes

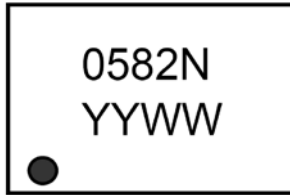

YYWW = Date Code

### Ordering Information

| Part Number     | Qty per Reel | Reel Size |
|-----------------|--------------|-----------|
| RClamp0582N.TCT | 3,000        | 7 Inch    |

RailClamp and RClamp are marks of Semtech Corporation

### Tape and Reel Specification

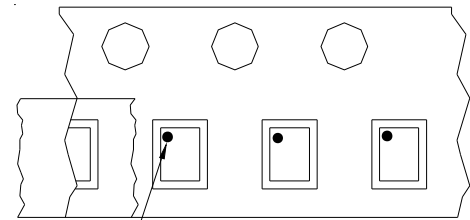
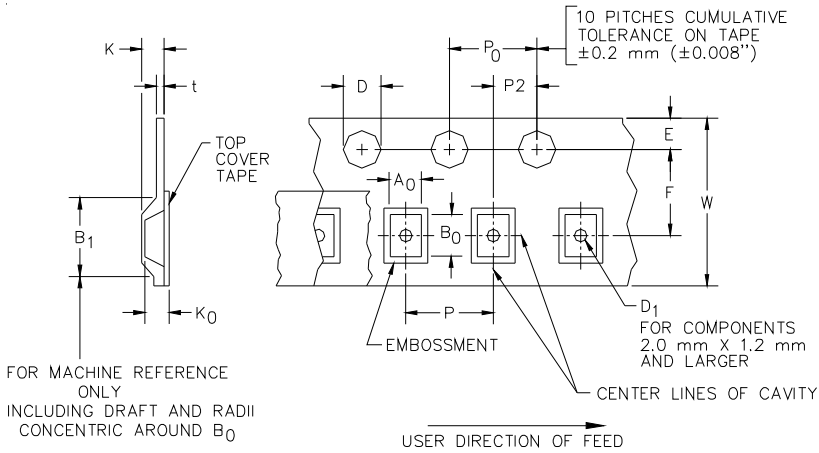

Pin 1 Location

→ User Direction of feed

### Device Orientation in Tape

| A0            | B0            | K0            |
|---------------|---------------|---------------|
| 1.21 ±0.10 mm | 1.41 ±0.10 mm | 0.74 ±0.10 mm |

| Tape Width | B, (Max)      | D   | D1                  | E                        | F                       | K (MAX)       | P                       | P0                      | P2                     | T(MAX)        | W                                     |
|------------|---------------|---|---------------------|--------------------------|-------------------------|---------------|-------------------------|-------------------------|------------------------|---------------|---------------------------------------|
| 8 mm       | 4.2 mm (.165) | 1.5 + 0.1 mm - 0.0 mm (0.59 +.005 - .000) | 0.8 mm ±0.05 (.031) | 1.750±.10 mm (.069±.004) | 3.5±0.05 mm (.138±.002) | 2.4 mm (.094) | 4.0±0.1 mm (.157±.00-4) | 4.0±0.1 mm (.157±.00-4) | 2.0±0.05mm (.079±.002) | 0.4 mm (.016) | 8.0 mm + 0.3 mm - 0.1 mm (.312±.012-) |

### Contact Information

Semtech Corporation  
 Protection Products Division  
 200 Flynn Road, Camarillo, CA 93012  
 Phone: (805)498-2111 FAX (805)498-3804

# Mouser Electronics

Authorized Distributor

Click to View Pricing, Inventory, Delivery & Lifecycle Information:

[Semtech:](#)

[RCLAMP0582N.TCT](#)