

HD

D-Sub connectors - Stamped and Formed Contacts

RIGHT ANGLE HIGH DENSITY CONNECTORS

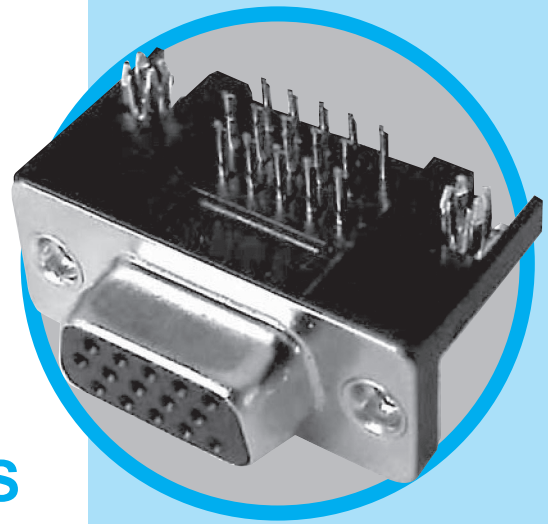

Specifications

- Connectors according to: MIL C24308

MAIN CHARACTERISTICS

Materials and Platings	
Shells	Steel, tin over nickel plating
Insulator	Glass-filled thermoplastic, UL 94V- 0
Pin contacts	Brass, selected gold in mating area; 2.54µm (100 µ") min.tin on termination area over 1.27µm (50µ") min.nickel
Socket contact	Phosphor bronze, selected gold in mating area;2.54µ(100µ") min.tin on termination area over 1.27µm (50µ") min.nickel
Rear insert	Brass, 2.54µm (100µ") min.nickel plated
Boardlock	Phosphor bronze or Brass, 2.54µm (100µ") min.nickel plated
Screwlock	Brass, 2.54µm (100µ") min.nickel plated

Electrical Data	
Current rating	3A
Voltage rating	250V AC/ rms 50Hz
Withstanding voltage	1000V AC/rms 50Hz for one minute
Insulation resistance	5000MΩ at 500V DC
Contact resistance	10mΩ max

Climatic Data	
Operating temperature	-55°C to +125°C
Salt spray	24 hours

Mechanical Data		
Single contact insertion force	0.34kg (0.75lb) max.	
Single contact withdrawal force	0.02kg (0.044lb) min.	
Mating and unmating force Unit: kg (lb)		
No. of Cts	Mate (max)	Unmate (min)
15	3.81 (8.42)	0.52 (1.14)
26	5.95 (13.16)	1.05 (2.32)
44	9.26 (20.46)	1.37 (3.02)
62	13.48 (29.78)	1.76 (3.88)
Standard plating thickness	<ul style="list-style-type: none"> • Gold flash • 0.4µm (15µ") Gold • 0.76 µm (30µ") Gold 	

DESCRIPTION

Amphenol's high density D-Sub connectors complement Amphenol's extensive D-Sub connector line. This line offers many superior features, high performance level and low installation cost.

The decreased contact spacing accommodates greater signal density in comparison to conventional D-Sub connectors.

Economical right angle PCB mount connectors

APPLICATIONS

- Industrial
- Telecom
- Any industry standard I / O connections



Amphenol

HD / E19

Shell size dimensions

Plug

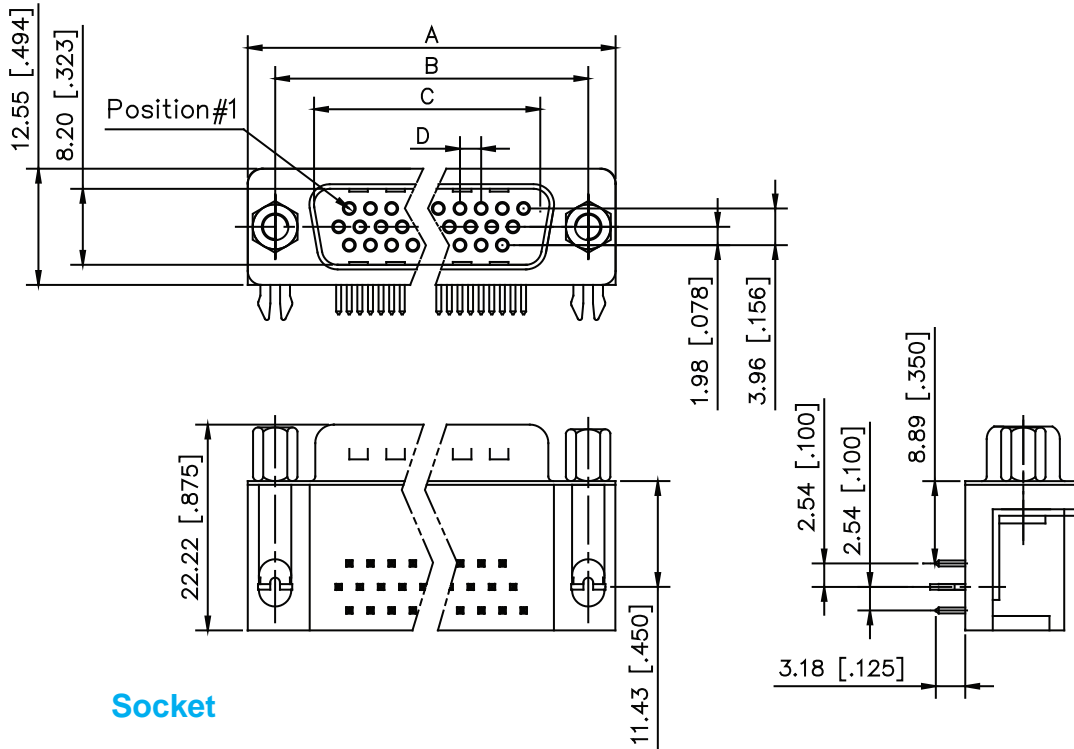

Socket

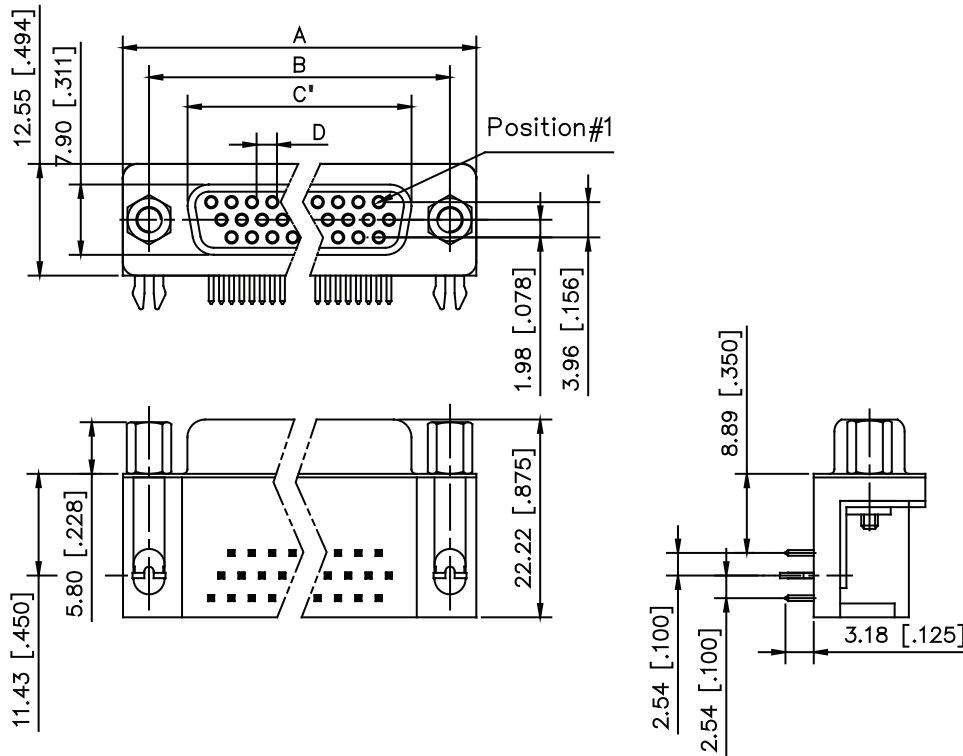

NB OF CONTACTS	DIMENSIONS mm (inch)				
	A	B	C	C'	D
15	30.84 (1.214)	24.99 (.984)	16.92 (.661)	16.26 (.640)	2.29 (.090)
26	39.24 (1.545)	33.32 (1.312)	25.25 (.994)	24.56 (.967)	2.29 (.090)
44	53.04 (2.088)	47.04 (1.852)	38.96 (1.534)	38.30 (1.508)	2.29 (.090)
62	69.34 (2.730)	63.50 (2.500)	55.42 (2.182)	54.76 (2.156)	2.41 (.095)

P.C.B. Layout

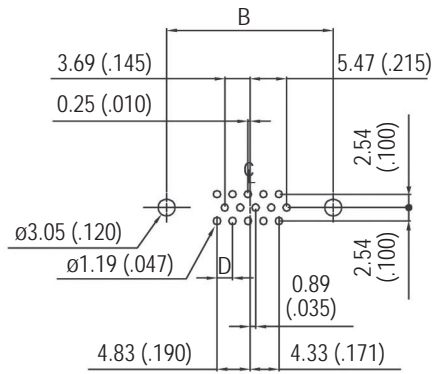

15 PIN

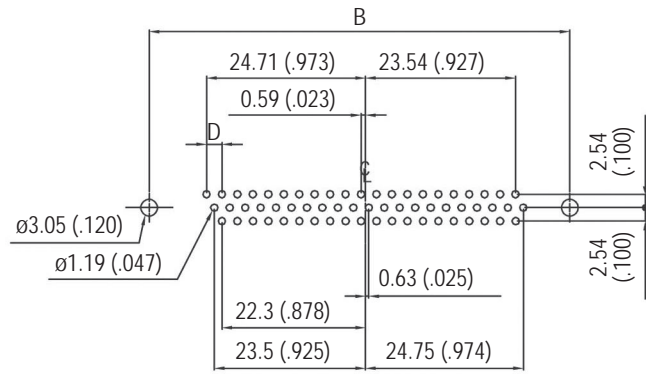

62 PIN

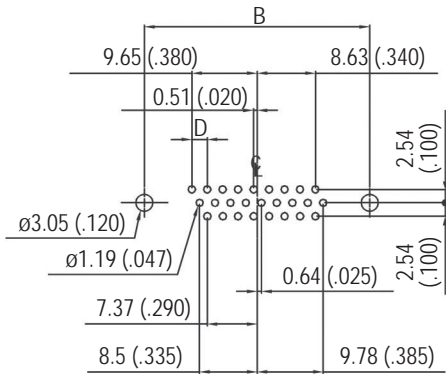

26 PIN

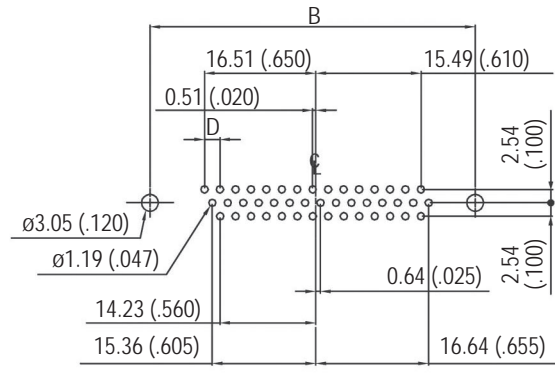

44 PIN

PCB layout for socket connector, top view

Panel mounting option

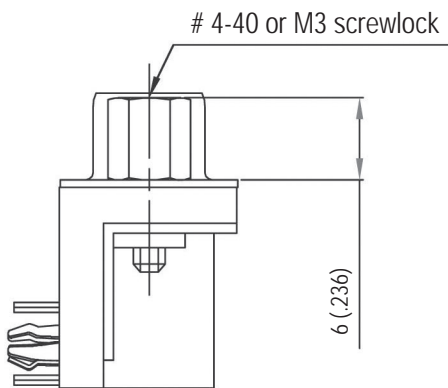

Front female screwlock
4F / 3F

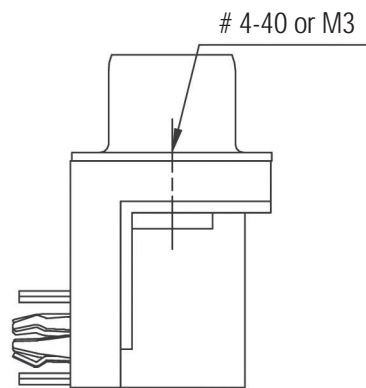

Threaded rear insert
4R / 3R



How to order

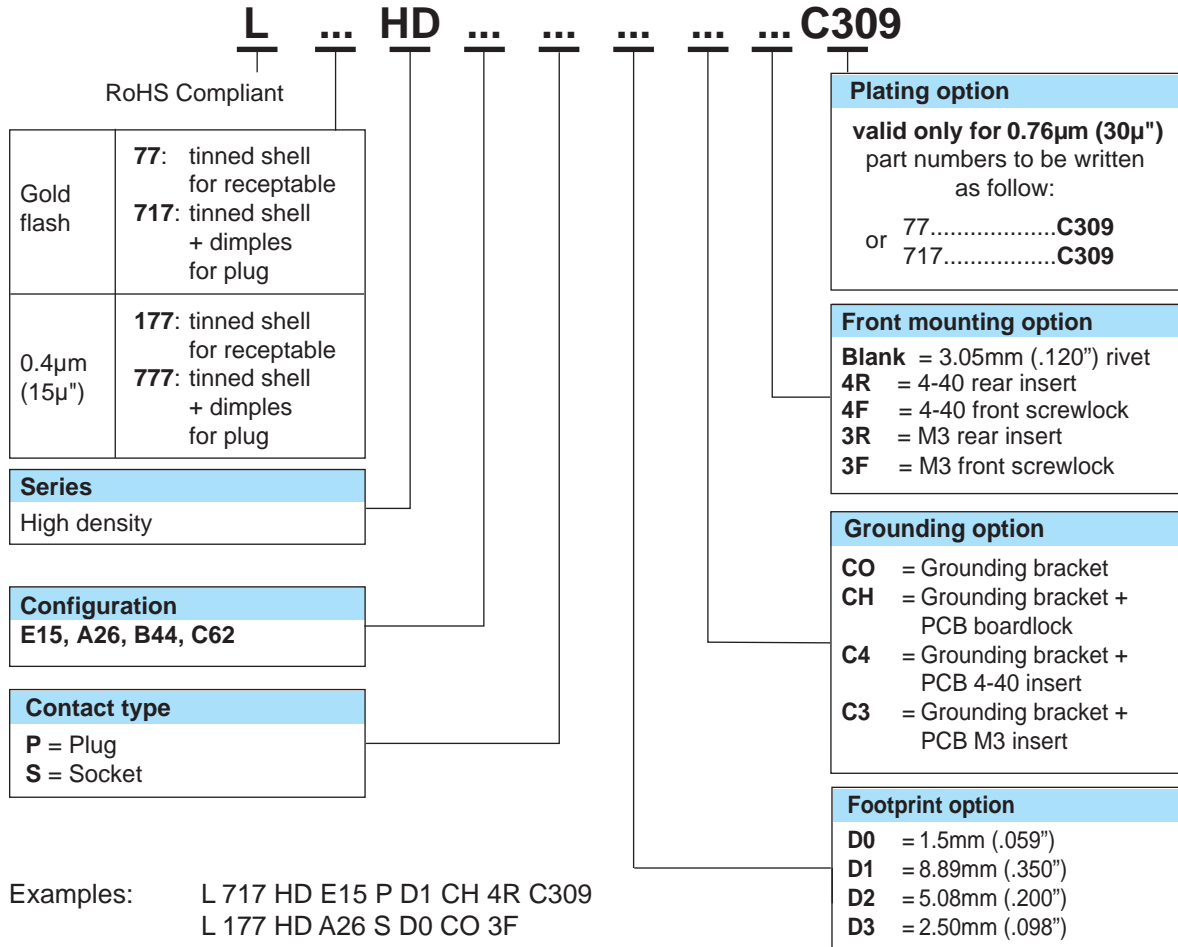

For special request, please consult factory

Do not hesitate to contact us for further information

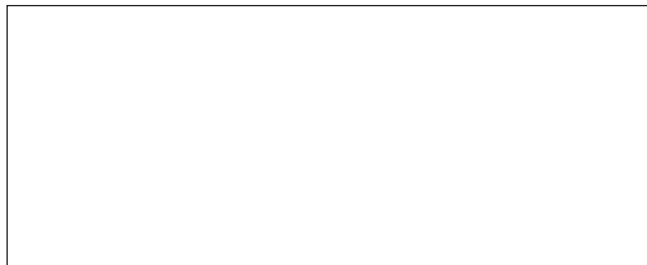

Amphenol

Amphenol IT & Communication Products

Block A3/A4, The 4th Industrial District of
 Industrial Headquarters, Dong Keng Road
 Gong Ming Town, Shen Zhen China
 Fax: +86(0)755 2754 9955

Technical Support

Tel: +86(0)755 2717 7945
 Info-dsub@amphenol.com.cn
 http://www.dsubconnector.com