

Aluminum Electrolytic Capacitors Power Ultra Long Life Snap-In

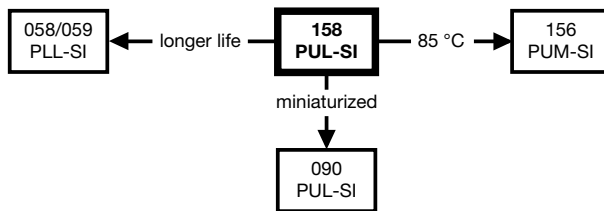

Fig. 1

QUICK REFERENCE DATA	
DESCRIPTION	VALUE
Nominal case sizes (Ø D x L in mm)	22 x 25 to 35 x 50
Rated capacitance range (E6 / E12 series), C _R	560 µF to 47 000 µF
Tolerance on C _R	± 20 %
Rated voltage range, U _R	16 V to 100 V
Category temperature range	-40 °C to +105 °C
Endurance test at 105 °C	2000 h
Useful life at 105 °C	5000 h
Useful life at 40 °C, 1.9 x I _R applied	125 000 h
Shelf life at 0 V, 105 °C	500 h
Based on sectional specification	IEC 60384-4 / EN 130300
Climatic category IEC 60068	40 / 105 / 56

FEATURES

- Useful life: 5000 h at +105 °C
- High ripple current capability
- Keyed polarity version available
- Polarized aluminum electrolytic capacitors, non-solid electrolyte
- Large types, very small dimensions, cylindrical aluminum case, insulated with a blue sleeve
- Material categorization: for definitions of compliance please see www.vishay.com/doc?99912

**RoHS
COMPLIANT**

APPLICATIONS

- General purpose, industrial telecommunication and audio / video systems
- Smoothing and filtering
- Standard and switched mode power supplies
- Energy storage in pulse systems

MARKING

The capacitors are marked (where possible) with the following information:

- Rated capacitance (in µF)
- Tolerance on rated capacitance, code letter in accordance with IEC 60062 (M for ± 20 %)
- Rated voltage (in V)
- Date code (YYMM)
- Name of manufacturer
- Code for factory of origin
- “-” sign to identify the negative terminal, visible from the top and side of the capacitor
- Code number
- Climatic category in accordance with IEC 60068

SELECTION CHART FOR C _R , U _R , AND RELEVANT NOMINAL CASE SIZES (Ø D x L in mm)							
C _R (µF)	U _R (V)						
	16	25	40	50	63	80	100
560	-	-	-	-	-	-	22 x 25
820	-	-	-	-	-	22 x 25	22 x 30
1000	-	-	-	-	-	-	22 x 35
	-	-	-	-	-	-	25 x 30
1200	-	-	-	-	22 x 25	22 x 30	25 x 35
	-	-	-	-	-	25 x 30	25 x 40
1500	-	-	-	-	-	25 x 35	-
	-	-	-	-	-	-	30 x 30

SELECTION CHART FOR C_R , U_R , AND RELEVANT NOMINAL CASE SIZES ($\varnothing D \times L$ in mm)							
C_R (μF)	U_R (V)						
	16	25	40	50	63	80	100
2200	-	-	22 x 25	22 x 30	22 x 35	25 x 40	30 x 35
	-	-	-	-	25 x 30	30 x 30	-
2700	-	-	-	22 x 35	-	-	30 x 40
	-	-	-	25 x 30	25 x 35	30 x 35	-
3300	-	22 x 25	22 x 30	-	25 x 40	25 x 50	30 x 50
	-	-	-	25 x 35	30 x 30	-	35 x 35
3900	-	-	22 x 35	22 x 45	-	30 x 40	35 x 40
	-	-	25 x 30	25 x 40	30 x 35	-	-
4700	-	22 x 30	22 x 40	-	30 x 40	35 x 35	35 x 50
	-	-	-	30 x 30	-	-	-
5600	22 x 25	-	-	25 x 50	-	35 x 40	-
	-	-	25 x 35	30 x 35	35 x 35	-	-
6800	-	22 x 35	-	30 x 40	30 x 50	35 x 50	-
	-	25 x 30	30 x 30	-	35 x 40	-	-
8200	22 x 30	22 x 40	25 x 50	-	35 x 45	-	-
	-	25 x 35	30 x 35	35 x 35	-	-	-
10 000	22 x 35	25 x 40	30 x 40	35 x 40	35 x 50	-	-
	25 x 30	30 x 30	35 x 30	-	-	-	-
12 000	22 x 40	-	-	35 x 45	-	-	-
	25 x 35	30 x 35	35 x 35	-	-	-	-
15 000	25 x 40	30 x 40	35 x 45	-	-	-	-
18 000	-	-	35 x 50	-	-	-	-
	30 x 35	35 x 35	-	-	-	-	-
22 000	30 x 40	30 x 50	-	-	-	-	-
27 000	-	35 x 45	-	-	-	-	-
	35 x 35	-	-	-	-	-	-
33 000	30 x 50	35 x 50	-	-	-	-	-
	35 x 40	-	-	-	-	-	-
39 000	35 x 45	-	-	-	-	-	-
47 000	35 x 50	-	-	-	-	-	-

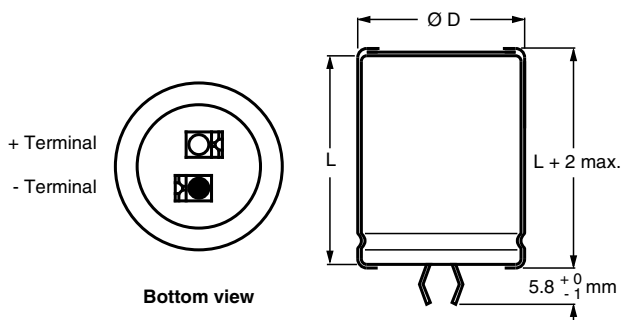
DIMENSIONS in millimeters AND AVAILABLE FORMS
TWO TERMINAL SNAP-IN

The minus terminal can be marked with a black dot or with an imprinted “-” sign.

Fig. 2 - Two terminal snap-in

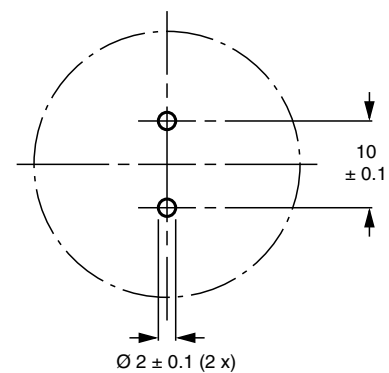
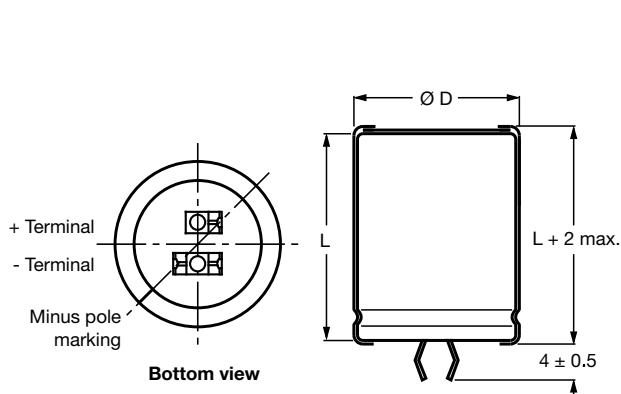
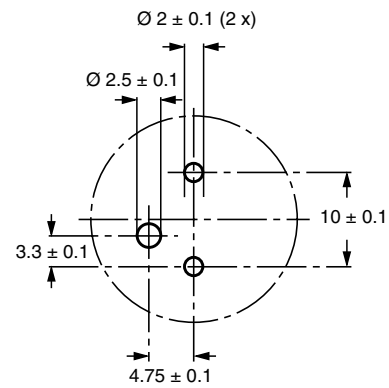

Fig. 3 - Mounting hole diagram

THREE TERMINAL SNAP-IN

The negative terminal has **TWO** pins which are **BOTH** electrically connected.

Fig. 4 - Three terminal snap-in



The 10 mm spacing of the 2 pin snap-in is used as the base layout and a third hole is added. The third hole is closer to the negative primary hole so that polarization is always maintained, together with added mechanical stability.

Fig. 5 - Mounting hole diagram

Table 1

DIMENSIONS in millimeters, MASS AND PACKAGING QUANTITIES					
NOMINAL CASE SIZE Ø D x L	Ø D _{max.}	L _{max.}	MASS (g)	PACKAGING QUANTITIES (units per box)	CARDBOARD BOX DIMENSIONS L x W x H
22 x 25	23	27	≈ 12	100	260 x 250 x 39
22 x 30	23	32	≈ 16	100	260 x 250 x 44
22 x 35	23	37	≈ 20	100	260 x 250 x 49
22 x 40	23	42	≈ 23	100	260 x 250 x 54
25 x 30	26	32	≈ 22	100	290 x 280 x 44
25 x 35	26	37	≈ 24	100	290 x 280 x 49
25 x 40	26	42	≈ 27	100	290 x 280 x 54
25 x 50	26	52	≈ 38	100	290 x 280 x 64
30 x 30	31	32	≈ 30	100	340 x 330 x 44
30 x 35	31	37	≈ 35	100	340 x 330 x 49
30 x 40	31	42	≈ 40	100	340 x 330 x 54
30 x 50	31	52	≈ 50	100	340 x 330 x 64
35 x 35	36	37	≈ 48	50	390 x 198 x 49
35 x 40	36	42	≈ 55	50	390 x 198 x 54
35 x 45	36	47	≈ 63	50	390 x 198 x 59
35 x 50	36	52	≈ 72	50	390 x 198 x 64



ELECTRICAL DATA	
SYMBOL	DESCRIPTION
C_R	Rated capacitance at 100 Hz
I_R	Rated RMS ripple current at 100 Hz, 105 °C
I_{L5}	Max. leakage current after 5 min at U_R
ESR	Typ. / max. equivalent series resistance at 100 Hz ⁽¹⁾
Z	Typ. / max. impedance at 10 kHz

Notes

- ⁽¹⁾ ESR at 120 Hz is approximately 0.95 x ESR 100 Hz
- Unless otherwise specified, all electrical values in Table 2 apply at $T_{amb} = 20\text{ °C}$, $P = 86\text{ kPa}$ to 106 kPa , $RH = 45\text{ \%}$ to 75 \%

ORDERING EXAMPLE

Electrolytic capacitor 158 series
 3900 μF / 80 V; $\pm 20\text{ \%}$
 Nominal case size: $\varnothing 30\text{ mm} \times 40\text{ mm}$

2-terminal snap-in:

Ordering code: MAL2 158 32392 E3
 Former 12NC: 2222 158 32392

3-terminal snap-in:

Ordering code: MAL2 158 72392 E3
 Former 12NC: 2222 158 72392

Table 2

ELECTRICAL DATA AND ORDERING INFORMATION									
U_R (V)	C_R 100 Hz (μF)	NOMINAL CASE SIZE $\varnothing D \times L$ (mm)	I_R 100 Hz 105 °C (A)	I_R 10 kHz 105 °C (A)	I_{L5} 5 min (mA)	MAX. ESR 100 Hz ⁽¹⁾ (m Ω)	MAX. Z 10 kHz (m Ω)	ORDERING CODE MAL2158.....	
								2-TERM.	3-TERM.
16	5600	22 x 25	2.50	2.95	0.18	111	98	15562E3	55562E3
	8200	22 x 30	3.10	3.66	0.27	79	70	15822E3	55822E3
	10 000	22 x 35	3.56	4.20	0.32	65	58	15103E3	55103E3
	10 000	25 x 30	3.42	4.04	0.32	70	63	25103E3	65103E3
	12 000	22 x 40	4.00	4.72	0.39	56	50	15123E3	55123E3
	12 000	25 x 35	3.91	4.61	0.39	59	53	25123E3	65123E3
	15 000	25 x 40	4.39	5.18	0.48	49	45	25153E3	65153E3
	15 000	30 x 30	3.80	4.48	0.48	61	55	35153E3	75153E3
	18 000	30 x 35	4.36	5.14	0.58	50	46	35183E3	75183E3
	22 000	30 x 40	4.85	5.72	0.71	43	39	35223E3	75223E3
	27 000	35 x 35	4.49	5.30	0.87	49	43	45273E3	85273E3
	33 000	30 x 50	5.70	6.73	1.06	33	31	35333E3	75333E3
	33 000	35 x 40	4.97	5.86	1.06	42	37	45333E3	85333E3
	39 000	35 x 45	5.42	6.40	1.25	37	33	45393E3	85393E3
47 000	35 x 50	5.80	6.84	1.51	33	30	45473E3	85473E3	
25	3300	22 x 25	2.27	2.68	0.17	130	105	16332E3	56332E3
	4700	22 x 30	2.82	3.33	0.24	93	76	16472E3	56472E3
	6800	22 x 35	3.37	3.98	0.34	69	57	16682E3	56682E3
	6800	25 x 30	3.25	3.84	0.34	74	62	26682E3	66682E3
	8200	22 x 40	3.79	4.47	0.41	58	49	16822E3	56822E3
	8200	25 x 35	3.72	4.39	0.41	62	52	26822E3	66822E3
	10 000	25 x 40	4.18	4.93	0.50	52	44	26103E3	66103E3
	10 000	30 x 30	3.65	4.31	0.50	64	55	36103E3	76103E3
	12 000	30 x 35	4.19	4.94	0.60	53	46	36123E3	76123E3
	15 000	30 x 40	4.66	5.50	0.75	45	39	36153E3	76153E3
	18 000	35 x 35	4.36	5.14	0.90	51	43	46183E3	86183E3
	22 000	30 x 50	5.52	6.51	1.10	35	31	36223E3	76223E3
	22 000	35 x 40	4.83	5.70	1.10	44	37	46223E3	86223E3
	27 000	35 x 45	5.24	6.18	1.35	39	33	46273E3	86273E3
	33 000	35 x 50	5.32	6.27	1.65	36	31	46333E3	86333E3



ELECTRICAL DATA AND ORDERING INFORMATION									
U _R (V)	C _R 100 Hz (μF)	NOMINAL CASE SIZE Ø D x L (mm)	I _R 100 Hz 105 °C (A)	I _R 10 kHz 105 °C (A)	I _{L5} 5 min (mA)	MAX. ESR 100 Hz ⁽¹⁾ (mΩ)	MAX. Z 10 kHz (mΩ)	ORDERING CODE MAL2158.....	
								2-TERM.	3-TERM.
40	2200	22 x 25	2.17	2.65	0.18	131	100	17222E3	57222E3
	3300	22 x 30	2.73	3.33	0.27	91	70	17332E3	57332E3
	3900	22 x 35	3.12	3.81	0.32	77	59	17392E3	57392E3
	3900	25 x 30	3.02	3.68	0.32	83	65	27392E3	67392E3
	4700	22 x 40	3.52	4.29	0.38	65	51	17472E3	57472E3
	5600	25 x 35	3.53	4.31	0.45	63	51	27562E3	67562E3
	6800	30 x 30	3.39	4.14	0.55	69	56	37682E3	77682E3
	8200	25 x 50	4.72	5.76	0.66	44	36	27822E3	67822E3
	8200	30 x 35	3.90	4.76	0.66	57	47	37822E3	77822E3
	10 000	30 x 40	4.36	5.32	0.80	48	40	37103E3	77103E3
	12 000	35 x 35	4.00	4.88	0.96	56	45	47123E3	87123E3
	15 000	35 x 45	4.99	6.09	1.20	42	35	47153E3	87153E3
18 000	35 x 50	5.36	6.54	1.44	38	31	47183E3	87183E3	
50	1500	22 x 25	1.99	2.43	0.15	148	102	11152E3	51152E3
	2200	22 x 30	2.50	3.05	0.22	104	73	11222E3	51222E3
	2700	22 x 35	2.88	3.51	0.27	85	60	11272E3	51272E3
	2700	25 x 30	2.81	3.43	0.27	91	66	21272E3	61272E3
	3300	22 x 40	3.27	3.99	0.33	71	51	11332E3	51332E3
	3300	25 x 35	3.23	3.94	0.33	75	55	21332E3	61332E3
	3900	25 x 40	3.62	4.42	0.39	64	47	21392E3	61392E3
	4700	30 x 30	3.24	3.95	0.47	74	57	31472E3	71472E3
	5600	25 x 50	4.43	5.40	0.56	48	36	21562E3	61562E3
	5600	30 x 35	3.73	4.55	0.56	61	47	31562E3	71562E3
	6800	30 x 40	4.17	5.09	0.68	52	41	31682E3	71682E3
	8200	35 x 35	3.88	4.73	0.82	61	46	41822E3	81822E3
	10 000	35 x 40	4.33	5.28	1.00	52	40	41103E3	81103E3
12 000	35 x 45	4.72	5.76	1.20	46	35	41123E3	81123E3	
63	1200	22 x 25	2.07	2.53	0.16	137	100	18122E3	58122E3
	1500	22 x 30	2.49	3.04	0.19	107	78	18152E3	58152E3
	2200	22 x 35	3.00	3.66	0.26	79	58	18222E3	58222E3
	2200	25 x 30	2.90	3.54	0.28	85	64	28222E3	68222E3
	2700	25 x 35	3.34	4.07	0.34	70	53	28272E3	68272E3
	3300	25 x 40	3.76	4.59	0.42	59	45	28332E3	68332E3
	3300	30 x 30	3.28	4.00	0.42	74	58	38332E3	78332E3
	3900	30 x 35	3.77	4.60	0.50	61	48	38392E3	78392E3
	4700	30 x 40	4.22	5.15	0.60	52	41	38472E3	78472E3
	5600	35 x 35	3.97	4.84	0.71	59	47	48562E3	88562E3
	6800	30 x 50	5.04	6.15	0.86	40	33	38682E3	78682E3
	6800	35 x 40	4.42	5.39	0.86	51	40	48682E3	88682E3
	8200	35 x 45	4.82	5.88	1.04	45	35	48822E3	88822E3
10 000	35 x 50	5.17	6.31	1.26	40	32	48103E3	88103E3	



ELECTRICAL DATA AND ORDERING INFORMATION									
U _R (V)	C _R 100 Hz (μF)	NOMINAL CASE SIZE Ø D x L (mm)	I _R 100 Hz 105 °C (A)	I _R 10 kHz 105 °C (A)	I _{L5} 5 min (mA)	MAX. ESR 100 Hz ⁽¹⁾ (mΩ)	MAX. Z 10 kHz (mΩ)	ORDERING CODE MAL2158.....	
								2-TERM.	3-TERM.
80	820	22 x 25	1.44	1.76	0.14	422	397	12821E3	52821E3
	1200	22 x 30	1.82	2.22	0.20	291	274	12122E3	52122E3
	1500	22 x 35	2.12	2.59	0.24	234	221	12152E3	52152E3
	1500	25 x 30	2.10	2.56	0.24	240	228	22152E3	62152E3
	1800	25 x 35	2.41	2.94	0.29	201	189	22182E3	62182E3
	2200	25 x 40	2.74	3.34	0.36	166	156	22222E3	62222E3
	2200	30 x 30	2.55	3.11	0.36	180	172	32222E3	72222E3
	2700	30 x 35	2.93	3.57	0.44	147	141	32272E3	72272E3
	3300	25 x 50	3.46	4.22	0.53	114	109	22332E3	62332E3
	3900	30 x 40	3.39	4.14	0.63	110	106	32392E3	72392E3
	4700	35 x 35	3.29	4.01	0.76	110	107	42472E3	82472E3
	5600	35 x 40	3.69	4.50	0.90	93	90	42562E3	82562E3
6800	35 x 50	4.43	5.40	1.09	75	71	42682E3	82682E3	
100	560	22 x 25	1.33	1.62	0.12	461	412	19561E3	59561E3
	820	22 x 30	1.69	2.06	0.17	318	284	19821E3	59821E3
	1000	22 x 35	1.95	2.38	0.20	261	234	19102E3	59102E3
	1000	25 x 30	1.95	2.38	0.20	267	240	29102E3	69102E3
	1200	25 x 35	2.23	2.72	0.24	223	200	29122E3	69122E3
	1500	25 x 40	2.56	3.12	0.30	180	162	29152E3	69152E3
	1800	30 x 30	2.49	3.04	0.36	172	158	39182E3	79182E3
	2200	30 x 35	2.87	3.50	0.44	141	129	39222E3	79222E3
	2700	30 x 40	3.24	3.95	0.54	117	108	39272E3	79272E3
	3300	30 x 50	3.87	4.72	0.66	94	87	39332E3	79332E3
	3300	35 x 35	3.19	3.89	0.66	115	107	49332E3	89332E3
	3900	35 x 40	3.58	4.37	0.78	98	91	49392E3	89392E3
4700	35 x 50	4.29	5.23	0.94	78	73	49472E3	89472E3	

ADDITIONAL ELECTRICAL DATA		
PARAMETER	CONDITIONS	VALUE
Voltage		
Surge voltage		$U_s = 1.15 \times U_R$
Reverse voltage		$U_{rev} \leq 1 V$
Current		
Leakage current	After 1 min at U _R	$I_{L1} \leq 0.006 C_R \times U_R + 4 \mu A$
	After 5 min at U _R	$I_{L5} \leq 0.002 C_R \times U_R + 4 \mu A$
Inductance		
Equivalent series inductance (ESL)	All case sizes	Typ. 19 nH
		Max. 25 nH

RIPPLE CURRENT AND USEFUL LIFE

Table 3

ENDURANCE TEST DURATION AND USEFUL LIFE	
ENDURANCE AT 105 °C (h)	USEFUL LIFE AT 105 °C (h)
2000	5000

Note

- Multiplier of useful life code: MGA454

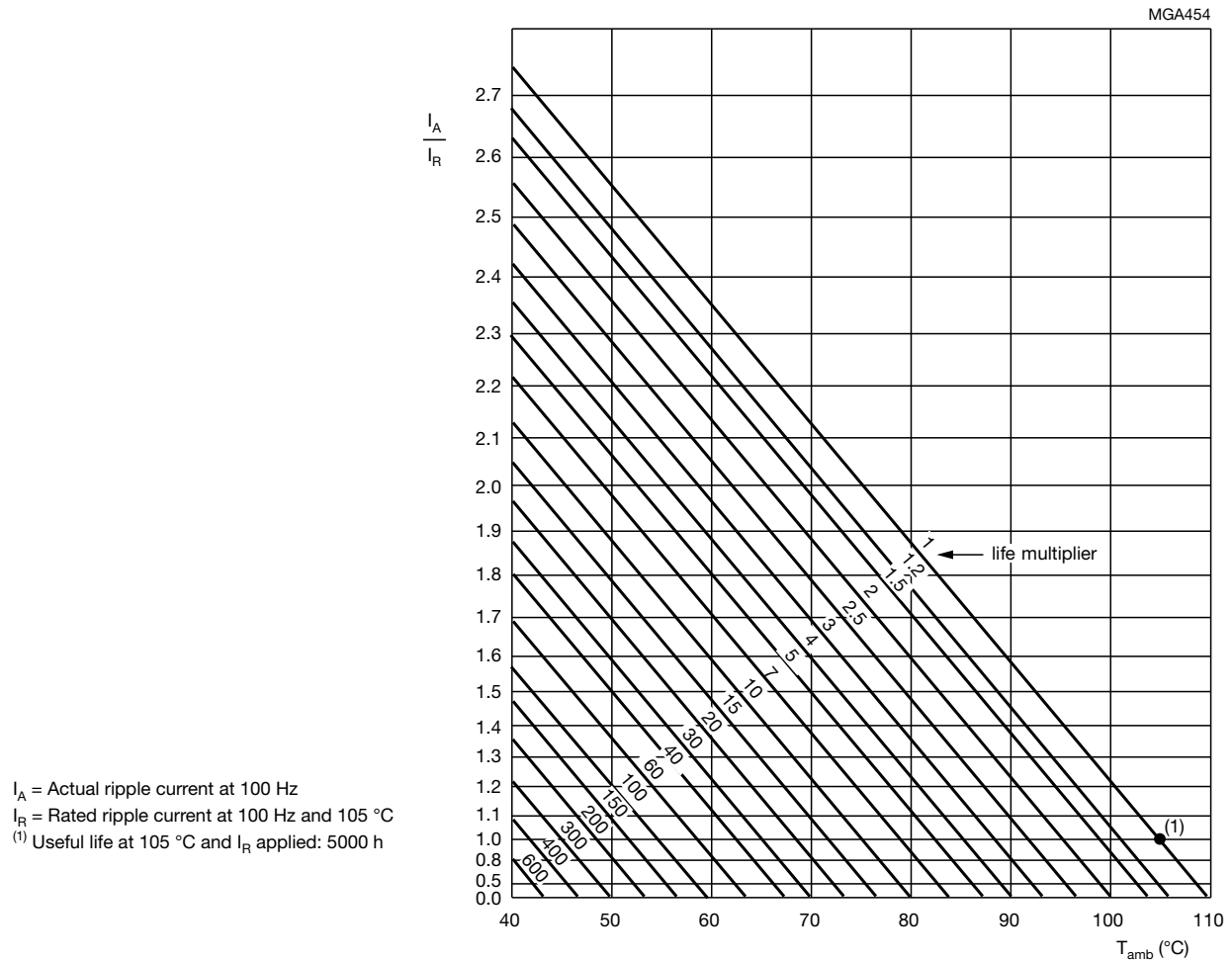

Fig. 6 - Multiplier of useful life as a function of ambient temperature and ripple current load

Table 4

MULTIPLIER OF RIPPLE CURRENT (I_R) AS A FUNCTION OF FREQUENCY								
U_R (V)	FREQUENCY (Hz)							
	50	100	200	400	1000	2000	4000	$\geq 10\ 000$
	I_R MULTIPLIER							
16	0.93	1.00	1.04	1.07	1.11	1.13	1.15	1.18
25	0.93	1.00	1.04	1.07	1.11	1.13	1.15	1.18
40	0.91	1.00	1.05	1.09	1.13	1.15	1.18	1.22
50	0.91	1.00	1.05	1.09	1.13	1.15	1.18	1.22
63	0.91	1.00	1.05	1.09	1.13	1.15	1.18	1.22
80	0.91	1.00	1.05	1.09	1.13	1.15	1.18	1.22
100	0.91	1.00	1.05	1.09	1.13	1.15	1.18	1.22



Table 5

TEST PROCEDURES AND REQUIREMENTS			
TEST		PROCEDURE (quick reference)	REQUIREMENTS
NAME OF TEST	REFERENCE		
Endurance	IEC 60384-4 / EN130300 subclause 4.13	T _{amb} = 105 °C; U _R applied; 2000 h	ΔC/C: ± 15 % ESR ≤ 1.3 x spec. limit Z ≤ 2 x spec. limit I _{L5} ≤ spec. limit
Useful life	CECC 30301 subclause 1.8.1	T _{amb} = 105 °C; U _R and I _R applied; 5000 h	ΔC/C: ± 20 % ESR ≤ 3 x spec. limit Z ≤ 3 x spec. limit I _{L5} ≤ spec. limit no short or open circuit, no visible damage total failure percentage: U _R : ≤ 1 %
Shelf life (storage at high temperature)	IEC 60384-4 / EN130300 subclause 4.17	T _{amb} = 105 °C; no voltage applied; 500 h After test: U _R to be applied for 30 min, 24 h to 48 h before measurement	ΔC/C: ± 15 % ESR ≤ 1.5 x spec. limit I _{L5} ≤ 2 x spec. limit

Statements about product lifetime are based on calculations and internal testing. They should only be interpreted as estimations. Also due to external factors, the lifetime in the field application may deviate from the calculated lifetime. In general, nothing stated herein shall be construed as a guarantee of durability.



Disclaimer

ALL PRODUCT, PRODUCT SPECIFICATIONS AND DATA ARE SUBJECT TO CHANGE WITHOUT NOTICE TO IMPROVE RELIABILITY, FUNCTION OR DESIGN OR OTHERWISE.

Vishay Intertechnology, Inc., its affiliates, agents, and employees, and all persons acting on its or their behalf (collectively, "Vishay"), disclaim any and all liability for any errors, inaccuracies or incompleteness contained in any datasheet or in any other disclosure relating to any product.

Vishay makes no warranty, representation or guarantee regarding the suitability of the products for any particular purpose or the continuing production of any product. To the maximum extent permitted by applicable law, Vishay disclaims (i) any and all liability arising out of the application or use of any product, (ii) any and all liability, including without limitation special, consequential or incidental damages, and (iii) any and all implied warranties, including warranties of fitness for particular purpose, non-infringement and merchantability.

Statements regarding the suitability of products for certain types of applications are based on Vishay's knowledge of typical requirements that are often placed on Vishay products in generic applications. Such statements are not binding statements about the suitability of products for a particular application. It is the customer's responsibility to validate that a particular product with the properties described in the product specification is suitable for use in a particular application. Parameters provided in datasheets and / or specifications may vary in different applications and performance may vary over time. All operating parameters, including typical parameters, must be validated for each customer application by the customer's technical experts. Product specifications do not expand or otherwise modify Vishay's terms and conditions of purchase, including but not limited to the warranty expressed therein.

Hyperlinks included in this datasheet may direct users to third-party websites. These links are provided as a convenience and for informational purposes only. Inclusion of these hyperlinks does not constitute an endorsement or an approval by Vishay of any of the products, services or opinions of the corporation, organization or individual associated with the third-party website. Vishay disclaims any and all liability and bears no responsibility for the accuracy, legality or content of the third-party website or for that of subsequent links.

Vishay products are not designed for use in life-saving or life-sustaining applications or any application in which the failure of the Vishay product could result in personal injury or death unless specifically qualified in writing by Vishay. Customers using or selling Vishay products not expressly indicated for use in such applications do so at their own risk. Please contact authorized Vishay personnel to obtain written terms and conditions regarding products designed for such applications.

No license, express or implied, by estoppel or otherwise, to any intellectual property rights is granted by this document or by any conduct of Vishay. Product names and markings noted herein may be trademarks of their respective owners.