



PUI audio



| | |
|------------|---------------|
| Data Sheet | AS05008PR-A-R |
|------------|---------------|

Specifications

| Parameters | Values | Units |
|--|---|-------|
| Rated Input Power | 1.0 | Watts |
| Max Input Power | 2.0 | Watts |
| Impedance | $8 \pm 15\%$ | Ohms |
| Output SPL @ 1W/1M <i>(AVG. 0.8, 1.0, 1.2, 1.5 kHz)</i> | 84 ± 3 | dB |
| Output SPL @ 1W/10cm <i>(AVG. 0.8, 1.0, 1.2, 1.5 kHz)</i> | 94 ± 3 | |
| Resonant Frequency (Fo) | $540 \pm 20\%$ | Hz |
| Frequency Range | Fo ~ 4,500 | Hz |
| THD (1kHz, 0.5W) | 5% Max | - |
| Frame Material | Metal | - |
| Magnet Material | NdFeB | - |
| Diaphragm Material | Paper | - |
| Weight | 16.2g | Grams |
| Buzz, Rattle, etc. | Must be normal at sine wave between Fo-7,500Hz | - |
| Environmental Compliances | ROHS/REACH | - |
| Polarity | When a positive DC Current is applied to the voice coil terminal marked +or red ,the diaphragm shall move forward | - |
| Storage Temperature | -30 ~ 70 | °C |
| Operating Temperature | -20 ~ 60 | °C |

Measurement Method (L=10cm, Power=2.83Vrms)

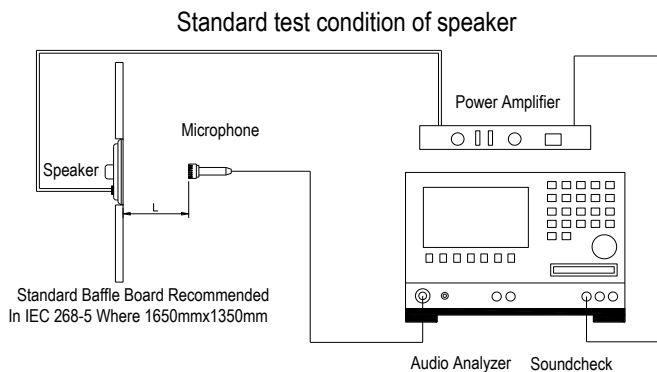

Typical Frequency Response

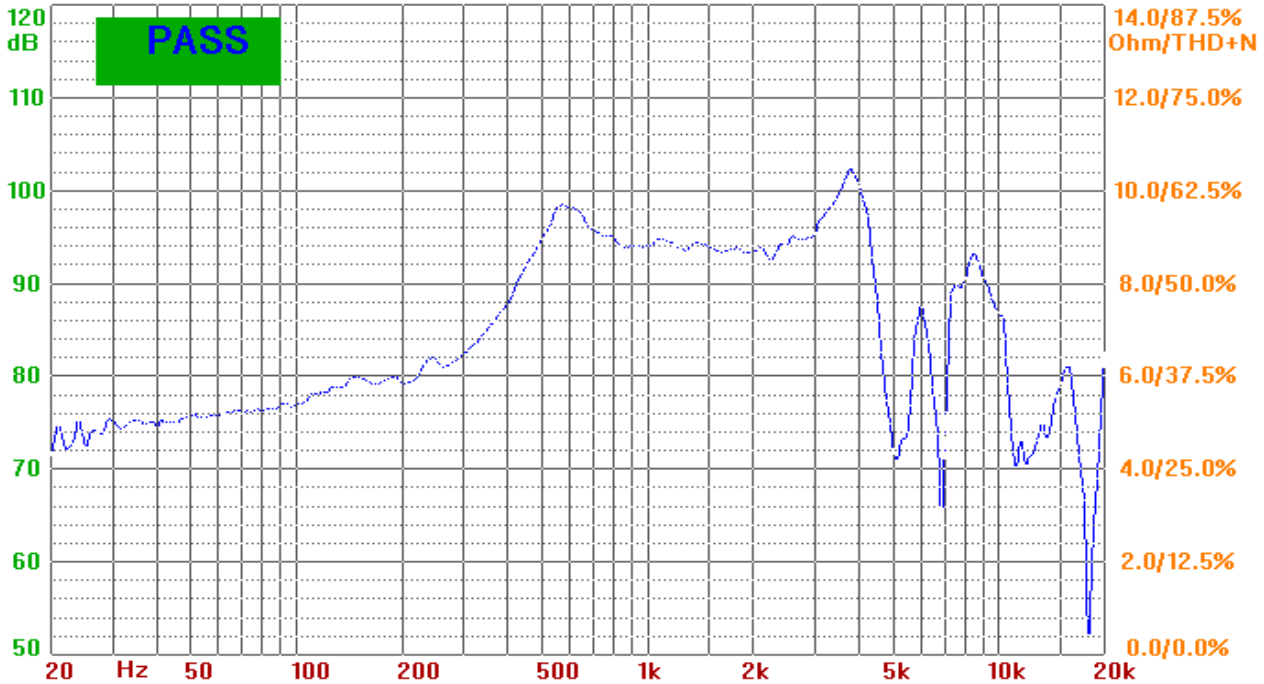

Reliability Testing

| Type of Test | Test Specifications |
|---------------------------|---|
| High Temperature Test | 96 hours at 70°C |
| Low Temperature Test | 96 hours at -30°C |
| Humidity Test | 96 hours at 30°C with relative humidity at 92~95% |
| Temperature Cycle Testing | Subject each part to 5 cycles, with each cycle consisting of: |
| Vibration Test | Speaker shall be measured after being applied vibration of amplitude of 1.5mm with 10-55-10Hz band of vibration frequency in 3 perpendicular directions for 2 hours each. |
| Drop Test | Drop the speakers contained in normal box onto the board 40mm thick 10times from the height of 75cm |
| Load Test | White noise at rated power is applied for 96 hours |

After each test, let rest for 6 hours in 25°C, and then each part should be within ±3dB.

Dimensions

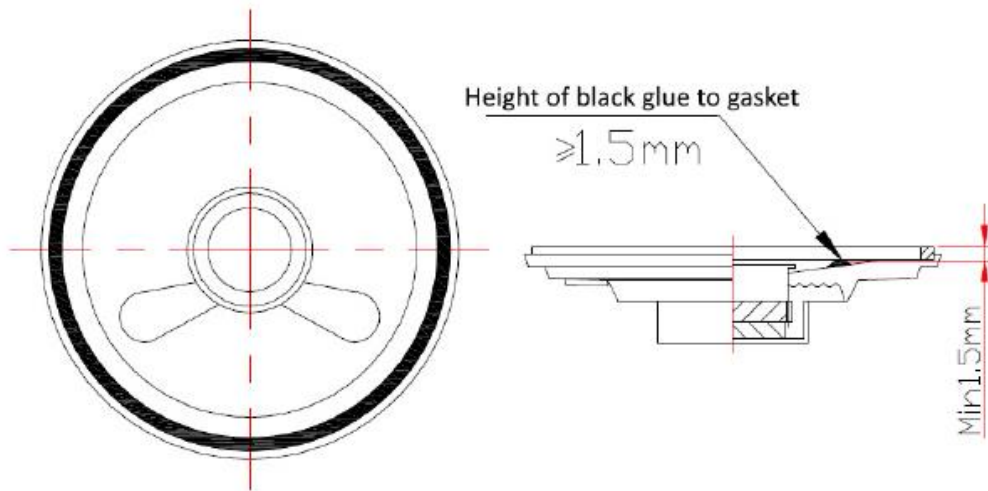
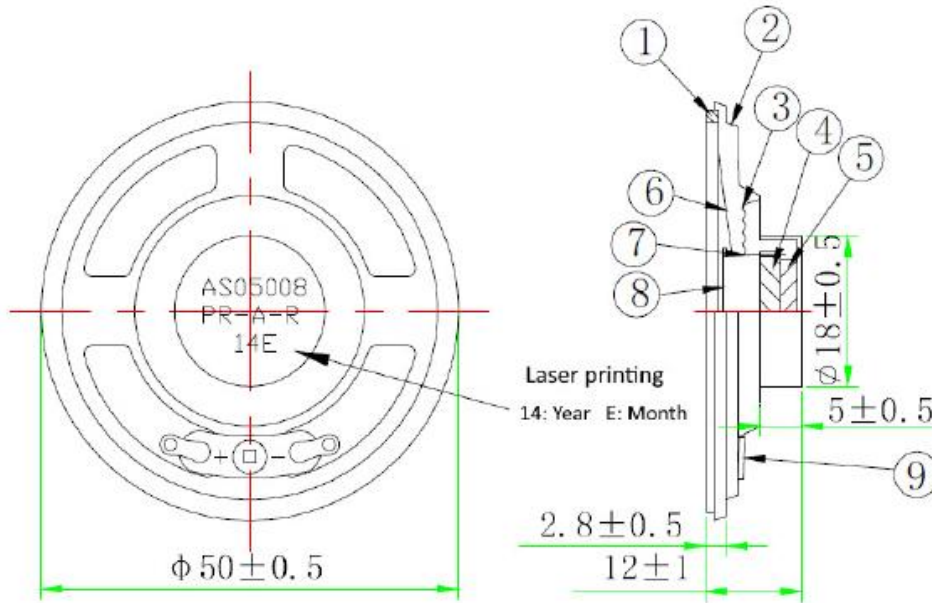

| PART NO. | PART NAME | Q'TY | MATERIAL | REMARK |
|----------|-------------|------|--------------|-----------|
| 1 | Gasket | 1 | Paper | |
| 2 | Frame | 1 | SPCC | |
| 3 | Damper | 1 | Cloth | |
| 4 | Plate | 1 | SPCC | |
| 5 | Magnet | 1 | NdFeB | |
| 6 | Cone | 1 | Paper | |
| 7 | Voice coil | 1 | PL+Cu | |
| 8 | Dust cap | 1 | Paper | |
| 9 | Terminals | 1 | Paper+steel | |
| 10 | Tinsel lead | 2 | Braided wire | 3 strands |

Packaging

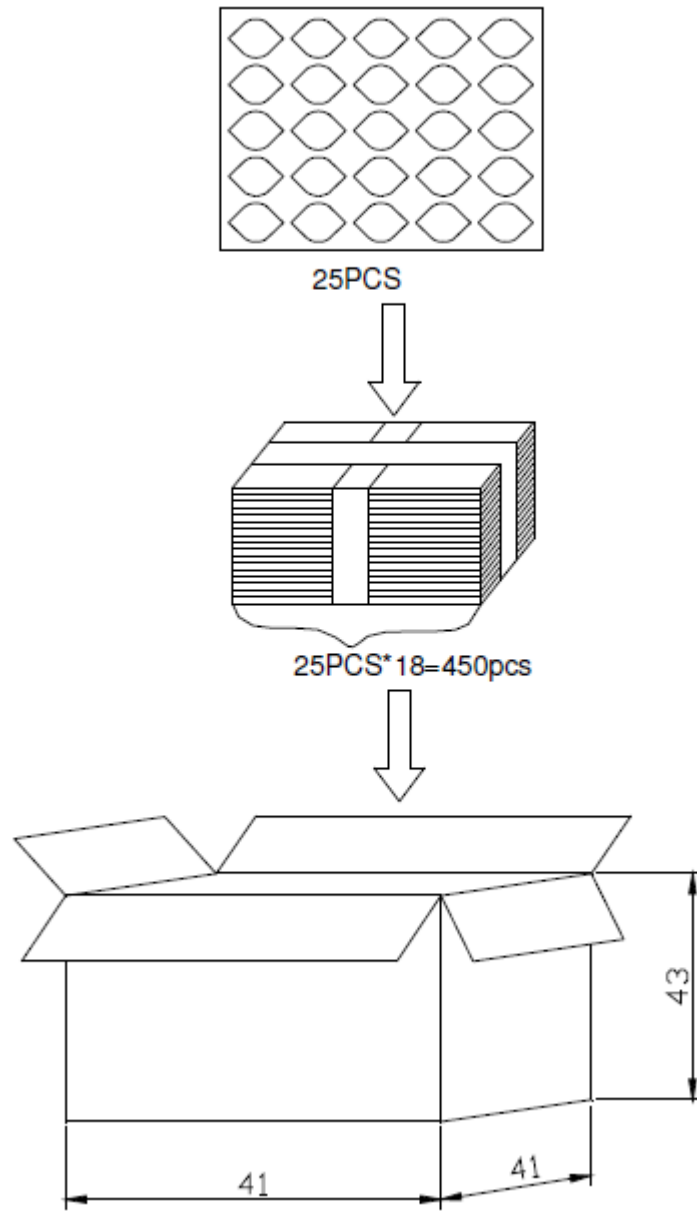

Specifications Revisions

| Revision | Description | Date | Approved |
|----------|---|------------|----------|
| - | Released from Engineering | 09/25/2006 | - |
| A | Revised to Inventor 3D Drawing Template | 05/24/2010 | B.R. |
| B | Change Voice Coil Wire to Braided Wire Type | 03/23/2015 | B.R. |
| C | Update Spec Format, Adjust Max Power, Resonant Frequency, and Operating Temperature, Update Drawing | 06/12/2024 | M.L. |

Note:

1. Unless otherwise specified:
 - A. All dimensions are in millimeters.
 - B. Default tolerances are $\pm 0.5\text{mm}$ and angles are $\pm 3^\circ$.
2. Specifications subject to change or withdrawal without notice.