

Features

- Fully Automotive Qualified to AEC-Q101
- For Surface Mount Applications
- Excellent Clamping Capability
- High Temp Soldering: 260°C / 10 Seconds At Terminals
- Halogen Free. "Green" Device (Note 1)
- Moisture Sensitivity Level 1
- Epoxy Meets UL 94 V-0 Flammability Rating
- Lead Free Finish/RoHS Compliant (Note2) ("P" Suffix Designates RoHS Compliant. See Ordering Information)
- ESD protection of data lines in accordance with IEC 61000-4-2, 30kV(Air), 30kV (Contact)

Maximum Ratings

Parameter	Symbol	Value	Unit
Peak Pulse Power Surge Current with a 10/1000µs Waveform (Note 3)	I_{PPM}	See Next Table	A
Peak Pulse Power Dissipation (Note 3)	P_{PPM}	200	W
Power Dissipation on Infinite Heatsink at $T_A = 55^\circ\text{C}$	P_D	0.4	W
Peak Forward Surge Current Unidirectional Only (Note 4)	I_{FSM}	20	A

Note:

1. Halogen free "Green" products are defined as those which contain <900ppm bromine, <900ppm chlorine (<1500ppm total Br + Cl) and <1000ppm antimony compounds.
2. High Temperature Solder Exemption Applied, see EU Directive Annex 7a.
3. Non-repetitive current pulse, per Fig.3 and derated above $T_A = 25^\circ\text{C}$ per Fig.4.
4. 8.3ms, single half sine wave duty cycle = 4 pulses per Minutes maximum.

Internal Structure and Marking Code

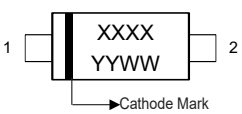
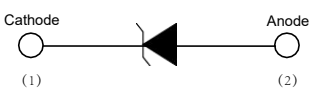
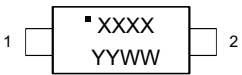
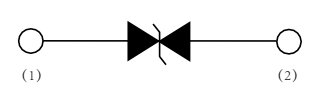
Description	Simplified outline	Graphic symbol
Uni-directional		
Bi-directional		

XXXX = Marking code YYWW = Date Code

200Watt TVS 5.0 to 100 Volts

SOD-123FL

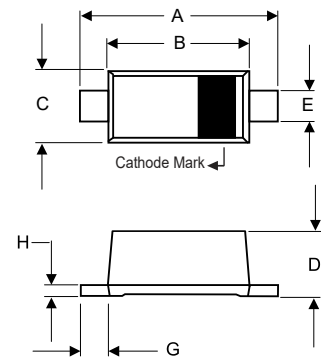

DIMENSIONS

DIM	INCHES		MM		NOTE
	MIN	MAX	MIN	MAX	
A	0.130	0.152	3.30	3.85	
B	0.100	0.122	2.55	3.10	
C	0.055	0.075	1.40	1.90	
D	0.035	0.053	0.90	1.35	
E	0.020	0.041	0.50	1.05	
G	0.010	----	0.25	----	
H	----	0.010	----	0.25	

SUGGESTED SOLDER PAD LAYOUT

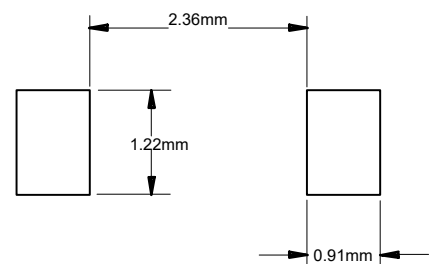

Thermal Characteristics

Parameter	Symbol	Value	Unit
Operating Junction Temperature Range	T_J	-55 to +175	°C
Storage Temperature Range	T_{STG}	-55 to +175	°C
Typical Thermal Resistance Junction to Lead	$R_{\theta JL}$	26	°C/W
Typical Thermal Resistance Junction to Ambient	$R_{\theta JA}$	300	°C/W
Typical Thermal Resistance Junction to Case	$R_{\theta JC}$	40	°C/W

MCC Part Number		Working Peak Reverse Voltage	Breakdown Voltage $V_{BR} @ I_T$			Maximum Clamping Voltage @ I_{PP}	Maximum Reverse Surge Current	Maximum Reverse Leakage @ V_{RWM}	Device Marking Code	
(Uni)	(Bi)	$V_{RWM}(V)$	Min (V)	Max (V)	$I_T (mA)$	$V_C(V)$	$I_{PP}(A)$	$I_R(\mu A)$	Uni	Bi
SMF5.0AQ	SMF5.0CAQ	5.0	6.40	7.07	10	9.2	21.74	400.0	5.0A	5.0CA
SMF6.0AQ	SMF6.0CAQ	6.0	6.67	7.37	10	10.3	19.42	400.0	6.0A	6.0CA
SMF6.5AQ	SMF6.5CAQ	6.5	7.22	7.98	10	11.2	17.86	250.0	6.5A	6.5CA
SMF7.0AQ	SMF7.0CAQ	7.0	7.78	8.60	10	12.0	16.67	100.0	7.0A	7.0CA
SMF7.5AQ	SMF7.5CAQ	7.5	8.33	9.21	1	12.9	15.50	50.0	7.5A	7.5CA
SMF8.0AQ	SMF8.0CAQ	8.0	8.89	9.83	1	13.6	14.71	25.0	8.0A	8.0CA
SMF8.5AQ	SMF8.5CAQ	8.5	9.44	10.40	1	14.4	13.89	10.0	8.5A	8.5CA
SMF9.0AQ	SMF9.0CAQ	9.0	10.00	11.10	1	15.4	12.99	5.0	9.0A	9.0CA
SMF10AQ	SMF10CAQ	10.0	11.10	12.30	1	17.0	11.76	2.5	10A	10CA
SMF11AQ	SMF11CAQ	11.0	12.20	13.50	1	18.2	10.99	2.5	11A	11CA
SMF12AQ	SMF12CAQ	12.0	13.30	14.70	1	19.9	10.05	2.5	12A	12CA
SMF13AQ	SMF13CAQ	13.0	14.40	15.90	1	21.5	9.30	1.0	13A	13CA
SMF14AQ	SMF14CAQ	14.0	15.60	17.20	1	23.2	8.62	1.0	14A	14CA
SMF15AQ	SMF15CAQ	15.0	16.70	18.50	1	24.4	8.20	1.0	15A	15CA
SMF16AQ	SMF16CAQ	16.0	17.80	19.70	1	26.0	7.69	1.0	16A	16CA
SMF17AQ	SMF17CAQ	17.0	18.90	20.90	1	27.6	7.25	1.0	17A	17CA
SMF18AQ	SMF18CAQ	18.0	20.00	22.10	1	29.2	6.85	1.0	18A	18CA
SMF19AQ	SMF19CAQ	19.0	21.10	23.30	1	30.6	6.54	1.0	19A	19CA
SMF20AQ	SMF20CAQ	20.0	22.20	24.50	1	32.4	6.17	1.0	20A	20CA
SMF22AQ	SMF22CAQ	22.0	24.40	26.90	1	35.5	5.63	1.0	22A	22CA
SMF24AQ	SMF24CAQ	24.0	26.70	29.50	1	38.9	5.14	1.0	24A	24CA
SMF26AQ	SMF26CAQ	26.0	28.90	31.90	1	42.1	4.75	1.0	26A	26CA
SMF28AQ	SMF28CAQ	28.0	31.10	34.40	1	45.4	4.41	1.0	28A	28CA
SMF30AQ	SMF30CAQ	30.0	33.30	36.80	1	48.4	4.13	1.0	30A	30CA
SMF33AQ	SMF33CAQ	33.0	36.70	40.60	1	53.3	3.75	1.0	33A	33CA
SMF36AQ	SMF36CAQ	36.0	40.00	44.20	1	58.1	3.44	1.0	36A	36CA
SMF40AQ	SMF40CAQ	40.0	44.40	49.10	1	64.5	3.10	1.0	40A	40CA
SMF43AQ	SMF43CAQ	43.0	47.80	52.80	1	69.4	2.88	1.0	43A	43CA
SMF45AQ	SMF45CAQ	45.0	50.00	55.30	1	72.7	2.75	1.0	45A	45CA
SMF48AQ	SMF48CAQ	48.0	53.30	58.90	1	77.4	2.58	1.0	48A	48CA
SMF51AQ	SMF51CAQ	51.0	56.70	62.70	1	82.4	2.43	1.0	51A	51CA
SMF54AQ	SMF54CAQ	54.0	60.00	66.30	1	87.1	2.30	1.0	54A	54CA
SMF58AQ	SMF58CAQ	58.0	64.40	71.20	1	93.6	2.14	1.0	58A	58CA
SMF60AQ	SMF60CAQ	60.0	66.70	73.70	1	96.8	2.07	1.0	60A	60CA
SMF64AQ	SMF64CAQ	64.0	71.10	78.60	1	103.0	1.94	1.0	64A	64CA
SMF70AQ	SMF70CAQ	70.0	77.80	86.00	1	113.0	1.77	1.0	70A	70CA
SMF75AQ	SMF75CAQ	75.0	83.30	92.10	1	121.0	1.65	1.0	75A	75CA
SMF78AQ	SMF78CAQ	78.0	86.70	95.80	1	126.0	1.59	1.0	78A	78CA
SMF80AQ	SMF80CAQ	80.0	88.80	97.60	1	129.0	1.55	1.0	80A	80CA
SMF85AQ	SMF85CAQ	85.0	94.40	104.00	1	137.0	1.46	1.0	85A	85CA
SMF90AQ	SMF90CAQ	90.0	100.00	111.00	1	146.0	1.37	1.0	90A	90CA
SMF100AQ	SMF100CAQ	100.0	111.00	123.00	1	162.0	1.23	1.0	100	100C

Curve Characteristics

Fig. 1 - Peak Pulse Power Rating Curve

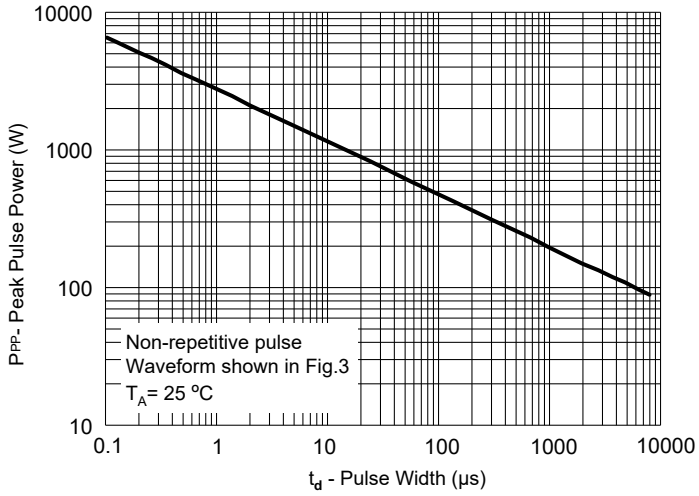

Fig. 2 - Typical Junction Capacitance

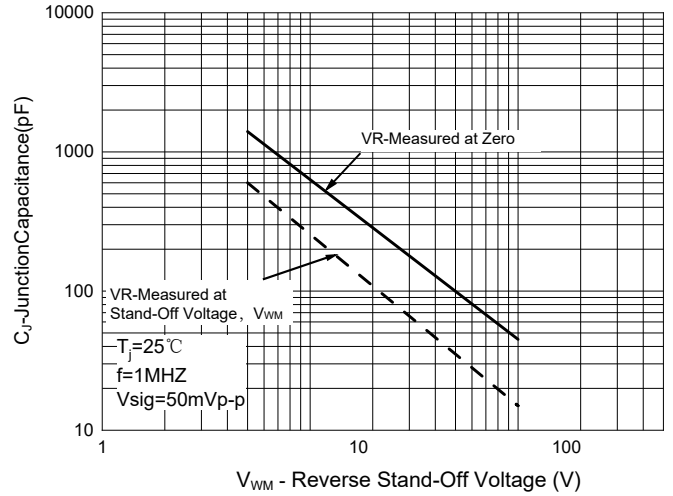

Fig. 3 - Pulse Waveform

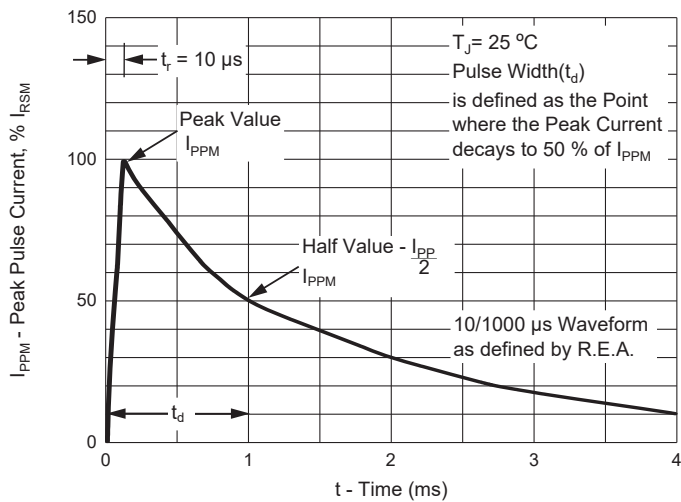
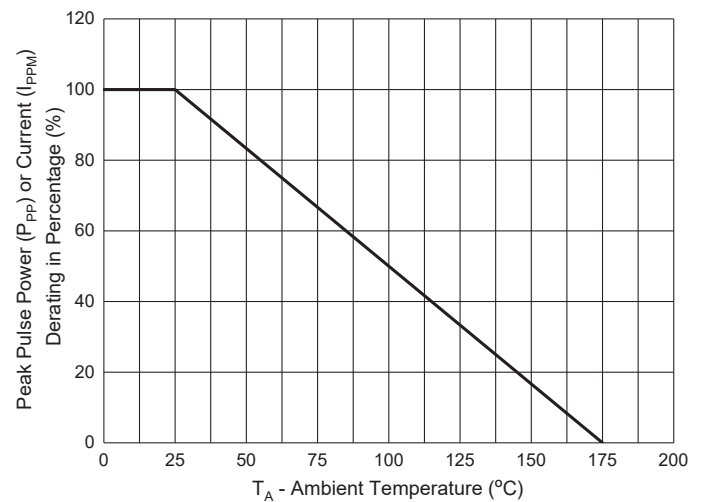

Fig. 4 - Pulse Derating Curve



Ordering Information

Device	Packing
Part Number-TP	Tape&Reel:2.5Kpcs/Reel

*****IMPORTANT NOTICE*****

Micro Commercial Components Corp. reserves the right to make changes without further notice to any product herein to make corrections, modifications, enhancements, improvements, or other changes. *Micro Commercial Components Corp.* does not assume any liability arising out of the application or use of any product described herein; neither does it convey any license under its patent rights, nor the rights of others. The user of products in such applications shall assume all risks of such use and will agree to hold *Micro Commercial Components Corp.* and all the companies whose products are represented on our website, harmless against all damages. *Micro Commercial Components Corp.* products are sold subject to the general terms and conditions of commercial sale, as published at <https://www.mccsemi.com/Home/TermsAndConditions>.

*****LIFE SUPPORT*****

MCC's products are not authorized for use as critical components in life support devices or systems without the express written approval of Micro Commercial Components Corporation.

*****CUSTOMER AWARENESS*****

Counterfeiting of semiconductor parts is a growing problem in the industry. Micro Commercial Components (MCC) is taking strong measures to protect ourselves and our customers from the proliferation of counterfeit parts. MCC strongly encourages customers to purchase MCC parts either directly from MCC or from Authorized MCC Distributors who are listed by country on our web page cited below. Products customers buy either from MCC directly or from Authorized MCC Distributors are genuine parts, have full traceability, meet MCC's quality standards for handling and storage. **MCC will not provide any warranty coverage or other assistance for parts bought from Unauthorized Sources.** MCC is committed to combat this global problem and encourage our customers to do their part in stopping this practice by buying direct or from authorized distributors.