



FCIconnect.com

Copyright FCI.

CONFIGURATION OF CUSTOMER DOCUMENTS

P/N	DOCUMENTS	DWG. NO.	TITLE
HLW_R/S-2C7LF	SPEC	SC-HLW05	CONNECTOR USED FOR FPC/FFC WITH 1mm CONTACT SPACING
	CONNECTOR	JSA96403	CAT NO.TABLE FOR 1mm SPACING CONNECTOR
		JSA96405	1mm SPACING CONNECTOR FOR FPC/FFC
		JSA96406	1mm SPACING CONNECTOR FOR FPC/FFC
	CABLE	JSA93382	RECOMMENDED CABLE(FPC)
		JSA93383	RECOMMENDED CABLE(FFC)
	MANUAL	BJM-HLW101	HANDLING PROCEDURES AND REMARKS

P/N	DOCUMENTS	DWG. NO.	TITLE
HLW_R/S-6C7LF	SPEC	SC-HLW06	CONNECTOR USED FOR C/C WITH 1mm CONTACT SPACING
	CONNECTOR	JSA96404	CAT NO.TABLE FOR 1mm SPACING CONNECTOR
		JSA96407	1mm SPACING CONNECTOR FOR C/C
		JSA96408	1mm SPACING CONNECTOR FOR C/C
	CABLE	JSA93626	RECOMMENDED CABLE(C/C)
	MANUAL	BJM-HLW102	HANDLING PROCEDURES AND REMARKS

mat'l. code				surface <sup>58</sup> / tolerance ISO 1302 <input checked="" type="checkbox"/> ISO 406 ISO 1101		projection 		product family 58PF/QF		CODE JP	
ltr	ecn no	dr	date	tolerances unless otherwise specified		mm 		title 1mm SPACING CONNECTOR DOCUMENT LIST (Cat. No. HLW_R/S-2/6C7LF)			
A	J05-0270	H.T	5/11/05	angles	linear						
B	J05-0293	H.T	5/18/05			scale $\propto$		dwg no sheet 1 of 1 size JSA96418 A4			
C	J05-0517	H.T	8/11/05								
D	J06-0449	H.T	11/2/06	dr	<i>H. Shouji</i> 11/2/06						
				enr	<i>H. Shouji</i> 11/2/06						
				chr	<i>K. Shouji</i> 11/2/06						
				appd	<i>S. Ito</i> 11/2/06						
sheet index	revision sheet	D	1								Rev. D

CAT. NO. & DIMENSIONS

NO. OF CONTACTS (n)	CAT. NO.		DIMENSIONS (NOTE1)		
	RIGHT ANGLE TYPE	STRAIGHT TYPE	A ± 0.3	B ± 0.1	C
4	HLW 4R-2C7LF	HLW 4S-2C7LF	6.6	5.12	3.0
5	HLW 5R-2C7LF	HLW 5S-2C7LF	7.6	6.12	4.0
6	HLW 6R-2C7LF	HLW 6S-2C7LF	8.6	7.12	5.0
7	HLW 7R-2C7LF	HLW 7S-2C7LF	9.6	8.12	6.0
8	HLW 8R-2C7LF	HLW 8S-2C7LF	10.6	9.12	7.0
9	HLW 9R-2C7LF	HLW 9S-2C7LF	11.6	10.12	8.0
10	HLW10R-2C7LF	HLW10S-2C7LF	12.6	11.12	9.0
11	HLW11R-2C7LF	HLW11S-2C7LF	13.6	12.12	10.0
12	HLW12R-2C7LF	HLW12S-2C7LF	14.6	13.12	11.0
13	HLW13R-2C7LF	HLW13S-2C7LF	15.6	14.12	12.0
14	HLW14R-2C7LF	HLW14S-2C7LF	16.6	15.12	13.0
15	HLW15R-2C7LF	HLW15S-2C7LF	17.6	16.12	14.0
16	HLW16R-2C7LF	HLW16S-2C7LF	18.6	17.12	15.0
17	HLW17R-2C7LF	HLW17S-2C7LF	19.6	18.12	16.0
18	HLW18R-2C7LF	HLW18S-2C7LF	20.6	19.12	17.0
19	HLW19R-2C7LF	HLW19S-2C7LF	21.6	20.12	18.0
20	HLW20R-2C7LF	HLW20S-2C7LF	22.6	21.12	19.0
21	HLW21R-2C7LF	HLW21S-2C7LF	23.6	22.12	20.0
22	HLW22R-2C7LF	HLW22S-2C7LF	24.6	23.12	21.0
23	HLW23R-2C7LF	HLW23S-2C7LF	25.6	24.12	22.0
24	HLW24R-2C7LF	HLW24S-2C7LF	26.6	25.12	23.0
25	HLW25R-2C7LF	HLW25S-2C7LF	27.6	26.12	24.0
26	HLW26R-2C7LF	HLW26S-2C7LF	28.6	27.12	25.0
27	HLW27R-2C7LF	HLW27S-2C7LF	29.6	28.12	26.0
28	HLW28R-2C7LF	HLW28S-2C7LF	30.6	29.12	27.0
29	HLW29R-2C7LF	HLW29S-2C7LF	31.6	30.12	28.0
30	HLW30R-2C7LF	HLW30S-2C7LF	32.6	31.12	29.0
31	HLW31R-2C7LF	HLW31S-2C7LF	33.6	32.12	30.0
32	HLW32R-2C7LF	HLW32S-2C7LF	34.6	33.12	31.0

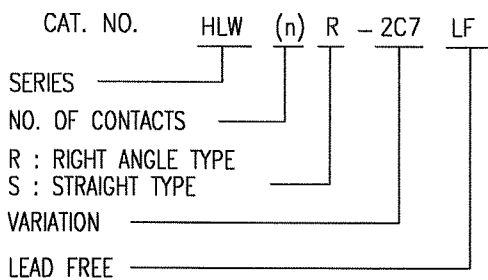

NOTES

1. SEE PART DRAWINGS FOR DIMENSIONS A~C.

mat'l. code				surface 58 / tolerance ISO 406 / ISO 1101		projection		product family 58PF/QF		CODE JP	
ltr ecn no dr date				tolerances unless otherwise specified				title			
A J05-0270 H.T. 5/10/05				angles linear		mm		CAT NO. TABLE FOR 1mm SPACING CONNECTOR (Cat. No. : HLW__R/S-2C7LF)			
B J06-0449 H.T. 11/2/06						scale X		dwg no sheet 1 of 1 size			
				dr engr chr appd				JSA 96403 A4			
								type Product Customer Drawing			
sheet index		revision sheet		B 1						Rev. B	

SC-HLW05 form: A4 JSA96405 96406 93382 93383

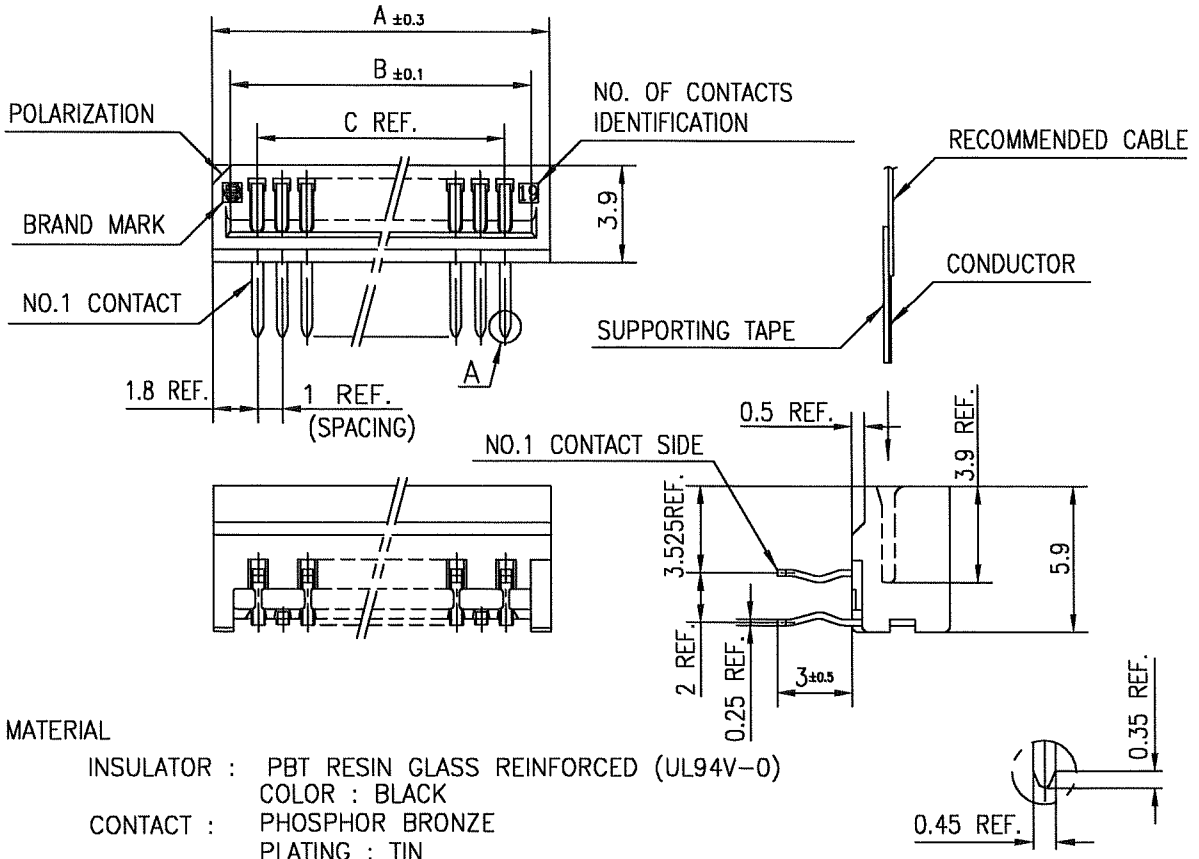

- NOTE
1. THIS PRODUCT IS RIGHT ANGLE TYPE CONNECTOR.
  2. THIS PRODUCT MEETS EUROPEAN UNION DIRECTIVES AND OTHER COUNTRY REGULATIONS AS DESCRIBED IN GS-22-008.
  3. THE HOUSING WILL WITHSTAND EXPOSURE TO 260°C PEAK TEMPERATURE FOR 10 SECONDS IN A WAVE SOLDER APPLICATION WITH A 1.6mm THICK CIRCUIT BOARD.

RECOMMENDED PC BOARD  
 THICKNESS : 1.2~1.6  
 HOLE PATTERN (COMPONENT SIDE)

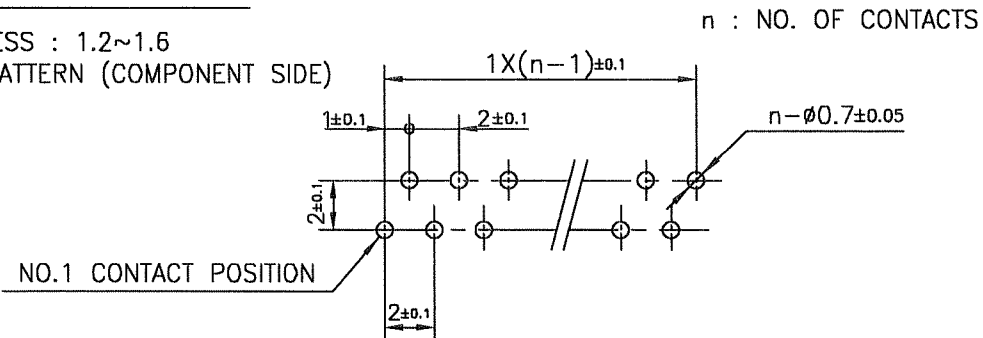

mat'l. code				surface 58 / tolerance ISO 406 / ISO 1302 ✓ / ISO 1101		projection		product family 58PF		CODE JP	
ltr	ecn no	dr	date	tolerances unless otherwise specified		mm		title			
A	J05-0270	H.T	5/10/05	±0.2		mm		1mm SPACING CONNECTOR FOR FPC/FFC (Cat. No. :HLW__R-2C7LF)			
B	J05-0735	H.T	10/28/05	angles	linear	mm		dwg no			
C	J06-0449	H.T	11/2/06			scale X		sheet 1 of 1 size			
				dr	FCI		JSA 96405				A4
				enr			type				Rev.
				chr			Product Customer Drawing				C
				appd							
sheet index		revision sheet		C							
1		1									

SC-HLW05 JSA96403 form: A4

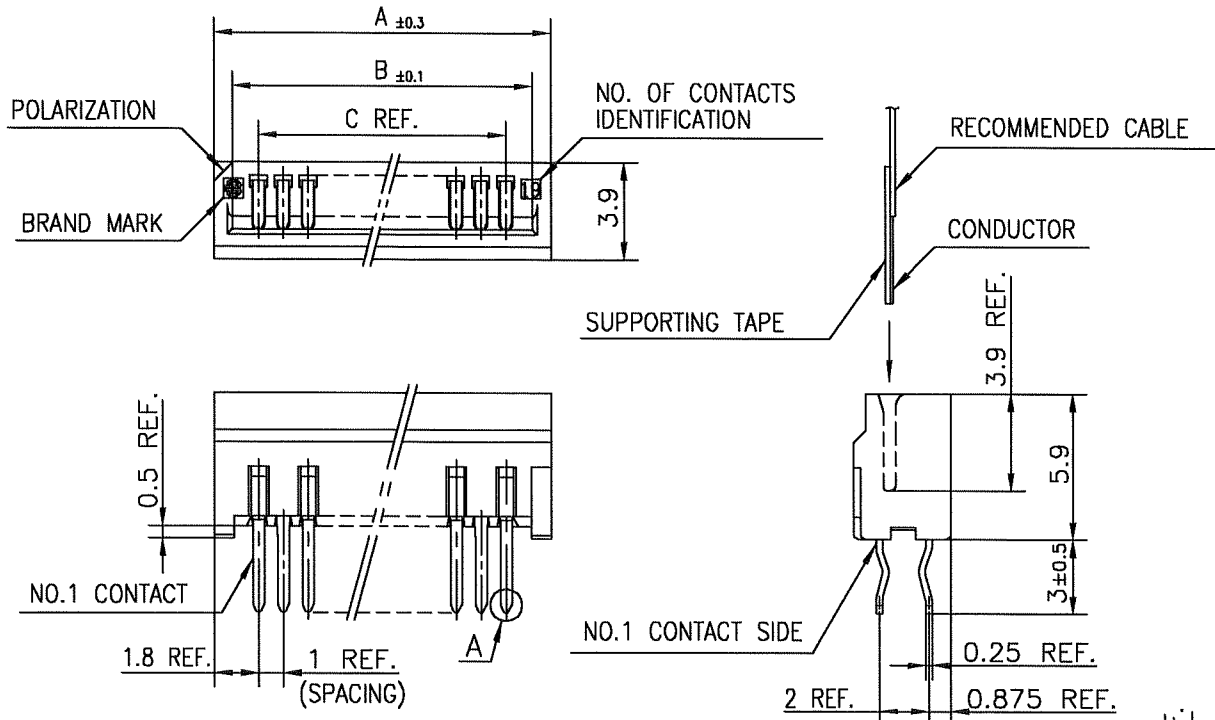

**MATERIAL**  
 INSULATOR : PBT RESIN GLASS REINFORCED (UL94V-0)  
 COLOR : BLACK  
 CONTACT : PHOSPHOR BRONZE  
 PLATING : TIN

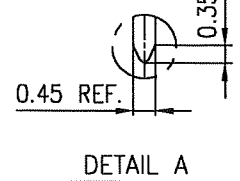

- NOTE 1. THIS PRODUCT IS STRAIGHT TYPE CONNECTOR.  
 2. THIS PRODUCT MEETS EUROPEAN UNION DIRECTIVES AND OTHER COUNTRY REGULATIONS AS DESCRIBED IN GS-22-008.  
 3. THE HOUSING WILL WITHSTAND EXPOSURE TO 260°C PEAK TEMPERATURE FOR 10 SECONDS IN A WAVE SOLDER APPLICATION WITH A 1.6mm THICK CIRCUIT BOARD.

**RECOMMENDED PC BOARD**

THICKNESS : 1.2~1.6  
 HOLE PATTERN (COMPONENT SIDE)

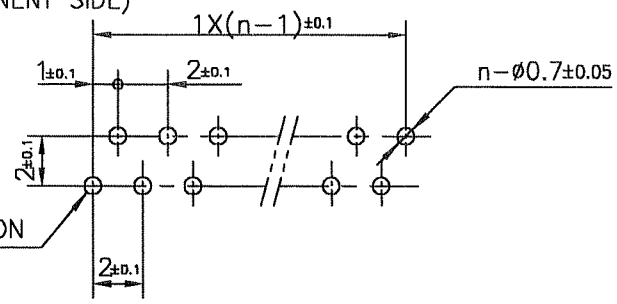

n : NO. OF CONTACTS

mat'l. code				surface 58 / tolerance ISO 406 / ISO 1302 / ISO 1101		projection		product family 58QF		CODE JP	
ltr	ecn no	dr	date	tolerances unless otherwise specified		mm		title			
A	J05-0270	H.T	5/10/05	±0.2		mm		1mm SPACING CONNECTOR FOR FPC/FFC (Cat. No. :HLW__S-2C7LF)			
B	J05-0735	H.T	10/28/05	linear		scale X		dwg no JSA 96406 sheet 1 of 1 size A4			
C	J06-0449	H.T	11/2/06			FCI		type Product Customer Drawing			
sheet index		revision	C							Rev. C	
		sheet	1								

RECOMMENDED CABLE (FPC)

n : NO. OF CONDUCTORS

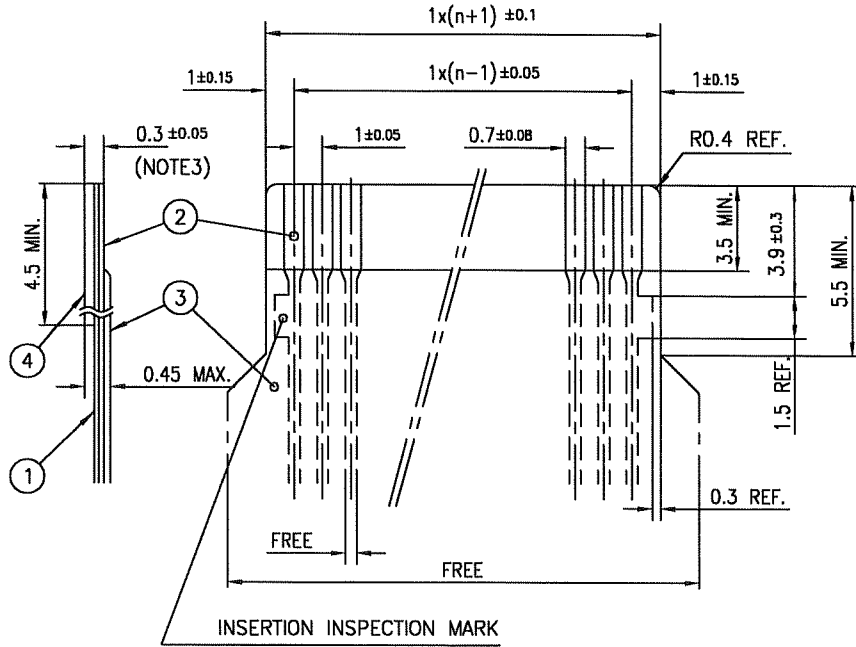

PT. NO.	DESCRIPTION	MATERIAL	THICKNESS (μm)
1	BASE FILM	POLYIMIDE OR POLYESTER OR EQUIVALENT	25
2	CONDUCTOR	COPPER FOIL (PLATING : SOLDER 1μm MIN.)	35
3	OVERLAY	POLYIMIDE OR POLYESTER OR EQUIVALENT	—
4	SUPPORTING TAPE	POLYESTER OR POLYIMIDE OR EQUIVALENT	188

NOTES

1. NO BURR AT EACH PORTION.
2. NO PEELING IN COMMON USE.
3. TOTAL THICKNESS LIMIT OF EACH MATERIAL (INCLUDING ADHESIVE AGENT) IS SPECIFIED.

mat'l. code				surface 58 / tolerance ISO 406 ISO 1101		projection		product family 58PF/QF		CODE JP	
ltr ecn no dr date				tolerances unless otherwise specified		mm		title			
AA J05-0270 H.T 5/11/05				angles linear		mm		RECOMMENDED CABLE (FPC)			
AB J06-0449 H.T 11/2/06						scale X		(Cat. No. HLW__R/S-___)			
				dr		FCI		dwg no		sheet 1 of 1 size	
				enr				JSA 93382		A4	
				chr				type Product Customer Drawing			
				appd							
sheet index		revision sheet		AB 1						Rev. AB	



FCIconnect.com

Copyright FCI.

RECOMMENDED CABLE (FFC)

n : NO. OF CONDUCTORS

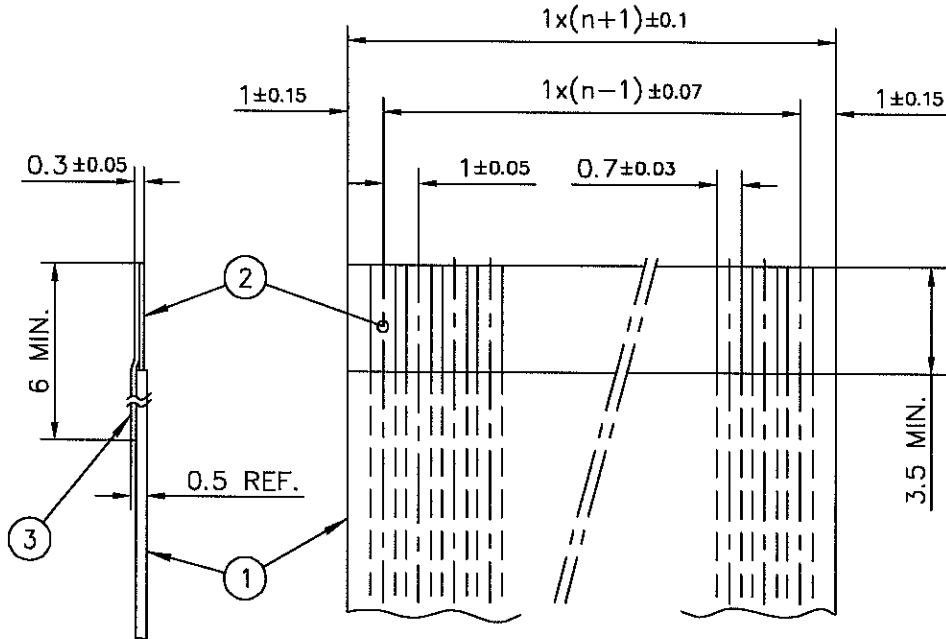

PT. NO.	DESCRIPTION	MATERIAL	NOTE
1	INSULATOR	FLAME RESISTING POLYESTER OR EQUIVALENT	_____
2	CONDUCTOR	COPPER FOIL	PLATING : TIN OR SOLDER 1 μm MIN.
3	SUPPORTING TAPE	FLAME RESISTING POLYESTER OR EQUIVALENT	_____

NOTES

1. NO BURR AT EACH PORTION.
2. NO PEELING IN COMMON USE.

mat'l. code				surface 58 / tolerance ISO 1302 / ISO 406 / ISO 1101		projection		product family 58PF/QF		CODE JP	
litr ecn no dr date				tolerances unless otherwise specified		mm		title			
AA J05-0270 H.T 5/11/05				angles linear		mm		RECOMMENDED CABLE (FFC)			
AB J06-0449 H.T 11/2/06						scale X		(Cat. No. HLW__R/S-__)			
				dr 11/2/06		FCI		dwg no sheet 1 of 1 size			
				enrg 11/2/06				JSA 93383		A4	
				chr R. Shouje 11/2/06				type Product Customer Drawing			
				appd S. De.dan 11/2/06							
sheet index		revision sheet		AB 1						Rev AB	

form: A4

1

2

FCI  
FCIconnect.com

Copyright FCI.

CAT. NO. & DIMENSIONS

NO. OF CONTACTS (n)	CAT. NO.		DIMENSIONS (NOTE1)		
	RIGHT ANGLE TYPE	STRAIGHT TYPE	A ± 0.3	B ± 0.1	C
4	HLW 4R-6C7LF	HLW 4S-6C7LF	6.6	5.12	3.0
5	HLW 5R-6C7LF	HLW 5S-6C7LF	7.6	6.12	4.0
6	HLW 6R-6C7LF	HLW 6S-6C7LF	8.6	7.12	5.0
7	HLW 7R-6C7LF	HLW 7S-6C7LF	9.6	8.12	6.0
8	HLW 8R-6C7LF	HLW 8S-6C7LF	10.6	9.12	7.0
9	HLW 9R-6C7LF	HLW 9S-6C7LF	11.6	10.12	8.0
10	HLW10R-6C7LF	HLW10S-6C7LF	12.6	11.12	9.0
11	HLW11R-6C7LF	HLW11S-6C7LF	13.6	12.12	10.0
12	HLW12R-6C7LF	HLW12S-6C7LF	14.6	13.12	11.0
13	HLW13R-6C7LF	HLW13S-6C7LF	15.6	14.12	12.0
14	HLW14R-6C7LF	HLW14S-6C7LF	16.6	15.12	13.0
15	HLW15R-6C7LF	HLW15S-6C7LF	17.6	16.12	14.0
16	HLW16R-6C7LF	HLW16S-6C7LF	18.6	17.12	15.0
17	HLW17R-6C7LF	HLW17S-6C7LF	19.6	18.12	16.0
18	HLW18R-6C7LF	HLW18S-6C7LF	20.6	19.12	17.0
19	HLW19R-6C7LF	HLW19S-6C7LF	21.6	20.12	18.0
20	HLW20R-6C7LF	HLW20S-6C7LF	22.6	21.12	19.0
21	HLW21R-6C7LF	HLW21S-6C7LF	23.6	22.12	20.0
22	HLW22R-6C7LF	HLW22S-6C7LF	24.6	23.12	21.0
23	HLW23R-6C7LF	HLW23S-6C7LF	25.6	24.12	22.0
24	HLW24R-6C7LF	HLW24S-6C7LF	26.6	25.12	23.0
25	HLW25R-6C7LF	HLW25S-6C7LF	27.6	26.12	24.0
26	HLW26R-6C7LF	HLW26S-6C7LF	28.6	27.12	25.0
27	HLW27R-6C7LF	HLW27S-6C7LF	29.6	28.12	26.0
28	HLW28R-6C7LF	HLW28S-6C7LF	30.6	29.12	27.0
29	HLW29R-6C7LF	HLW29S-6C7LF	31.6	30.12	28.0
30	HLW30R-6C7LF	HLW30S-6C7LF	32.6	31.12	29.0
31	HLW31R-6C7LF	HLW31S-6C7LF	33.6	32.12	30.0
32	HLW32R-6C7LF	HLW32S-6C7LF	34.6	33.12	31.0

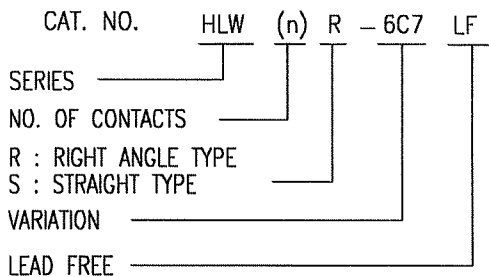

NOTES

1. SEE PART DRAWINGS FOR DIMENSIONS A~C.

mat'l. code				surface 5B / ISO 1302 ✓		tolerance ISO 406 / ISO 1101		projection		product family 58PF/QF		CODE JP	
ltr	ecn no	dr	date	tolerances unless otherwise specified				mm		title CAT NO. TABLE FOR 1mm SPACING CONNECTOR (Cat. No. : HLW__R/S-6C7LF)			
A	J05-0270	H.T	5/10/05	angles	linear	scale X							
B	J06-0449	H.T	11/2/06	dr	<i>H. Hatakeyama</i>	<i>11/2/06</i>			dwg no		sheet 1 of 1		size
				enrg	<i>H. Hatakeyama</i>	<i>11/2/06</i>			JSA 96404				A4
				chr	<i>R. Strong</i>	<i>11/2/06</i>			type		Product Customer Drawing		
				appd	<i>J. Dudaew</i>	<i>11/2/06</i>							
sheet index	revision	B											Rev. B

SC-HLW06 JSA96407 96408 93626 form: A4

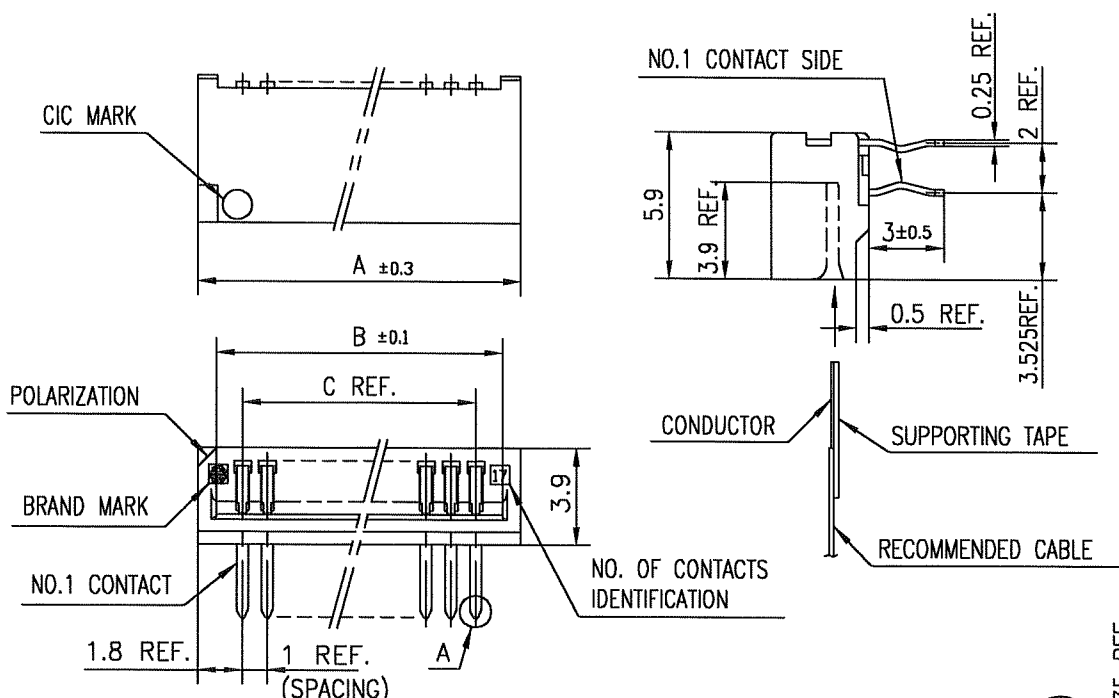

**MATERIAL**  
 INSULATOR : PBT RESIN GLASS REINFORCED (UL94V-0)  
 COLOR : BLACK  
 CONTACT : PHOSPHOR BRONZE  
 PLATING : TIN

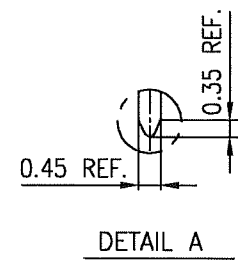

- NOTE**
- 1.THIS PRODUCT IS RIGHT ANGLE TYPE CONNECTOR.
  - 2.THIS PRODUCT MEETS EUROPEAN UNION DIRECTIVES AND OTHER COUNTRY REGULATIONS AS DESCRIBED IN GS-22-008.
  - 3.THE HOUSING WILL WITHSTAND EXPOSURE TO 260°C PEAK TEMPERATURE FOR 10 SECONDS IN A WAVE SOLDER APPLICATION WITH A 1.6mm THICK CIRCUIT BOARD.

**RECOMMENDED PC BOARD**  
 THICKNESS : 1.2~1.6  
 HOLE PATTERN (COMPONENT SIDE)

n : NO. OF CONTACTS

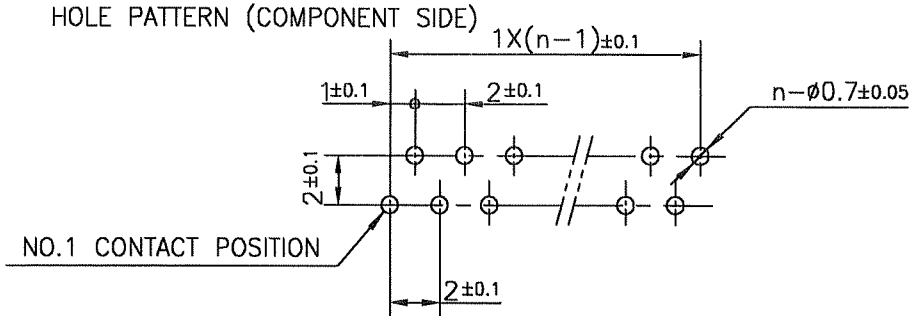

mat'l. code				surface 58 / ISO 1302 ✓		tolerance ISO 406 / ISO 1101		projection		product family 58PF		CODE JP	
ltr				ecn no		dr		date		title		1mm SPACING CONNECTOR FOR CIC (Cat. No. :HLW_R-6C7LF)	
A				J05-0270		H.T		5/10/05		mm		scale X	
B				J05-0735		H.T		10/28/05		angles		linear ±0.2	
C				J06-0449		H.T		11/2/06		dr		sheet 1 of 1 size A4	
										engr		JSA 96407	
										chr		sheet 1 of 1 size A4	
										appd		type Product Customer Drawing	
sheet index		revision sheet		C		1						Rev. C	

Copyright FCI. FCIconnect.com

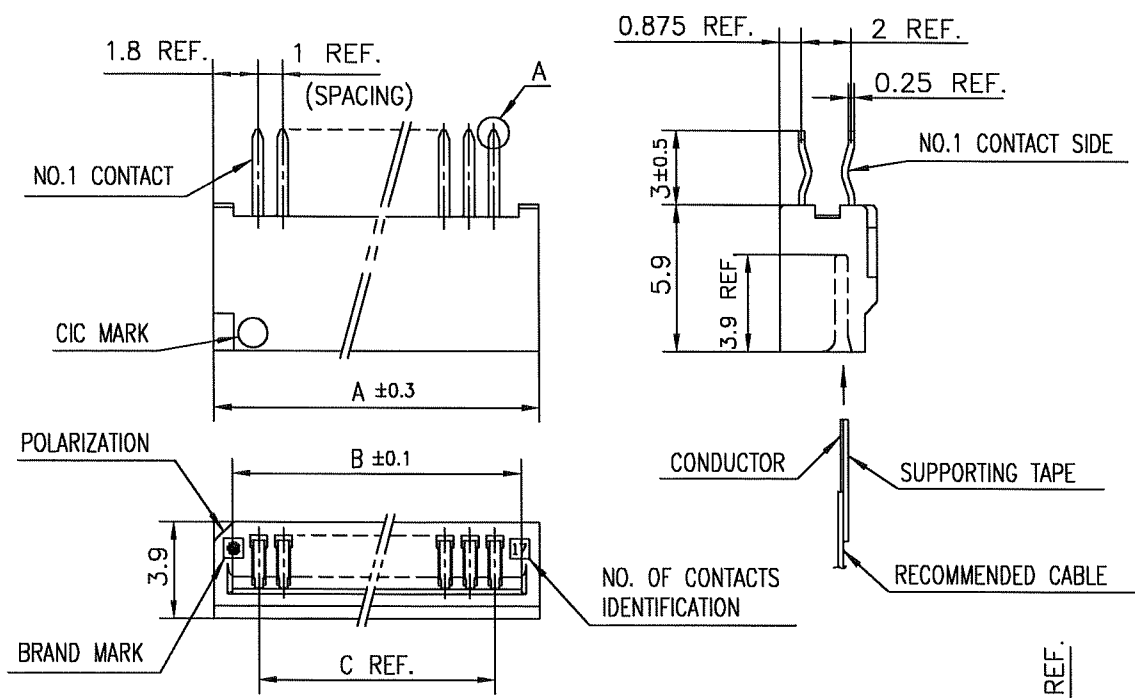

MATERIAL

INSULATOR : PBT RESIN GLASS REINFORCED (UL94V-0)  
 COLOR : BLACK  
 CONTACT : PHOSPHOR BRONZE  
 PLATING : TIN

NOTE

1. THIS PRODUCT IS STRAIGHT TYPE CONNECTOR.
2. THIS PRODUCT MEETS EUROPEAN UNION DIRECTIVES AND OTHER COUNTRY REGULATIONS AS DESCRIBED IN GS-22-008.
3. THE HOUSING WILL WITHSTAND EXPOSURE TO 260°C PEAK TEMPERATURE FOR 10 SECONDS IN A WAVE SOLDER APPLICATION WITH A 1.6mm THICK CIRCUIT BOARD.

RECOMMENDED PC BOARD

THICKNESS : 1.2~1.6  
 HOLE PATTERN (COMPONENT SIDE)

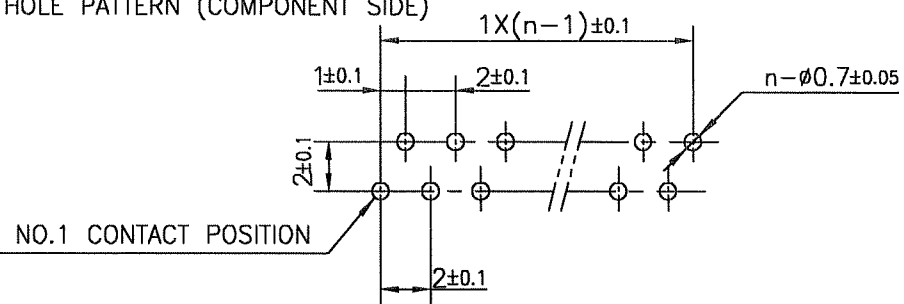

n : NO. OF CONTACTS

mat'l. code				surface 58 / tolerance ISO 406 / ISO 1302 / ISO 1101		projection		product family 58QF		CODE JP		
ltr	ecn no	dr	date	tolerances unless otherwise specified		mm		title				
A	J05-0270	H.T	5/10/05	±0.2		↔		1mm SPACING CONNECTOR FOR CIC (Cat. No. :HLW__S-6C7LF)				
B	J05-0735	H.T	10/28/05	angles	linear	↗		dwg no sheet 1 of 1 size				
C	J06-0449	H.T	11/2/01			scale X		JSA 96408 A4				
				dr	11/2/06		FCI		type Product Customer Drawing			
				enr	11/2/06							
				chr	11/2/06							
				appd	11/2/06							
sheet index	revision	C	1									Rev. c



FCIconnect.com

Copyright FCI.

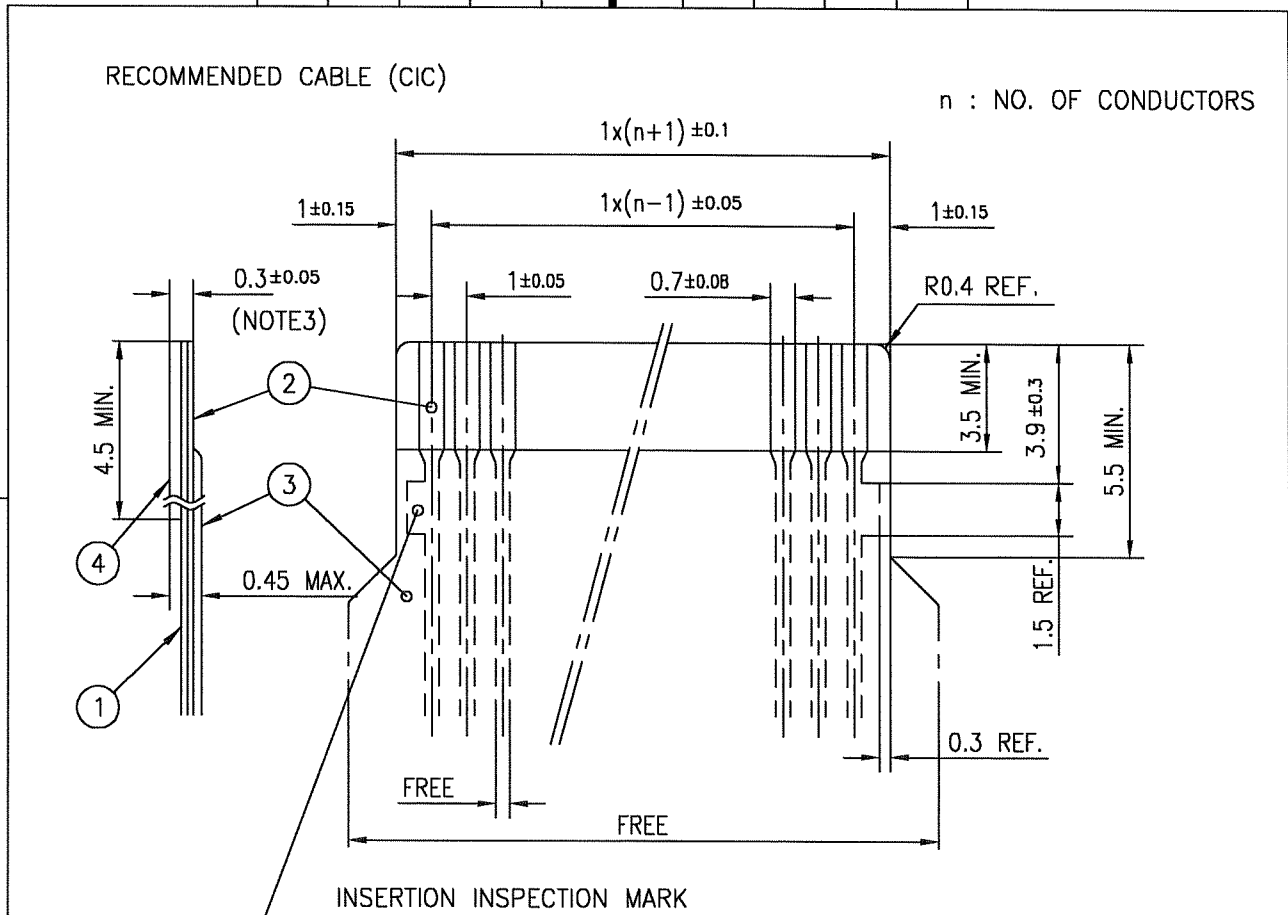

PT. NO.	DESCRIPTION	MATERIAL	THICKNESS (μm)	
1	BASE FILM	POLYESTER OR EQUIVALENT	75	25
2	CONDUCTOR	CARBON PASTE OVER SILVER PASTE	10 MIN.	
3	OVERLAY	POLYIMIDE OR POLYESTER OR EQUIVALENT	—	
4	SUPPORTING TAPE	POLYESTER OR POLYIMIDE OR EQUIVALENT	188	250

NOTES

1. NO BURR AT EACH PORTION.
2. NO PEELING IN COMMON USE.
3. TOTAL THICKNESS LIMIT OF EACH MATERIAL (INCLUDING ADHESIVE AGENT) IS SPECIFIED.

mat'l. code				surface ISO 1302 ✓	tolerance ISO 406 ISO 1101	projection ⊕	product family 58PF/QF	CODE JP
ltr	ecn no	dr	date	tolerances unless otherwise specified		mm ↔	title RECOMMENDED CABLE (CIC) (Cat. No. HLW__R/S-__)	
AA	J05-0270	H.T	5/11/05	angles	linear			
AB	J06-0449	H.T	11/2/06			scale	dwg no JSA 93626	
				dr	<i>H. Saito</i>	11/2/06	sheet 1 of 1 size A4	
				enr	<i>H. Saito</i>	11/2/06	type Product Customer Drawing	
				chr	<i>K. Shoji</i>	11/2/06		
				appd	<i>S. Nakano</i>	11/7/06		
sheet index	revision sheet	AB	1					Rev. AB



FCIconnect.com

Copyright FCI.

