

CONMHF4-SMD-G

MHF4 Jack PCB Surface-Mount Connector

The CONMHF4-SMD is an MHF4-type jack (male pin) PCB surface-mount connector designed for reflow-solder mounting directly to a printed circuit board. Operating from 0 Hz to 6 GHz, the CONMHF4-SMD combines superior performance, compact size, and a convenient snap-on mating interface to provide a reliable, easy-to-use connector. Additionally, all Linx connectors meet RoHS lead free standards and are tested to meet requirements for corrosion resistance, vibration, mechanical and thermal shock.

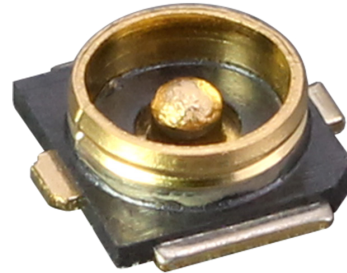

Features

- 0 Hz to 6 GHz operation
- Gold plating
 - Superior corrosion resistance
- MHF4-type jack (male pin) connection
 - Gold plated brass center contact
- Direct PCB attachment
- Reflow- or hand-solder assembly

Applications

- LPWA
 - LoRaWAN®, Sigfox®, WiFi HaLow™ (802.11ah)
- Cellular IoT
 - LTE-M (Cat-M1), NB-IoT
- Cellular
 - 5G/4G LTE/3G/2G
- GNSS
 - GPS, Galileo, GLONASS, BeiDou, QZSS
- Industrial/Commercial/Enterprise
- ISM

Table 1. Electrical Specifications

Impedance	50 Ω	
Frequency Range	0 Hz to 6 GHz	
Voltage Rating	60 V RMS	
Contact Resistance	Center: ≤ 20.0 mΩ Outer: ≤ 20.0 mΩ	
Insulation Resistance	500 MΩ min.	
Select Frequencies	2.4 GHz	5 GHz
Insertion Loss (dB max)	0.58	1.57
VSWR (max)	1.1	1.8

Ordering Information

Part Number	Description
CONMHF4-SMD-G-T	MHF4-type gold plated jack (male pin) PCB surface-mount connector in tape and reel (10,000 per reel)

Available from Linx Technologies and select distributors and representatives.

Product Dimensions

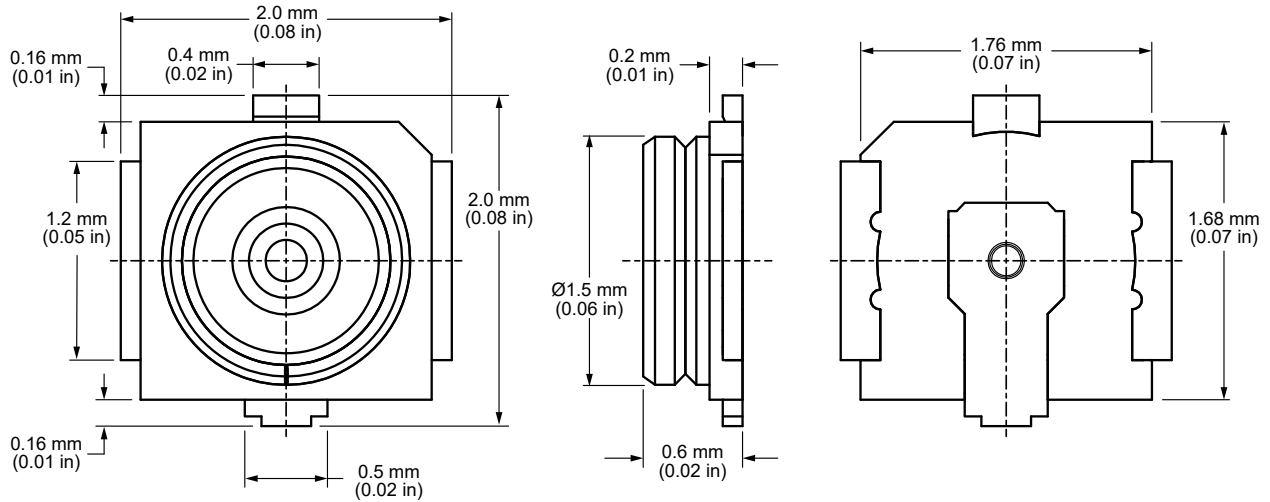

Figure 1. Product Dimensions for the CONMHF4-SMD-G Connector

Table 2. Connector Components

Model	CONMHF4-SMD-G	
Connector Part	Material	Finish
Connector Body	LCP, UL94V-0	-
Outer Contact	Brass	Gold
Center Contact (male pin)	Brass	Gold
Signal Contact	Phosphor Bronze	Gold
Ground Contact	Phosphor Bronze	Gold

Recommended PCB Footprint

Figure 2 shows the connectors recommended PCB footprint.

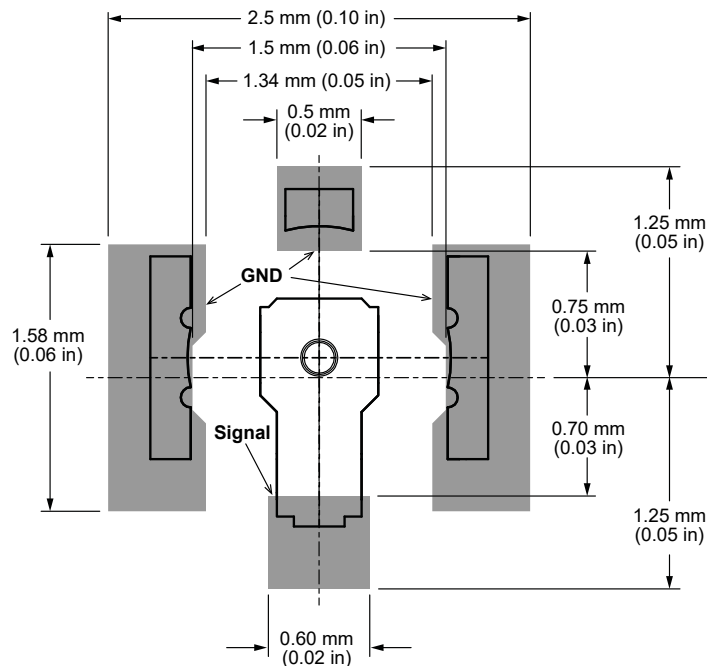

Figure 2. Recommended PCB Dimensions for the CONMHF4-SMD

Connector Performance

Table 3 shows insertion loss and VSWR values for the CONMHF4-SMD-G connector at commonly used frequencies.

Insertion loss is the loss of signal power (gain) resulting from the insertion of a device in a transmission line. VSWR describes how efficiently power is transmitted through the connector. A lower VSWR value indicates better performance at a given frequency.

Table 3. Insertion Loss and VSWR for the CONMHF4-SMD-G Connector

Band	Low-Band Cellular/ISM/LPWA	GNSS	Midband Cellular	WiFi/ISM
Frequency Range	400 MHz to 960 MHz	1164 MHz to 1609 MHz	1427 MHz to 5000 MHz	2.4 GHz
Insertion Loss (dB max)	0.33	0.43	1.60	0.58
VSWR (max)	1.1	1.8	1.1	1.1

Table 4. Mechanical Specifications

Model	CONMHF4-SMD-G
Mounting Type	PCB Surface-Mount
Fastening Type	Snap-on Coupling
Interface in Accordance with	EIA-364
Connector Durability	30 cycles min.
Weight	0.01 g (0.0004 oz)

Table 5. Environmental Specifications

STD, Test Condition	
Corrosion (Salt spray)	EIA 364-26
Thermal Shock	EIA 364-32
Vibration	EIA 364-28
Mechanical Shock	EIA 364-27
Temperature Range	-40 °C to +90 °C
Environmental Compliance	RoHS

Reflow Solder Profile

Figure 3 shows the time and temperature data for reflow soldering the connector to a PCB.

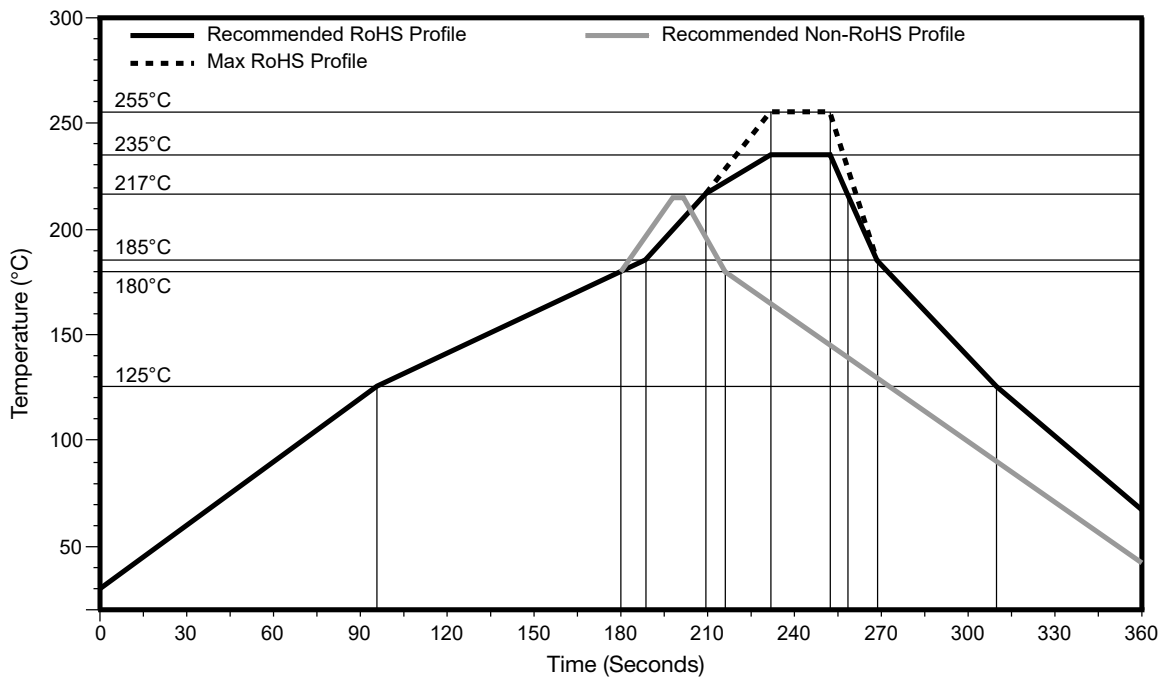

Figure 3. CONMHF4-SMD Recommended Reflow Solder Profile

Packaging Information

Figure 4 shows the tape dimensions for the CONMHF4-SMD connector. The reel specifications are provided in Figure 5.

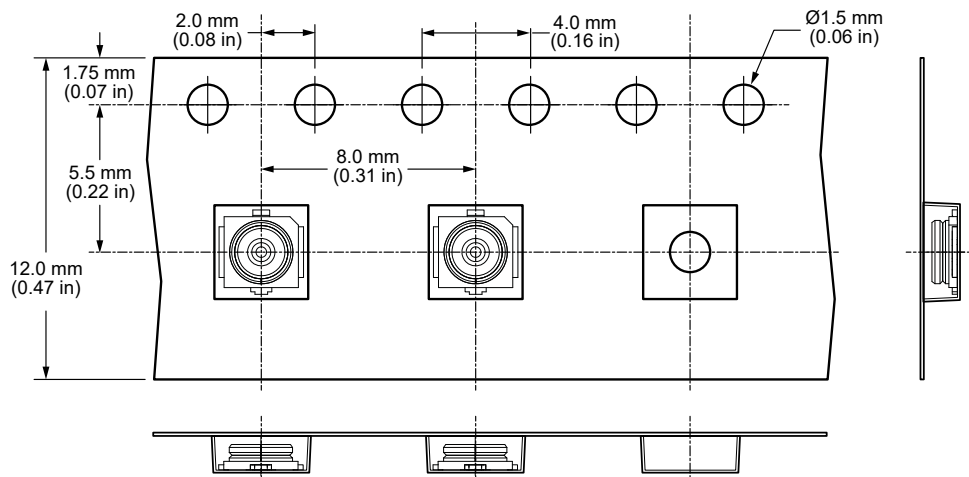
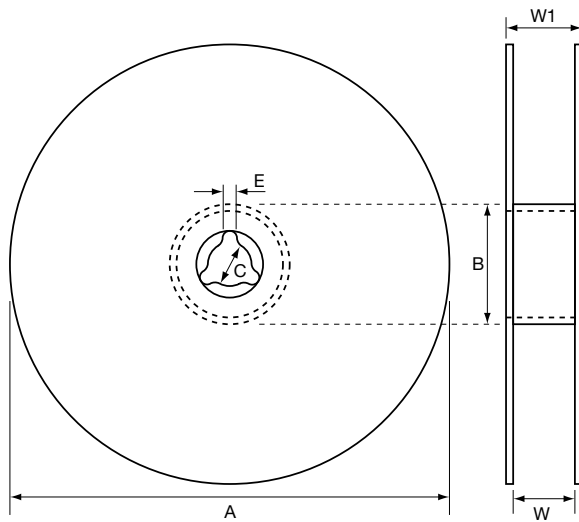

Figure 4. Tape Specifications for the CONMHF4-SMD Connector

Packaging Information (Continued)



Reel Dimensions		
Symbol	Qty	Unit
QTY per reel	10,000	pcs
Tape width	12.00	mm
A	$\varnothing 330 \pm 1$	mm
B	$\varnothing 100 \pm 0.5$	mm
C	$\varnothing 13.00 \pm 0.2$	mm
E	2.2 ± 0.5	mm
W	12 ± 0.5	mm
W1	16.4 ± 0.2	mm

Figure 5. Reel Specifications for the CONMHF4-SMD Connector

Website: <http://linxtechnologies.com>
Linx Offices: 159 Ort Lane, Merlin, OR, US 97532
Phone: +1 (541) 471-6256
E-MAIL: info@linxtechnologies.com

Linx Technologies reserves the right to make changes to the product(s) or information contained herein without notice. No liability is assumed as a result of their use or application. No rights under any patent accompany the sale of any such product(s) or information.

Wireless Made Simple is a registered trademark of Linx Acquisitions LLC. LoRaWAN is a registered trademark of Semtech Corporation. Sigfox is a registered trademark of SIGFOX. Other product and brand names may be trademarks or registered trademarks of their respective owners.

Copyright © 2021 Linx Technologies

All Rights Reserved

Doc# DS21342-167CON Replaces (DS21260-167CON)

