



AC/DC Converter
Non-Isolation Buck Converter PWM method
12 W 12 V
BM2P016 Reference Board

User's Guide

<High Voltage Safety Precautions>

◇ Read all safety precautions before use

Please note that this document covers only the BM2P016 evaluation board (BM2P016-EVK-002) and its functions. For additional information, please refer to the datasheet.

To ensure safe operation, please carefully read all precautions before handling the evaluation board



Depending on the configuration of the board and voltages used,

Potentially lethal voltages may be generated.

Therefore, please make sure to read and observe all safety precautions described in the red box below.

Before Use

- [1] Verify that the parts/components are not damaged or missing (i.e. due to the drops).
- [2] Check that there are no conductive foreign objects on the board.
- [3] Be careful when performing soldering on the module and/or evaluation board to ensure that solder splash does not occur.
- [4] Check that there is no condensation or water droplets on the circuit board.

During Use

- [5] Be careful to not allow conductive objects to come into contact with the board.
- [6] **Brief accidental contact or even bringing your hand close to the board may result in discharge and lead to severe injury or death.**

Therefore, DO NOT touch the board with your bare hands or bring them too close to the board.

In addition, as mentioned above please exercise extreme caution when using conductive tools such as tweezers and screwdrivers.

- [7] If used under conditions beyond its rated voltage, it may cause defects such as short-circuit or, depending on the circumstances, explosion or other permanent damages.
- [8] Be sure to wear insulated gloves when handling is required during operation.

After Use

- [9] The ROHM Evaluation Board contains the circuits which store the high voltage. Since it stores the charges even after the connected power circuits are cut, please discharge the electricity after using it, and please deal with it after confirming such electric discharge.
- [10] Protect against electric shocks by wearing insulated gloves when handling.

This evaluation board is intended for use only in research and development facilities and should be handled **only by qualified personnel familiar with all safety and operating procedures.**

We recommend carrying out operation in a safe environment that includes the use of high voltage signage at all entrances, safety interlocks, and protective glasses.

AC/DC Converter

Non-Isolation Buck Converter PWM method Output 12 W 12 V

BM2P016 Reference Board

BM2P016-EVK-002

The BM2P016-EVK-002 evaluation board outputs a 12 V voltage from an input of 90 Vac to 264 Vac. The output current provides up to 1.0 A. The BM2P016 PWM type DC / DC converter IC with 650 V MOSFET is used. The BM2P016 contributes to low power consumption by incorporating a 650 V withstand voltage startup circuit. Using current mode control, cycle-by-cycle current limiting provides excellent performance in bandwidth and transient response. The switching frequency is fixed at 65 kHz. At light loads, frequency reduction achieves high efficiency. Built-in frequency hopping function contributes to low EMI. The low on-resistance 1.4 Ω · 650 V withstand voltage MOSFET is built in, contributing to low power consumption and easy design.

The optimized EMI design complies with CISPR 22 Class B for noise terminal voltage / radiation emission testing.



Figure 1. BM2P016-EVK-002

Electronics Characteristics

Not guarantee the characteristics, is representative value. Unless otherwise noted: $V_{IN} = 230 \text{ Vac}$, $I_{OUT} = 500 \text{ mA}$, $T_a = 25 \text{ }^\circ\text{C}$

Parameter	Min	Typ	Max	Units	Conditions
Input Voltage Range	90	230	264	Vac	
Input Frequency	47	50/60	63	Hz	
Output Voltage	10.8	12.0	13.2	V	
Maximum Output Power	-	-	12.0	W	$I_{OUT} = 1000\text{mA}$
Output Current Range ^(NOTE1)	0	500	1000	mA	
Stand-by Power	-	110	-	mW	$I_{OUT} = 0\text{A}$
Efficiency	-	81.2	-	%	
Output Ripple Voltage ^(NOTE2)	-	42	-	mVpp	
Operating Temperature Range	-10	25	65	$^\circ\text{C}$	

(NOTE1) Please adjust operating time, within any parts surface temperature under 105 $^\circ\text{C}$

(NOTE2) Not include spike noise

Operation Procedure

1. Operation Equipment

- (1) AC Power supply 90 ~ 264 Vac, over 20W
- (2) Electronic Load capacity 1.0 A
- (3) Multi meter

2. Connect method

- (1) AC power supply presetting range 90~264 Vac, Output switch is off.
- (2) Load setting under 1.0 A. Load switch is off.
- (3) AC power supply N terminal connect to the board AC (N) of CN1-1, and L terminal connect to AC (L) of CN1-2.
- (4) Load + terminal connect to VOUT terminal, Load – terminal connect to GND terminal.
- (5) AC power meter connect between AC power supply and board.
- (6) Output test equipment connects to output terminal
- (7) AC power supply switch ON.
- (8) Check that output voltage is 12 V
- (9) Electronic load switch ON
- (10) Check output voltage drop by load connect wire resistance

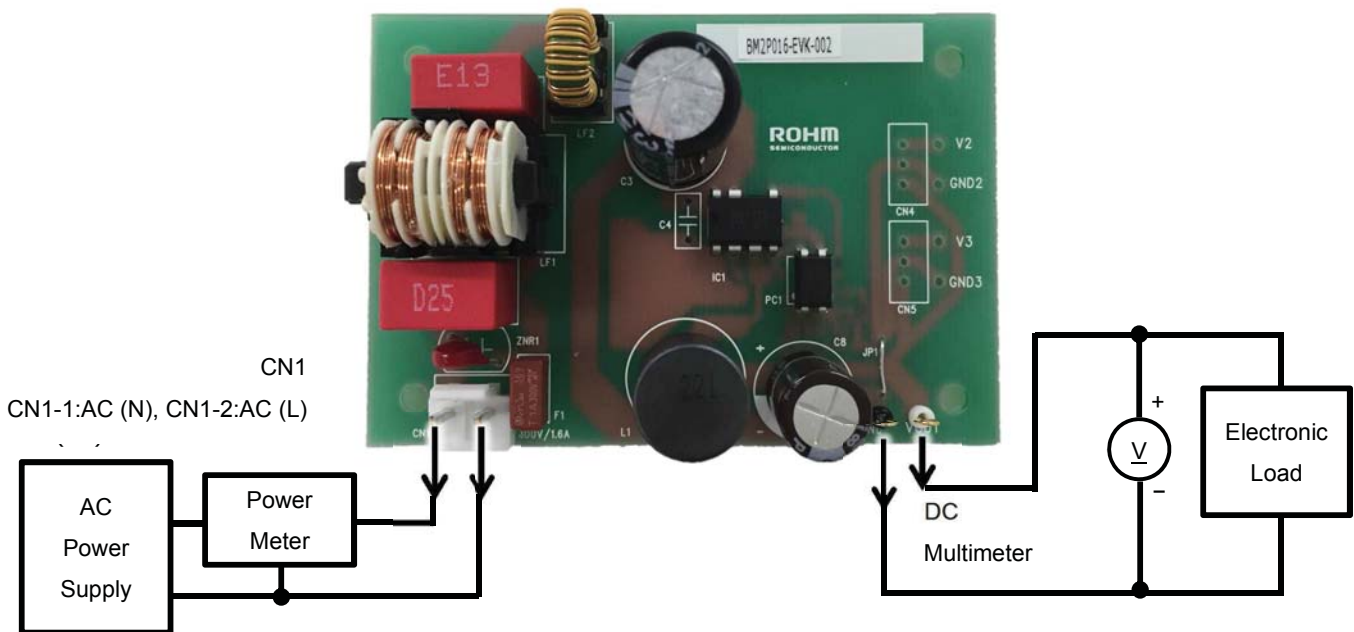

Figure 2. Connection Circuit

Deleting

The operating temperature range of this evaluation board is -10 to 65 °C. Make sure that the part surface temperature does not exceed 105 °C. The maximum power that can be supplied continuously is 6.0 W ($I_{OUT} = 0.5 A$). The figure below shows the derating curve. A load of 8.0 W ($I_{OUT} = 0.67 A$) can be applied continuously until the ambient temperature is -10 °C to 40 °C. The temperature from 40 °C to 65 °C follows the derating curve. The maximum power that can be supplied instantaneously is 12 W ($I_{OUT} = 1.0 A$). When using the product beyond the derating curve, adjust the load current time so that the component surface temperature does not exceed 105 °C within the operating temperature range (-10 to 65 °C).

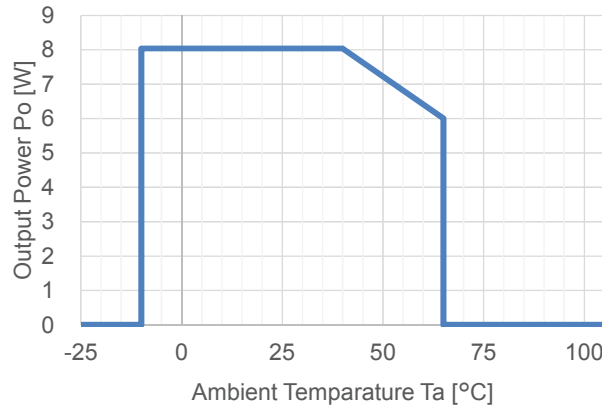

Figure 3. Temperature Derating curve

Application Circuit

$V_{IN} = 90 \sim 264 Vac$, $V_{OUT} = 12 V$

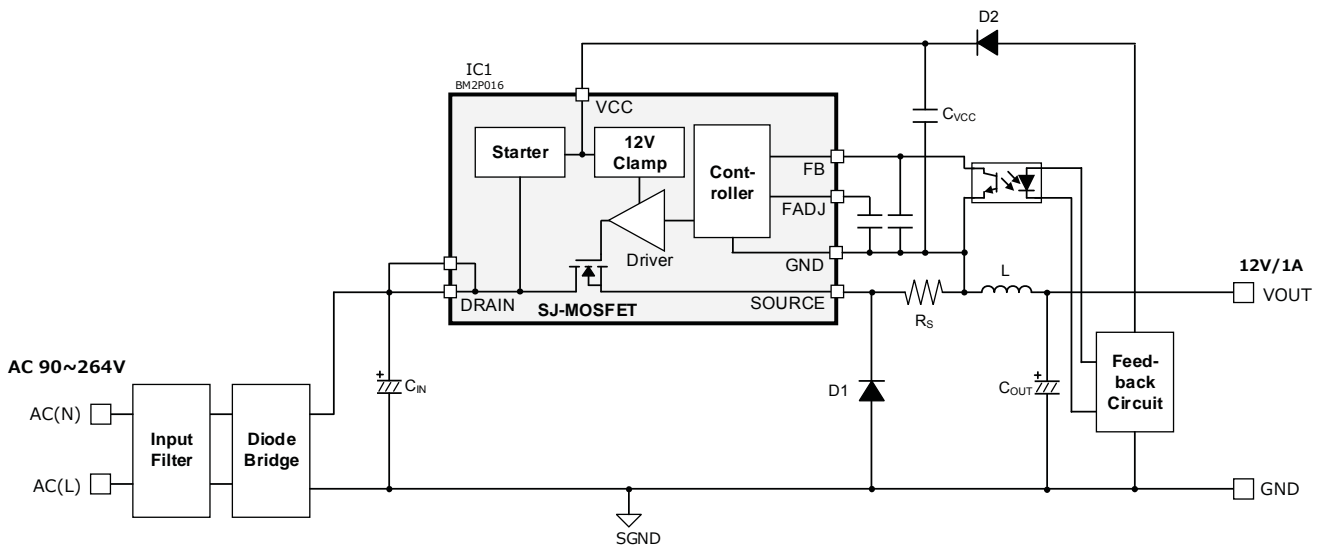

Figure 4. BM2P016-EVK-002 Application Circuit

Non-isolated buck converter method. The output voltage is monitored by a feedback circuit and fed back to the FB terminal through a photo coupler. At startup, the VCC voltage is charged from the DRAIN pin through the Starter circuit. The switching operation starts when the VCC voltage reaches the UVLO release voltage 13.5 V typ.

BM2P016 Overview

Feature

- PWM frequency : 65 kHz
- PWM current mode method
- Frequency hopping function
- Burst operation at light load
- Frequency reduction function
- Built-in 650V start circuit
- Built-in 650V switching MOSFET
- VCC pin under voltage protection
- VCC pin over voltage protection
- SOURCE pin Open protection
- SOURCE pin Short protection
- SOURCE pin Leading-Edge-Blanking function
- Per-cycle over current protection circuit
- AC Correction function of over current limiter
- Soft Start Function
- Secondary over current protection circuit

Key specifications

- Operation Voltage Range: VCC: 8.9 V ~ 26.0 V
DRAIN: 650 V(Max)
- Normal Operating Current: 0.95 mA(Typ)
- Burst Operating Current: 0.30 mA(Typ)
- Oscillation Frequency: 65 kHz(Typ)
- Operating Temperature: -40 °C ~ +105 °C
- MOSFET Ron: 1.4 Ω(Typ)

Application

AC adapters and household appliance (vacuum cleaners, humidifiers, air cleaners, air conditioners, IH cooking heaters, rice cookers, etc.)

Dimension

W(Typ) x D(Typ) x H(Max)

DIP7

9.20 mm x 6.35 mm x 4.30 mm

Pitch 2.54 mm



Figure 5. DIP7 Package

(*) Product structure: Monolithic integrated circuit mainly made of silicon. No radiation resistant design

(*) Exceeding the absolute maximum ratings, such as applied voltage and operating temperature range, may lead to deterioration or destruction. Also, the short mode or open mode cannot assume the destruction state. If a special mode that exceeds the absolute maximum rating is assumed, Please consider physical safety measures such as fuses.

Table 1. BM2P016 PIN description

No.	Name	I/O	Function	ESD Diode	
				VCC	GND
1	SOURCE	I/O	MOSFET SOURCE pin	✓	✓
2	FADJ	I	MAX burst frequency setting pin	✓	✓
3	GND	I/O	GND pin	✓	-
4	FB	I	Feed-back signal input pin	✓	✓
5	VCC	I	Power supply input pin	-	✓
6	DRAIN	I/O	MOSFET DRAIN pin	-	-
7	DRAIN	I/O	MOSFET DRAIN pin	-	-

Design Overview

1 Important parameter

- V_{IN} : Input Voltage Range AC 90 V ~ 264 Vac (DC 100 V ~ 380 V)
- V_{OUT} : Output Voltage DC 12 V
- $I_{OUT}(typ)$: Constant Output Current 1 0.50 A
- $I_{OUT}(typ)$: Constant Output Current 2 0.67 A
- $I_{OUT}(max)$: Maximum Output Current 1.00 A
- f_{sw} : Max Switching Frequency min:60 kHz, typ:65 kHz, max:70 kHz

There are three types of coil operation modes:

- CCM (Continuous Current Mode) : The primary side switching element is turned on before the charging current of the secondary side coil is completely discharged. Since the coil current is continuous.
- BCM (Boundary Current Mode) : The switching element on the primary side is turned on at the same time the discharge of the coil on the secondary side is completed.
- DCM (Dis-continuous Current Mode) : The primary side switching element turns on after the secondary side coil is completely discharged. It is called current discontinuous mode because the coil current is not continuous.

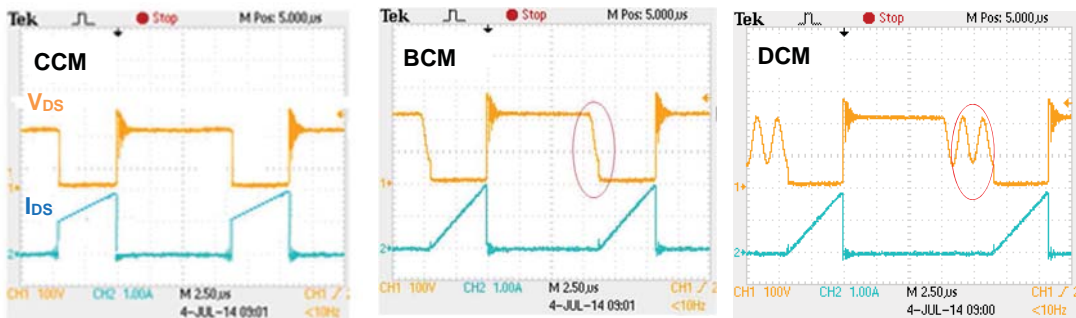

Figure 6. Switching Waveform (MOSFET V_{ds} , I_{ds})

Design Overview - Continued

2 Selection of Coil

2.1 Calculation of inductor

The switching operation mode determines the L value to be in discontinuous mode (DCM) as much as possible. In the case of continuous mode (CCM), the reverse current flows between the diode trr, which causes the diode loss to increase. Furthermore, this reverse current becomes the peak current when the MOSFET is ON, and the loss of the MOSFET also increases. Calculate the L value to be in boundary mode (BCM) at constant load current.

The steady-state load current I_{OUT} (Typ): 0.5 A, and the peak current I_P flowing through the inductor is

$$I_P(BCM) = I_{OUT}(typ) \times 2 = 1.0 \text{ [A]}$$

When the input voltage drops, it tends to be in continuous mode (CCM). Calculate under the condition that the minimum voltage of input voltage $V_{IN}(min) = 100 \text{ Vdc}$. Output voltage $V_{OUT} = 12 \text{ V}$. Calculate the maximum value of Duty: Duty (max) from $V_{OUT} = 12 \text{ V}$ and diode $V_F = 1 \text{ V}$.

$$Duty(max) = \frac{V_{OUT} + V_F}{V_{IN}(min)} = 0.13$$

From the switching frequency minimum value $f_{sw}(min) = 60 \text{ kHz}$, calculate the on time $t_{on}(max)$.

$$t_{on}(Max) = \frac{Duty(max)}{f_{sw}(min)} = 2.17 \text{ [\mu sec]}$$

Calculate the L value to operate in discontinuous mode.

$$L < t_{on}(Max) \times \frac{V_{IN}(min) - V_{OUT}}{I_P} = 191.0 \text{ [\mu H]}$$

In EVK, the L value is tentatively selected 220 μH in consideration of versatility.

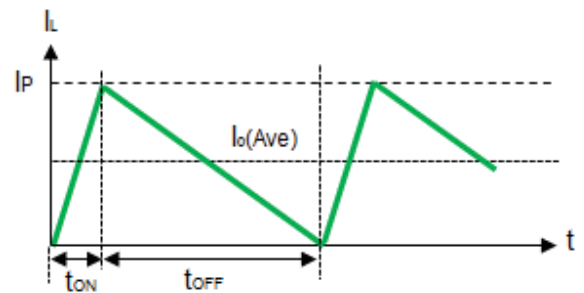

Figure 7. Coil current waveform in boundary mode

Design Overview - Continued

2.2 Calculation of inductor current

The value of current flowing through the coil is maximum when the input voltage is maximum. Operates with the minimum ON time when the input voltage is maximum $V_{IN(max)}$: 380 V. The maximum ON time is about 0.6 to 1.2 μsec depending on the conditions such as the output voltage and L value of the coil. The maximum peak current $I_P(max)$ is

$$I_P(max) = t_{ON(min)} \times \frac{V_{IN(max)} - V_{OUT}}{L} = 0.9 \mu\text{s} \times \frac{380 \text{ V} - 12 \text{ V}}{220 \mu\text{H}} = 1.51 \text{ [A]}$$

Therefore, the inductor to be selected should have an inductor current of 1.5 A or more. The inductor current is checked on the actual device to confirm that magnetic saturation does not occur.

In this EVK, use an inductance value of 220 μH and an allowable current of 1.6 A.

Radial Inductor (Closed Magnetic Type) Core Size $\Phi 9.0 \text{ mm} \times 11.0 \text{ mm}$

Product Name: XE1501Y-221

Manufacturer: Alpha transformer Co., Ltd

3. Selection of current detection resistor R_S (R_1 , R_2)

The current detection resistance R_S (R_1 , R_2) is calculated so that the overcurrent detection becomes maximum load current I_{OUT} : 1000 mA or more. Set the load current I_{LIM} for overcurrent detection to be I_{LIM} : 1200 mA with a 20% margin. When over current is detected, switching operation is performed in continuous mode.

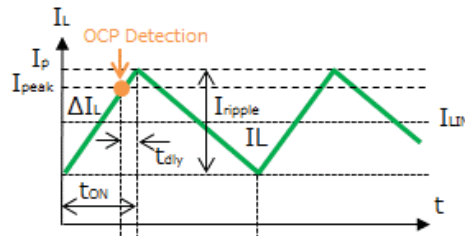

Figure 8. Coil waveform at overcurrent detection (in continuous mode)

The coil current I_{PEAK} at the time of over current detection is calculated by the following formula. Overcurrent detection turns off after a delay time t_{dly} after coil current is detected by I_{PEAK} current.

$$I_{LIM} = I_P - \frac{I_{ripple}}{2}$$

$$I_P = I_{PEAK} + \frac{V_{IN}}{L} \times t_{dly}$$

$$I_{ripple} = \Delta I_L \times t_{ON} = \frac{V_{IN}}{L} \times \frac{Duty}{f_{SW}} = \frac{V_{OUT} + V_F}{L \times f_{SW}}$$

3 Selection of current detection resistor - Continued

$$I_{LIM} = I_{PEAK} + \frac{V_{IN}(min)}{L} - \frac{1}{2} \times \frac{V_{OUT} + V_F}{L \times f_{SW}(min)}$$

The coil current at the time of over current detection is as follows.

$$I_{PEAK} = I_{LIM} - \frac{V_{IN}}{L} \times t_{dly} + \frac{V_{OUT} + V_F}{2 \times L \times f_{SW}(min)} = 1.2 \text{ A} - \frac{100 \text{ V}}{220 \mu\text{H}} \times 0.1 \mu\text{s} + \frac{12 \text{ V} + 1 \text{ V}}{2 \times 220 \mu\text{H} \times 60 \text{ kHz}} = 1.65 \text{ [A]}$$

The time t_{ON} at which the IC detects an overcurrent is

$$t'_{ON} = \frac{Duty(max)}{f_{SW}(min)} = \frac{V_{OUT} + V_F}{V_{IN}(min) \times f_{SW}(min)} - t_{dly} = \frac{12 \text{ V} + 1 \text{ V}}{100 \text{ V} \times 60 \text{ kHz}} - 0.1 \mu\text{s} = 2.07 \text{ [}\mu\text{sec]}$$

AC voltage compensation function is built into overload protection, and the difference of the overload protection point is compensated by the difference of input voltage (100 Vac, 200 Vac, etc). This function is an AC voltage correction function by increasing the over current limiter level V_{CS_LIM} with time.

The overcurrent detection voltage $V_{SOURCE} = 0.4 \text{ V}$, the correction coefficient K_{SOURCE} is $20 \text{ mV} / \mu\text{s}$, and the voltage V_{CS_LIM} of the SOURCE pin at the time of overcurrent detection is

$$V_{CS_LIM} = V_{SOURCE} + t_{ON} \times K_{SOURCE} = 0.4 \text{ V} + 2.07 \mu\text{s} \times 20 \text{ mV} / \mu\text{s} = 441.4 \text{ mV}$$

The sense resistance R_S is as follows.

$$R_S < \frac{V_{CS_LIM}}{I_{PEAK}} = \frac{441.4 \text{ mV}}{1.65 \text{ A}} = 0.267 \Omega$$

In this EVK, R1 and R2 have two 0.47Ω in parallel, and R_S is 0.235Ω . The overload protection point needs to be checked in the board.

Voltage V_R applied to sense resistors R1 and R2 is

$$V_R = \frac{I_P}{2} \times R1 = \frac{1}{2} \times \left(I_{PEAK} + \frac{V_{IN}}{L} \times t_{dly} \right) \times R1 = 0.5 \times \left(1.65 \text{ A} + \frac{100 \text{ V}}{220 \mu\text{H}} \times 0.1 \mu\text{s} \right) \times 0.47 \Omega = 0.398 \text{ V}$$

Power loss P_R of sense resistors R1 and R2 is

$$P_R = I_P(rms)^2 \times R_S = \left(I_P \times \sqrt{\frac{Duty}{3}} \right)^2 \times R_S = \left(1.70 \text{ A} \times \sqrt{\frac{0.13}{3}} \right)^2 \times 0.235 \Omega = 29.4 \text{ [mW]}$$

The resistors used are the MCR18 series, with a maximum device voltage of 1.51 V and a rated power of 0.25 W.

Design Overview - Continued

4 Selection of diode

4.1 Flywheel diode: D1

Flywheel diodes use high-speed diodes (fast recovery diodes). The reverse voltage applied to the diode is V_{IN} (Max): 380 V when the output voltage at startup is 0 V. Ensure derating and select 600 V withstand voltage product.

The conditions for maximum diode effective current are when the input voltage is maximum voltage V_{IN} (max): 380 V, maximum load current I_{OUT} (Max): 1.0 A, and the switching frequency is a minimum of 60 kHz.

The peak current I_P at this time is calculated. The ripple current I_{ripple} is as follows.

$$I_{ripple} = \frac{di}{dt} \times t_{ON} = \frac{\{V_{IN(max)} - (V_{OUT} + V_F)\}}{L} \times \frac{(V_{OUT} + V_F)}{V_{IN(max)} \times f_{SW(min)}}$$

Applying to the peak current formula,

$$I_P = I_{OUT(max)} + \frac{I_{ripple}}{2} = 1.0 \text{ A} + \frac{1}{2} \times \frac{380 \text{ V} - (12 \text{ V} + 1 \text{ V})}{220 \mu\text{H}} \times \frac{12 \text{ V} + 1 \text{ V}}{380 \text{ V} \times 60 \text{ kHz}} = 1.48 \text{ [A]}$$

$$\text{Duty} = \frac{V_{OUT} + V_F}{V_{IN(max)}} = \frac{12 \text{ V} + 1 \text{ V}}{380 \text{ V}} = 3.4 \text{ [%]}$$

The average current I_D of the diode is from peak current I_P : 1.48 A

$$I_D(rms) = I_P \times \sqrt{\frac{1 - \text{Duty}}{3}} = 1.48 \text{ A} \times \sqrt{\frac{1 - 0.034}{3}} = 0.84 \text{ [A]}$$

Select a rated current of 0.84 A or more.

In practice, the 3A / 600V RFN3BM6S is used in consideration of board mounting and component heat generation.

4.2 VCC rectifier diode: D2

The diode supplying VCC uses a rectifying diode. The reverse voltage applied to the diode is V_{IN} (Max): 380V. Ensure derating and select 600 V withstand voltage product. Because the current flowing to the IC is small enough, we use the 0.2 A / 600 V RRE02VSM6S.

Design Overview - Continued

5 Selection of capacitor

5.1 Input Capacitor: C3

The input capacitor is determined by the input voltage V_I and the output power P_{OUT} . As a guide, for an input voltage of 90 to 264 Vac, $2 \times P_{OUT}$ [W] μ F. In the case of 176 to 264 Vac, it is $1 \times P_{OUT}$ [W] μ F. Since the output power $P_{OUT} = 12.0$ W, use 33μ F / 450 V with a standard of 24.0 μ F.

5.2 VCC Capacitor: C7

VCC capacitor C7 is necessary for stable operation of the IC and stable feedback of the output voltage. We recommend 1.0 μ F to 22 μ F at a withstand voltage of 25 V or more. I am using 10 μ F / 35 V.

5.3 Output Capacitor: C8, C9

The output capacitor should be 25 V or more in consideration of derating for the output voltage V_O . The C2 electrolytic capacitor needs to consider the capacitance, impedance and rated ripple current. The output ripple voltage is the combined waveform generated by the ripple current of inductor current: ΔI_L flowing into the output capacitor and the capacitance: C_{out} , impedance: ESR, and is expressed by the following formula.

$$\Delta V_{ripple} = \Delta I_L \times \left(\frac{1}{8 \times C_{out} \times f_{sw}} \right) + ESR$$

Inductor current ripple current: I_L , DC current: I_{DC}

$$\Delta I_L = 2 \times \{I_P - I_{OUT(max)}\} = 2 \times (1.48 - 1.00) = 0.96 \text{ [A]} \quad I_{DC} = I_P - \Delta I_L = 1.48 \text{ A} - 0.96 \text{ A} = 0.52 \text{ [A]}$$

In this EVK, using capacitance: 680 μ F, ESR: 0.049 Ω , the design value of the output ripple voltage is 100 mV or less.

$$\Delta V_{ripple} = \Delta I_L \times \left\{ \left(\frac{1}{8 \times C_{out} \times f_{sw}} \right) + ESR \right\} = 0.96 \text{ A} \times \left\{ \left(\frac{1}{8 \times 680 \mu \times 65k} \right) + 0.049 \right\} = 49.8 \text{ [mV]}$$

Next, check if the ripple current of the capacitor satisfies the rated ripple current. Inductor ripple current RMS conversion,

$$I_L[rms] = \Delta I_L \times \sqrt{\frac{1}{3}} + I_{DC} = 0.96 \times \sqrt{\frac{1}{3}} + 0.52 \text{ A} = 1.07 \text{ [Arms]}$$

The ripple current of the capacitor is

$$I_C[rms] = \sqrt{I_L^2 - I_{OUT}^2} = \sqrt{1.07^2 - 1.0^2} = 0.381 \text{ [A]}$$

Select a rated current of 0.381 A or more. The output capacitor C8 used rated ripple current 1.24 A at 680 μ F / 25 V. C9 adds a 0.1 μ F ceramic capacitor to reduce switching noise.

Design Overview - Continued

6 Output voltage setting resistor: R6,R7,R8

The output voltage is set by the following formula.

$$V_{OUT} = \left(1 + \frac{R6 + R7}{R8}\right) \times V_{ref}$$

Set the feedback current I_{BIAS} flowing to R8 at 0.1 mA to 1.0 mA.

Assuming that $I_{BIAS} = 0.25 \text{ mA}$, and the reference voltage

$V_{REF} = 2.485 \text{ V}$ of the shunt regulator IC2, the resistance value of R8 is

$$R8 = \frac{V_{REF}}{I_{BIAS}} = \frac{2.485 \text{ V}}{0.25 \text{ mA}} = 9.9 \text{ [k}\Omega\text{]}$$

In this EVK, select R8: 10 kΩ.

The combined resistance of the feedback resistors (R6+R7+R8) is

$$R6 + R7 + R8 = \frac{V_{OUT}}{I_{BIAS}} = \frac{12 \text{ V}}{0.25 \text{ mA}} = 48 \text{ [k}\Omega\text{]}$$

In this EVK, R6 = 33 kΩ and R7 = 5.6 kΩ are selected. The theoretical value of the output voltage is as follows.

$$V_{OUT} = \left(1 + \frac{33 \text{ k}\Omega + 5.6 \text{ k}\Omega}{10 \text{ k}\Omega}\right) \times 2.485 \text{ V} = 12.08 \text{ V}$$

7 Control circuit adjustment: R9,R10,R11,C10

R10 is the dark current setting resistor for shunt regulator IC2. The current value I_{min} for stable operation of the shunt regulator is 1.2 mA according to the data sheet of the IC. This current is the combined current of R10 and the photo coupler's I_F . Since the voltage applied to R10 is the V_F of the photo coupler, assuming that the V_F of the photo coupler is 1.1 V,

$$R10 < \frac{V_F}{I_{min}} = \frac{1.1 \text{ V}}{1.2 \text{ mA}} = 0.92 \text{ [k}\Omega\text{]}$$

In this EVK, select R10 = 1.0 kΩ.

R9 is the control circuit current limiting resistor. Adjust with 300 to 2.2 kΩ.

In this EVK, select R9 = 1.0 kΩ.

R11 and C10 are phase compensation circuits. Adjust R11 = 1 k-30 kΩ, C10 = 0.1 μF or so with the actual device.

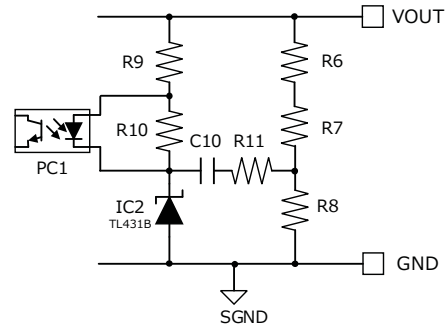

Figure 9. Feed-back Circuit

Performance Data

Load Regulation

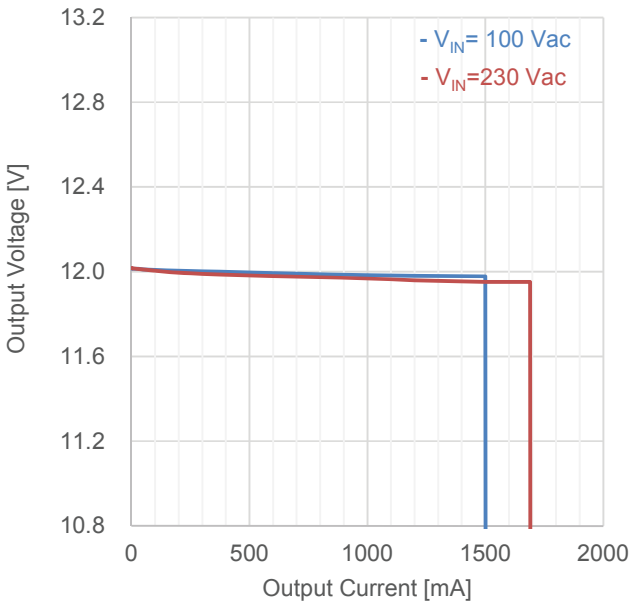

Figure 10. Load Regulation (I_{OUT} vs V_{OUT})

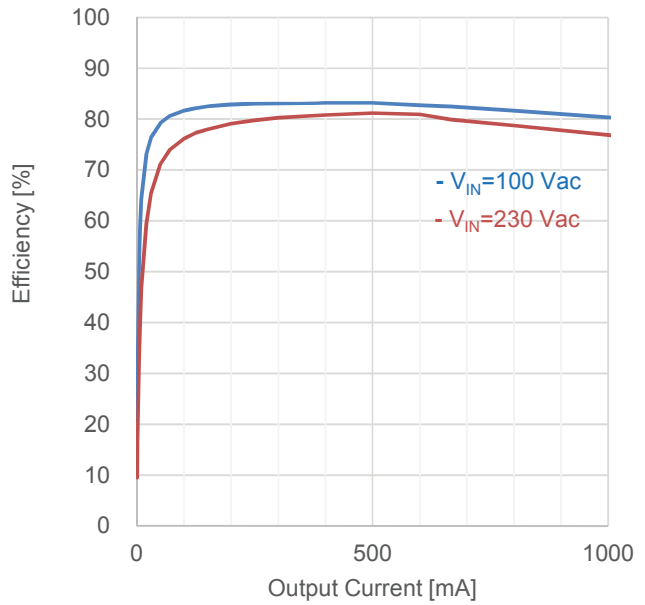

Figure 11. Load Regulation (I_{OUT} vs Efficiency)

Table 2. Load Regulation ($V_{IN}=100$ Vac)

I_{OUT}	V_{OUT}	Efficiency
250 mA	12.003 V	82.99 %
500 mA	11.997 V	83.20 %
667 mA	11.991 V	82.45 %
1000 mA	11.984 V	80.32 %

Table 3. Load Regulation ($V_{IN}=230$ Vac)

I_{OUT}	V_{OUT}	Efficiency
250 mA	11.993 V	79.78 %
500 mA	11.982 V	81.18 %
667 mA	11.978 V	79.89 %
1000 mA	11.967 V	76.91 %

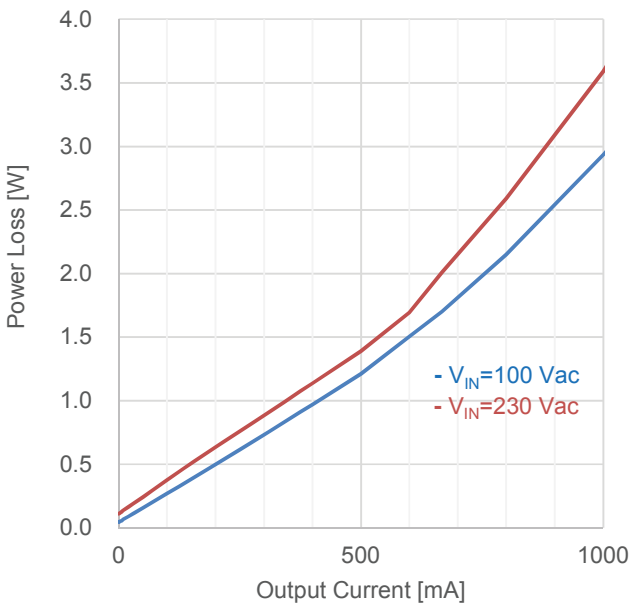

Figure 12. Load Regulation (I_{OUT} vs P_{LOSS})

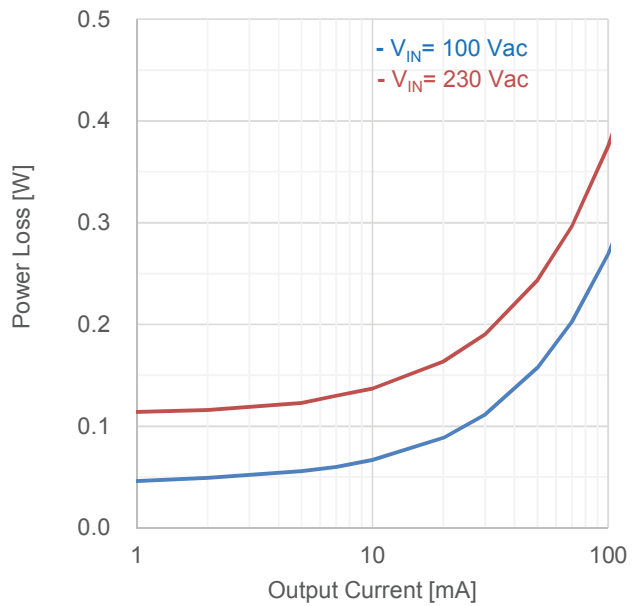

Figure 13. Load Regulation (I_{OUT} vs P_{LOSS})

Performance Data – Continued

Table 4. Load Regulation: V_{IN}=100 Vac

V _{IN} [Vac]	P _{IN} [W]	V _{OUT} [V]	I _{OUT} [mA]	P _{OUT} [W]	P _{LOSS} [W]	Efficiency [%]
100	0.044	12.015	0	0.000	0.044	0.00
100	0.058	12.015	1	0.012	0.046	20.72
100	0.073	12.015	2	0.024	0.049	32.92
100	0.116	12.015	5	0.060	0.056	51.79
100	0.144	12.014	7	0.084	0.060	58.40
100	0.187	12.014	10	0.120	0.067	64.25
100	0.329	12.013	20	0.240	0.089	73.03
100	0.472	12.013	30	0.360	0.112	76.35
100	0.758	12.011	50	0.601	0.157	79.23
100	1.043	12.009	70	0.841	0.202	80.60
100	1.470	12.008	100	1.201	0.269	81.69
100	1.827	12.007	125	1.501	0.326	82.15
100	2.183	12.006	150	1.801	0.382	82.50
100	2.899	12.004	200	2.401	0.498	82.81
100	3.616	12.003	250	3.001	0.615	82.99
100	4.334	12.002	300	3.601	0.733	83.08
100	5.413	12.000	375	4.500	0.913	83.13
100	5.771	11.999	400	4.800	0.971	83.17
100	7.21	11.997	500	5.999	1.212	83.20
100	8.70	11.993	600	7.196	1.504	82.71
100	9.70	11.991	667	7.998	1.702	82.45
100	11.74	11.988	800	9.590	2.150	81.69
100	14.92	11.984	1000	11.984	2.936	80.32
100	18.17	11.981	1200	14.377	3.793	79.13
100	23.44	11.978	1500	17.967	5.473	76.65
100	0.06	0.000	1510	0.000	0.063	0.00

Table 5. Load Regulation: V_{IN}=230 Vac

V _{IN} [Vac]	P _{IN} [W]	V _{OUT} [V]	I _{OUT} [mA]	P _{OUT} [W]	P _{LOSS} [W]	Efficiency [%]
230	0.111	12.017	0	0.000	0.111	0.00
230	0.126	12.016	1	0.012	0.114	9.54
230	0.140	12.016	2	0.024	0.116	17.17
230	0.183	12.016	5	0.060	0.123	32.83
230	0.214	12.015	7	0.084	0.130	39.30
230	0.257	12.015	10	0.120	0.137	46.75
230	0.404	12.014	20	0.240	0.164	59.48
230	0.551	12.013	30	0.360	0.191	65.41
230	0.844	12.010	50	0.601	0.244	71.15
230	1.137	12.008	70	0.841	0.296	73.93
230	1.576	12.005	100	1.201	0.376	76.17
230	1.941	12.002	125	1.500	0.441	77.29
230	2.307	11.999	150	1.800	0.507	78.02
230	3.034	11.995	200	2.399	0.635	79.07
230	3.758	11.993	250	2.998	0.760	79.78
230	4.483	11.990	300	3.597	0.886	80.24
230	5.571	11.987	375	4.495	1.076	80.69
230	5.931	11.986	400	4.794	1.137	80.84
230	7.38	11.982	500	5.991	1.389	81.18
230	8.88	11.979	600	7.187	1.693	80.94
230	10.00	11.978	667	7.989	2.011	79.89
230	12.17	11.974	800	9.579	2.591	78.71
230	15.56	11.967	1000	11.967	3.593	76.91
230	19.19	11.959	1200	14.351	4.839	74.78
230	24.84	11.952	1500	17.928	6.912	72.17
230	29.16	11.952	1690	20.199	8.961	69.27
230	0.19	0.000	1700	0.000	0.192	0.00

Performance Data – Continued

Line Regulation

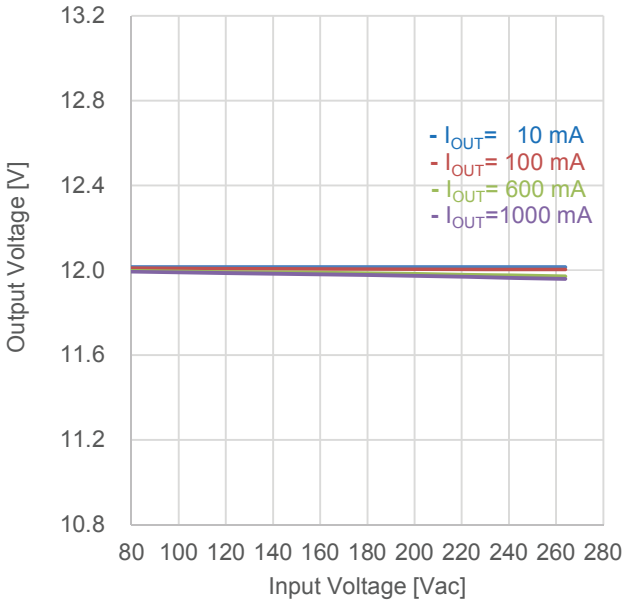

Figure 14. Line Regulation (V_{IN} vs V_{OUT})

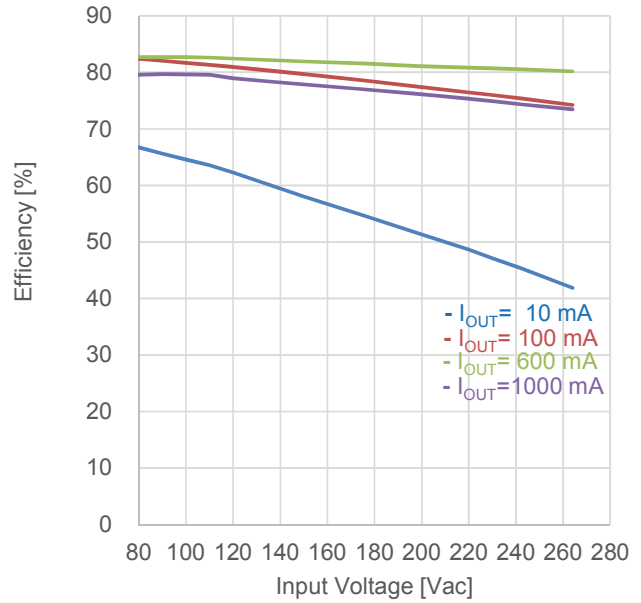

Figure 15. Line Regulation (V_{IN} vs Efficiency)

Switching Frequency

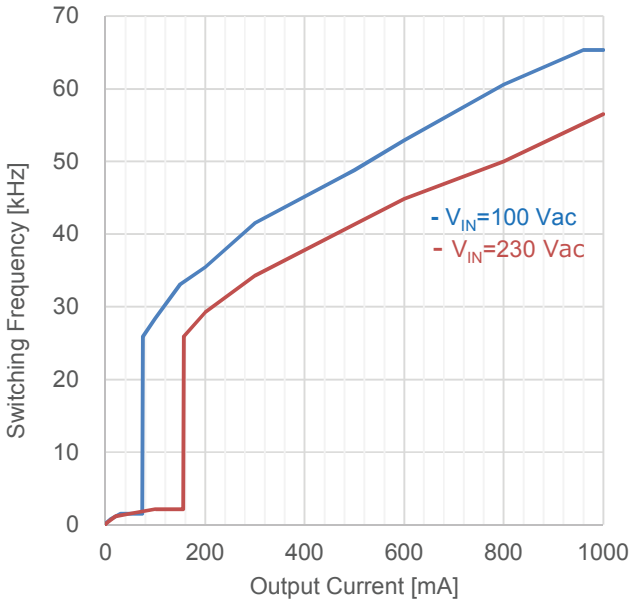

Figure 16. Switching Frequency (I_{OUT} vs f_{sw})

Coil Peak Current

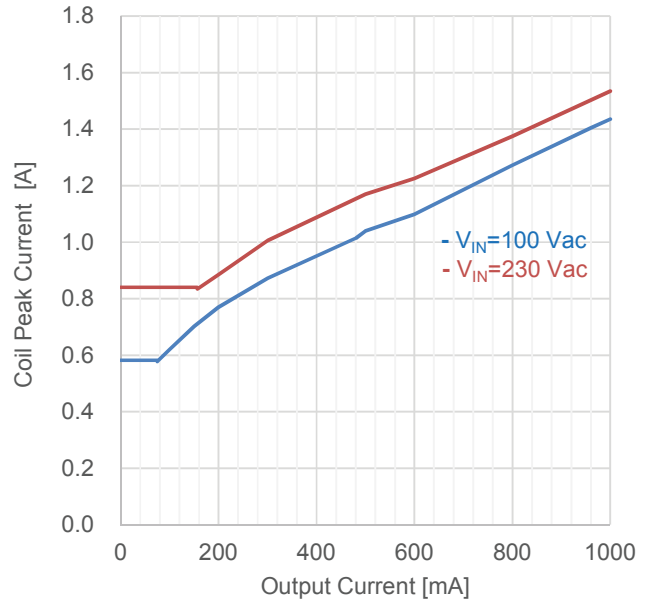

Figure 17. Coil Peak Current (I_{OUT} vs I_p)

Performance Data – Continued

Output Ripple Voltage

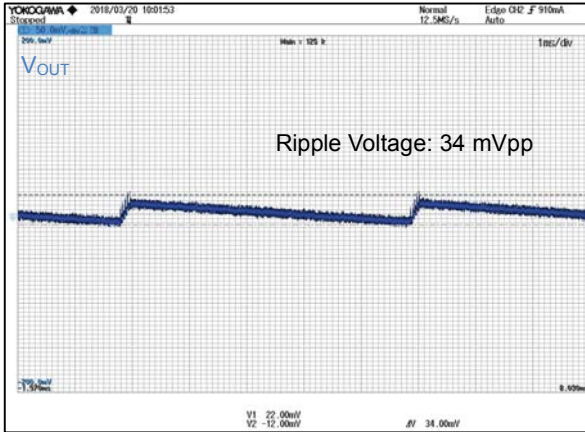

Figure 18. $V_{IN} = 100 \text{ Vdc}$, $I_{OUT} = 10 \text{ mA}$

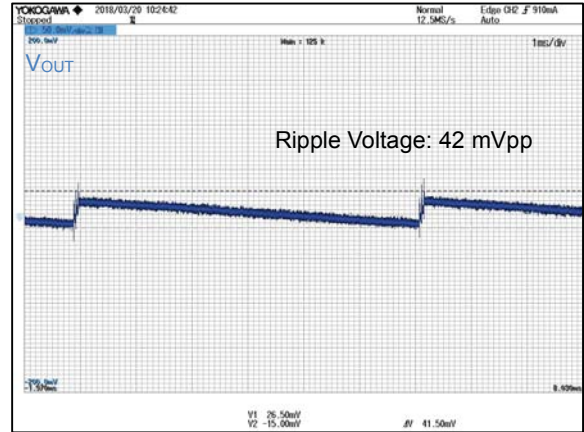

Figure 19. $V_{IN} = 230 \text{ Vac}$, $I_{OUT} = 10 \text{ mA}$

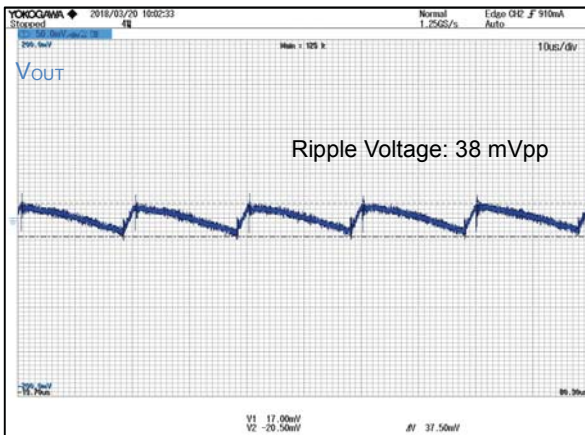

Figure 20. $V_{IN} = 100 \text{ Vac}$, $I_{OUT} = 500 \text{ mA}$

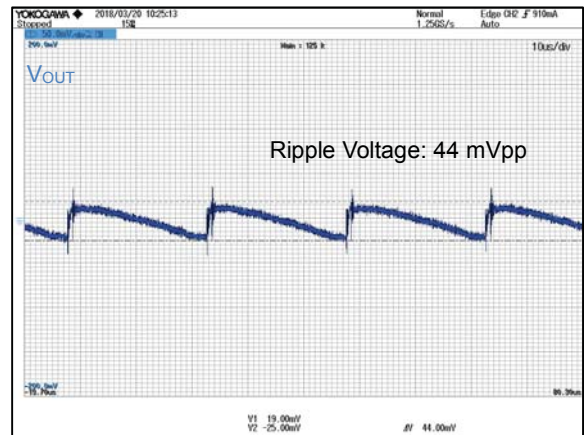

Figure 21. $V_{IN} = 230 \text{ Vac}$, $I_{OUT} = 500 \text{ mA}$

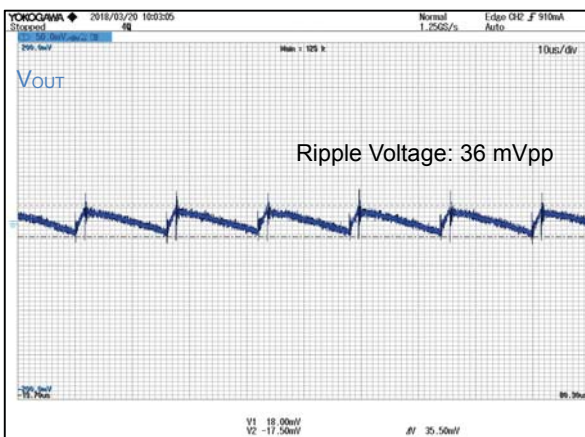

Figure 22. $V_{IN} = 100 \text{ Vac}$, $I_{OUT} = 1000 \text{ mA}$

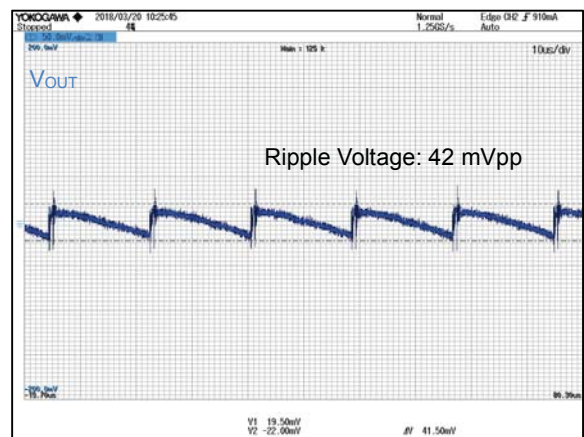

Figure 23. $V_{IN} = 230 \text{ Vac}$, $I_{OUT} = 1000 \text{ mA}$

Performance Data – Continued

Parts surface temperature

Table 6. Parts surface temperature Ta = 25 °C, measured 30minutes after startup

Part	Condition			
	V _{IN} =90 Vac, I _{OUT} =0.50 A	V _{IN} =90 Vac, I _{OUT} =0.67 A	V _{IN} =264 Vac, I _{OUT} =0.50 A	V _{IN} =264 Vac, I _{OUT} =0.67 A
IC1	43.7 °C	62.9 °C	50.4 °C	75.7 °C
D1	53.3 °C	74.5 °C	60.5 °C	79.7 °C
L1	37.4 °C	56.1 °C	47.6 °C	61.2 °C

EMI

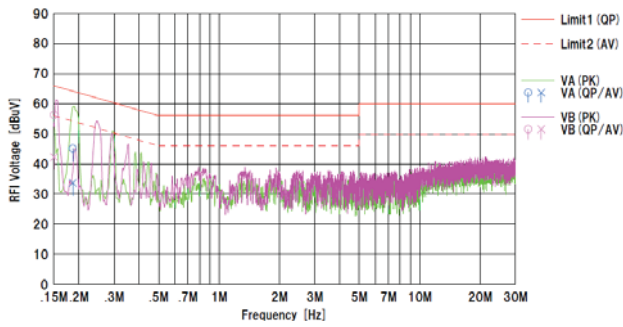

Figure 24. Conducted Emission.1
 VIN=110 Vac/60 Hz, IOUT= 0.5 A
 QP margine : 9.6 dB, AV margine=13.6dB

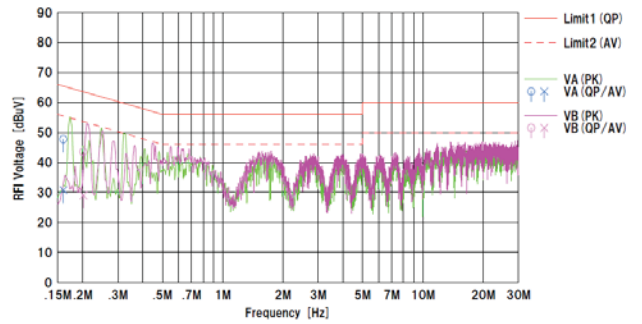

Figure.25 Conduction Emission.2
 VIN=230 Vac/50 Hz, IOUT= 0.5 A
 QP margine : 17.7 dB, AV margine=24.5 dB

Schematics

V_{IN} = 90 ~ 264 Vdc, V_{OUT} = 12 V

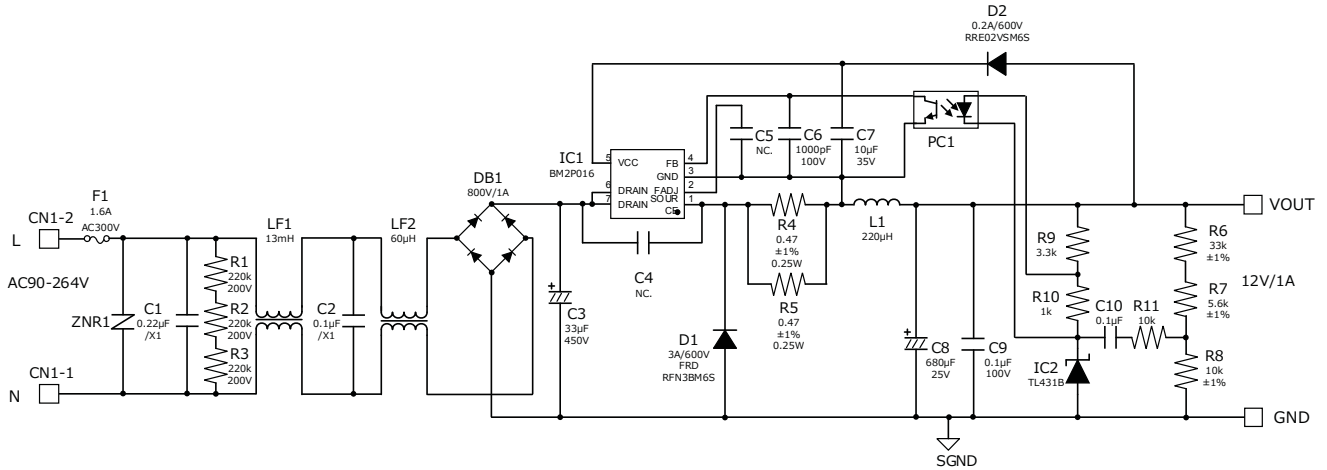

Figure 26. BM2P016-EVK-002 Schematics

Bill of Materials

Table 7. BoM of BM2P016-EVK-002

Part Reference	Qty.	Type	Value	Description	Part Number	Manufacture	Configuration mm (inch)
C1	1	Film	0.22µF	X2	890324023028CS	Würth	-
C2	1	Film	0.1µF	X2	890324023023CS	Würth	-
C3	1	Electrolytic	33µF	450V	450BXW33MEFR12.5X25	Rubycon	-
C4	0	Ceramic	47pF	1000V, X7R, ±10%	RDER73A470J2K1H03B	Murata	-
C5	0	Ceramic	-	-	-	-	1608 (0603)
C6	1	Ceramic	1000pF	100V, X7R, ±20%	HMK107B7102MA-T	Taiyo Yuden	1608 (0603)
C7	1	Ceramic	10µF	35V, X7R, ±20%	GMK316AB7106ML-TR	Taiyo Yuden	3216 (1206)
C8	1	Electrolytic	680µF	25V, Low-Z	UPA1E681MPD	Nichicon	-
C9,C10	2	Ceramic	0.1µF	100V, X7R, ±20%	HMK107B7104MA-T	Taiyo Yuden	1608 (0603)
CN1	1	Connector	-	2pin	B2P-NV	JST	-
D1	1	FRD	3A	600V	RFN3BM6S	ROHM	TO-252
D2	1	Diode	0.2A	600V	RRE02VSM6S	ROHM	TUMD2SM
DB1	1	Bridge	1A	800V	D1UBA80	Shindengen	SOPA-4
F1	1	Fuse	1.6A	300Vac	36911600000	LittleFuse	-
IC1	1	AC/DC Converter	-	-	BM2P016-Z	ROHM	DIP7
IC2	1	Shunt Regulator	-	±0.5%	TL431BIDBZT	TI	SOT-23-3
L1	1	Coil	220µH	1.9A	XF1501Y-221	Alpha Trans	Φ13.5
LF1	1	Line Filter	13mH	1A	XF1482Y	Alpha Trans	-
LF2	1	Line Filter	60µH	1A	LF1246Y	Alpha Trans	-
PC1	1	Optocoupler	-	5kV	LTV-817-B	LiteOn	DIP4
R1,R2,R3	3	Resistor	220kΩ	200V, ±5%	MCR18EZPJ224	ROHM	3216 (1206)
R4,R5	2	Resistor	0.47Ω	0.25W, ±1%	MCR18EZHFLR470	ROHM	3216 (1206)
R6	1	Resistor	33kΩ	0.1W, ±1%	MCR03EZPFX3302	ROHM	1608 (0603)
R7	1	Resistor	5.6kΩ	0.1W, ±1%	MCR03EZPFX5601	ROHM	1608 (0603)
R8	1	Resistor	10kΩ	0.1W, ±1%	MCR03EZPFX1002	ROHM	1608 (0603)
R9	1	Resistor	3.3kΩ	0.1W, ±1%	MCR03EZPFX3301	ROHM	1608 (0603)
R10	1	Resistor	1kΩ	0.1W, ±5%	MCR03EZPJ102	ROHM	1608 (0603)
R11	1	Resistor	10kΩ	0.1W, ±5%	MCR03EZPJ103	ROHM	1608 (0603)
ZNR1	1	Varistor	-	470V, 400A	V470ZA05P	LittleFuse	-

PCB

Size : 55 mm x 80 mm

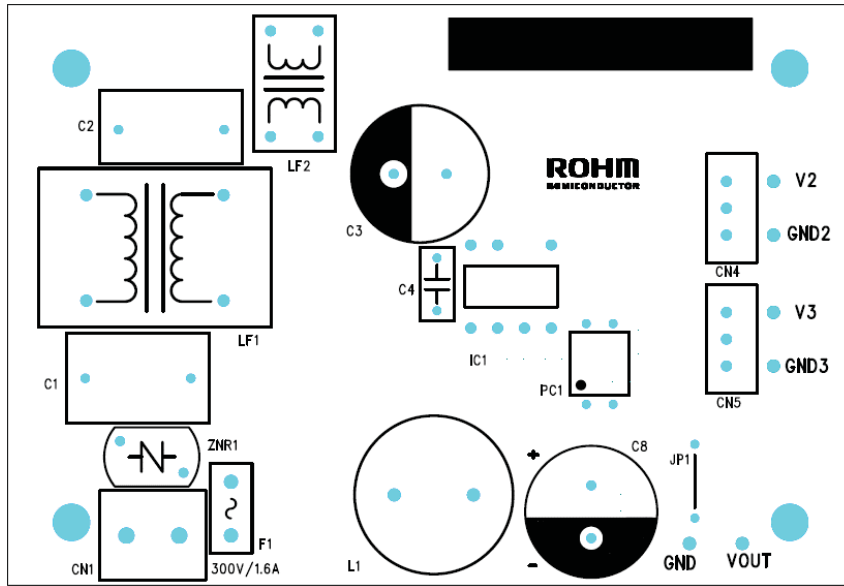

Figure 27. Top Layout (Top view)

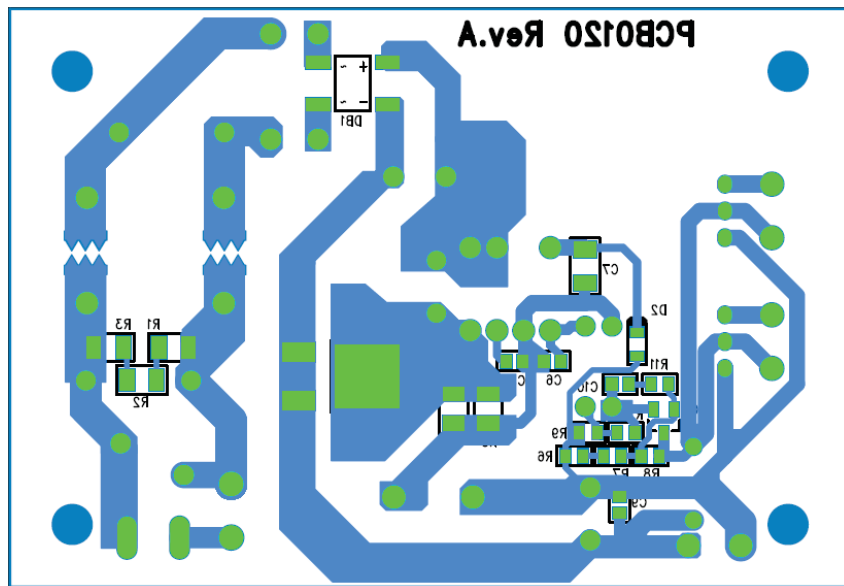

Figure 28. Bottom Layout (Top view)

Notes

- 1) The information contained herein is subject to change without notice.
- 2) Before you use our Products, please contact our sales representative and verify the latest specifications :
- 3) Although ROHM is continuously working to improve product reliability and quality, semiconductors can break down and malfunction due to various factors.
Therefore, in order to prevent personal injury or fire arising from failure, please take safety measures such as complying with the derating characteristics, implementing redundant and fire prevention designs, and utilizing backups and fail-safe procedures. ROHM shall have no responsibility for any damages arising out of the use of our Products beyond the rating specified by ROHM.
- 4) Examples of application circuits, circuit constants and any other information contained herein are provided only to illustrate the standard usage and operations of the Products. The peripheral conditions must be taken into account when designing circuits for mass production.
- 5) The technical information specified herein is intended only to show the typical functions of and examples of application circuits for the Products. ROHM does not grant you, explicitly or implicitly, any license to use or exercise intellectual property or other rights held by ROHM or any other parties. ROHM shall have no responsibility whatsoever for any dispute arising out of the use of such technical information.
- 6) The Products specified in this document are not designed to be radiation tolerant.
- 7) For use of our Products in applications requiring a high degree of reliability (as exemplified below), please contact and consult with a ROHM representative : transportation equipment (i.e. cars, ships, trains), primary communication equipment, traffic lights, fire/crime prevention, safety equipment, medical systems, servers, solar cells, and power transmission systems.
- 8) Do not use our Products in applications requiring extremely high reliability, such as aerospace equipment, nuclear power control systems, and submarine repeaters.
- 9) ROHM shall have no responsibility for any damages or injury arising from non-compliance with the recommended usage conditions and specifications contained herein.
- 10) ROHM has used reasonable care to ensure the accuracy of the information contained in this document. However, ROHM does not warrants that such information is error-free, and ROHM shall have no responsibility for any damages arising from any inaccuracy or misprint of such information.
- 11) Please use the Products in accordance with any applicable environmental laws and regulations, such as the RoHS Directive. For more details, including RoHS compatibility, please contact a ROHM sales office. ROHM shall have no responsibility for any damages or losses resulting non-compliance with any applicable laws or regulations.
- 12) When providing our Products and technologies contained in this document to other countries, you must abide by the procedures and provisions stipulated in all applicable export laws and regulations, including without limitation the US Export Administration Regulations and the Foreign Exchange and Foreign Trade Act.
- 13) This document, in part or in whole, may not be reprinted or reproduced without prior consent of ROHM.



Thank you for your accessing to ROHM product informations.
More detail product informations and catalogs are available, please contact us.

ROHM Customer Support System

<http://www.rohm.com/contact/>