

Features

- Wide Single-supply Voltage Range or Dual Supplies: +2.5 V to +36 V or ± 1.25 V to ± 18 V
- Very Low Supply Current (150 μ A/ch)
- Low Input Bias Current: 1 nA maximum
- Low Offset Voltage: ± 6.0 mV maximum
- Input Common-mode Voltage Range Includes Ground
- Internal Differential Input Voltage Range Equal to The Supply Voltage
- Low Output Saturation
- -40°C to 125°C Operation Range
- ESD Rating: HBM 4 kV, CDM 2 kV

Applications

- High-speed Line or Digital Line Receivers
- High Speed Sampling Circuits
- Peak and Zero-crossing Detectors
- Threshold Detectors/Discriminators
- Sensing at Ground or Supply Line

Description

The devices in this series consist of dual/quad independent single or dual supply voltage comparators on a single monolithic substrate. The common mode input voltage range includes ground even when operated from a single supply, and the low power supply current drain makes these comparators suitable for battery operation. These types were designed to directly interface with TTL and CMOS. Current drain is independent of the supply voltage. The outputs can be connected to other open-collector outputs to achieve wired-AND relationships.

All devices are specified for the temperature range of -40°C to 125°C .

Typical Application Circuit

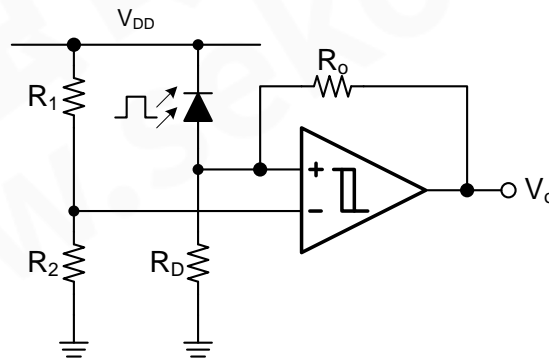

Table of Contents

Features	1
Applications	1
Description	1
Typical Application Circuit	1
Revision History	3
Pin Configuration	4
Specifications	5
Absolute Maximum Ratings ⁽¹⁾	5
ESD, Electrostatic Discharge Protection	5
Thermal Information	5
Electrical Characteristics	6
Typical Performance Characteristics.....	7
Application and Implementation	8
Application Information.....	8
Typical Application	9
Tape and Reel Information	10
Package Outline Dimensions	11
SOP8	11
MSOP8	12
SOP14	13
TSSOP14	14
Order Information	15

Revision History

Date	Revision	Notes
2022-05-05	Rev.A.0	Update new document format. Update package outline dimensions with 3PEAK new POD format, no change on the product. Combine <u>LM2903A</u> , <u>LM2901A</u> to one datasheet. Updated I_{OS} , I_B , I_{DIFF} spec: I_B : add max limit value 1nA at 25 °C, add max limit value 10nA at -40°C to 125°C I_{OS} : add max limit value 1nA at 25 °C, add max limit value 10nA at -40°C to 125°C I_{OS} : add typical value 50nA at 25 °C
2022-05-13	Rev.A.1	Correct typo error in order information: MSL of <u>LM2903AL1-SR</u> : "3" -> "1", no change on the product.

Pin Configuration

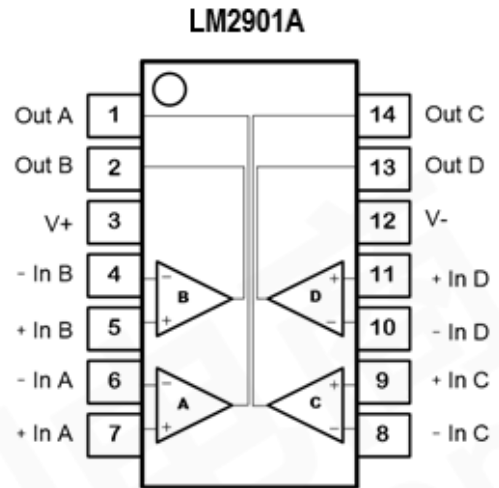
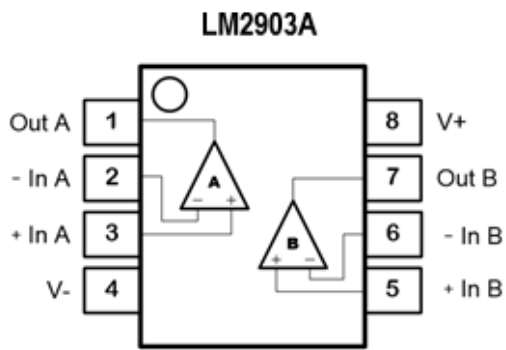

Specifications

Absolute Maximum Ratings ⁽¹⁾

Parameter		Min	Max	Unit
	Supply Voltage: $V^+ - V^-$		42	V
	Input Voltage	$V^- - 0.3$	$V^+ + 0.3$	V
	Input Current: +IN, -IN ⁽²⁾	-20	+20	mA
	Output Current: OUT	-20	+20	mA
	Output Short-Circuit Duration ⁽³⁾		Infinite	
	Current at Supply Pins	-60	+60	mA
T_J	Maximum Junction Temperature		150	°C
T_A	Operating Temperature Range	-40	125	°C
T_{STG}	Storage Temperature Range	-65	150	°C
T_L	Lead Temperature (Soldering 10 sec)		260	°C

(1) Stresses beyond those listed under Absolute Maximum Ratings may cause permanent damage to the device. Exposure to any Absolute Maximum Rating condition for extended periods may affect device reliability and lifetime.

(2) The inputs are protected by ESD protection diodes to each power supply. If the input extends more than 500 mV beyond the power supply, the input current should be limited to less than 10 mA.

(3) A heat sink may be required to keep the junction temperature below the absolute maximum. This depends on the power supply voltage and how many amplifiers are shorted. Thermal resistance varies with the amount of PC board metal connected to the package. The specified values are for short traces connected to the leads.

ESD, Electrostatic Discharge Protection

Symbol	Parameter	Condition	Minimum Level	Unit
HBM	Human Body Model ESD	ANSI/ESDA/JEDEC JS-001 ⁽¹⁾	4	kV
CDM	Charged Device Model ESD	ANSI/ESDA/JEDEC JS-002 ⁽²⁾	2	kV

(1) JEDEC document JEP155 states that 500-V HBM allows safe manufacturing with a standard ESD control process.

(2) JEDEC document JEP157 states that 250-V CDM allows safe manufacturing with a standard ESD control process.

Thermal Information

Package Type	θ_{JA}	θ_{JC}	Unit
SOP8	158	43	°C/W
MSOP8	210	45	°C/W
SOP14	97	47	°C/W
TSSOP14	108	43	°C/W

Electrical Characteristics

All test condition is $V_{CC} = 5\text{ V}$, $R_{PU} = 10\text{ k}\Omega$, $C_L = 15\text{ pF}$, $T_A = 25^\circ\text{C}$, unless otherwise noted.

Symbol	Parameter	Conditions	Min	Typ	Max	Unit
V_{CC}	Supply Voltage	$T_A = -40^\circ\text{C}$ to 125°C	2.5		36	V
V_{OS}	Input Offset Voltage	$V_{CC} = 5\text{ V}$ to 30 V , $V_{CM} = 0\text{ V}$, $V_O = 1.4\text{ V}$, $T_A = -40^\circ\text{C}$ to 125°C	-6	± 0.6	+6	mV
I_B	Input Bias Current ⁽¹⁾	$V_{DM} = 0\text{ V}$, $V_{CM} = 0\text{ V}$		0.1	1	nA
		$V_{DM} = 0\text{ V}$, $V_{CM} = 0\text{ V}$, $T_A = -40^\circ\text{C}$ to 125°C		1	10	nA
I_{OS}	Input Offset Current ⁽¹⁾	$V_{DM} = 0\text{ V}$, $V_{CM} = 0\text{ V}$		0.1	1	nA
		$V_{DM} = 0\text{ V}$, $V_{CM} = 0\text{ V}$, $T_A = -40^\circ\text{C}$ to 125°C		1	10	nA
I_{Diff}	Input Differential Current	$V_{CC} = 36\text{ V}$, $V_{DM} = 36\text{ V}$		50		nA
C_{IN}	Input Capacitance	$T_A = 25^\circ\text{C}$	Differential		2.5	pF
			Common Mode		5	
V_{CM}	Common-mode Input Voltage Range		0		$V_{CC} - 1.5$	V
		$T_A = -40^\circ\text{C}$ to 125°C	0		$V_{CC} - 2$	V
A_{VD}	Large-signal Differential-voltage Amplification	$V_{CC} = 15\text{ V}$, $V_O = 1.4\text{ V}$ to 11.4 V , $R_L \geq 15\text{ k}\Omega$ to V_{CC}	50	400		V/mV
I_{OH}	High-level Output Current	$V_{OH} = 5\text{ V}$, $V_{ID} = 1\text{ V}$		25	200	nA
		$V_{CC} = 36\text{ V}$, $V_{OH} = 36\text{ V}$, $V_{ID} = 1\text{ V}$, $T_A = -40^\circ\text{C}$ to 125°C			7	μA
V_{OL}	Low-Level Output Voltage	$I_{OL} = 4\text{ mA}$, $V_{ID} = -1\text{ V}$		250	400	mV
		$I_{OL} = 4\text{ mA}$, $V_{ID} = -1\text{ V}$, $T_A = -40^\circ\text{C}$ to 125°C			500	mV
I_{OL}	Low-Level Output Current	$V_{OL} = 1.5\text{ V}$, $V_{ID} = -1\text{ V}$	10			mA
I_Q	Quiescent Current per Comparator	$V_{CC} = 5\text{ V}$		150	300	μA
		$V_{CC} = 36\text{ V}$		150	300	μA
t_{RT}	Response Time	R_L connected to 5 V through $5.1\text{ k}\Omega$, $C_L = 15\text{ pF}$	100-mV input step with 5-mV overdrive		2	μs
			TTL-level input step		0.5	

(1) Provided by bench test and design simulation

Typical Performance Characteristics

All test conditions: $V_S = 5\text{ V}$, $V_{CM} = 0\text{ V}$, $R_L = \text{Open}$, unless otherwise noted.

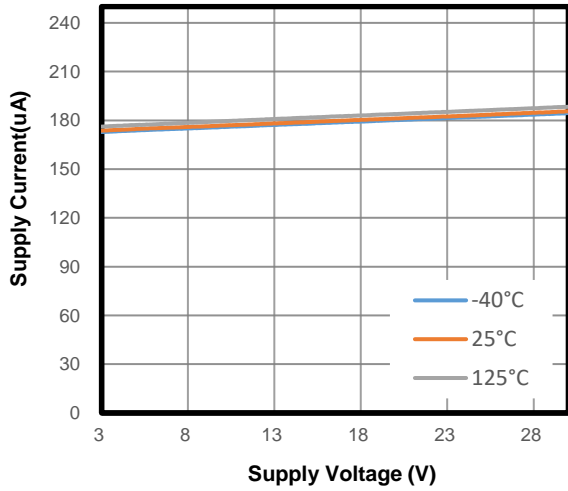

Figure 1. Supply Current vs. Supply Voltage (Dual Channel)

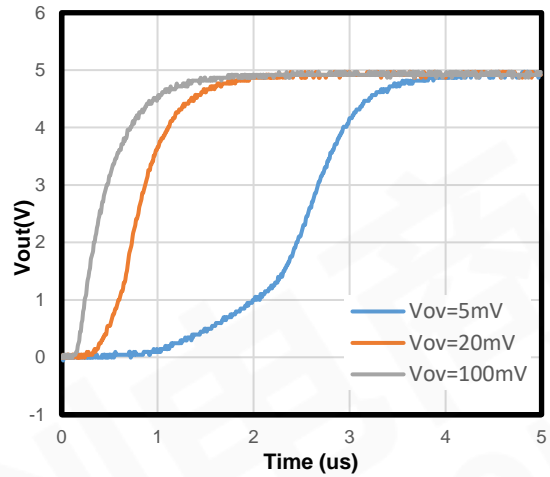

Figure 2. Response Time for Various Input Overdrives: Positive Transition

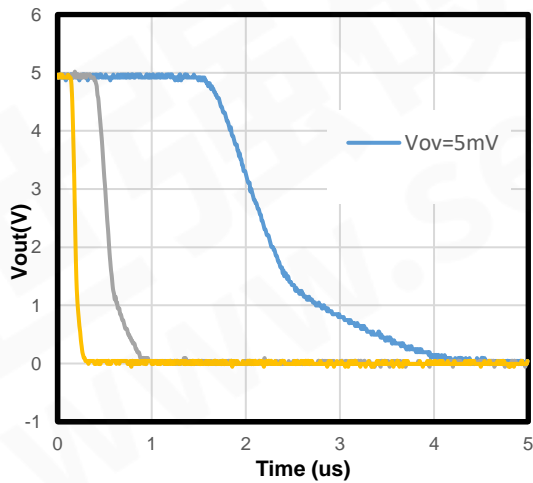

Figure 3. Response Time for Various Input Overdrives: Negative Transition

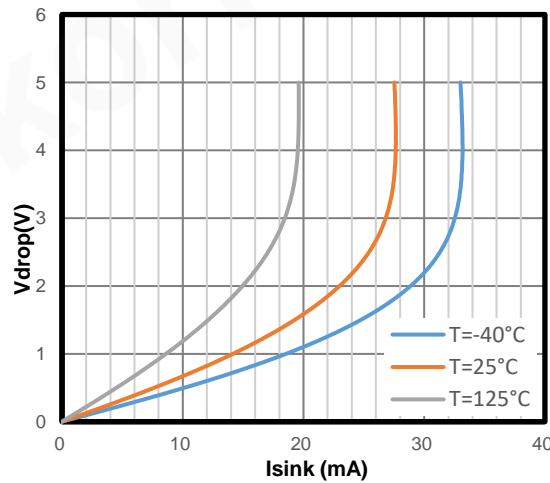

Figure 4 Negative Output Swing vs. Sink Current

Application and Implementation

NOTE

Information in the following applications sections is not part of the 3PEAK's component specification and 3PEAK does not warrant its accuracy or completeness. 3PEAK's customers are responsible for determining suitability of components for their purposes. Customers should validate and test their design implementation to confirm system functionality.

Application Information

Power Supply Layout and Bypass

The LM2903A/2901A family's power supply pin should have a local bypass capacitor (i.e., 0.01 μF to 0.1 μF) within 2mm for good high frequency performance. It can also use a bulk capacitor (i.e., 1 μF or larger) within 100mm to provide large, slow currents. This bulk capacitor can be shared with other analog parts.

Good ground layout improves performance by decreasing the amount of stray capacitance and noise at the comparator's inputs and outputs. To decrease stray capacitance, minimize PCB lengths and resistor leads, and place external components as close to the comparator's pins as possible.

Inputs

The electrostatic discharge (ESD) protection input structure of two back-to-back diodes and 1k Ω series resistors are used to limit the differential input voltage applied to the precision input of the comparator by clamping input voltages that exceed supply voltages, as shown in Figure 5. Large voltage exceeding the supply voltage should be avoided to prevent damage to the input stage.

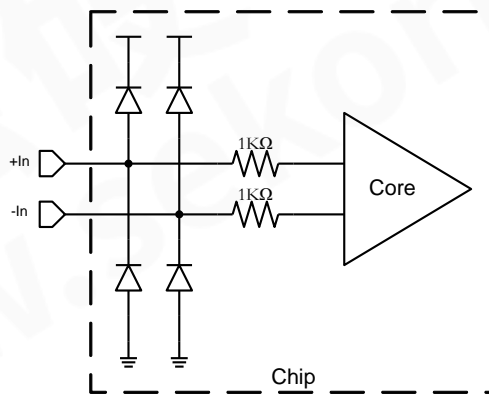

Figure 5 Equivalent Input Structure

Operation Outside of the Common Input Voltage Range

The following is a list of input voltage situation and their outcomes:

1. When both IN- and IN+ are both within the common-mode range:
 - 1) If IN- is higher than IN+ and the offset voltage, the output is low and the output MOSFET is sinking Current.
 - 2) If IN- is lower than IN+ and the offset voltage, the output is high impedance.
2. When IN- is higher than common-mode and IN+ is within common-mode, the output is low and the output MOSFET is sinking current.
3. When IN+ is higher than common-mode and IN- is within common-mode, the output is high impedance.
4. When IN- and IN+ are both higher than common-mode, the output is in uncertain state.

Typical Application

IR Receiver

The device is an ideal candidate to be used as an infrared receiver shown in Figure 6. The infrared photo diode creates a current relative to the amount of infrared light present. The current creates a voltage across R_D . When this voltage level crosses the voltage applied by the voltage divider to the inverting input, the output transitions. Optional R_o provides additional hysteresis for noise immunity.

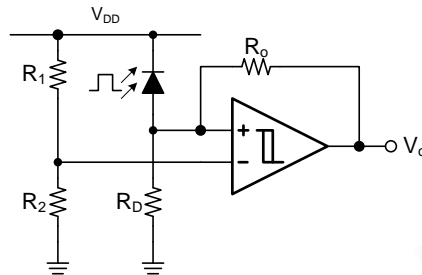
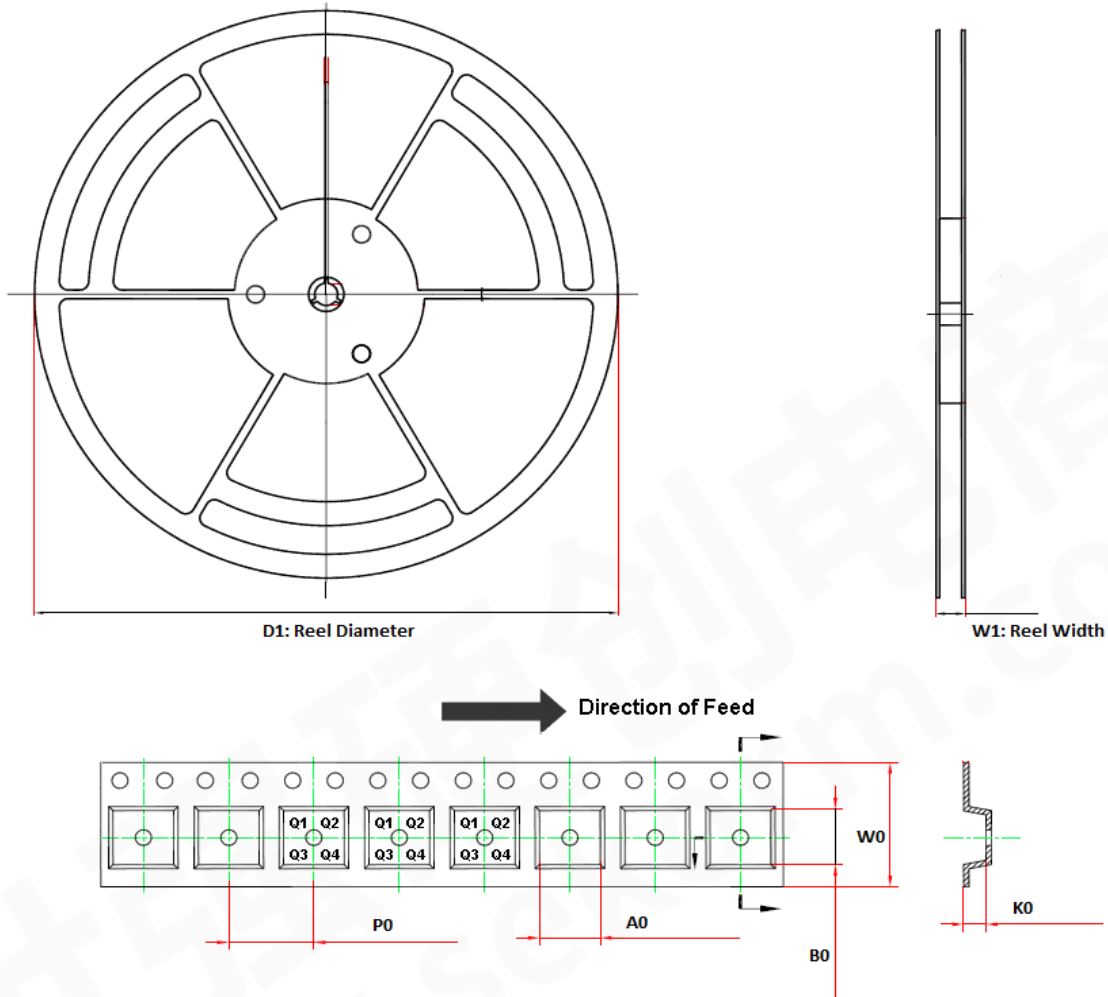

Figure 6. IR Receiver

Tape and Reel Information



Order Number	Package	D1 (mm)	W1 (mm)	A0 (mm)	B0 (mm)	K0 (mm)	P0 (mm)	W0 (mm)	Pin1 Quadrant
LM2903A-SR	SOP8	330.0	17.6	6.4	5.4	2.1	8.0	12.0	Q1
LM2903AL1-SR	SOP8	330.0	17.6	6.4	5.4	2.1	8.0	12.0	Q1
LM2903A-VR	MSOP8	330.0	17.6	5.2	3.3	1.5	8.0	12.0	Q1
LM2901A-SR	SOP14	330.0	21.6	6.5	9.0	2.1	8.0	16.0	Q1
LM2901A-TR	TSSOP14	330.0	17.6	6.8	5.4	1.2	8.0	12.0	Q1

Package Outline Dimensions

SOP8

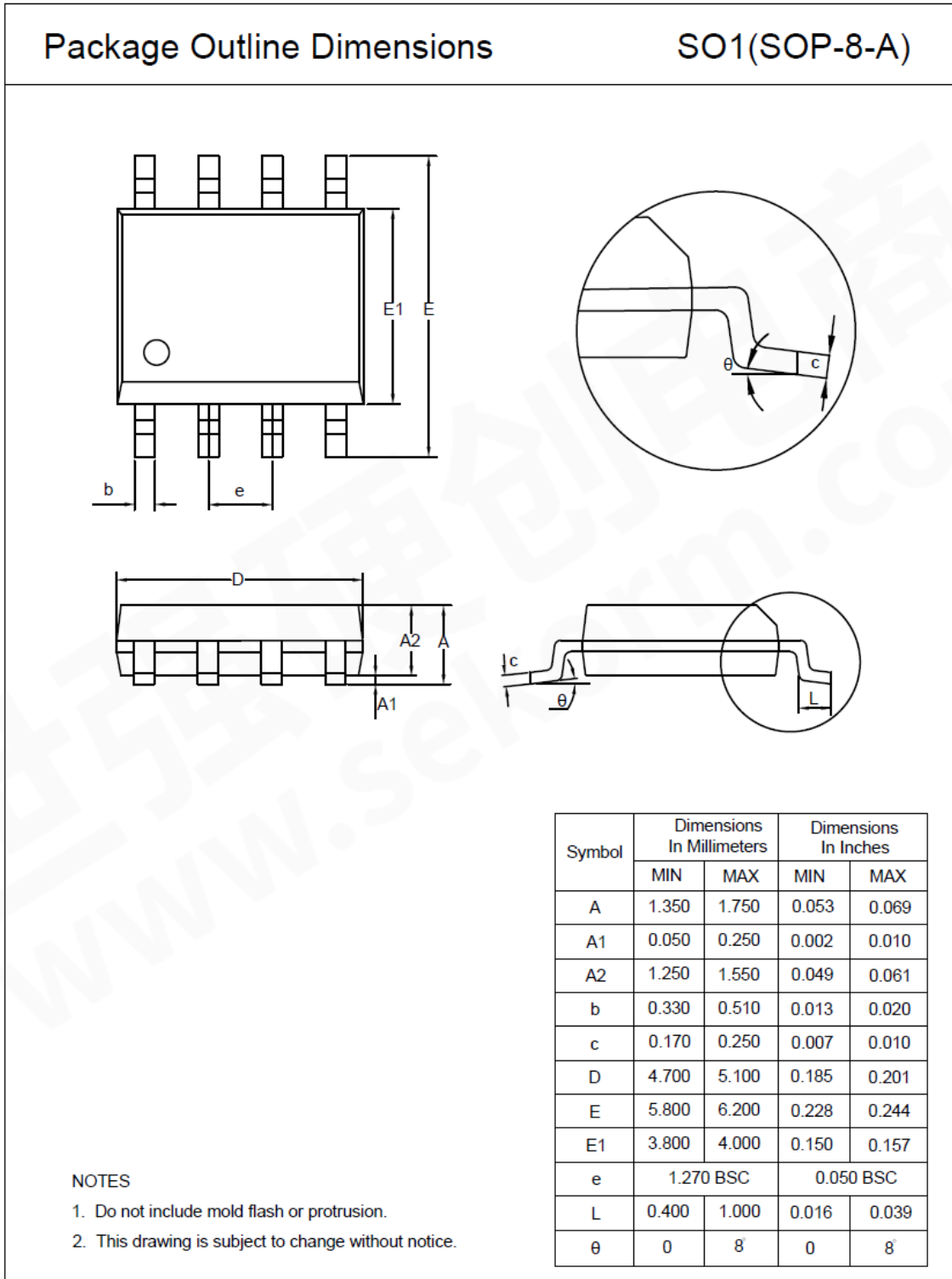

MSOP8

Package Outline Dimensions

VS1(MSOP-8-A)

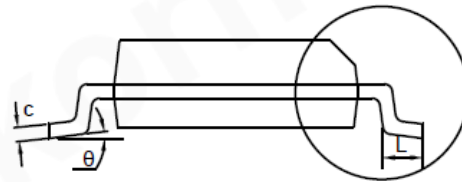
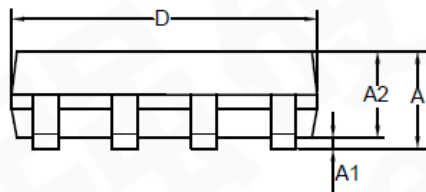
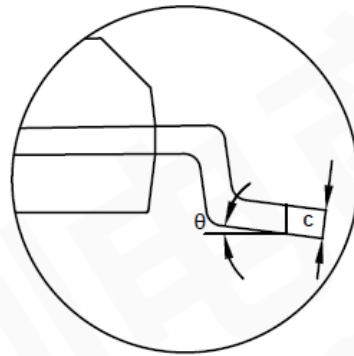
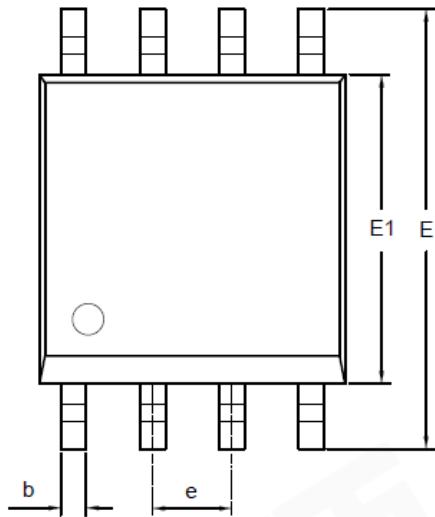

Symbol	Dimensions In Millimeters		Dimensions In Inches	
	MIN	MAX	MIN	MAX
A	0.800	1.100	0.031	0.043
A1	0.050	0.150	0.002	0.006
A2	0.750	0.950	0.030	0.037
b	0.250	0.380	0.010	0.015
c	0.090	0.230	0.004	0.009
D	2.900	3.100	0.114	0.122
E	4.700	5.100	0.185	0.201
E1	2.900	3.100	0.114	0.122
e	0.650 BSC		0.026 BSC	
L	0.400	0.800	0.016	0.031
θ	0	8°	0	8°

NOTES

1. Do not include mold flash or protrusion.
2. This drawing is subject to change without notice.

SOP14

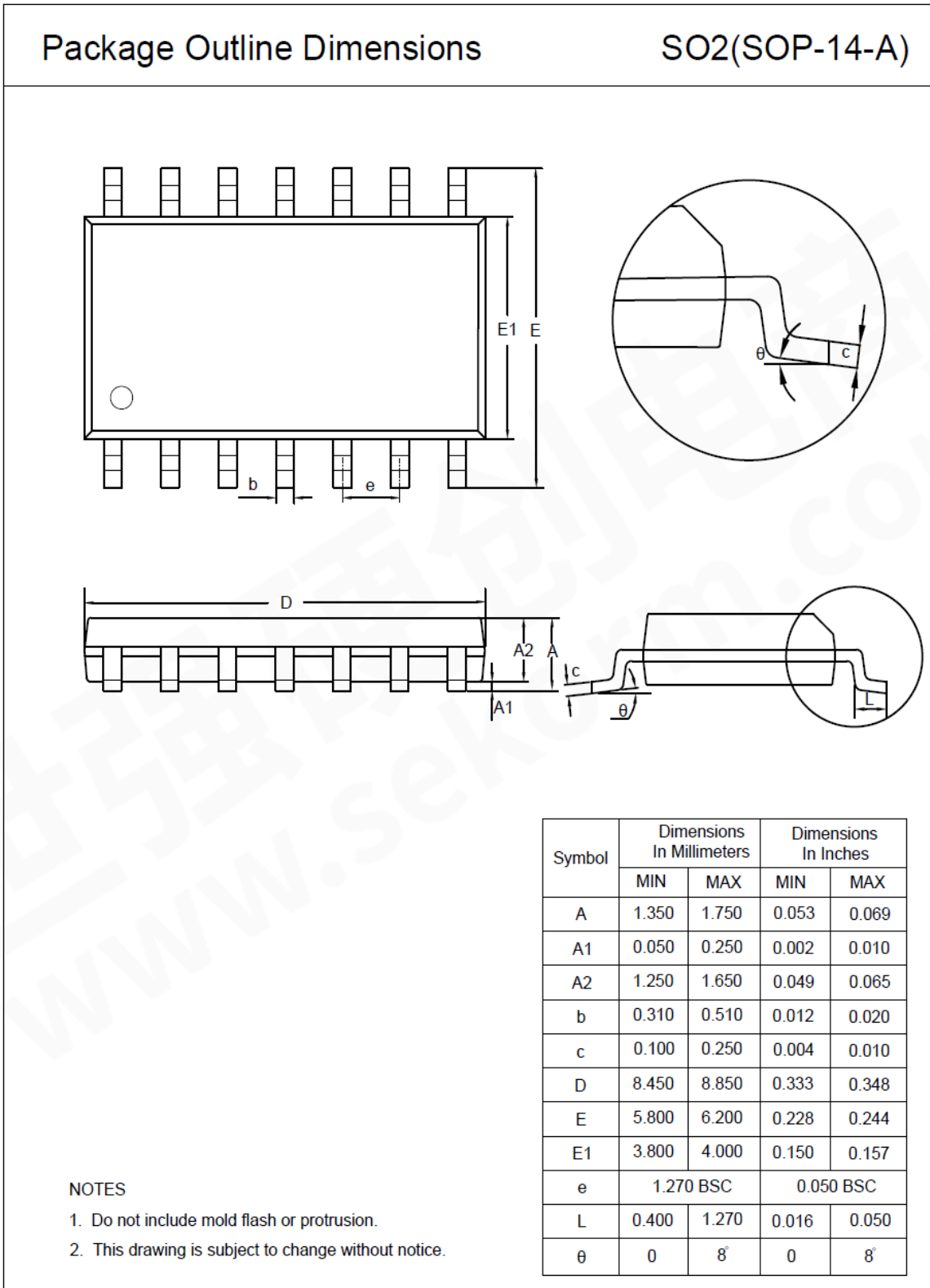

TSSOP14

Package Outline Dimensions

TS2(TSSOP-14-A)

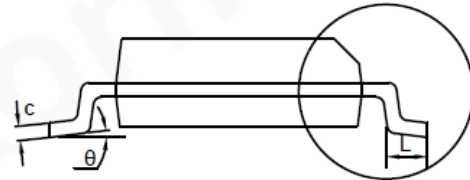
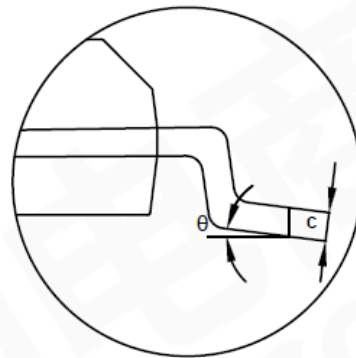
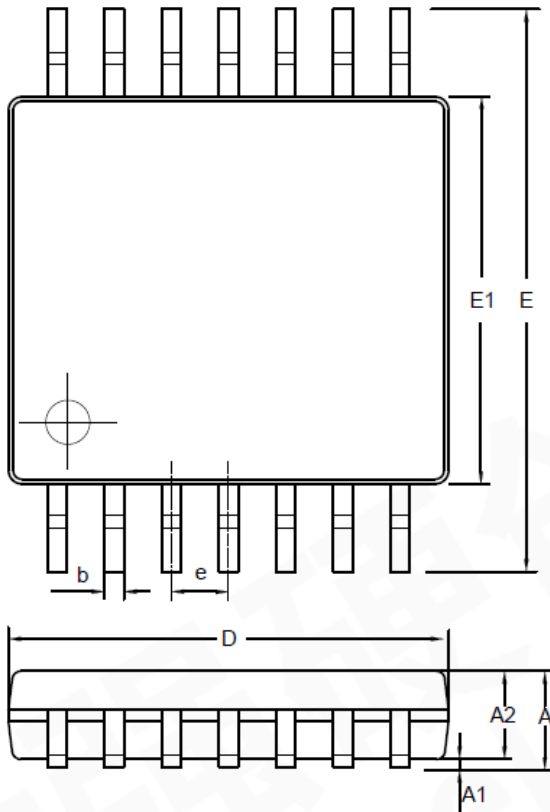

Symbol	Dimensions In Millimeters		Dimensions In Inches	
	MIN	MAX	MIN	MAX
A	0.900	1.200	0.035	0.047
A1	0.050	0.150	0.002	0.006
A2	0.800	1.050	0.031	0.041
b	0.190	0.300	0.007	0.012
c	0.090	0.200	0.004	0.008
D	4.900	5.100	0.193	0.201
E	6.200	6.600	0.244	0.260
E1	4.300	4.500	0.169	0.177
e	0.650 BSC		0.026 BSC	
L	0.450	0.750	0.018	0.030
θ	0	8°	0	8°

NOTES

1. Do not include mold flash or protrusion.
2. This drawing is subject to change without notice.

Order Information

Order Number	Operating Temperature Range	Package	Marking Information	MSL	Transport Media, Quantity	Eco Plan
<u>LM2903AL1-SR</u>	-40 to 125°C	SOP8	2903A	1	Tape and Reel, 4000	Green
<u>LM2903A-SR</u>	-40 to 125°C	SOP8	LM393	3	Tape and Reel, 4000	Green
<u>LM2903A-VR</u>	-40 to 125°C	MSOP8	2903A	3	Tape and Reel, 3000	Green
<u>LM2901A-SR</u>	-40 to 125°C	SOP14	2901A	3	Tape and Reel, 2500	Green
<u>LM2901A-TR</u> ⁽¹⁾	-40 to 125°C	TSSOP14	2901A	3	Tape and Reel, 3000	Green

(1) Future product, contact 3PEAK factory for more information and sample.

Green: 3PEAK defines "Green" to mean RoHS compatible and free of halogen substances.

 **3PEAK and the 3PEAK logo are registered trademarks of 3PEAK INCORPORATED. All other trademarks are the property of their respective owners.**
