

# TPS65400 4.5- to 18-V Input Flexible Power Management Unit With PMBus/I<sup>2</sup>C Interface

## 1 Features

- Efficiency up to 95% for each switching regulator
- Switching regulator specifications:
  - Input voltage range: 4.5 to 18 V
  - $V_{OUT}$  range: 0.6 V-90% $V_{IN}$
  - SW1, SW2  $I_{OUT}$ : 4-A max
  - SW3, SW4  $I_{OUT}$ : 2-A max
- Prebias start-up algorithm minimizes voltage dip during start-up
- Internal undervoltage lockout (UVLO), overcurrent protection (OCP), overvoltage protection (OVP), and overtemperature protection (OTP)
- AECQ-100 grade 1 option
- Thermally enhanced 7-mm × 7-mm 48-pin, 0.5-mm pitch VQFN package
- Pin accessible features:
  - Adjustable  $V_{OUT}$  with external feedback resistors
  - Sequencing control through precision enable pins for each switcher
  - Resistor adjustable PWM switching frequency from 275 kHz to 2.2 MHz
  - Clock sync input and clock output
  - Soft-start delay through external capacitor
  - Current sharing between SW1 and SW2 and between SW3 and SW4 allows support of higher current needs if required
- PMBus runtime control and status
  - Runtime voltage positioning through adjustment of  $V_{REF}$
  - Enable and disable of each switcher
  - Fault and status monitoring
- User-configurable PMBus/I<sup>2</sup>C options, saved in EEPROM
  - Power supply turn-on and turn-off sequencing
  - Sequencing can be based on fixed time delays or PGOOD dependence
  - Initial voltage positioning through VREF configuration
  - PWM frequency adjustment for each switcher
  - Individual PWM phase alignment for each switcher to minimize ripple and capacitor size
  - Adjustable current limit on each regulator enables size and cost optimization of inductors
  - Soft-start time

## 2 Applications

- Small cellular base stations (BTS) (for example: picocells and microcells); macro BTS (using multiple PMUs)
- Power over ethernet (PoE) powered communications infrastructure equipment
- Automotive [infotainment and telematics](#)
- Powering DSP and MCUs
- [Industrial and factory automation](#)
- Systems requiring small form factor, high-efficiency, high-ambient operating temperature, and flexible power management

## 3 Description

The TPS65400 is an integrated PMU optimized for applications requiring small form factor and high power conversion efficiency, enabling small space-constrained equipment with high ambient operating temperature without cooling. The device provides high-power efficiency at a system level by enabling a single stage conversion from an intermediate distribution bus with an optimized combination of regulators.

### Device Information

PART NUMBER	PACKAGE <sup>(1)</sup>	BODY SIZE (NOM)
TPS65400	VQFN (48)	7.00 mm × 7.00 mm

- (1) For all available packages, see the orderable addendum at the end of the data sheet.

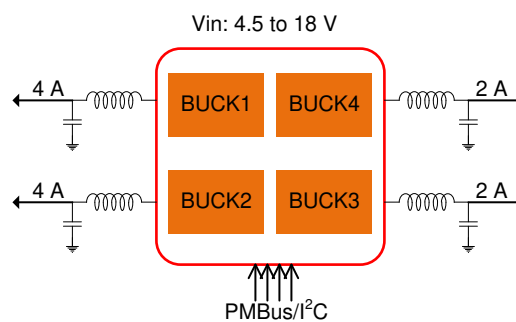

**Simplified Schematic**



## Table of Contents

<b>1 Features</b> .....	1	8.4 Device Functional Modes.....	28
<b>2 Applications</b> .....	1	8.5 Programming.....	29
<b>3 Description</b> .....	1	8.6 Register Maps.....	34
<b>4 Revision History</b> .....	2	<b>9 Application and Implementation</b> .....	54
<b>5 Description (continued)</b> .....	3	9.1 Application Information.....	54
<b>6 Pin Configuration and Functions</b> .....	3	9.2 Typical Applications.....	55
<b>7 Specifications</b> .....	6	<b>10 Power Supply Recommendations</b> .....	67
7.1 Absolute Maximum Ratings.....	6	<b>11 Layout</b> .....	68
7.2 ESD Ratings.....	6	11.1 Layout Guidelines.....	68
7.3 Recommended Operating Conditions.....	6	11.2 Layout Example.....	69
7.4 Thermal Information.....	7	<b>12 Device and Documentation Support</b> .....	70
7.5 Electrical Characteristics.....	7	12.1 Documentation Support.....	70
7.6 System Characteristics.....	9	12.2 Receiving Notification of Documentation Updates..	70
7.7 Operational Parameters.....	10	12.3 Glossary.....	70
7.8 Package Dissipation Ratings.....	10	12.4 Trademarks.....	70
7.9 Typical Characteristics: System Efficiency.....	10	12.5 Electrostatic Discharge Caution.....	70
<b>8 Detailed Description</b> .....	11	12.6 Glossary.....	70
8.1 Overview.....	11	<b>13 Mechanical, Packaging, and Orderable Information</b> .....	70
8.2 Functional Block Diagrams.....	12		
8.3 Feature Description.....	13		

## 4 Revision History

NOTE: Page numbers for previous revisions may differ from page numbers in the current version.

<b>Changes from Revision D (July 2018) to Revision E (March 2022)</b>	<b>Page</b>
• Updated the numbering format for tables, figures, and cross-references throughout the document. ....	1

---

<b>Changes from Revision C (May 2018) to Revision D (July 2018)</b>	<b>Page</b>
• Added soldering and storage temperature .....	6
• Added minimum value for $T_J$ .....	6
• Updated the default timing for $t_{ON\_DELAY}$ and $t_{OFF\_DELAY}$ to 5 ms in the <i>External Sequencing</i> section.....	14

## 5 Description (continued)

The TPS65400 implements a PMBus-I<sup>2</sup>C-compatible digital interface. It helps Core Chip optimize system performance by run-time changing regulated voltage, power sequence, phase interleaving, operating frequency, read back operating status, and so forth.

The TPS65400 consists of four high-current buck switching regulators (SW1, SW2, SW3, and SW4) with integrated FETs. The switching power supplies are intended for powering high-current digital circuits such as the processor, FPGA, ASIC, memory, and digital I/Os. SW1 and SW2 support 4 A each, and SW3 and SW4 support 2 A each. The switching frequency of each regulator is independently adjustable up to 2.2 MHz.

Current limit programmability on each switcher enables optimization of inductor ratings for a particular application configuration not requiring the maximum current capability.

The TPS65400 can be powered from a single-input voltage rail between 4.5 and 18 V, making it suitable for applications running off a 5- or 12-V intermediate power distribution bus.

Sequencing requirements can be met using the individual enable terminals or by programming the sequence through the I<sup>2</sup>C bus into the on-board EEPROM. Output voltages can be set through external resistor networks and VREF can be programmed from 0.6 V to 1.87 V in 10-mV steps. All control and status info can be accessed through a PMBus-compatible I<sup>2</sup>C bus.

The TPS65400 provides a high level of flexibility for monitoring and control through the I<sup>2</sup>C bus while providing the option of programmability through the use of external components and voltage levels for systems not using I<sup>2</sup>C.

## 6 Pin Configuration and Functions

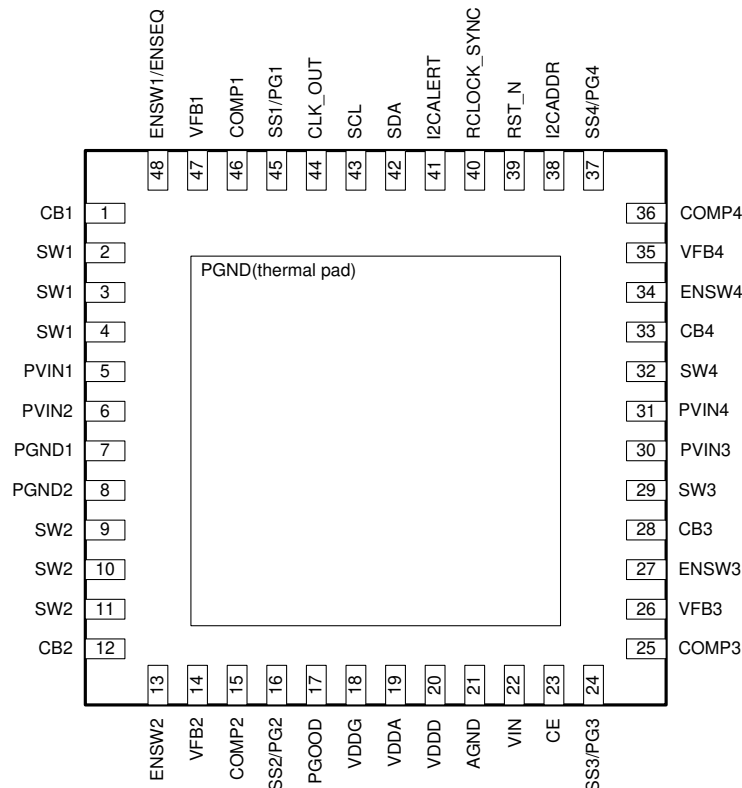

A. Thermal pad must be soldered to PCB as SW3 and SW4 power ground.

**Figure 6-1. 48-Pin VQFN RGZ Package (Top View)**

**Table 6-1. Pin Functions**

PIN		DESCRIPTION
NAME	NO.	
CB1	1	Bootstrap pin for the high-side MOSFET gate drive for SW1
SW1	2	Switch pin for SW1
	3	
	4	
PVIN1	5	Power input for the buck switching regulator SW1
PVIN2	6	Power input for SW2
PGND1	7	Power ground for buck converters
PGND2	8	Power ground for buck converters
SW2	9	Switch pin for SW2
	10	
	11	
CB2	12	Bootstrap pin for the SW2 high-side MOSFET gate drive
ENSW2	13	Enable input pin for SW2. Active high. A 2- $\mu$ A internal pullup current is inside.
VFB2	14	Feedback input pin for SW2
COMP2	15	Compensation pin for external compensation network for SW2. Pulling this line high to VDDA configures the SW1 controller to control both SW1 and SW2.
SS2/PG2	16	Soft start for SW2 (default). A capacitor is used to set the start-up time. This pin can also be reconfigured through I <sup>2</sup> C to display the PGOOD2 signal instead.
PGOOD	17	Default PGOOD signal is for all switchers. It can be changed according to <a href="#">(D2h) PIN_CONFIG_00</a> . If all switchers are disabled, PGOOD is low.
VDDG	18	Supply for gate drives. Bypass locally to PGND.
VDDA	19	Output of internal regulator for analog controls
VDDD	20	3.3-V output of internal regulator digital controls
AGND	21	Ground connection for analog controls
VIN	22	Analog V <sub>IN</sub> . Power input pin for the VDDD, VDDA, and VGATE subregulator power
CE	23	Chip enables. Internal pullup current will default to high if the pin is left floating. Connect to an open-drain output to pull low to disable. Driving with a push-pull output is not recommended. When low, internal regulators are shutdown to minimize power, and functions are disabled. Configuration is reloaded from EEPROM as part of the power-up sequence when CE goes high.
SS3/PG3	24	Soft-start for SW3 (default). A capacitor is used to set the startup time. This pin can also be reconfigured through I <sup>2</sup> C to display the PGOOD3 signal instead.
COMP3	25	Compensation pin for external compensation network for SW3
VFB3	26	Feedback input pin for SW3
ENSW3	27	Enable input pin for SW3. Active high. A 2- $\mu$ A internal pullup current is inside.
CB3	28	Bootstrap pin for SW3 high-side MOSFET gate drive
SW3	29	Switch pin for SW3. The maximum rated output current is 2 A.
PVIN3	30	Power input for buck switching regulator SW3
PVIN4	31	Power input for SW4
SW4	32	Switch pin for SW4. The maximum rated output current is 2 A.
CB4	33	Bootstrap pin for SW4 high-side MOSFET gate drive
ENSW4	34	Enable input pin for SW4. Active high. A 2- $\mu$ A internal pullup current is inside.
VFB4	35	Feedback input pin for SW4
COMP4	36	Compensation pin for external compensation network for SW4. Pulling this line high to VDDA configures the SW3 controller to control both SW3 and SW4.
SS4/PG4	37	Soft start for SW4 (default). A capacitor is used to set the start-up time. This pin can also be reconfigured through I <sup>2</sup> C to display the PGOOD4 signal instead.
I2CADDR	38	Select I <sup>2</sup> C address with a resistor to AGND.

**Table 6-1. Pin Functions (continued)**

PIN		DESCRIPTION
NAME	NO.	
RST_N	39	Reset of digital logic. When low, all switchers are disabled. Configuration is reloaded from EEPROM when RESET_N is deasserted.
RCLOCK_SYNC	40	Resistor for setting primary clock frequency from 275 kHz to 2.2 MHz or for clock sync
I2CALERT	41	Open-drain output that is pulled low for 200 $\mu$ s when a timeout condition is detected by the I <sup>2</sup> C watchdog on either SDA or SCL.
SDA	42	Data input/output pin for I <sup>2</sup> C bus
SCL	43	Clock input pin for I <sup>2</sup> C bus
CLK_OUT	44	Clock output signal. Open-collector output, requires pull up
SS1/PG1	45	Soft start for SW1 (default). A capacitor is used to set the start-up time. This pin can also be reconfigured through I <sup>2</sup> C to display the PGOOD1 signal instead.
COMP1	46	Compensation pin for external compensation network for SW1
VFB1	47	Feedback input pin for SW1
ENSW1/ENSEQ	48	Enable input pin for SW1. Active high. A 2- $\mu$ A internal pullup current is inside.

## 7 Specifications

### 7.1 Absolute Maximum Ratings

over operating free-air temperature (unless otherwise noted) <sup>(1)</sup>

		MIN	MAX	UNIT
Input voltage	PVIN1, PVIN2, PVIN3, PVIN4, VIN	-0.3	20.0	V
	CB1, CB2, CB3, CB4 referenced to SWx	-0.3	7.5	V
	CLK_OUT, VFB1, VFB2, VFB3, VFB4, RST_N, I2CALERT, CLK_OUT, I2CADDR, RCLOCK_SYNC	-0.3	VDDD or 3.6	V
	SW1, SW2, SW3, SW4	-1.0	20.0	V
	VDDA, VDDG	-0.3	7.5	V
	PGOOD, SS1/PG1, SS2/PG2, SS3/PG3, SS4/PG4, COMP1, COMP2, COMP3, COMP4, CE	-0.3	VDDA or 7.5	V
	VDDD	-0.3	3.6	V
	SCL, SDA, ENSW1, ENSW2, ENSW3, ENSW4	-0.3	4.0	V
Junction temperature, T <sub>J-max</sub>			150	°C
Maximum lead temperature (soldering, 10 s)			260	°C
Storage temperature, T <sub>stg</sub>		-55	150	°C

- (1) Stresses beyond those listed under *Absolute Maximum Ratings* may cause permanent damage to the device. These are stress ratings only, which do not imply functional operation of the device at these or any other conditions beyond those indicated under *Recommended Operating Conditions*. Exposure to absolute-maximum-rated conditions for extended periods may affect device reliability.

### 7.2 ESD Ratings

			VALUE	UNIT
V <sub>(ESD)</sub>	Electrostatic discharge	Human body model (HBM), per ANSI/ESDA/JEDEC JS-001, all pins <sup>(1)</sup>	±2000	V
		Charged device model (CDM), per JEDEC specification JESD22-C101, all pins <sup>(2)</sup>	±750	

- (1) JEDEC document JEP155 states that 500-V HBM allows safe manufacturing with a standard ESD control process.  
(2) JEDEC document JEP157 states that 250-V CDM allows safe manufacturing with a standard ESD control process.

### 7.3 Recommended Operating Conditions

over operating free-air temperature range (unless otherwise noted)

		MIN	MAX	UNIT
Input voltage	PVIN1, PVIN2, PVIN3, PVIN4, VIN	-0.3	18.0	V
	CB1, CB2, CB3, CB4 referenced to SWx	-0.3	7.0	V
	ENSW1, ENSW2, ENSW3, ENSW4, SCL, SDA, CLK_OUT, RST_N, SCL, SDA, I2CALERT, CLK_OUT, I2CADDR, RCLOCK_SYNC, VDDD	-0.3	3.3	V
	SW1, SW2, SW3, SW4	-1.0	18.0	V
	VDDA, VDDG	-0.3	7.0	V
	PGOOD, SS1/PG1, SS2/PG2, SS3/PG3, SS4/PG4, COMP1, COMP2, COMP3, COMP4, CE	-0.3	7.0	V
	VFB1, VFB2, VFB3, VFB4	0.6	1.87	V
Load current	I <sub>OUT1</sub> , I <sub>OUT2</sub>	0	4	A
Load current	I <sub>OUT3</sub> , I <sub>OUT4</sub>	0	2	A
Junction temperature		-40	125	°C

## 7.4 Thermal Information

THERMAL METRIC <sup>(1)</sup>		TPS65400	UNIT
		RGZ (VQFN)	
		48 PINS	
R <sub>θJA</sub>	Junction-to-ambient thermal resistance	29.8	°C/W
R <sub>θJC(top)</sub>	Junction-to-case (top) thermal resistance	14.9	°C/W
R <sub>θJB</sub>	Junction-to-board thermal resistance	6.3	°C/W
ψ <sub>JT</sub>	Junction-to-top characterization parameter	0.2	°C/W
ψ <sub>JB</sub>	Junction-to-board characterization parameter	6.3	°C/W
R <sub>θJC(bot)</sub>	Junction-to-case (bottom) thermal resistance	0.8	°C/W

(1) For more information about traditional and new thermal metrics, see the *Semiconductor and IC Package Thermal Metrics* application report, [SPRA953](#).

## 7.5 Electrical Characteristics

V<sub>IN</sub> = 12 V, Frequency = 500 kHz, T<sub>J</sub> = –40°C to 125°C, typical values are at T<sub>J</sub> = 25°C, unless otherwise indicated

PARAMETER	TEST CONDITIONS	MIN	TYP	MAX	UNIT
<b>SWITCHER 1 AND SWITCHER 2</b>					
I <sub>limit1</sub> , I <sub>limit2</sub>	SW1, SW2 high-side current limit adjustment range	2		6	A
I <sub>limit-accuracy</sub>	Accuracy to nominal current limit value	I <sub>limit</sub> = 4 A, 5 A, 6 A		25%	
R <sub>dson HS</sub>	SW1, SW2 HS R <sub>ds(on)</sub>		66		mΩ
R <sub>dson LS</sub>	SW1, SW2 LS R <sub>ds(on)</sub>		42		mΩ
<b>SWITCHER 3 AND SWITCHER 4</b>					
I <sub>limit3</sub> , I <sub>limit4</sub>	SW3 and SW4 current limit	0.5		3	A
I <sub>limit accuracy</sub>	Accuracy to nominal current limit value	I <sub>limit</sub> = 1 A, 2 A, 3 A		25%	
R <sub>dson HS</sub>	SW3 and SW4 HS R <sub>ds(on)</sub>		120		mΩ
R <sub>dson LS</sub>	SW3/4 LS R <sub>ds(on)</sub>		90		mΩ
<b>FEEDBACK AND ERROR AMPLIFIERS FOR SW1 – SW4</b>					
VFB	Accuracy	V <sub>REF</sub> = 1 V		1%	
V <sub>REFn</sub>	Error amplifier reference voltage	Default value		800	mV
V <sub>REF_STEP</sub>	I <sup>2</sup> C programmable V <sub>REF</sub> step size		10		mV
G <sub>m</sub>	Error amplifier transconductance	95	133	165	μS
I <sub>sink</sub>	Sink		12		μA
I <sub>source</sub>	Source		12		μA
<b>PWM SWITCHING CHARACTERISTICS</b>					
Phase_err12 <sup>(1)</sup>	Phase error between SW1 and SW2	F <sub>sw</sub> = 1.1 MHz		5°	
Phase_err34 <sup>(1)</sup>	Phase error between SW3 and SW4	F <sub>sw</sub> = 1.1 MHz		5°	
F <sub>sw</sub>	Resistor-configurable PWM switching configuration		275	2200	kHz
F <sub>sw-accuracy</sub>	PWM switching frequency accuracy	R <sub>osc</sub> = 165 kΩ (F <sub>sw</sub> = 1.1 MHz)		10%	
V <sub>rclock_sync</sub>	Voltage reference for RCLOCK_SYNC		0.8		V
t <sub>ON_min</sub>	Lower duty cycle limit		80	150	ns
t <sub>OFF_min</sub>	Minimum off-time limit (constrains the maximum achievable duty cycle)		150		ns
<b>CLOCK SYNC</b>					
V <sub>H_SYNC</sub>	High signal threshold		2.6		V
V <sub>L_SYNC</sub>	Low signal threshold			1	V

$V_{IN} = 12\text{ V}$ , Frequency = 500 kHz,  $T_J = -40^\circ\text{C}$  to  $125^\circ\text{C}$ , typical values are at  $T_J = 25^\circ\text{C}$ , unless otherwise indicated

PARAMETER	TEST CONDITIONS	MIN	TYP	MAX	UNIT	
$I_{CLKOUT}$	Max current sink/source for CLK_OUT		2		mA	
$t_{min\_SYNC}$	Minimum detectable time for sync pulse			150	ns	
$F_{SYNC}$	Frequency synchronization range	275		2200	kHz	
$T_{SYNC\_DELAY}$	Delay between input pulse to RCLOCK_SYNC and rising edge of CLK_OUT and PWM output		20		ns	
<b>TIMING CHARACTERISTICS</b>						
$t_{restart}$	Delay for restart during repeated OCP condition		20		ms	
<b>INTERNAL REGULATORS AND UVLO</b>						
$V_{DDA}$	Internal subregulator output	$V_{in} > 6.6\text{ V}$	6.1		V	
		$4.5\text{ V} < V_{in} < 6.6\text{ V}$	$V_{in} - 0.1$			
$V_{DDD}$	Output of internal subregulator		3.2		V	
$V_{DDG}$	Output of internal regulator for gate drivers	$V_{in} > 6.6\text{ V}$	6.1		V	
		$4.5\text{ V} < V_{in} < 6.6\text{ V}$	$V_{in} - 0.1$			
$I_{VIN}$	Quiescent non-switching, no load current	CE high, $V_{FB} \gg V_{REF}$ , (no switching)	8		mA	
$I_{SD}$	Quiescent shutdown current	CE low	12	27	$\mu\text{A}$	
$V_{IN\_UVLO}$	Input voltage UVLO	Rising	4.25	4.48	V	
$V_{IN\_UVLO}$	Input voltage UVLO	Falling	3.4	3.75	V	
<b>PGOOD, ENSWx, RST_N, SSx, PG</b>						
$R_{L\_PGOOD}$	Resistance of PGOOD outputs when low		500		$\Omega$	
$V_{OL\_PGOOD}$	Logic output low voltage	$I_{OL} = 100\ \mu\text{A}$		0.1	V	
$I_{SS}$	Soft-start current		4.1	5.6	7.3	$\mu\text{A}$
$V_{EN}$	Enable logic high threshold (for ENSW1, ENSW2, ENSW3, ENSW4)	$V_{EN}$ rising	1.12	1.20	1.28	V
$V_{EN\_L}$	Enable logic low threshold (for ENSW1, EN_L ENSW2, ENSW3, ENSW4)	$V_{EN}$ falling	0.97	1.07		V
$V_{EN\_HYS}$	Enable hysteresis (for ENSW1, ENSW2, ENSW3, ENSW4)	$V_{EN}$ falling		130		mV
$I_{EN}$	ENSWx pin pullup current	$V_{EN} = 0$		2		$\mu\text{A}$
$I_{CE}$	CE pin pullup current	$V_{CE} = 0$		2		$\mu\text{A}$
$V_{IH\_CE}$	Logic input high for CE		1.3			V
$V_{IL\_CE}$	Logic input low CE			0.4		V
$V_{IH\_RSTN}$	Logic input high RST_N		1.3			V
$V_{IL\_RSTN}$	Logic input low RST_N			0.4		V
<b>I<sup>2</sup>C MODULE (SDA, SCL, I2CALERT, I2CADDR)</b>						
$V_{IL\_I2C}$	Logic input low SCL, SDA			0.8		V
$V_{IH\_I2C}$	Logic input high for SCL, SDA		2.1			V
$R_{L\_I2C}$	ON resistance of I <sup>2</sup> C pins (SDA, SCL, I2CALERT) to GND	I2CALERT = 1		85		$\Omega$
$V_{OL\_I2C}$	Logic output low voltage for SCL, SDA, I2CALERT pins	$I_{OL} = 350\ \mu\text{A}$		0.1		V
$I_{LEAK}$	Input leakage current	SDA, SCL = 3.3 V		1		$\mu\text{A}$
$I_{I2CADDR}$	Source current of I2CADDR pin	VDDD = 3.3 V, $V_{IN} > 4.5\text{ V}$		20		$\mu\text{A}$
$t_{TIMEOUT}$	Timeout detection on SDA or SCL low			30		ms
$t_{TIMEOUT\_PULSE}$	Duration of timeout pulse on I2CALERT			200		$\mu\text{s}$

$V_{IN} = 12\text{ V}$ , Frequency = 500 kHz,  $T_J = -40^\circ\text{C}$  to  $125^\circ\text{C}$ , typical values are at  $T_J = 25^\circ\text{C}$ , unless otherwise indicated

PARAMETER		TEST CONDITIONS	MIN	TYP	MAX	UNIT
<b>FAULTS</b>						
$T_{TSD}^{(2)}$	Thermal shutdown threshold			160		$^\circ\text{C}$
$T_{TSD\_restart}^{(2)}$	Thermal shutdown hysteresis			20		$^\circ\text{C}$
$V_{FB\_OVP}$	OVP threshold rising (fault latched, PGOOD asserted)	$0.6\text{ V} < V_{REF} < 1.87\text{ V}$		111		% of $V_{REF}$
	OVP threshold falling (fault cleared, PGOOD deasserted)	$0.6\text{ V} < V_{REF} < 1.87\text{ V}$		104		% of $V_{REF}$
$t_{OVPSDOWN}$	Time after OVP before protection activation and PGOOD fall			55	95	$\mu\text{s}$
$V_{FB\_UVP}$	Undervoltage threshold (PGOOD deasserted)	$0.6\text{ V} < V_{REF} < 1.87\text{ V}$		92		% of $V_{REF}$
	Undervoltage threshold (PGOOD asserted)	$0.6\text{ V} < V_{REF} < 1.87\text{ V}$		83		% of $V_{REF}$
$t_{UVPSDOWN}$	Time after UVP before PGOOD fall			55	95	$\mu\text{s}$

(1) Specified by design

(2) Specified by lab validation

## 7.6 System Characteristics

The following specification table entries are specified by the design (component values provided in the typical application circuit are used). These parameters are not specified by production testing. minimum and max values apply over the full operating ambient temperature range ( $-40^\circ\text{C} \leq T_J \leq 125^\circ\text{C}$ ), over the  $V_{IN}$  range = 5 to 12 V, and  $I_{OUT}$  range unless otherwise specified.  $L = 3.3\ \mu\text{H}$ ,  $\text{DCR} = 10.4\ \text{m}\Omega$ ,  $V_{OUT} = 1.2\ \text{V}$ , 1% FB resistor.

PARAMETER		TEST CONDITIONS	MIN	TYP	MAX	UNIT
$V_{LINEREG}$	Line regulation			0.1		%/V
$V_{LOADREG}$	Load regulation			0.1		%/A
$t_r$	VOUT step duration ( $t_r$ )	For 50-mV step		30		$\mu\text{s}$
$t_s$	VOUT step settling time ( $t_s$ )	For 50-mV step		30		$\mu\text{s}$
$V_{OVUV}$	VOUT step overshoot/undershoot	For 50-mV step		6		mV
Efficiency (SW1 and SW2)		$V_{IN} = 5\text{ V}$ , $V_O = 1.2\text{ V}$ , $I_{OUT} = 4\text{ A}$ , $f_{sw} = 500\text{ kHz}$		77%		
		$V_{IN} = 12\text{ V}$ , $V_O = 1.2\text{ V}$ , $I_{OUT} = 4\text{ A}$ , $f_{sw} = 500\text{ kHz}$		76%		
Efficiency (SW3 and SW4)		$V_{IN} = 5\text{ V}$ , $V_O = 1.2\text{ V}$ , $I_{OUT} = 2\text{ A}$ , $f_{sw} = 500\text{ kHz}$		77%		
		$V_{IN} = 12\text{ V}$ , $V_O = 1.2\text{ V}$ , $I_{OUT} = 2\text{ A}$ , $f_{sw} = 500\text{ kHz}$		74%		
$I_{OUT\_match}$	Average <sup>(1)</sup> current sharing accuracy (SW1 and SW2, SW3 and SW4)	$I_{load} = I_{OUTmax}$		20%		
$IPK_{match}$	Peak current <sup>(2)</sup> sharing accuracy (SW1 and SW2, SW3 and SW4)	$I_{load} = I_{OUTmax}$			20%	
$t_{acc}$	Timing accuracy for delays and restarts		-10%		10%	
$t_{reset\_delay}$	Time after RSTn or CE is released for power sequence to begin	Default value		1		ms
$t_{reset\_delay\_max0}$	Minimum delay after reset is released for power sequence to begin	$t_{reset\_delay}$ set to 0 ms			1.1	ms

(1) Average current sharing accuracy is highly dependent on the matching of the inductor and capacitor.

(2) Peak current sharing accuracy refers to the max inductor current in each phase.

## 7.7 Operational Parameters

Values recommended that ensure proper system behavior

PARAMETER		MIN	TYP	MAX	UNIT
$C_A$	Stabilization capacitor to be connected to VDDA		4.7		$\mu\text{F}$
$C_D$	Stabilization capacitor to be connected to VDDD		3.3		$\mu\text{F}$
$C_G$	Stabilization capacitor to be connected to VDDG		10		$\mu\text{F}$
Vin1, Vin2, Vin3, Vin4	SW1 to SW4 input voltage	4.5		18	V
Vout1, Vout2, Vout3, Vout4	SW1 to SW4 output voltage	0.6		90% of $V_{IN}$	V

## 7.8 Package Dissipation Ratings

PACKAGE	$R_{\theta JA}$ ( $^{\circ}\text{C}/\text{W}$ ) <sup>(1)</sup>	$T_A = 25^{\circ}\text{C}$	$T_A = 55^{\circ}\text{C}$	$T_A = 85^{\circ}\text{C}$
RGZ	29.8	4.5 W	3.14 W	1.77 W

(1) For more information about traditional and new thermal metrics, see the *Semiconductor and IC Package Thermal Metrics* application report, [SPRA953](#).

## 7.9 Typical Characteristics: System Efficiency

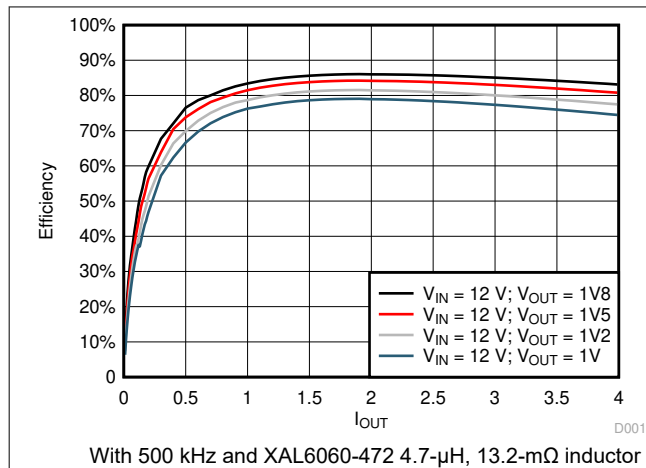

**Figure 7-1. Buck1 and Buck2 Power Efficiency,  $V_{IN} = 12\text{ V}$**

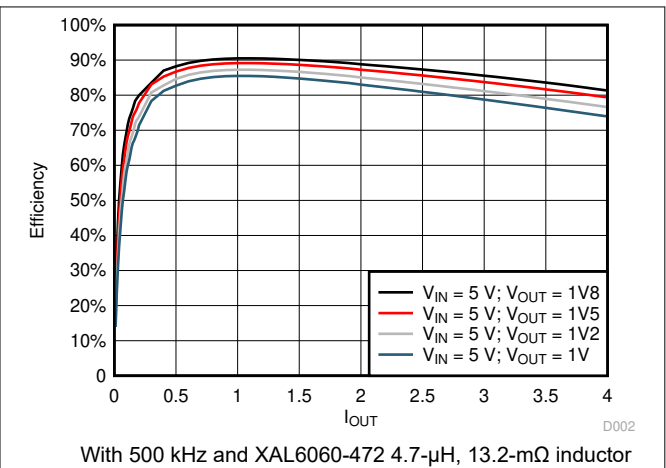

**Figure 7-2. Buck1 and Buck2 Power Efficiency,  $V_{IN} = 5\text{ V}$**

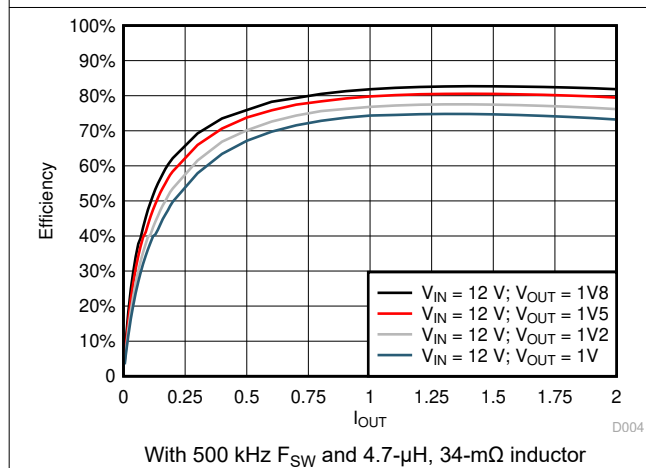

**Figure 7-3. Buck3 and Buck4 Power Efficiency,  $V_{IN} = 12\text{ V}$**

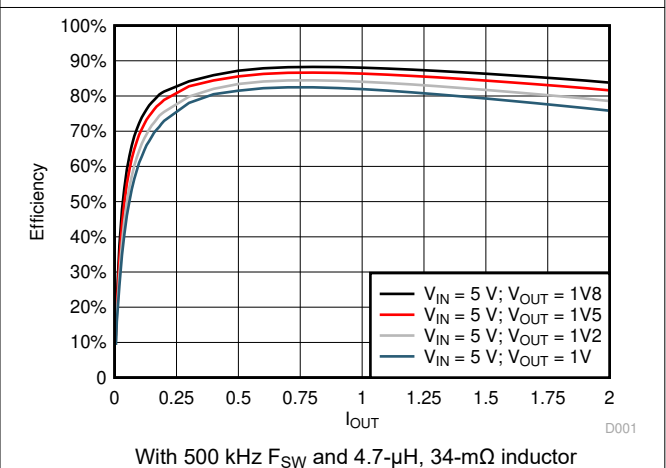

**Figure 7-4. Buck3 and Buck4 Power Efficiency,  $V_{IN} = 5\text{ V}$**

## 8 Detailed Description

### 8.1 Overview

The TPS65400 is an integrated PMU optimized for applications that require small form factor and high-power conversion efficiency enabling small space-constrained equipment with high-ambient operating temperature without cooling. It provides high-power efficiency at a system level by enabling a single-stage conversion from an intermediate distribution bus with an optimized combination of regulators.

The TPS65400 consists of four high-current buck-switching regulators (SW1, SW2, SW3, and SW4) with integrated FETs. The switching power supplies are intended for powering high-current digital circuits such as the processor, FPGA, ASIC, memory, and digital I/Os. SW1 and SW2 support 4 A each, and SW3 and SW4 support 2 A each. Each regulator's switching frequency is independently adjustable up to 2.2 MHz.

Current limit programmability on each switcher enables optimization of inductor ratings for a particular application configuration not requiring the maximum current capability.

The TPS65400 can be powered from a single-input voltage rail between 4.5 and 18 V, making it suitable for applications running off a 5- or 12-V intermediate power distribution bus.

Sequencing requirements can be met using the individual enable pins or by programming the sequence through the I<sup>2</sup>C bus into the onboard EEPROM. Output voltages can be set through external resistor networks and VREF can be programmed from 0.6 to 1.87 V in 10-mV steps. All control and status info can be accessed through a PMBus-compatible I<sup>2</sup>C bus.

The TPS65400 provides a high level of flexibility for monitoring and control through the I<sup>2</sup>C bus while providing the option of programmability through the use of external components and voltage levels for systems not using I<sup>2</sup>C.

## 8.2 Functional Block Diagrams

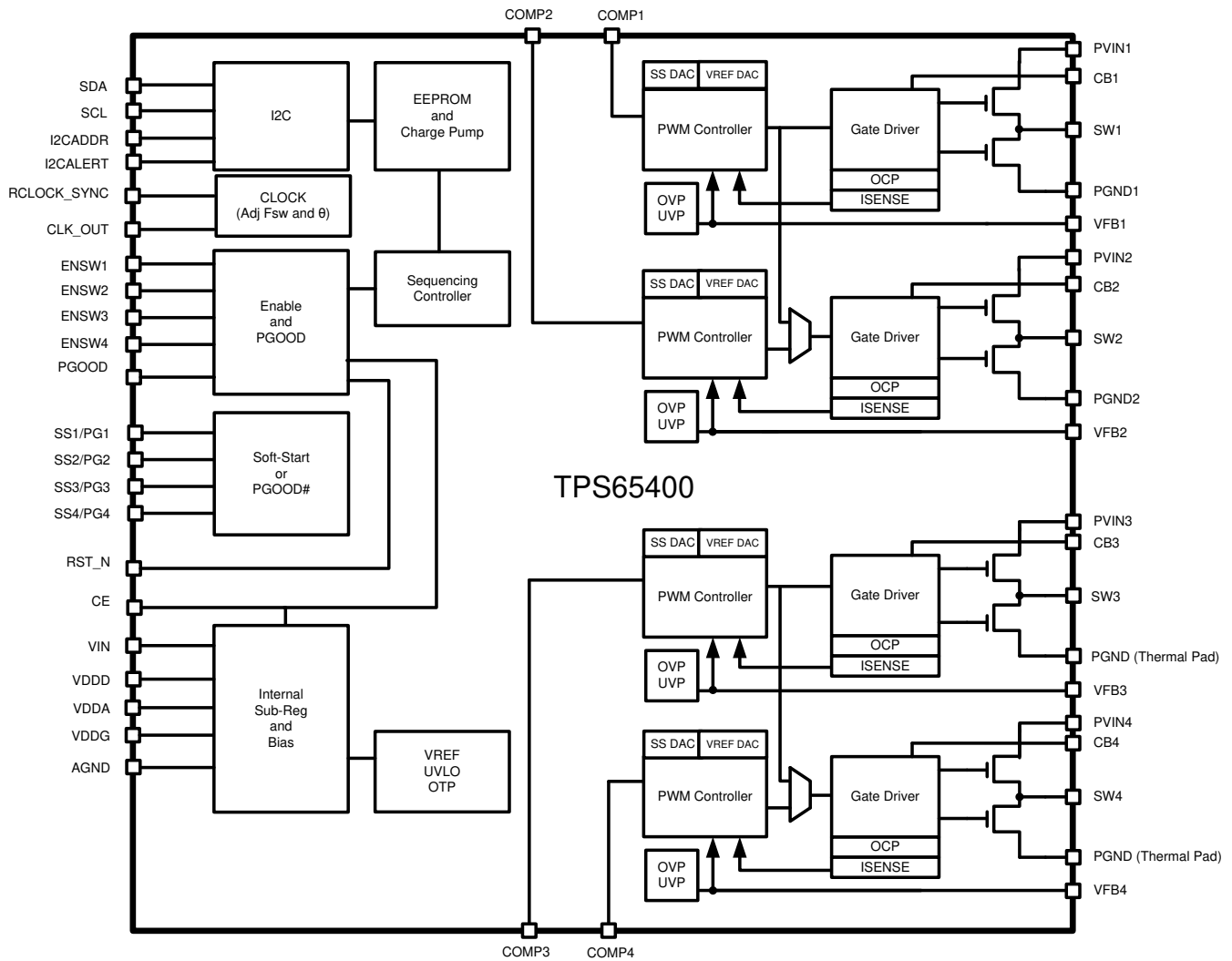
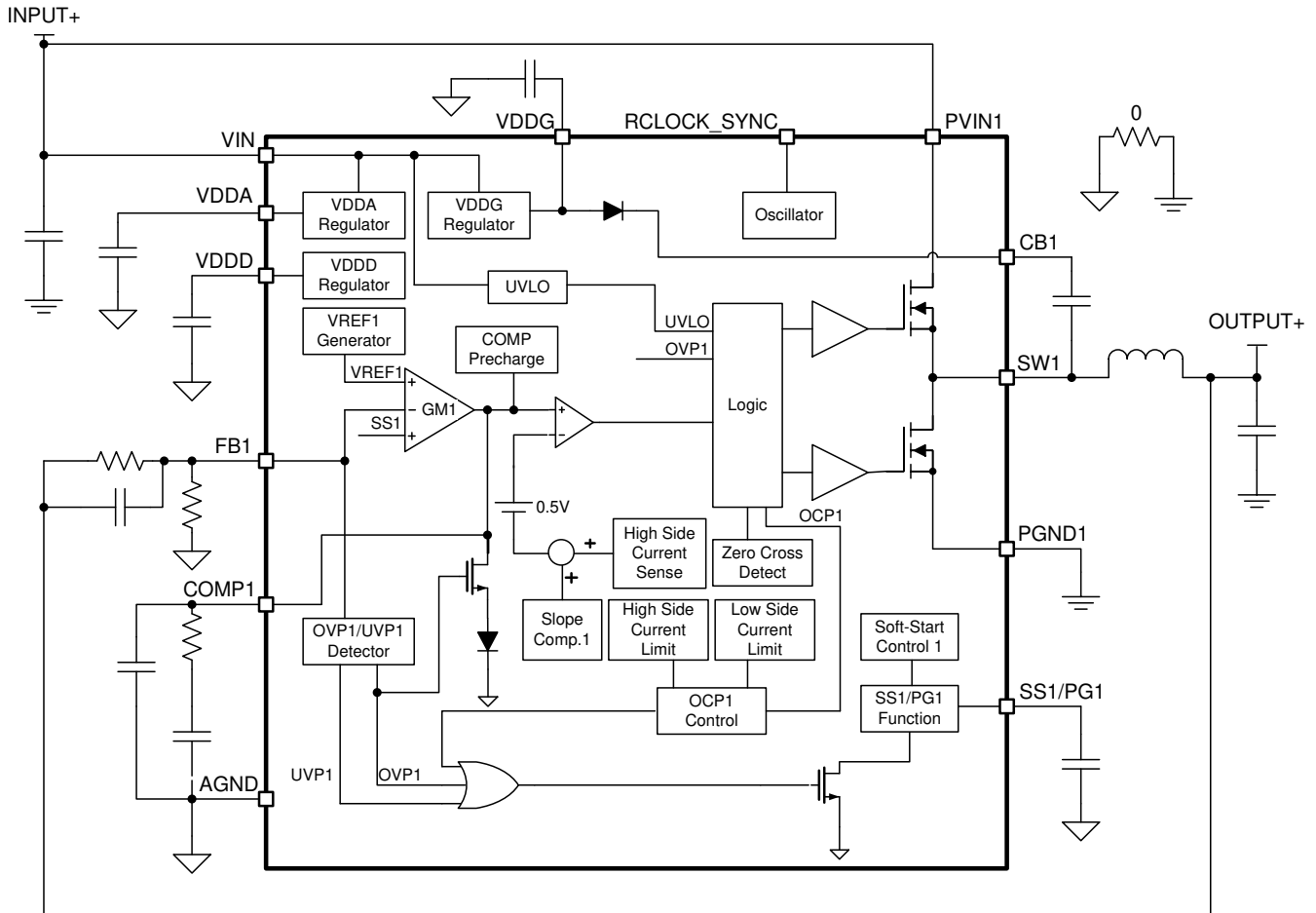

Figure 8-1. TPS65400 Functional Block Diagram



A. All other switchers follow the same pattern

Figure 8-2. Simplified Control Block Diagram for Switcher1

## 8.3 Feature Description

### 8.3.1 Startup Timing and Power Sequencing

#### 8.3.1.1 Startup Timing

Figure 8-3 shows the startup timing of the TPS65400. Upon power-up or the rising edge of CE, the internal power rails VDDA, VDDG, and VDDD startup during the time labeled  $t_{start}$ . Following  $t_{start}$ , a delay of  $t_1$  follows (which is defined by the user through the timing of RST\_N). During time  $t_{start}$  and  $t_1$ , the COMP terminal is internally discharged through a 2-kΩ resistor. At the rising edge of RST\_N, the TPS65400 begins two actions:

1. The TPS65400 begins its precharge of the COMP terminal (indicated by  $t_{precharge}$ ). The length of  $t_{precharge}$  needed to precharge the COMP terminal depends on the time constant of the R and C components. The internal precharge voltage source remains on even during normal operation, preventing the COMP terminal from falling below 0.6 V except during faults (OVP, OCP, and so forth).
2. The TPS65400 begins its configuration sequence (indicated by  $t_{config}$ ), and loads parameters from the EEPROM. Parameters to be set include  $V_{out}$ , switching frequency, soft-start timing, and current limit.

After  $t_{config}$  is complete,  $t_{reset\_delay}$  begins. The length of  $t_{reset\_delay}$  is user-configurable through PMBus register DCh. After  $t_{reset\_delay}$  is complete, the TPS65400 begins its startup sequence. The startup sequence is EEPROM-configurable, so any of the four switchers could be the first to startup with a configurable delay. In this particular example, SW1 is configured to startup first after a delay of  $t_{SW1\_TON\_DELAY}$ , which is configurable through PMBus register (DDh) TON\_TOFF\_DELAY.

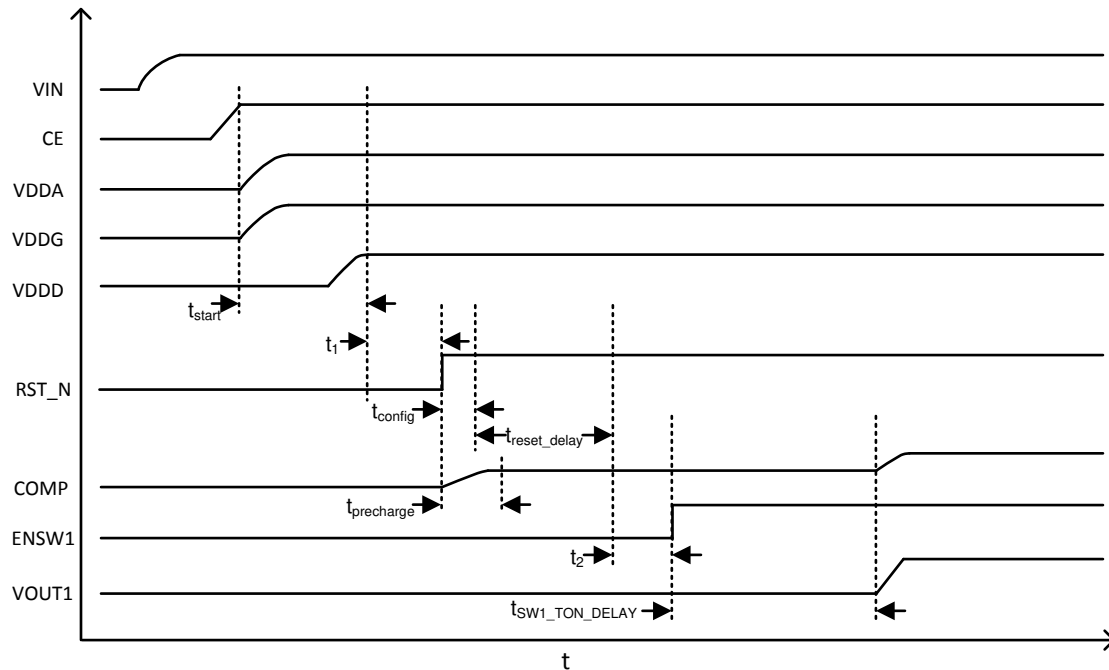

A. PGOOD1 and ENSW2 are tied together externally, and  $t_{ON\_DELAY1}$  and  $t_{ON\_DELAY2}$  are configured through PMBus.

**Figure 8-3. Timing Showing Startup from CE**

To summarize, the length of time from rising edge of CE to soft-start of the first switcher in the sequence is:

$$t_{CE\_to\_SS} = t_{start} + t_1 + t_{config} + t_{reset\_delay} + t_2 + t_{SW1\_ON\_DELAY} \quad (1)$$

The delays,  $t_{reset\_delay}$  and  $t_{SW1\_ON\_DELAY}$ , are both configurable through PMBus. The delay,  $t_{config}$ , is typically 1.1 ms. The delays,  $t_1$  and  $t_2$ , are determined by the user-defined timing of RST\_N and ENSW1. They can both be set to 0 by pulling RST\_N high before the end of  $t_{start}$  and ENSW1 high before the end of  $t_{reset\_delay}$ . One simple way to do this would be to tie both signals to VDDD.

### 8.3.1.2 External Sequencing

To use external sequencing, either connect all the enable pins (ENSW1, ENSW2, ENSW3, and ENSW4) to an external sequencing controller, or connect them to PGOOD outputs as shown in [Figure 8-4](#). By default,  $t_{ON\_DELAY}$  and  $t_{OFF\_DELAY}$  are both set to 5 ms. This allows the user complete flexibility of sequencing order and timing with the ENSWx pins without modifying any of the default settings in the TPS65400.

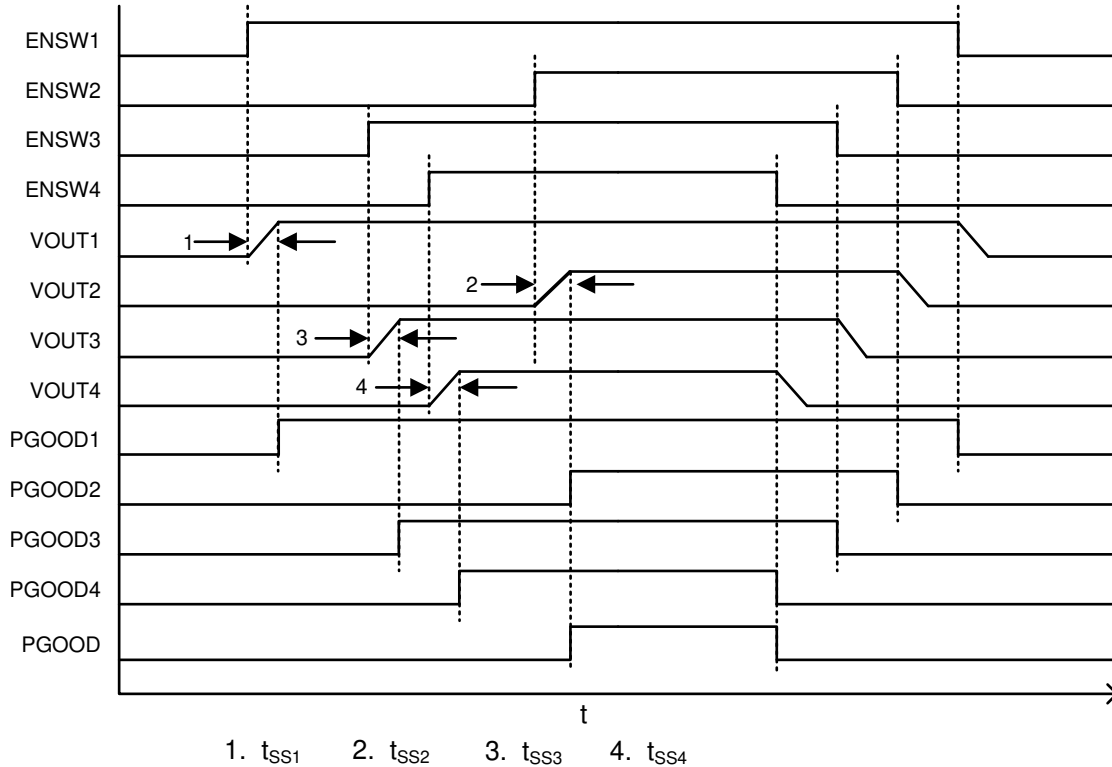

A. Default behavior (external sequencing)

**Figure 8-4. Example of Sequencing Where Timing is Controlled by an External Sequencer With ENSWx Pins**

### 8.3.1.3 Internal Sequencing

The default settings for SEQUENCE\_ORDER (see [\(D5h SEQUENCE\\_ORDER\)](#)) effectively disable sequencing by setting all switchers to start at the same time. Therefore, to use internal sequencing, the default values for SEQUENCE\_ORDER must be changed to the desired sequence. In addition, the user can configure the start or stop sequence to have a dependence on the PGOOD output of the previous switcher, or to wait for a set delay. If configured to have a dependence on PGOOD, the soft-start for the next switcher begins after PGOOD of the previous goes high and the wait time determined by  $t_{ON\_DELAY}$  is complete. If configured to wait for a set delay, the wait time determined by  $t_{ON\_DELAY}$  begins immediately upon the enabling of the previous switcher.

In addition, each supply can be disabled such that it is bypassed in the power-up sequence. For example, if the sequence is SW1-SW2-SW3-SW4, and SW2 is disabled, then SW3 will be powered up after SW1. The initial configuration of the TPS65400 (for first-time power-up) needs to be done using one of the methods described in [Section 8.3.14](#).

### 8.3.2 UVLO and Precision Enables

The TPS65400 implements a UVLO function that prevents startup when the voltage at VIN (terminal 22) is below 4 V. In most applications, VIN and all of the power rails (PVIN1, PVIN2, PVIN3, and PVIN4) are tied to the same source and this single UVLO function is sufficient. However, in some applications, the power rails may be tied to different input voltages, and there is the possibility that the TPS65400 may attempt to startup a switcher even when its associated PVINx rail has not reached a high-enough voltage. In these cases, the precision enable threshold on each ENSWx can be used to precisely set the startup threshold for each individual switcher with a simple resistor divider to PVINx.

In cases where a single UVLO threshold is needed for all four switchers, but at a different level than 4 V, the TPS65400 can be configured for single-terminal enable (PMBus register D2h, bits 0:1 = 10) where the ENSW1/ENSEQ terminal is used as a sequence enable terminal. Then, a resistor divider to the appropriate PVINx rail can be used to set a precise UVLO threshold that applies to all four switchers.

### 8.3.3 Soft-Start and Prebiased Startup

The TPS65400 implements a soft-start function that minimizes discharge of the output when starting up in a prebiased condition. Soft-start time,  $t_{SS}$ , is set by  $t_{ON\_TRANSITION\_RATE}$  (digital soft-start) or by a capacitor connected to the corresponding SSx pin (analog soft-start). In this setup, the SSx pin sources a 5- $\mu$ A current charging the capacitor, and the voltage at the SSx pin limits the reference voltage at the input of the error amplifier.

At the beginning of the soft-start, the soft-start input to the error amplifier is set to 0. The SSx input is raised gradually and reaches its target value during the time  $t_{SS}$ . If  $V_{FB} > V_{SS}$ , then no switching occurs. After the Soft-Start signal crosses  $V_{FB}$ , the switching begins. The first switching pulse is on the low-side FET, which charges the high-side bootstrap capacitor. The unit runs in discontinuous conduction mode (DCM) with the zero-cross detector enabled on the low side (diode emulation). The high-side FET is pulsed according to the error amplifier output on the COMP pin. If the IC is configured for continuous conduction mode (CCM) operation (default), the low-side FET pulses gradually transition to normal CCM operation; at each successive switching cycle, the low-side gate pulse is gradually ramped until full synchronous switching occurs. At this point, the switcher enters normal CCM operation.

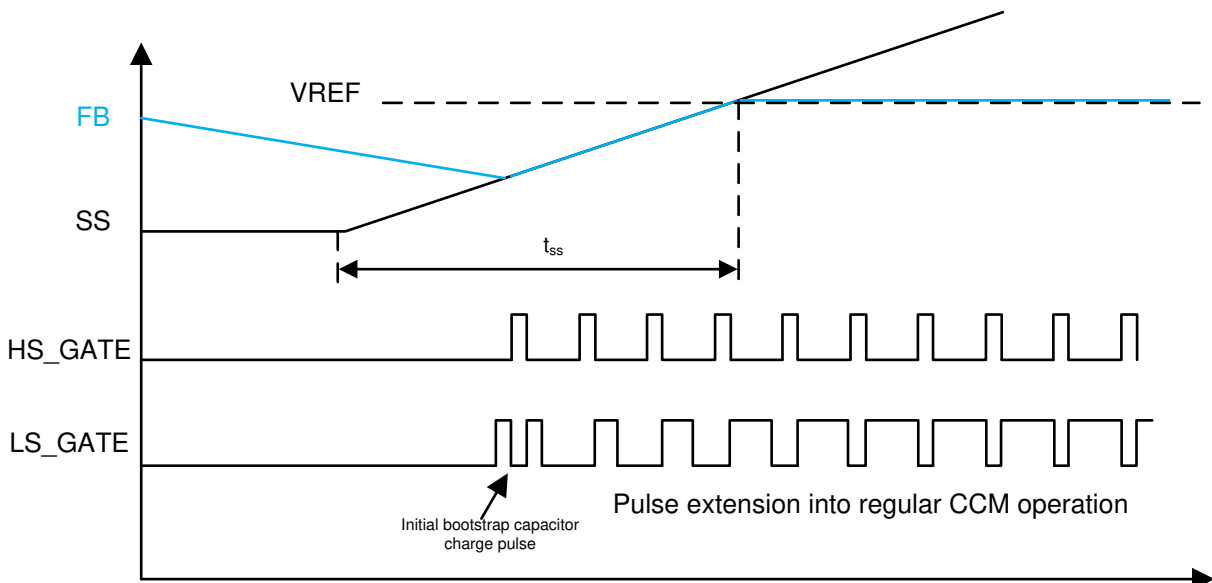

**Figure 8-5. Soft-Start Under Prebiased Condition and CCM Mode Programmed**

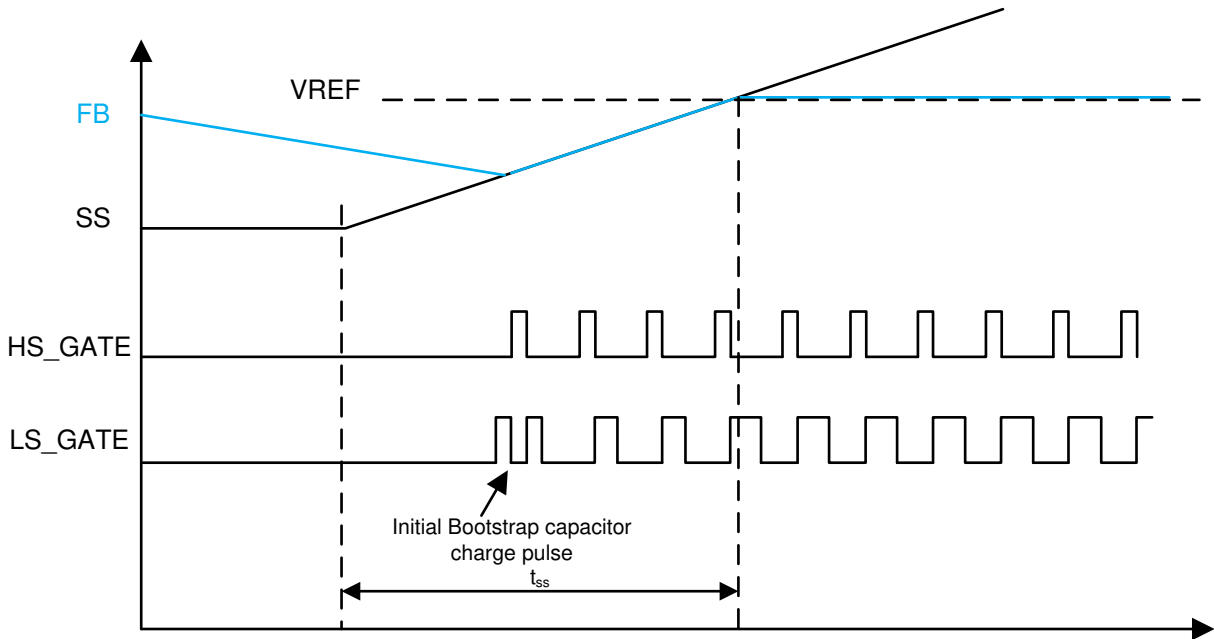

Figure 8-6. Soft-Start Under Prebiased Condition and DCM Mode Programmed

### 8.3.3.1 Analog Soft-Start (Default) and Digital Soft-Start

The TPS65400 has the ability to use an analog-based soft-start ramp based on external capacitors (one input for each switcher) or to use internal signals based on digital logics and DACs to perform the soft-start function.

When using external soft-start configuration (default configuration), the SSx pins are connected to the soft-start input of the error amplifier.

When using the internal digital soft-start signal, the soft-start input to the error amplifier increases step-by-step at a rate set according to the value set in TON\_RAMP\_RATE (see [\(DEh\) TON\\_TRANSITION\\_RATE](#)).

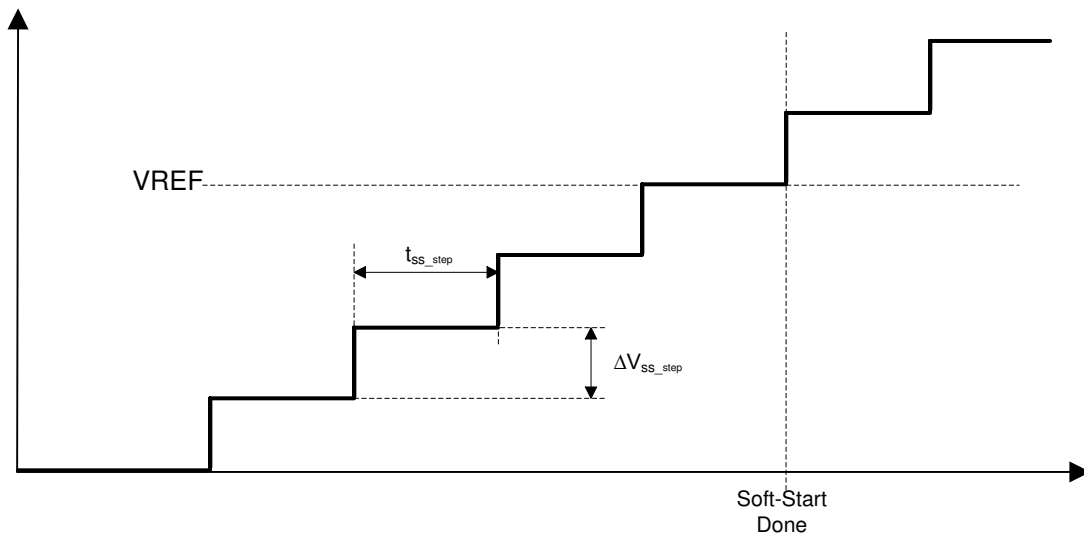

Figure 8-7. Internal Soft-Start Input to Error Amplifier When Digital Soft-Start is Selected

$\Delta V_{SS\_step}$  is 10 mV.  $t_{SS\_step}$  depends on the soft-start time option selected. See [\(DEh\) TON\\_TRANSITION\\_RATE](#) for more details.

### 8.3.3.2 Soft-Start Capacitor Selection

When using external soft-start capacitor to set the soft-start time, use [Equation 2](#).

$$t_{ss} = \frac{C_{ss}}{I_{ss}} \times V_{ref} \quad (2)$$

$C_{ss}$  is the value of the capacitor connected between the SSx pin and AGND.  $V_{REF}$  is the value of the reference voltage (default is 0.8 V).  $I_{SS}$  is the current sourced by the SS1/PG1 pin during soft-start.

### 8.3.4 PWM Switching Frequency Selection

The master clock frequency,  $F_{OSC}$ , can be set by external resistor on the RCLOCK\_SYNC terminal, or by synchronizing with an external clock. To set using an external resistor, use this formula.

$$F_{sw} \text{ (kHz)} = 138664 R_{OSC} \text{ (k}\Omega\text{)}^{-0.948} \quad (3)$$

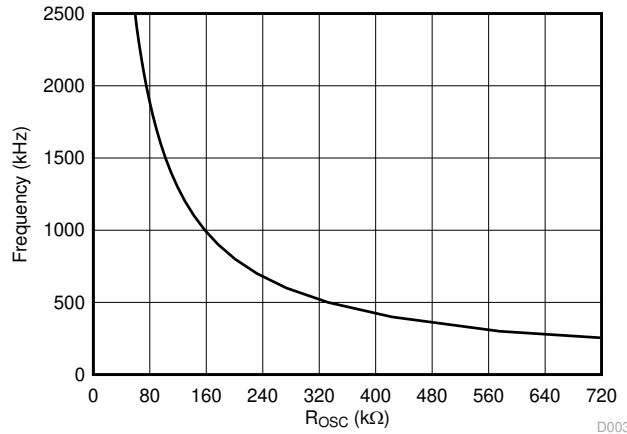

**Figure 8-8. Frequency vs  $R_{OSC}$**

To sync to an external source, an AC-coupled signal should be applied to the terminal. A fixed resistor should still be connected to set a minimum frequency. The frequency of the input signal to synchronize with should always be higher than the minimum frequency. If the internal PLL cannot synchronize, the switchers will fall back to the minimum frequency set by the resistor. The CLK\_OUT terminal outputs the master clock  $F_{OSC}$ .

The PWM frequency of each switcher is determined by this master clock frequency and an I<sup>2</sup>C-programmable choice of 4 divider ratios (1, 2, 4, or 8) by setting CLK\_DIV (see [\(D7h\) FREQUENCY\\_PHASE](#)).

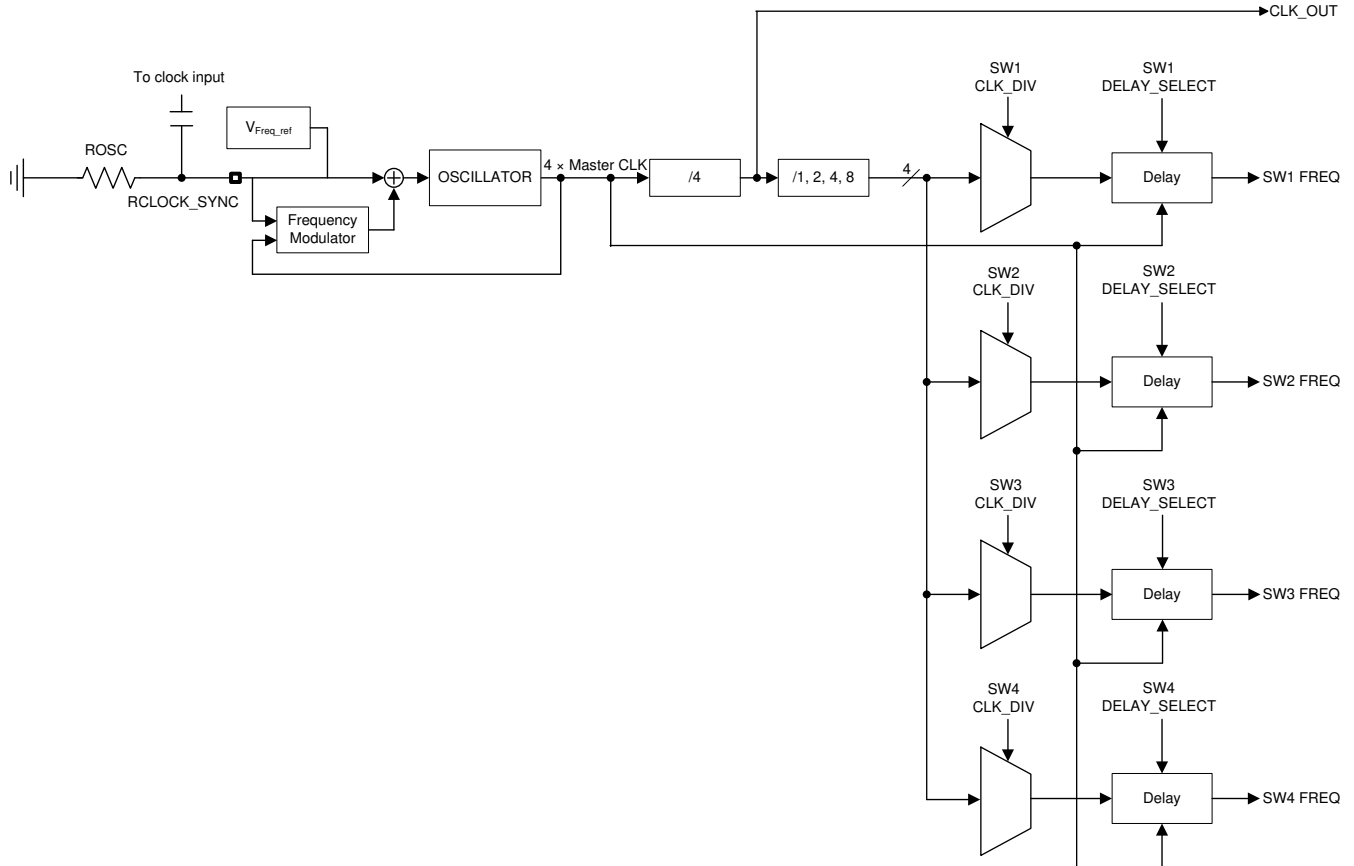

A. The frequency modulator is used for external clock synchronization.

**Figure 8-9. Diagram of PWM Clock Generation**

The intent of the individual divider ratios is to allow users to set the frequency of each switcher independently. For example, with a master clock  $F_{OSC}$  of 1.1 MHz, SW1 and SW2 have a divider ratio of 4 for a 275-kHz PWM, and SW3 and SW4 have a divider ratio of 1 for a PWM frequency of 1.1 MHz. Select the divider ratio so that the PWM frequency stays within the range of 275 kHz to 2.2 MHz for whichever master clock frequency is set.

In addition to selecting the frequency, each switcher can have its PWM frequency delayed. This enables the designer to minimize ripple current by properly selecting the delays so that the switching frequencies are out of phase. The default switching frequency is at  $CLK\_DIV = F_{OSC} / 1$  with PHASE\_DELAY for SW1 at  $0^\circ$ , SW2 at  $180^\circ$ , SW3 at  $90^\circ$ , and SW4 at  $270^\circ$ . More information on frequency selection and delay is given in (D7h) FREQUENCY\_PHASE.

### 8.3.5 Clock Synchronization

The RCLOCK\_SYNC terminal can be used to synchronize the master clock switching frequency,  $F_{OSC}$ , with an external clock source or another TPS65400. The external clock signal (which can come from another TPS65400 CLK\_OUT terminal) should be AC coupled to the RCLOCK\_SYNC terminal as shown in Figure 8-10. Choose the ROsc value so that the fixed frequency is nominally 30% lower than the external synchronizing clock frequency. An internal protection diode clamps the low level of the synchronizing signal to approximately  $-0.5$  V. The internal clock synchronizes to the rising edge of the external clock.

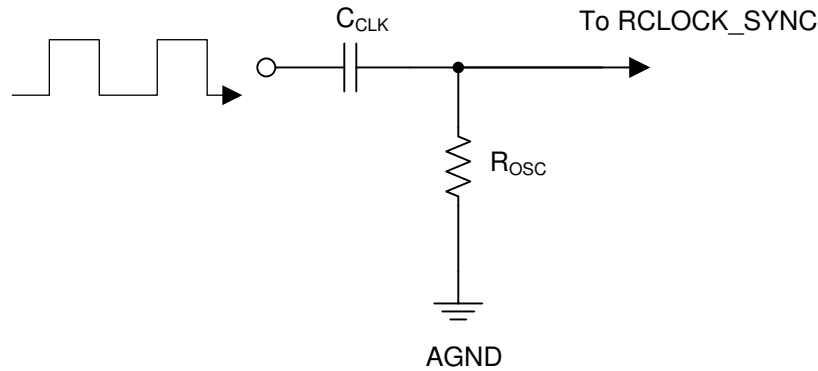

**Figure 8-10. AC-Coupled Clock Synchronization**

TI recommends to choose an AC-coupling capacitance in the range of 50 to 100 pF. Exceeding the recommended capacitance may inject excessive energy through the internal clamping diode structure present on the RCLOCK\_SYNC terminal. The typical trip level of the synchronization terminal is 1.5 V. To ensure proper synchronization and to avoid damaging the IC, the peak-to-peak value (amplitude) should be between 2.5 V and  $V_{DDA}$ . The minimum duration of this pulse must be greater than 200 ns, and its maximum duration must be 200 ns less than the period of the switching cycle.

The external clock synchronization process begins after the TPS65400 is enabled and an external clock signal is detected. The frequency modulator adjusts the oscillator frequency to match the frequency of the pulses into the RCLOCK\_SYNC terminal. It generally takes 50 cycles before the PWM frequency locks. If the external clock signal is removed after frequency synchronization, the master clock  $F_{OSC}$  drifts to the frequency selected by ROsc.

### 8.3.6 Phase Interleaving

The TPS65400 offers the ability to output rails of higher currents by connecting SW1 and SW2 in parallel, or by connecting SW3 and SW4 in parallel. To configure this option, the COMP2 or COMP4 terminal must be tied to VDDA through a 1-k $\Omega$  resistor.

Upon the initialization sequence after a reset, the TPS65400 attempts to discharge the COMP terminal through a 2-k $\Omega$  internal resistor. When it detects that the COMP terminal is pulled high, it configures itself to operate in current sharing mode. If SW2 is set to current sharing mode, its PWM output is controlled by the error amplifier and COMP1 terminal of SW1 and set to the same frequency as SW1. Likewise, if SW4 is set to current sharing mode, its PWM output is controlled by the error amplifier and COMP3 terminal of SW3 and set to the same frequency as SW3. This means that the frequency settings for SW2 and SW4 in the EEPROM are ignored in that mode of operation.

When current sharing mode is detected on a particular pair, the output slave's I<sup>2</sup>C access is invalid and the output slave's default settings follow that of its master (see (00h) PAGE). The only exception is that the slave switcher PWM is a fixed 180° phase-shift from its master.

**Table 8-1. Programmable Options When Current Sharing Enabled**

Pair	Output	Current Sharing Relationship	Switching Frequency	Switching Phase
SW1-SW2	SW1	Master	Programmable	Programmable
	SW2	Slave	Follows master	Master + 180°
SW3-SW4	SW3	Master	Programmable	Programmable
	SW4	Slave	Follows master	Master + 180°

### 8.3.7 Fault Handling

OVP, OCP, and undervoltage protection (UVP) are handled for each switcher independently. OVP or OCP faults that occur on one switcher do not affect the other outputs. There are two exceptions:

- If current-sharing mode (ISHARE) is detected for a switcher that faults, both switchers in parallel have the same response to OVP or OCP.

- When using internal sequencing, in the case of faults occurring during the initial power-up sequence, all switchers are disabled for 500 ms, after which, the startup sequence is restarted.

During the soft-start time for a switcher, all fault signals (OVP, OCP, and UVP) are disabled and reset to the unfaulted condition. The first moment when faults can be triggered is after the end of the soft-start sequence.

OVP thresholds are set as a percentage of VREF. A deglitching time of 50  $\mu$ s is used for the overvoltage. When an overvoltage occurs at the OVP upper threshold limit, the high-side FET and the low-side FET are disabled for that switcher until the OVP falling threshold is reached. When the OVP falling threshold is reached, the low-side FET turns on for 200 ns to ensure that the bootstrap capacitor is recharged before resuming normal operation of the converter.

Output voltage falling below the UVP thresholds causes the corresponding PGOOD output to fall, but the switcher continues to operate as it tries to increase the output voltage. However, if the PGOOD terminal is tied to the enable ENSWx signal of another switcher on the PCB (for external sequencing), the output for that ENSWx-PGOOD-tied switcher is disabled until output voltage is nominal and PGOOD is good.

OTP shuts down all switchers. When the temperature drops below the hysteresis level, a soft reset is triggered and the chip restarts from the startup sequence.

[Section 8.5.2.4](#) describes fault reporting and clearing of fault status registers.

The OVP and UVP sensing is deglitched to prevent unwanted tripping. The faults need to be sustained for more than 55  $\mu$ s typically (60  $\mu$ s max) to be registered and trigger protection circuits and PGOOD output to fall. Fault detection is disabled on a given switcher when its VREF is being ramped (as result of an I<sup>2</sup>C command to change VREF). An additional 100- $\mu$ s fault blanking time results after VREF has been adjusted to its target level.

### 8.3.8 OCP for SW1 to SW4

The OCP is I<sup>2</sup>C-programmable and set by the IOOUT\_MAX command. By default, the peak current IOOUT\_MAX for SW1 and SW2 is 6 A, and for SW3 and SW4 it is 3 A. When the current reaches this threshold, the unit immediately turns off the high-side FET and keeps the low-side FET off for the remainder of the switching cycle. The following cycle are skipped (high-side FET off, low-side FET off) regardless of the inductor current. If the current in the inductor is still higher than the IOOUT\_MAX after the skipped cycle, the following cycles are also skipped until the current reach below the IOOUT\_MAX.

If the IOOUT\_MAX is reached more than 256 active cycles continuously, the switcher shut downs for 20 ms and restarts. If the switcher is running in interleaved operation, both the switcher that tripped the IOOUT\_MAX threshold and its interleaved counterpart shut down for 20 ms. After that period of time, the unit restarts and goes through soft-start operation. For very-low duty cycle operation and faulty operation with very-fast current increase during the high-side FET on-time (due to inductor saturation and so forth), OCP is also enforced on the low side to ensure no runaway condition exists.

**Table 8-2. Current Limit Options**

SWITCHER	IOOUT_MAX
SW1, SW2	2 A
	3 A
	4 A
	5 A
	6 A (default)
SW3, SW4	0.5 A
	1 A
	2 A
	3 A (default)

While the converter is shut down following an OCP event spanning more than 256 cycles, the COMP terminal is pulled low for 1.1 ms prior to precharge and re-enabling of the converter. At the same time, the SSx pin is

discharged to AGND for 1.1 ms. If the soft-start is digital (SSx pins used as PGOODx outputs), the soft-start value is reset.

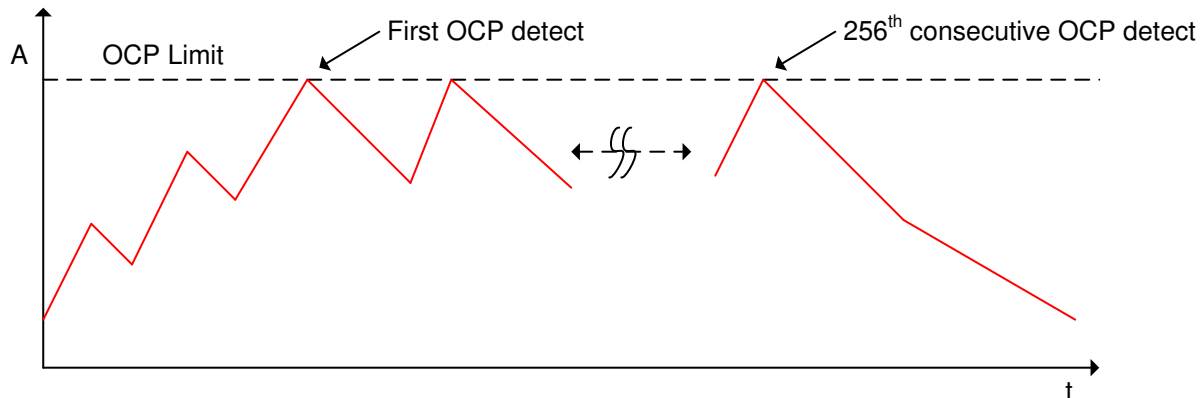

**Figure 8-11. Inductor Current During Overcurrent Event**

At high switching frequency (>1 MHz) and particularly when there is a fault in the converter such as saturation of the inductor, the current sensor might not sense the overcurrent event. To ensure that current protection is provided in all operating scenarios, low-side current sensing is also present to provide overcurrent detection and protection when the low-side FET is on. If over-current is detected when the low-side FET is on, the low-side FET stays on (and the high-side FET off) until the current drops below the threshold. A new cycle will then begin (high side on, low side off) when the next switching cycle occurs as driven by the internal clock derived from the oscillator (internal or external synchronization). A dedicated counter records the low-side OCP events and initiates a shutdown of the converter after 256 OCP event counts. Six consecutive cycles without a low-side OCP event resets the counter.

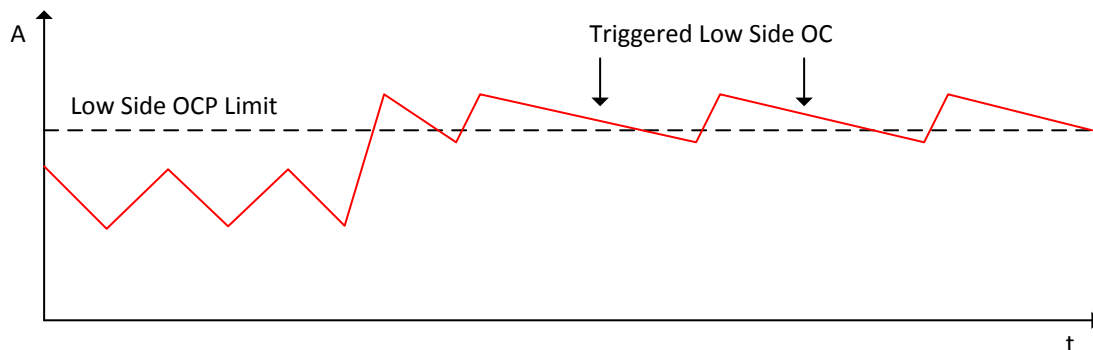

**Figure 8-12. Inductor Current During Overcurrent Event With Low-Side Detection**

### 8.3.9 Overcurrent Protection for SW1 to SW4 in Current Sharing Operation

When the converter is running in interleaved operation, an OCP event will not trigger the COMP terminal to be pulled low to 0.6 V. Instead, the error amplifier is switched off (tri-stated). This ensures that the COMP terminal voltage remains constant so that the other phase continues to operate during the OCP event. An OCP event on one switcher lasting more than 256 cycles triggers the shutdown of both switchers running in interleaved mode.

### 8.3.10 Recovery on Power Loss

All contents of the registers are saved and stored in the data store (non-volatile memory) with the exceptions listed in [Table 8-6](#) (Supported PMBus Commands) when STORE\_DEFAULT\_ALL is issued. Contents of the registers are copied from the data store when power is restored. This allows the system processor to turn on the power supplies as needed with the same default settings before power was lost.

### 8.3.11 Feedback Compensation

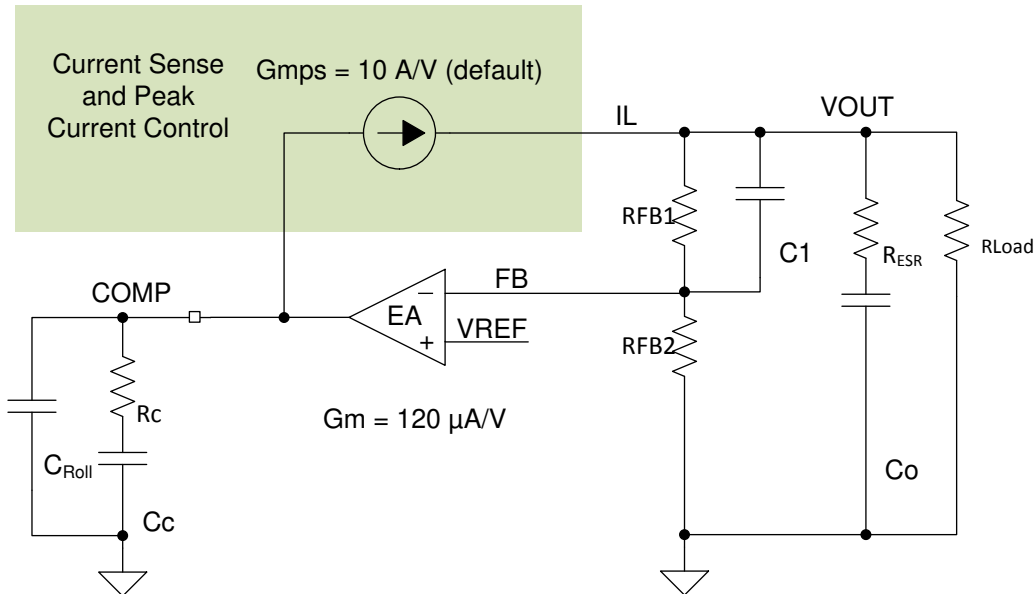

**Figure 8-13. Simplified Equivalent Feedback Compensation Network**

A typical compensation circuit could be type II ( $R_C$  and  $C_C$ ) to have a phase margin between  $60^\circ$  and  $90^\circ$ , or type III ( $R_C$ ,  $C_C$ , and  $C_{ff}$ ) to improve the converter transient response.  $C_{Roll}$  adds a high-frequency pole to attenuate high-frequency noise when needed.  $C_{Roll}$  should be set to at least twice the crossover frequency to avoid interacting with the feedback compensation. It may also prevent noise coupling from other rails if there is possibility of cross coupling in between rails when layout is very compact.

Table 8-3 shows the recommended values for the compensation network components as an initial start. These result in the compensating zero of the Type II to match the dominant pole of the converter.

**Table 8-3. Compensation Calculation Table**

	TYPE II	TYPE III
Select cross over frequency to be less than 1/5 of switching frequency (typical is 1/10)	$F_C = \frac{F_{SW}}{10}$	$F_C = \frac{F_{SW}}{10}$
Set $R_C$	$R_C = \frac{2\pi \times F_C \times V_{OUT} \times C_O}{G_m \times G_{m_{PS}} \times V_{REF}}$	$R_C = \frac{2\pi \times F_C \times C_O}{G_m \times G_{m_{PS}}}$
Set $C_C$	$C_C = \frac{R_{LOAD} \times C_O}{R_C}$	$C_C = \frac{R_{LOAD} \times C_O}{R_C}$
Add $C_{Roll}$ if needed to remove large signal coupling to high impedance COMP node.	$C_{Roll} = \frac{R_{esr} \times C_O}{R_C}$	$C_{Roll} = \frac{R_{esr} \times C_O}{R_C}$
$C_{ff}$ compensating capacitor for type III compensation network. Choose $f_{z_{ff}}$ same as $F_C$ .	N/A	$C_{ff} = \frac{1}{2\pi \times f_{z_{ff}} \times R_{FB1}}$

### 8.3.12 Adjusting Output Voltage

The output voltage of each buck is set with a resistor divider from BUCK output to FB pin and ground. TI recommends to use a 1% tolerance resistor or better one to get higher output voltage accuracy.

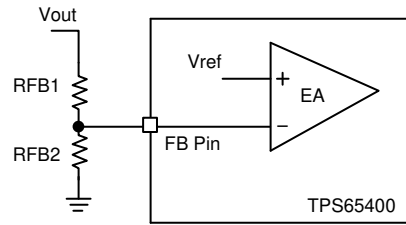

**Figure 8-14.**

With RFB1 and RFB2, output voltage is determined by:

$$V_{out} = V_{ref} \times \left( 1 + \frac{R_{FB1}}{R_{FB2}} \right) \quad (4)$$

Default Vref in TPS65400 is 0.8 V. It can be programmed from 0.6 to 1.87 V by digital interface PMBus. See (D8h) [VREF\\_COMMAND](#) for more detailed information.

### 8.3.13 Digital Interface – PMBus

TPS65400 implements a PMBus-compatible I<sup>2</sup>C digital interface. The PMBus specification referenced by this section is *PMBus Power System Management Protocol Specification Part I – General Requirements, Transport and Electrical Interface*, Revision 1.2, dated 6 September 2010. The specification is published by the Power Management Bus Implementers Forum and is available from <http://pmbus.org/Specifications>. See details in [Section 8.5.1](#) and [Section 8.6](#).

### 8.3.14 Initial Configuration

The recommended method of configuring the TPS65400 the first time is through an external programmer through a separate I<sup>2</sup>C programming header (as shown in [Figure 8-15](#)). The programming header needs to connect to the SCL, SDA, CE, VDDD, and DGND lines, and can be done using a USB-to-I<sup>2</sup>C tool. This enables the user to tailor the settings of the TPS65400 for each PCB specifically after PCB assembly, before the first power-up of the board.

An alternative method is to use the firmware in an on-board microcontroller to do the initial configuration. To do this, the user has two options:

- Power the microcontroller and the TPS65400 (VDDD, CE, and DGND connections needed) from an external source not controlled by the TPS65400.
- Design the PCB so that the default settings of the TPS65400 allow the microcontroller to be powered when power is applied to the TPS65400 the first time. The designer also needs to ensure that the default power-up sequence, ramp-rates, and other default parameters do not damage any components when power is applied the first time. After configuration, the microcontroller should pull CE low, and then all future power-ups result in the newly configured power-up scheme to occur.

Using either method for the microcontroller requires the firmware to check if the TPS65400 has been previously configured, or if a modification needs to be made to an already programmed configuration. Users may use USER\_DATA\_BYTE\_00 and/or USER\_DATA\_BYTE\_01 to store a version number to identify which version of the configuration is stored in the TPS65400.

A hybrid option may also be done where the initial configuration is done using an external programmer, and the subsequent revisions are done through the microcontroller firmware. This eliminates the risk from damage caused by the default configuration during the first power-up, but still allows the microcontroller firmware to modify settings such as the VREF settings for subsequent power-ups.

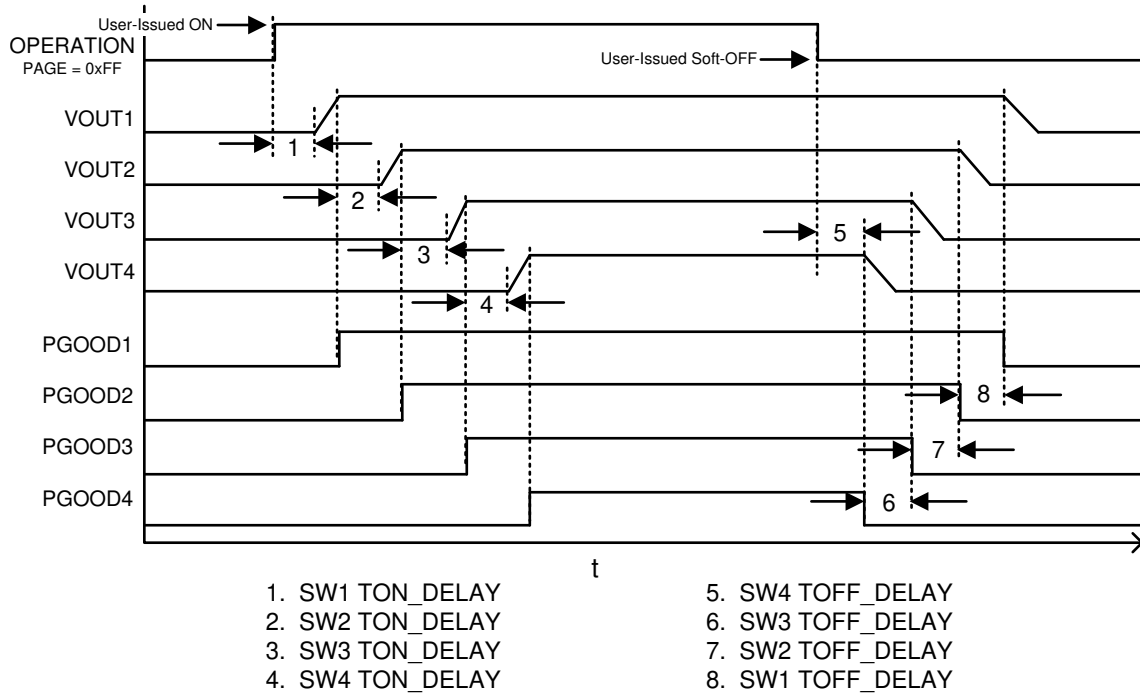

A. Configuration:

1. Enable pins ENSWx set to inactive in PIN\_CONFIG\_00
2. Start sequence order SW1-SW2-SW3-SW4 in SEQUENCE\_ORDER
3. Stop sequence order SW4-SW3-SW2-SW1 in SEQUENCE\_ORDER

**Figure 8-15. Example of Internal On Sequencing and Off Sequencing With the Default START\_PGOOD Dependence**

OPERATION (SWx) refers to OPERATION register in the corresponding PMBus PAGE. See (01h) OPERATION for more information on the OPERATION register.

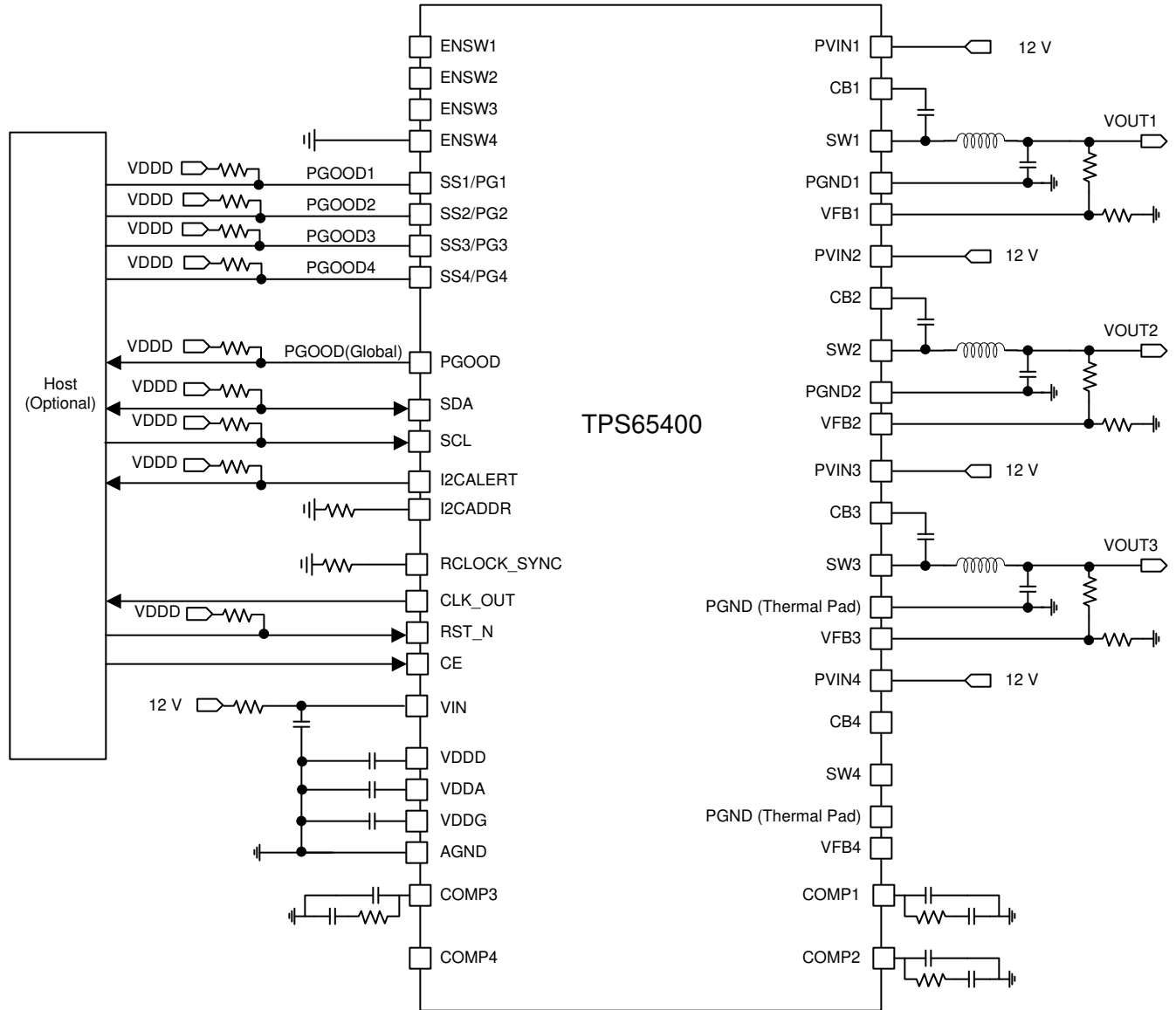
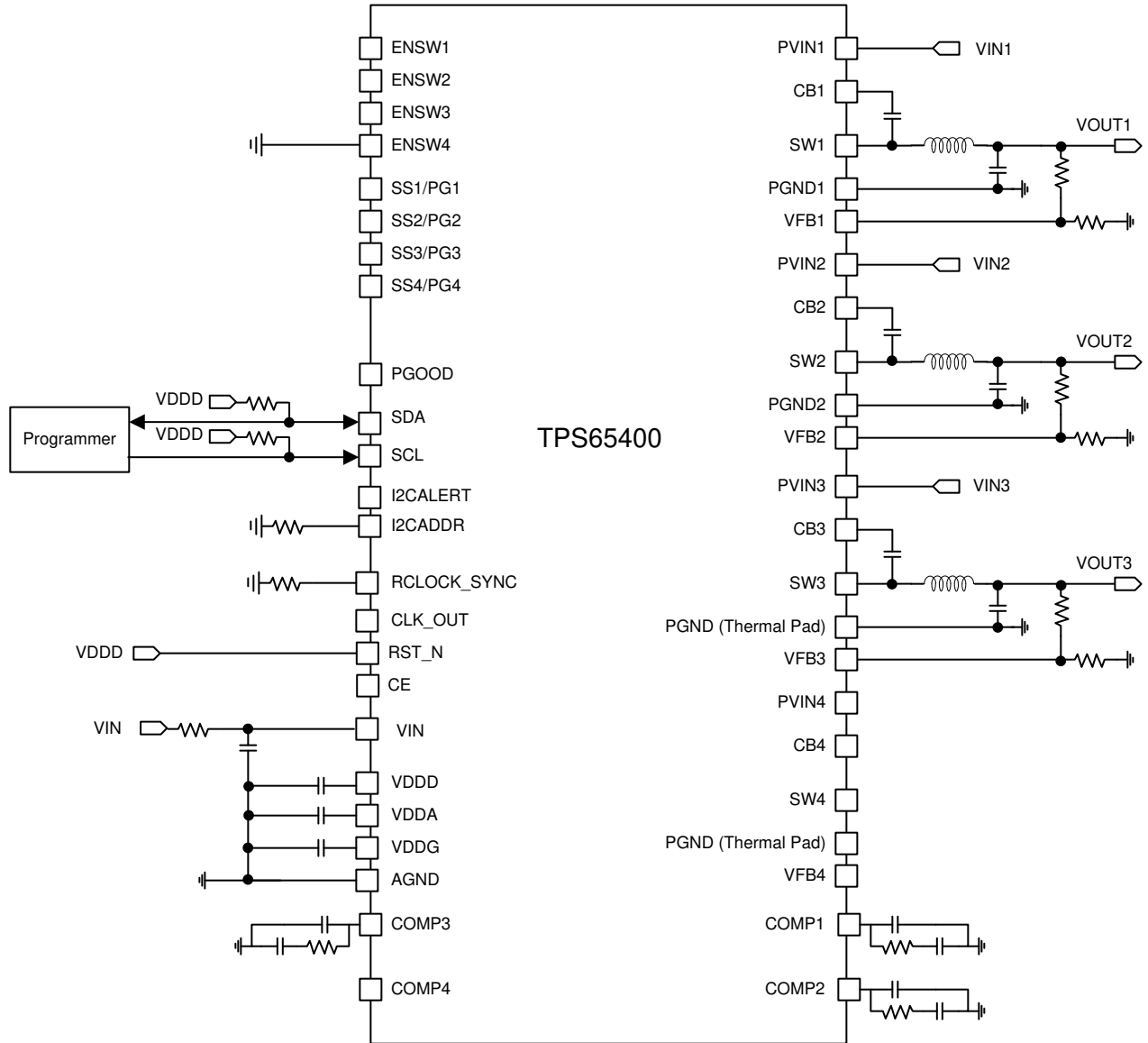

Figure 8-16. Internal Sequencing Schematic With Host



**Figure 8-17. Internal Sequencing Schematic Without Host**

## 8.4 Device Functional Modes

### 8.4.1 CCM Operation Mode

When the VIN/PVINx are above UVLO threshold and ENSWx are above the threshold, all four switchers operate in continuous current mode (CCM) with IOUT\_MODE (see [\(D6h\) IOUT\\_MODE](#)) setting default. In CCM, the converters work in peak current mode for easy loop compensation and cycle-by-cycle high side MOSFET current limit.

### 8.4.2 CCM/DCM Operation Mode

When DCM mode is enabled by setting IOUT\_MODE (see [\(D6h\) IOUT\\_MODE](#)), the switchers transition to DCM operation at light loads. During DCM mode, the low-side FET is turned off to prevent negative inductor current. This increases light-load efficiency, but output ripple and transient response during DCM or during transitions between DCM and CCM mode can be degraded.

At light load, the COMP terminal is driven by the error amplifier to the minimum clamp voltage. When the COMP voltage reaches below 0.6 V and the error amplifier is sinking more than 5  $\mu\text{A}$ , both the high-side and low-side FET will be tri-stated to prevent the output voltage from rising above the set value. The FET function is re-enabled when the GM amplifier sinks less than 3  $\mu\text{A}$ . This results in a burst mode operation at light load. The low-side FET has a 200-ns one-shot ON-time to ensure that the bootstrap capacitor is charged before the normal function of the converter is resumed.

### 8.4.3 Current Sharing Mode

When SW1/SW2 pair output and/or SW3/SW4 pair output are shared, the responding pairs current sharing mode is enabled and the ENABLE\_PIN\_CONFIG is set to single ENABLE. For the detail configuration, see [Section 9.2.2](#).

## 8.5 Programming

### 8.5.1 PMBus

#### 8.5.1.1 Overview

The TPS65400 implements a lightweight PMBus-compliant layer supporting packet error checking, high-speed bus, and group commands.

#### 8.5.1.2 PMBus Protocol

The PMBus specification follows SMBus version 2.0. [Figure 8-18](#) through [Figure 8-25](#) show all supported command transactions.

##### 8.5.1.2.1 PMBus Protocol

**Figure 8-18. Send Byte Protocol With PEC**

1	7	1	1	8	1	8	1	1
Start	Slave address	Wr	Ack	Command code	Ack	PEC	Ack	Stop

**Figure 8-19. Write Byte Protocol With PEC**

1	7	1	1	8	1	8	1	8	1	1
Start	Slave address	Wr	Ack	Command code	Ack	Data byte	Ack	PEC	Ack	Stop

**Figure 8-20. Read Byte Protocol With PEC**

1	7	1	1	8	1	1	1
Start	Slave address	Wr	Ack	Command code	Ack	Restart	
7	1	1	8	1	8	1	1
Slave address	Rd	Ack	Data byte	Ack	PEC	Nack	Stop

**Figure 8-21. Read Word Protocol With PEC**

1	7	1	1	8	1	1	7	1	1
Start	Slave address	Wr	Ack	Command code	Ack	Restart	Slave address	Rd	Ack
8	1	8	1	8	1	1	1		
Data word (low)	Ack	Data word (high)	Ack	PEC	Nack	Stop			

##### 8.5.1.2.2 Transactions (No PEC)

**Figure 8-22. Send Byte Protocol**

1	7	1	1	8	1	1
Start	Slave address	Wr	Ack	Command code	Ack	Stop

**Figure 8-23. Write Byte Protocol**

1	7	1	1	8	1	8	1	1
Start	Slave address	Wr	Ack	Command code	Ack	Data byte	Ack	Stop

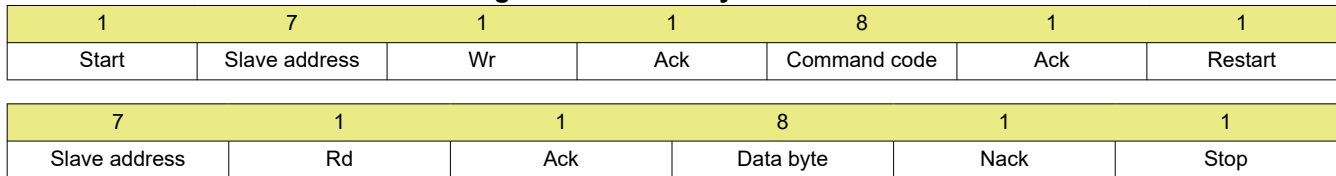
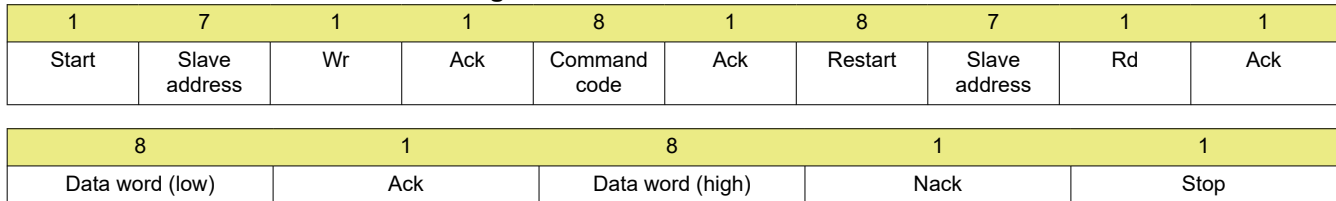
**Figure 8-24. Read Byte Protocol****Figure 8-25. Read Word Protocol****8.5.1.2.3 Addressing**

The 7-bit I<sup>2</sup>C address is set through the I2CADDR terminal with a resistor RADDR connected to AGND. Table 8-4 shows the connection between the voltage at the I2CADDR terminal and the set I<sup>2</sup>C address at V<sub>DD</sub> = 3 V. The I<sup>2</sup>C address is determined only upon startup during t<sub>RESET\_DELAY</sub> after rising edge of CE or RST\_N. This makes it immune to noise that may occur during normal operation. TI recommends resistors with 5% or lower tolerance. If I<sup>2</sup>C is not necessary in the application, TI recommends to tie the I2CADDR terminal directly to VDD.

**Table 8-4. I<sup>2</sup>C Address Selection**

R <sub>ADDR</sub>	7-BIT ADDRESS
180 kΩ	1101 111
120 kΩ	1101 110
82 kΩ	1101 101
56 kΩ	1101 100
39 kΩ	1101 011
22 kΩ	1101 010
10 kΩ	1101 001
2 kΩ	Test mode (factory-use only)

**8.5.1.2.4 Startup**

After CE is asserted and V<sub>DD</sub> has reached 3.3 V, there is approximately a 320 μs delay before the PMBus interface is active. During this time the TPS65400 is restoring its configuration from the EEPROM.

**8.5.1.2.5 Bus Speed**

100- and 400-kHz bus speeds are supported.

**8.5.1.2.6 I2CALERT Terminal**

When a timeout condition occurs, the I2CALERT terminal is pulsed low for 200 μs. A timeout condition is defined as per SMBUS 2.0, t<sub>TIMEOUT</sub>. In addition to SCL, a timeout condition also occurs when the SDA line is asserted low. If the timeout condition persists, I2CALERT continues to pulse every t<sub>TIMEOUT</sub>. The TPS65400 never intentionally pulls the SCL low beyond t<sub>LOW:SEXT</sub><sup>1</sup>, as that violates timing specifications. Therefore, the I2CALERT terminal acts as a watchdog for other devices sharing the same bus that violate the cumulative clock low extend time. On a system level, it can be seen as a non-maskable interrupt (NMI) signal for the I<sup>2</sup>C bus.

<sup>1</sup> t<sub>LOW:SEXT</sub>: Cumulative clock low extend time (slave device). See more details on SMBus specification <http://smbus.org/specs/>.

**Table 8-5. Timeout Specifications**

PARAMETER		MIN	MAX	UNIT
t <sub>TIMEOUT:SCL</sub>	Detect clock low timeout	25	35	ms
t <sub>TIMEOUT:SDA</sub>	Detect data low timeout	25	35	ms

#### 8.5.1.2.7 CONTROL Terminal

The TPS65400 enable terminals ENSW<sub>x</sub> are equivalent to the CONTROL terminals in the fault handling. The enable terminals behave as follows:

- Unit does not power up until commanded by the enable terminal and OPERATION command. By default, the OPERATION command is ON, so the powering up of the unit depends on the enable terminal state.
- To start, the unit requires that the on/off portion of the OPERATION command is instructing the unit to run. Depending on PIN\_CONFIG\_00, the unit may also require the enable terminal to be asserted for the unit to start and energize the output.
- Polarity of the enable terminal is active high. If unconnected, the terminal goes high.
- When commanding the unit to turn on or off through the enable terminals, the programmed turn on delays, turn off delays are always observed.

There are differences in enable terminal functionality depending on terminal configuration PIN\_CONFIG\_00. For more information, refer to OPERATION and PIN\_CONFIG\_00.

#### 8.5.1.2.8 Packet Error Checking

The TPS65400 supports an optional PEC code to be validated at the end of every write and to be appended to the end of every read. TI highly recommends it, but it is not required.

#### 8.5.1.2.9 Group Commands

Fully-compliant group commands are supported.

#### 8.5.1.2.10 Unsupported Features

All undocumented, optional features are not supported. Extended commands are not supported.

### 8.5.2 PMBus Register Descriptions

The PMBus specification referenced by this section is *PMBus Power System Management Protocol Specification Part II – Command Language, Revision 1.2*, dated 6 September 2010. The specification is published by the Power Management Bus Implementers Forum and is available from <http://pmbus.org/specifications>.

#### 8.5.2.1 Overview

The following parameters can be programmed and read. These are individually available for each power supply output (SW1-SW4):

- Voltage reference
- Start sequencing
- Stop sequencing
- Switching frequency
- Switching phase
- Soft-start time
- Current limit
- Current sharing operation with SW1-SW2 and/or SW3-SW4 pairs
- Power Good
- Fault status

Each power supply has its own set of PMBus commands. Paging is supported to allow device selection for a PMBus session ((00h) PAGE). [Table 8-6](#) lists supported PMBus commands and paging values.

### 8.5.2.2 Memory Model

*Supported PMBus Commands* describes the memory model for PMBus devices. Values used by the PMBus device are loaded into volatile operating memory from the following places:

- Values hard-coded into an IC design
- Values programmed from hardware terminals
- A non-volatile memory called the default store
- Communications from the PMBus

On-board data flash memory is used to implement the hard-coded values and the default store values. Values in the default store may be changed using the STORE\_DEFAULT\_ALL command described in (11h) [STORE\\_DEFAULT\\_ALL](#). The user store is not supported. [Table 8-6](#) describes the ordering of memory loading and precedence. In general, the hard-coded parameters are loaded into operating memory first. Second, any terminal-programmable settings take effect. Third, values from the default store are loaded. Later, commands issued from the PMBus take effect. In all cases, an operation on a parameter overwrites any prior value that was already in the operating memory.

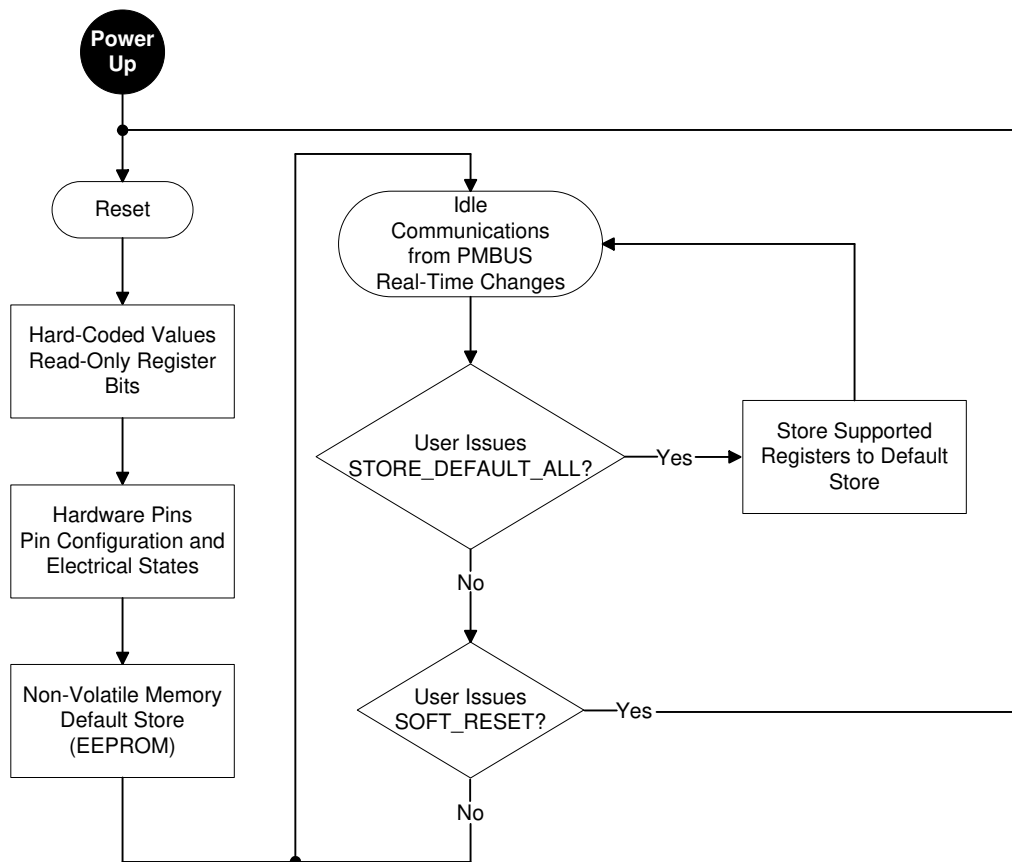

Figure 8-26. Memory Model

### 8.5.2.3 Data Formats

Data is sent as a byte, an 8-bit binary value, a word, a 16-bit binary value, or a block of bytes whose length is specified by a length byte.

### 8.5.2.4 Fault Monitoring

Registers [\(78h\) STATUS\\_BYTE](#), [\(79h\) STATUS\\_WORD](#), [\(7Ah\) STATUS\\_VOUT](#) of the PMBus specification describe fault monitoring for PMBus devices. The TPS65400 only supports reporting faults. Fault conditions are set in the corresponding status register and the host or power system manager can poll it. Any bits set in the status register remain set even if the fault condition is removed or corrected. The fault bits in the status register remain set until one of the following occur:

- The device receives a CLEAR\_FAULTS command.
- A RESET signal is asserted by either issuing a SOFT\_RESET or by asserting/deasserting the CE terminal.
- Bias power is removed from the PMBus device.

[Section 8.3.7](#) describes fault thresholds and specific response behaviors.

## 8.6 Register Maps

Table 8-6 lists the PMBus commands. Commands 00h through CFh are defined in the *PMBus Specification* and are considered to be core commands that are standardized for all manufacturers and products. Commands D0h through FEh are manufacturer-specific and may be unique for each manufacturer and product. Commands that are not supported by the device are not listed.

**Table 8-6. Supported PMBus Commands**

CODE	NAME	SMBUS TRANSACTION TYPE: WRITING DATA	SMBUS TRANSACTION TYPE: READING DATA	DATA BYTES	PAGE SUPPORT	SAVED TO DATA FLASH	DESCRIPTION
00h	PAGE	Write byte	Read byte	1	—	No	Selects output rail (see <a href="#">(00h) PAGE</a> )
01h	OPERATION	Write byte	Read byte	1	00-03, FF	No	Starts or stops output (see <a href="#">(01h) OPERATION</a> )
03h	CLEAR_FAULTS	Send byte	—	0	00-03, FF	—	Clears all faults (see <a href="#">(03h) CLEAR_FAULTS</a> )
10h	WRITE_PROTECT	Write byte	Read byte	1	—	No	Used to lock bus writes (see <a href="#">(10h) WRITE_PROTECT</a> )
11h	STORE_DEFAULT_ALL	Send byte	—	0	—	—	Stores operating memory to default store (see <a href="#">(11h) STORE_DEFAULT_ALL</a> )
19h	CAPABILITY	—	Read byte	1	—	—	Describes PMBUS capabilities (see <a href="#">(19h) CAPABILITY</a> )
78h	STATUS_BYTE	—	Read byte	1	00-03, FF	—	Fault register (see <a href="#">(78h) STATUS_BYTE</a> )
79h	STATUS_WORD	—	Read word	2	00-03, FF	—	Fault register (see <a href="#">(79h) STATUS_WORD</a> )
7Ah	STATUS_VOUT	—	Read byte	1	00-03, FF	—	Output fault register (see <a href="#">(7Ah) STATUS_VOUT</a> )
80h	STATUS_MFR_SPECIFIC	—	Read byte	1	—	—	Status register (PGOOD#_N) (see <a href="#">(80h) STATUS_MFR_SPECIFIC</a> )
98h	PMBUS_REVISION	—	Read byte	1	—	—	PMBUS revision support (see <a href="#">(98h) PMBUS_REVISION</a> )
ADh	IC_DEVICE_ID	—	Read block	7	—	—	IC part number in ASCII (see <a href="#">(ADh) IC_DEVICE_ID</a> )
A Eh	IC_DEVICE_REV	—	Read block	2	—	—	IC part revision code (see <a href="#">(A Eh) IC_DEVICE_REV</a> )
D0h	USER_DATA_BYTE_00	Write byte	Read byte	1	—	Yes	User-defined data (see <a href="#">(D0h) USER_DATA_BYTE_00</a> )
D1h	USER_DATA_BYTE_01	Write byte	Read byte	1	—	Yes	User-defined data (see <a href="#">(D1h) USER_DATA_BYTE_01</a> )
D2h	PIN_CONFIG_00	Write byte	Read byte	1	—	Yes	Configures pin behavior (see <a href="#">(D2h) PIN_CONFIG_00</a> )

**Table 8-6. Supported PMBus Commands (continued)**

CODE	NAME	SMBUS TRANSACTION TYPE: WRITING DATA	SMBUS TRANSACTION TYPE: READING DATA	DATA BYTES	PAGE SUPPORT	SAVED TO DATA FLASH	DESCRIPTION
D3h	PIN_CONFIG_01	Write byte	Read byte	1	00-03	Yes	Configures rail-specific pin behavior (see <a href="#">(D3h) PIN_CONFIG_01</a> )
D4h	SEQUENCE_CONFIG	Write byte	Read byte	1	—	Yes	Configures sequence behavior (see <a href="#">(D4h) SEQUENCE_CONFIG</a> )
D5h	SEQUENCE_ORDER	Write byte	Read byte	1	00-03	Yes	Configures sequence order (see <a href="#">(D5h) SEQUENCE_ORDER</a> )
D6h	IOUT_MODE	Write byte	Read byte	1	00-03	Yes	Sets CCM / DCM, current sharing status (see <a href="#">(D6h) IOUT_MODE</a> )
D7h	FREQUENCY_PHASE	Write byte	Read byte	1	00-03	Yes	Sets switcher frequency and phase (see <a href="#">(D7h) FREQUENCY_PHASE</a> )
D8h	VREF_COMMAND	Write byte	Read byte	1	00-03	Yes	Sets reference voltage ( $V_{REF}$ ) (see <a href="#">(D8h) VREF_COMMAND</a> )
D9h	IOUT_MAX	Write byte	Read byte	1	00-03	Yes	Sets current limit (see <a href="#">(D9h) IOUT_MAX</a> )
DAh	USER_RAM_00	Write byte	Read byte	1	—	No	RESET notification (see <a href="#">(DAh) USER_RAM_00</a> )
DBh	SOFT_RESET	Send byte	—	0	—	—	Soft resets device (see <a href="#">(DBh) SOFT_RESET</a> )
DCh	RESET_DELAY	Write byte	Read byte	1	—	Yes	Sets delay after reset (see <a href="#">(DCh) RESET_DELAY</a> )
DDh	TON_TOFF_DELAY	Write byte	Read byte	1	00-03	Yes	Sets delay before output begins to turn ON/OFF (see <a href="#">(DDh) TON_TOFF_DELAY</a> )
DEh	TON_TRANSITION_RATE	Write byte	Read byte	1	00-03	Yes	Sets soft-start time (see <a href="#">(DEh) TON_TRANSITION_RATE</a> )
DFh	VREF_TRANSITION_RATE	Write byte	Read byte	1	00-03	Yes	Sets ramping parameters for real-time Vref settings in output (see <a href="#">(DFh) VREF_TRANSITION_RATE</a> )
E0h to EFh	—	—	—	—	—	—	Reserved
F0h	SLOPE_COMPENSATION	Write byte	Read byte	1	00-03	Yes	Adjusts control loop compensation (see <a href="#">(F0h) SLOPE_COMPENSATION</a> )
F1h	ISENSE_GAIN	Write byte	Read byte	1	00-03	Yes	Adjusts control loop current sense (see <a href="#">(F1h) ISENSE_GAIN</a> )
FCh	DEVICE_CODE	—	Read word	2	—	—	IC part revision code (see <a href="#">(FCh) DEVICE_CODE</a> )

Table 8-7. Command Bit-Mapping

CODE	NAME	DEFAULT VALUE	BYTE	BITS								
				7 (MSB)	6	5	4	3	2	1	0 (LSB)	
00h	PAGE	0xFF	0	PAGE								
01h	OPERATION	0x80	0	OPERATION				x	x	x	x	
03h	CLEAR_FAULTS			—								
10h	WRITE_PROTECT	0x40	0	WRITE_PROTECT								
11h	STORE_DEFAULT_ALL			—								
19h	CAPABILITY	0xA0	0	PEC	BUS		SMB_ALERT	x	x	x	x	
78h	STATUS_BYTE	0b0XXX0XX	0	x	OFF	VOUT_OV	IOUT_OC	TEMPERATURE	x	CML	NONE OF THE ABOVE	
79h	STATUS_WORD	0b0XXX0XX	0	x	OFF	VOUT_OV	IOUT_OC	TEMPERATURE	x	CML	NONE OF THE ABOVE	
		0bX00X000	1	VOUT	x	x	MFR	POWER_GOOD_N	x	x	x	
7Ah	STATUS_VOUT	0bX00X000	0	VOUT_OV	x	x	VOUT_UV	x	x	x	x	
80h	STATUS_MFR_SPECIFIC	0b0000XXXX	1	x	x	x	x	POWER_GOOD4_N	POWER_GOOD3_N	POWER_GOOD2_N	POWER_GOOD1_N	
98h	PMBUS_REVISION	0x22	0	Part I Revision				Part II Revision				
ADh	IC_DEVICE_ID	0x07	0	Length								
		0x4C	1	'L'								
		0x4D	2	'M'								
		0x32	3	'2'								
		0x36	4	'6'								
		0x34	5	'4'								
		0x33	6	'3'								
		0x30	7	'0'								
AEh	IC_DEVICE_REV	0x02	0	Length								
		0xFF	1	DEVICE_CODE_ID				DEVICE_CODE_REV				
		0x00	2	DEVICE_CODE_ID								
D0h	USER_DATA_BYTE_00	0x00	0	USER_DATA_BYTE_00								
D1h	USER_DATA_BYTE_01	0x00	0	USER_DATA_BYTE_01								
D2h	PIN_CONFIG_00	0x3C	0	x	PGOOD_PIN_CONFIG				ENABLE_PIN_CONFIG			
D3h	PIN_CONFIG_01	0x00	0	x	x	x	x	x	x	x	SSPG_PIN_CONFIG	
D4h	SEQUENCE_CONFIG	0x00	0	x	x	x	x	x	x	x	START_PGOOD	
D5h	SEQUENCE_ORDER	0x00	0	x	x	x	x	STOP_ORDER		START_ORDER		
D6h	IOUT_MODE	0b000000X1	0	x	x	x	x	x	x	IOUT_SHARE	CCM	
D7h	FREQUENCY_PHASE	<b>PAGE</b>	<b>Val</b>	0	x							CLK_DIV
		0x00	0x00									
		0x01	0x08									
		0x02	0x04									
		0x03	0x0C									
D8h	VREF_COMMAND	0x14	0	x	VREF_COMMAND							

**Table 8-7. Command Bit-Mapping (continued)**

CODE	NAME	DEFAULT VALUE		BYTE	BITS							
					7 (MSB)	6	5	4	3	2	1	0 (LSB)
D9h	IOUT_MAX	PAGE	Val	0	x	x	x	x	x	x	x	IOUT_MAX
		0x00	0x04									
		0x01	0x04									
		0x02	0x03									
		0x03	0x03									
DAh	USER_RAM_00	0x00		0	x	x	x	x	x	x	x	USER_RAM_00
DBh	SOFT_RESET											
DCh	RESET_DELAY	0x00		0	x	x	x	x	x			RESET_DELAY
DDh	TON_TOFF_DELAY	0x01		0	x	x	TON_DELAY			TOFF_DELAY		
DEh	TON_TRANSITION_RATE	0x02		0	x	x	x	x	x			TON_RAMP_RATE
DFh	VREF_TRANSITION_RATE	0x98		0	VREF_RAMP_ENABLE	x	VREF_RAMP_TIMESTEP			VREF_RAMP_BITSTEP		
F0h	SLOPE_COMPENSATION	0x01		0	x	x	x	x	x	x		SLOPE_COMPENSATION
F1h	ISENSE_GAIN	0x01		0	x	x	x	x	x	x		ISENSE_GAIN
FCh	DEVICE_CODE	0xFX		0	DEVICE_CODE_ID				DEVICE_CODE_REV			
		0x00		1	DEVICE_CODE_ID							

## 8.6.1 PMBus Core Commands

These PMBus core commands are defined in the PMBus Specification. This section describes details that are unique to the TPS65400 implementation.

### 8.6.1.1 (00h) PAGE

The PAGE command provides the ability to configure, control, and monitor multiple outputs on a single TPS65400 using a single PMBus physical address. All subsequent commands that depend on PAGE are applied to the rail selected by the PAGE command.

Rails are numbered starting with one, while pages are numbered starting at 0. [Table 8-8](#) shows the relationship between the PMBus PAGE value and the rail number.

**Table 8-8. PAGE Data Byte Contents**

BITS	NAME	READ / WRITE	DEFAULT VALUE	VALUE	OUTPUT RAIL	PAIRING	CURRENT SHARING RELATIONSHIP
7:0	PAGE	R/W	0xFF	0x00	SW1	SW1-SW2	Master
				0x01	SW2		Slave
				0x02	SW3	SW3-SW4	Master
				0x03	SW4		Slave
				0x04 to 0xFE	Invalid	—	—
				0xFF	All	—	—

On the TPS65400, current share is organized in pairs (PAGE = 0x00, 0x01 and PAGE = 0x02, 0x03). When current sharing mode is detected on a particular pair, the slave PAGE is invalid and the slave's default settings follow that of its master PAGE. The only exception is that the slave switcher PWM will be a fixed 180° phase-shift from its master (see [\(D7h\) FREQUENCY\\_PHASE](#)). Additionally, the ISHARE bit will be asserted (see [\(D6h\) IOUT\\_MODE](#)).

[\(00h\\_ PAGE](#) of the register map describes the PAGE command in more detail.

#### Note

The PAGE parameter is not stored in the default store in data flash.

### 8.6.1.2 (01h) OPERATION

The OPERATION command in conjunction with input from the enable pins ENSW<sub>x</sub> is used to turn on or off (enable or disable) the currently selected switching regulator as determined by the current PAGE. Margins are not supported. Data byte contents are given in [Table 8-9](#).

**Table 8-9. Operation Data Byte Contents**

PAGE SUPPORT	BITS [7:6]	BITS [5:4]	BITS [3:2]	BITS [1:0]	SEQUENCING	OUTPUT ON OR OFF	DELAY
0x00 to 0x03, 0xFF	00	XX	XX	XX	No	Immediate off	None
0x00 to 0x03	01	XX	XX	XX	No	Soft off	t <sub>OFF_DELAY</sub>
0xFF	01	XX	XX	XX	Yes	Soft off	t <sub>OFF_DELAY</sub>
0x00 to 0x03	10	00	XX	XX	No	On with soft-start (default)	t <sub>ON_DELAY</sub>
0xFF	10	00	XX	XX	Yes	On with soft-start (default <sup>(1)</sup> )	t <sub>ON_DELAY</sub>

(1) This is also the default behavior upon reset with active ENABLE selected (see [\(D2h\) PIN\\_CONFIG\\_00](#))

Input from the enable pin overrides the off state of the corresponding output. The pin function configuration command PIN\_CONFIG\_00 can accept or ignore enable pins as well as disable OPERATION sequencing command support (see [\(01h\\_ OPERATION](#)). If the OPERATION state is on, and PIN\_CONFIG\_00 is set to accept enable pins, action from enable pins would result in a delay specified by TON\_TOFF\_DELAY. [Figure 8-27](#) shows how the on/off states are triggered.

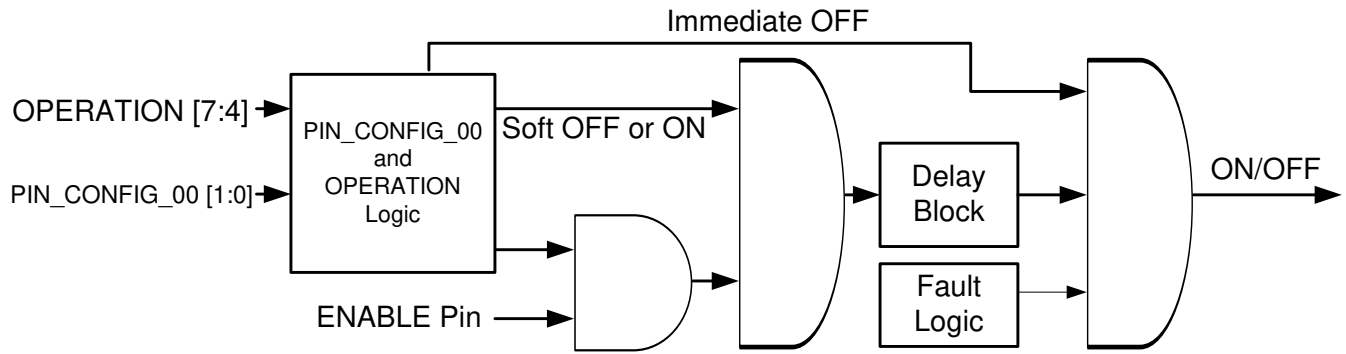

**Figure 8-27. On/Off Configuration (Per Output)**

When a fault occurs, the output state will turn OFF and possibly attempt to turn ON repeatedly for persistent faults. Specific fault response behaviors are described in [Section 8.3.7](#).

**Note**

TI recommends that if OPERATION is to be used exclusively, all outputs should be set to the same order and enable pins should be ignored (see [\(D5h\) SEQUENCE\\_ORDER](#), and [\(D2h\) PIN\\_CONFIG\\_00](#)).

The OPERATION parameter is not stored in the default store in data flash.

**8.6.1.3 (03h) CLEAR\_FAULTS**

The CLEAR\_FAULTS command clears all faults for the selected output. If PAGE 0xFF is selected, all faults for all PAGE outputs are cleared.

**Note**

POWER\_GOOD\_N and OFF indicate the current state of the outputs and cannot be cleared.

**8.6.1.4 (10h) WRITE\_PROTECT**

The WRITE\_PROTECT command disables writes on the PMBus. It has one data byte, described in [Table 8-10](#).

**Table 8-10. WRITE\_PROTECT Command Data Byte Contents**

DATA BYTE VALUE	MEANING
1000 0000	Disable all writes except to the WRITE_PROTECT command
0100 0000 (default)	Disable all writes except to the WRITE_PROTECT, OPERATION, and PAGE commands
0010 0000	Disable all writes except to the WRITE_PROTECT, OPERATION, PAGE, and VREF_COMMAND commands
0000 0000	Enable writes to all commands

If an invalid command is received, a communications fault is set. WRITE\_PROTECT does not protect against CLEAR\_FAULTS. The user is able to CLEAR\_FAULTS anytime regardless of the WRITE\_PROTECT state.

This command has no PAGE support.

**Note**

The WRITE\_PROTECT parameter is not stored in the default store in data flash.

### 8.6.1.5 (11h) STORE\_DEFAULT\_ALL

The STORE\_DEFAULT\_ALL command saves the PMBus parameters from operating memory into the default store in data flash (EEPROM). The TPS65400 uses the most recently written set of default store values at startup. The maximum time it takes for the data flash to be written is 70 ms.

This command has no PAGE support.

#### Note

The OPERATION, PAGE, and WRITE\_PROTECT parameters are not stored in the default store in data flash.

#### CAUTION

When STORE\_DEFAULT\_ALL is issued, operating memory should not be written to during the save.

### 8.6.1.6 (19h) CAPABILITY

The CAPABILITY command is a read-only command.

This command has no PAGE support.

**Table 8-11. CAPABILITY COMMAND Data Byte Contents**

BIT	READ / WRITE	DEFAULT VALUE	MEANING
7	R	1	Packet error checking is supported
6:5	R	01	Maximum supported bus speed is 400 kHz
4	R	0	Device does not have a $\overline{\text{SMBALERT}}$ pin and does not support the SMBus alert response protocol
3:0	R	0000	Reserved

### 8.6.1.7 (78h) STATUS\_BYTE

The STATUS\_BYTE command is a read-only command. Write mask is not supported. The bits are listed in [Table 8-12](#).

**Table 8-12. STATUS\_BYTE Data Byte Contents**

PAGE SUPPORT	BIT	NAME	READ / WRITE	DEFAULT VALUE	MEANING
—	7	Not supported	R	0	—
Yes	6	OFF	R	—	Output is off
Yes	5	VOUT_OV	R	—	Output overvoltage fault
Yes	4	IOUT_OC	R	—	Output overcurrent fault
No	2	TEMPERATURE	R	—	Overtemperature fault
—	3	Not supported	R	0	—
No	1	CML	R	—	Invalid command code, data, or packet
Yes	0	NONE OF THE ABOVE	R	—	A fault or warning not listed in bits [7:1] has occurred

Overtemperature fault and CML is independent of PAGE. When there is PAGE support, the meaning of the bits applies only for the selected output PAGE. For PAGE = 0xFF, STATUS\_BYTE is a logical OR of all PAGE = 0x00 to 0x03 STATUS\_BYTE values.

An exception to NONE OF THE ABOVE is that the MFR bit in STATUS\_WORD is ignored due to no PAGE support.

PAGE support is for outputs 0x00 to 0x03, 0x0FF.

### 8.6.1.8 (79h) STATUS\_WORD

The STATUS\_WORD command is a read-only command. Write mask is not supported. Only the parameters in [Table 8-13](#) are supported.

**Table 8-13. STATUS\_WORD Data Word Contents (Upper Byte)**

PAGE SUPPORT	BIT	NAME	READ / WRITE	DEFAULT VALUE	MEANING
Yes	7	VOUT	R	—	Output voltage fault set if any bit in STATUS_VOUT is asserted (for the same page)
—	6	Not supported	R	0	—
—	5	Not supported	R	0	—
No	4	MFR	R	—	Set if any bit in STATUS_MFR_SPECIFIC is asserted
Yes	3	POWER_GOOD_N	R	—	Output voltage is within PGOOD range, negated
—	2	Not supported	R	0	—
—	1	Not supported	R	0	—
—	0	Not supported	R	0	—

The lower byte of STATUS\_WORD is STATUS\_BYTE.

The MFR bit is independent of PAGE. When there is PAGE support, the meaning of the bits applies only for the selected output PAGE. For PAGE = 0xFF, STATUS\_WORD is a logical OR of all PAGE = 0x00 to 0x03 STATUS\_WORD values.

PAGE support is for outputs 0x00 to 0x03, 0x0FF.

### 8.6.1.9 (7Ah) STATUS\_VOUT

The STATUS\_VOUT command is a read-only command. Write mask is not supported. Only the parameters in [Table 8-14](#) are supported.

**Table 8-14. STATUS\_VOUT Data Byte Contents**

BIT	NAME	READ / WRITE	DEFAULT VALUE	MEANING
7	VOUT_OV	R	—	VOUT overvoltage fault
6	Not supported	R	0	—
5	Not supported	R	0	—
4	VOUT_UV	R	—	VOUT undervoltage fault
3	Not supported	R	0	—
2	Not supported	R	0	—
1	Not supported	R	0	—
0	Not supported	R	0	—

STATUS\_VOUT shows the voltage output status for the PAGE selected output. For PAGE = 0xFF, STATUS\_VOUT is a logical OR of all PAGE = 0x00-0x03 STATUS\_VOUT values. VOUT\_OV in STATUS\_VOUT is identical to VOUT\_OV in STATUS\_BYTE for the same PAGE.

PAGE support is for outputs 0x00 to 0x03, 0x0FF.

### 8.6.1.10 (80h) STATUS\_MFR\_SPECIFIC

The STATUS\_MFR\_SPECIFIC command is a read-only command. Write mask is not supported. Only the parameters in [Table 8-15](#) are supported.

**Table 8-15. STATUS\_MFR\_SPECIFIC Data Byte Contents**

BIT	NAME	READ / WRITE	DEFAULT VALUE	MEANING
7	Not supported	R	0	—
6	Not supported	R	0	—
5	Not supported	R	0	—
4	Not supported	R	0	—
3	POWER_GOOD4_N	R	—	SW4 output voltage is within PGOOD range, negated
2	POWER_GOOD3_N	R	—	SW3 output voltage is within PGOOD range, negated
1	POWER_GOOD2_N	R	—	SW2 output voltage is within PGOOD range, negated
0	POWER_GOOD1_N	R	—	SW1 output voltage is within PGOOD range, negated

STATUS\_MFR\_SPECIFIC reports the individual output negated PGOODs. These bit values also can be retrieved from POWER\_GOOD\_N if an individual output is selected through PAGE.

This command has no PAGE support.

### 8.6.1.11 (98h) PMBUS\_REVISION

The PMBUS\_REVISION command is a read-only command.

**Table 8-16. PMBUS\_REVISION Data Byte Contents**

BITS	NAME	READ / WRITE	DEFAULT VALUE	MEANING
7:4	Part I revision	R	0010	Supports version 1.2
3:0	Part II revision	R	0010	Supports version 1.2

This command has no PAGE support.

### 8.6.1.12 (ADh) IC\_DEVICE\_ID

The IC\_DEVICE\_ID command is a read-only block command and returns the ASCII characters of the part number TPS65400.

**Table 8-17. IC\_DEVICE\_ID Data Block Contents**

BYTE	NAME	READ / WRITE	DEFAULT VALUE	ASCII VALUE
7	IC_DEVICE_ID	R	0x30	0
6			0x33	3
5			0x34	4
4			0x36	6
3			0x32	2
2			0x4D	M
1			0x4C	L
0	Length byte	R	0x07	—

This command has no PAGE support.

### 8.6.1.13 (AEh) IC\_DEVICE\_REV

The IC\_DEVICE\_REV command is a read-only block command and returns the 2-byte device code of the part. The device code is identical to the 2-byte DEVICE\_CODE. Refer to DEVICE\_CODE for details (see [\(FCh\) DEVICE\\_CODE](#)).

**Table 8-18. IC\_DEVICE\_REV Data Block Contents**

BYTE	NAME	READ / WRITE	DEFAULT VALUE
2:1	DEVICE_CODE	R	See DEVICE_CODE
0	Length byte	R	0x02

This command has no PAGE support.

## 8.6.2 Manufacturer-Specific Commands

### 8.6.2.1 (D0h) USER\_DATA\_BYTE\_00

The USER\_DATA\_BYTE\_00 command contains 8 bits for reading and writing user-defined data. Upon issuing STORE\_DEFAULT\_ALL, contents of this command are saved to the default store in data flash.

**Table 8-19. USER\_DATA\_BYTE\_00 Data Byte Contents**

BITS	NAME	READ / WRITE	DEFAULT VALUE
7:0	USER_DATA_BYTE_00	R/W	0x00

This command has no PAGE support.

### 8.6.2.2 (D1h) USER\_DATA\_BYTE\_01

The USER\_DATA\_BYTE\_01 command contains 7 bits, USER\_DATA\_BITS\_01, for reading and writing user-defined data. Upon issuing STORE\_DEFAULT\_ALL, contents of this command are saved to the default store in data flash.

The most significant bit, STORED, is a read-only bit that indicates whether the user has written to the default store through STORE\_DEFAULT\_ALL. This indicator bit cannot be cleared.

**Table 8-20. USER\_DATA\_BYTE\_01 Data Byte Contents**

BITS	NAME	READ / WRITE	DEFAULT VALUE
7	STORED	R	0
6:0	USER_DATA_BYTE_01	R/W	0000000

This command has no PAGE support.

### 8.6.2.3 (D2h) PIN\_CONFIG\_00

The PIN\_CONFIG\_00 command selects pin function and behavior for enable pins ENSWx and the global PGOOD pin.

ENABLE\_PIN\_CONFIG selects between active ENABLE, inactive ENABLE, or single ENABLE behavior for ENSWx pins.

- When active ENABLE is selected, each pin in conjunction with OPERATION controls its respective switcher on/off. For details, see [\(01h\) OPERATION](#) and [\(DDh\) TON\\_TOFF\\_DELAY](#).
- When inactive ENABLE is selected, the state of all ENSWx pins is ignored.
- When single ENABLE is selected, ENSW1 pin acts as a sequence start and sequence stop pin, with all other ENSWx pins ignored. This allows the device to emulate classic sequencing behavior. A start sequence begins when ENSW1 is asserted, and a stop sequence begins when ENSW1 is deasserted. If ENSW1 were to de-assert before a start sequence were complete, a stop-sequence would begin immediately.

PGOOD\_PIN\_CONFIG sets the function of the global PGOOD pin.

- By default, the global PGOOD pin is configured to output a logical AND of each individual power supply's PGOOD. If all supplies were to turn off, the global PGOOD pin would be de-asserted.
- The global PGOOD pin can be selected to output the status of any individual power supply's PGOOD, or any OR/AND combination thereof. If an individual supply's PGOOD#\_MASK bit is masked, its PGOOD status would be masked from the global PGOOD pin. If all PGOOD#\_MASK pins were masked, the output of the global PGOOD pin would be at logic zero regardless of the PGOOD\_LOGIC selected.

- PGOOD#\_MASK only applies to the output pin logic and does not affect STATUS\_WORD or sequencing.
- In current sharing mode, slave channel PGOOD must be masked, otherwise, global PGOOD would be asserted to low.

**Table 8-21. PIN\_CONFIG\_00 Data Byte Contents**

BITS	NAME	READ / WRITE	DEFAULT VALUE	BINARY VALUE	MEANING	PINS AFFECTED
7	—	R	0	—	—	—
6	PGOOD_PIN_CONFIG: PGOOD_LOGIC	R/W	0	0	AND of all unmasked PGOODs	Global PGOOD pin
				1	OR of all unmasked PGOODs	
5	PGOOD_PIN_CONFIG: PGOOD4_MASK	R/W	1	0	PGOOD4 is masked	
				1	PGOOD4 is unmasked	
4	PGOOD_PIN_CONFIG: PGOOD3_MASK	R/W	1	0	PGOOD3 is masked	
				1	PGOOD3 is unmasked	
3	PGOOD_PIN_CONFIG: PGOOD2_MASK	R/W	1	0	PGOOD2 is masked	
				1	PGOOD2 is unmasked	
2	PGOOD_PIN_CONFIG: PGOOD1_MASK	R/W	1	0	PGOOD1 is masked	
				1	PGOOD1 is unmasked	
1:0	ENABLE_PIN_CONFIG	R/W	00	00	Active ENABLE Enable pins ENSWx control each switcher independently	ENSW# pins
				01	Inactive ENABLE All enable pins ENSWx are ignored	
				1X	Single ENABLE ENSW1 starts and stops sequencing. All other enable pins are ignored.	

Table 8-22 shows example configurations for PGOOD\_PIN\_CONFIG.

**Table 8-22. PGOOD\_PIN\_CONFIG Example Configurations**

PGOOD_PIN_CONFIG BINARY VALUE	GLOBAL PGOOD PIN	COMMENTS
01111 (default)	PGOOD1 and PGOOD2 and PGOOD3 and PGOOD4	
11111	PGOOD1 or PGOOD2 or PGOOD3 or PGOOD4	
00101	PGOOD1 and PGOOD3	Buck1,2 current sharing mode, Buck3,4 current sharing mode
01101	PGOOD1 and PGOOD3 and PGOOD4	Buck1,2 current sharing mode
00111	PGOOD1 and PGOOD2 and PGOOD3	Buck3,4 current sharing mode
X0001	PGOOD1	Only monitor Buck1's status
X0010	PGOOD2	Only monitor Buck2's status
X0100	PGOOD3	Only monitor Buck3's status
X1000	PGOOD4	Only monitor Buck4's status

This command has no PAGE support.

**CAUTION**

Changing PIN\_CONFIG\_00 during normal operation has no effect. The configuration can only be modified by storing into EEPROM and then reloading the configuration upon reset.

### 8.6.2.4 (D3h) PIN\_CONFIG\_01

PIN\_CONFIG\_01 command selects pin function and behavior for the selected output's SSx/  $\overline{\text{PG}}$  pin.

SSPG\_PIN\_CONFIG sets the selected power supply's SSx/  $\overline{\text{PG}}$  pin to a soft-start time input pin or a power good output pin.

- When selected as soft-start time input pin SSx, the internal soft-start ramp rate TON\_TRANSITION\_RATE is ignored. A 5- $\mu\text{A}$  current source will be connected internally and an external capacitor can be used to set the soft-start delay.
- When selected as a power good output pin  $\overline{\text{PG}}$  (  $\overline{\text{PGOOD}}$  ), the pin outputs the status of the selected power supply's power good.

**Table 8-23. PIN\_CONFIG\_01 Data Byte Contents**

BITS	NAME	READ / WRITE	DEFAULT VALUE	BINARY VALUE	MEANING	PINS AFFECTED
7:1	—	R	0000000	—	—	—
0	SSPG_PIN_CONFIG	R/W	0	0	SSx pin	SSx/ $\overline{\text{PG}}$ pin
				1	$\overline{\text{PG}}$ pin	

PAGE support is for outputs 0x00 through 0x03.

#### CAUTION

Changing PIN\_CONFIG\_01 during normal operation will have no effect. The configuration can only be modified by storing into EEPROM and then reloading the configuration upon reset.

### 8.6.2.5 (D4h) SEQUENCE\_CONFIG

The SEQUENCE\_CONFIG command determines sequencing behavior.

START\_PGOOD determines whether the next output in sequence looks at the previous output's PGOOD before turning on. For turning on, the previous output's PGOOD must be good. For the first in sequence, there is no PGOOD reference so START\_PGOOD for those particular switchers are ignored. START\_PGOOD applies to all switchers.

**Table 8-24. SEQUENCE\_CONFIG Data Byte Contents**

BITS	NAME	READ / WRITE	DEFAULT VALUE	BINARY VALUE	MEANING
7:1	—	R	0000000	—	—
0	START_PGOOD	R/W	0	0	PGOOD is checked
				1	PGOOD is ignored

This command has no PAGE support.

#### CAUTION

TI does not recommend changing SEQUENCE\_CONFIG during start sequencing or stop sequencing.

### 8.6.2.6 (D5h) SEQUENCE\_ORDER

The SEQUENCE\_ORDER command determines the order in which each output starts and stops. If two or more supplies are assigned the same sequence number, they start/stop at the same time. If sequencing is not used, all sequence bits should be set to the same value. For PGOOD sequencing options, see [\(D4h\) SEQUENCE\\_CONFIG](#).

**Table 8-25. SEQUENCE\_ORDER Data Byte Contents**

BITS	NAME	READ / WRITE	DEFAULT VALUE	BINARY VALUE	VALUE	MEANING
7:4	—	R	0000	—	—	—
3:2	STOP_ORDER	R/W	00	00	1 (first to stop)	Stop sequence order number
				01	2	
				10	3	
				11	4 (last to stop)	
1:0	START_ORDER	R/W	00	00	1 (first to start)	Start sequence order number
				01	2	
				10	3	
				11	4 (last to start)	

**CAUTION**

TI does not recommend changing SEQUENCE\_ORDER during start sequencing or stop sequencing.

PAGE support is for outputs 0x00 to 0x03.

**8.6.2.7 (D6h) IOUT\_MODE**

The IOUT\_MODE command configures the selected output to be:

- Operating in CCM
- Operating in Mixed CCM/DCM

There is a read-only bit, IOUT\_SHARE, that indicates that the current selected output:

- Shares its current
- Does not share its current

On the TPS65400, current share is organized in pairs (PAGE = 0x00, 0x01 and PAGE = 0x02, 0x03). When current sharing mode is detected on a particular pair, the slave PAGE is invalid and the slave's default settings follow that of its master PAGE. The only exception is that the slave switcher PWM is a fixed 180° phase-shift from its master (see [\(D7h\) FREQUENCY\\_PHASE](#)).

**Table 8-26. IOUT\_MODE Data Byte Contents**

BITS	NAME	READ / WRITE	DEFAULT VALUE	BINARY VALUE	MEANING
7:2	—	R	000000	—	—
1	IOUT_SHARE	R	—	0	Current is not shared
				1 <sup>(1)</sup>	Current is shared <sup>(1)</sup>
0	CCM	R/W	1	0	Mixed CCM/DCM
				1	CCM

(1) This bit is only observable from the master PAGEs (see [\(00h\) PAGE](#)).

PAGE support is for outputs 0x00 through 0x03.

**CAUTION**

Changing IOUT\_MODE during normal operation has no effect. The configuration can only be modified by storing into EEPROM and then reloading the configuration upon reset.

**8.6.2.8 (D7h) FREQUENCY\_PHASE**

The FREQUENCY\_PHASE command sets the output switching frequency and phase of the selected output. The switching frequency is a quotient from the division of the master clock, F<sub>OSC</sub>, by the selected divisor CLK\_DIV.

PHASE\_DELAY determines the phase shift as a multiple of the internal PLL period, which is scaled at 4× less than the master clock period 1 / F<sub>OSC</sub>.

**Table 8-27. FREQUENCY\_PHASE Data Byte Contents**

BITS	NAME	READ / WRITE	DEFAULT VALUE	BINARY VALUE	VALUE	MEANING
7	—	R	0	—	—	—
6:2	PHASE_DELAY	R/W	See <a href="#">Table 8-28</a>	00000	0	Switching delay time (phase)
				00001	1 / (4 × FOSC)	
				..	..	
				11110	30 / (4 × FOSC)	
				11111	31 / (4 × FOSC)	
1:0	CLK_DIV	R/W	00	00	FOSC / 1	Switching frequency
				01	FOSC / 2	
				10	FOSC / 4	
				11	FOSC / 8	

**Table 8-28. PHASE\_DELAY Default Data Bit Values**

PAGE	PHASE_DELAY BINARY VALUE	PHASE SHIFT (°)
0x00	00000	0
0x01	00010	180
0x02	00001	90
0x03	00011	270

The phase shift in degrees is calculated by [Equation 5](#).

$$\text{Phase shift} = \frac{\text{PHASE\_DELAY}}{2^{\text{CLK\_DIV}}} \text{ (degrees)} \tag{5}$$

When current sharing mode is detected on a particular pair, the slave PAGE is invalid and the slave's default settings follow that of its master PAGE. The only exception is that the slave switcher PWM is a fixed 180° phase-shift from its master. Additionally, the ISHARE bit is asserted (see [\(D6h\) IOUT\\_MODE](#)).

PAGE support is for outputs 0x00 through 0x03.

**CAUTION**

Changing the FREQUENCY\_PHASE during normal operation has no effect. The configuration can only be modified by storing into EEPROM and then reloading the configuration upon reset.

### 8.6.2.9 (D8h) VREF\_COMMAND

The VREF\_COMMAND command sets the voltage reference (VREF) for the selected output. Values range from 0.6 to 1.87 V with a bit resolution of 10 mV per LSB.

**Table 8-29. VREF\_COMMAND Data Byte Contents**

BITS	NAME	READ / WRITE	DEFAULT VALUE	BINARY VALUE	VALUE	MEANING
7	—	R	0	—	—	—
6:0	VREF_COMMAND	R/W	0010100	0000000	0.60 V	Reference voltage
				0000001	0.61 V	
				...	...	
				0010100	0.8 V	
				...	...	
				1111110	1.86 V	
1111111	1.87 V					

The voltage reference can be changed while one or more voltage outputs are enabled. To reduce the effect of large transient steps, digital slew rate limiting is implemented. The larger the change in the voltage reference, the greater the delay that is incurred as the voltage steps toward the new reference. For details, see [\(DFh\) VREF\\_TRANSITION\\_RATE](#).

Faults are blanked during transition. A 100-s fault blanking time results after a transition completes.

PAGE support is for outputs 0x00 through 0x03.

### 8.6.2.10 (D9h) IOUT\_MAX

The IOUT\_MAX command sets the current limit for the selected output.

**Table 8-30. IOUT\_MAX Data Byte Contents, PAGE = 0x00, 0x01**

BITS	NAME	READ / WRITE	DEFAULT VALUE	BINARY VALUE	VALUE	MEANING
7:3	—	R	00000	—	—	—
2:0	IOUT_MAX	R/W	100	000	2 A	Current limit
				001	3 A	
				010	4 A	
				011	5 A	
				1XX	6 A	

**Table 8-31. IOUT\_MAX Data Byte Contents, PAGE = 0x02, 0x03**

BITS	NAME	READ / WRITE	DEFAULT VALUE	BINARY VALUE	VALUE	MEANING
7:2	—	R	000000	—	—	—
1:0	IOUT_MAX	R/W	11	00	0.5 A	Current limit
				01	1 A	
				10	2 A	
				11	3 A	

The limit set by the IOUT\_MAX byte sets both the high-side and low-side current limit.

PAGE support is for outputs 0x00 through 0x03.

### 8.6.2.11 (DAh) USER\_RAM\_00

The USER\_RAM\_00 command is a reset notification status. Upon any RESET condition, the device clears this value to 0x00. This value can only be set to 0x01 by the PMBus master.

**Table 8-32. USER\_RAM\_00 Data Byte Contents**

BITS	NAME	READ / WRITE	DEFAULT VALUE
7:1	—	R	0000000
0	USER_RAM_00	R/W	0

This command has no PAGE support.

### 8.6.2.12 (DBh) SOFT\_RESET

The SOFT\_RESET command triggers a software reset of the device. It is equivalent to sending an assert-deasserting pulse to the RST\_N pin. Consequently, all switchers turn off and all faults are cleared.

This command has no PAGE support.

### 8.6.2.13 (DCh) RESET\_DELAY

The RESET\_DELAY command sets the delay time before any switcher can begin its soft-start after CE is asserted. Thus, if the turn-on sequence or an individual switcher is enabled before this delay is over, no action occurs until the delay is completed. After this delay period is passed, enabling the turn-on sequence of an individual switcher would have an immediate effect subject to the  $t_{ON\_DELAY}$  and soft-start time.

**Table 8-33. RESET\_DELAY Data Byte Contents<sup>(1)</sup>**

BITS	NAME	READ / WRITE	DEFAULT VALUE	BINARY VALUE	VALUE	MEANING
7:3	—	R	00000	—	—	—
2:0	RESET_DELAY	R/W	000	000	1 ms <sup>(2)</sup>	Reset delay time
				001	50 ms	
				010	100 ms	
				011	250 ms	
				100	500 ms	
				101	1000 ms	
				110	1500 ms	
				111	2000 ms	

- (1) All the delay times are subject to the delay between the rising edge of CE and the stabilizing delay time of the VDDD supply, which can be up to 1.1 ms, depending on the bypass capacitor sizing for these rails. The RESET\_DELAY in the table is in addition to this power-up delay and has an accuracy of  $\pm 62.5 \mu\text{s}$ .
- (2) When setting the RESET\_DELAY to 1 ms, TI recommends that the  $t_{ON\_DELAY}$  for the outputs starting up first be greater than 5 ms. Because, the COMP pin precharge starts at the same time as the RESET\_DELAY. If RESET\_DELAY is 1 ms, and  $t_{ON\_DELAY}$  is 0 ms, then the COMP pin precharge may not stabilize before the switcher soft-start begins. The time needed to stabilize the COMP pin precharge depends on the RC compensation values connected to the COMP pin.

This command has no PAGE support.

### 8.6.2.14 (DDh) TON\_TOFF\_DELAY

The TON\_TOFF\_DELAY command sets the delay times after receiving an on or off command for the selected output to begin turning on or off.

TON\_DELAY of this command are lexically equivalent to TON\_DELAY. If TON\_DELAY is set to 0 ms, the device would begin turning on immediately. If TOFF\_DELAY is set to 0 ms, the device would begin turning off immediately.

**Table 8-34. TON\_TOFF\_DELAY Data Byte Contents**

BITS	NAME	READ / WRITE	DEFAULT VALUE	BINARY VALUE	VALUE	MEANING
7:6	—	R	00	—	—	—
5:3	TON_DELAY	R/W	010	000	0 ms	Delay time before starting
				001	1 ms	
				010	5 ms	
				011	25 ms	
				100	100 ms	
				101	500 ms	
				110	1000 ms	
				111	2000 ms	
2:0	TOFF_DELAY	R/W	000	000	0 ms	Delay time before stopping
				001	1 ms	
				010	5 ms	
				011	25 ms	
				100	100 ms	
				101	500 ms	
				110	1000 ms	
				111	2000 ms	

These delays are always in effect including when the outputs are internally or externally sequenced, or arbitrarily turned on or off. The only exceptions are:

- The device receives an immediate OFF from the OPERATION command.
- The device turns its output off internally (such as in a fault condition).

PAGE support is for outputs 0x00 through 0x03.

### 8.6.2.15 (DEh) TON\_TRANSITION\_RATE

The TON\_TRANSITION\_RATE command sets the soft-start ramp rate for the selected output. This command is ignored by default because soft-start is set externally through the SSx/ PG pin. Only when the SSx/ PG pin is configured as PG through PIN\_CONFIG\_01 will TON\_TRANSITION\_RATE determine the soft-start rate.

The soft-start ramp rate refers to the rate at which the reference voltage is increased. The time to complete the soft-start can be calculated from the target reference voltage as [Equation 6](#).

$$t_{ss} = \frac{V_{ref}}{\text{Soft start ramp rate}} \quad (6)$$

For example, if VREF is set to 0.6 V and the default soft-start ramp rate of 0.5 V/ms is selected, then the soft-start time would be 1.2 ms. If VREF is set to 1 V and the soft-start ramp rate of 0.25 V/ms is selected, then the soft-start time would be 4 ms.

**Table 8-35. TON\_TRANSITION\_RATE Data Byte Contents**

BITS	NAME	READ / WRITE	DEFAULT VALUE	BINARY VALUE	VALUE	MEANING
7:2	—	R	000000	—	—	—
1:0	TON_RAMP_RATE	R/W	10	00	2 V/ms	Soft-start ramping rate
				01	1 V/ms	
				10	0.5 V/ms	
				11	0.25 V/ms	

PAGE support is for outputs 0x00 through 0x03.

#### 8.6.2.16 (DFh) VREF\_TRANSITION\_RATE

The VREF\_TRANSITION\_RATE command determines the stepping rate and stepping size when dynamically switching the reference voltage VREF of the selected output.

**Table 8-36. VREF\_TRANSITION\_RATE Data Byte Contents**

BITS	NAME	READ / WRITE	DEFAULT VALUE	BINARY VALUE	VALUE	MEANING
7	VREF_RAMP_ENABLE	R/W	1	0	—	Ramping disabled
				1	—	Ramping enabled
6	—	R	0	—	—	—
5:3	VREF_RAMP_TIMESTEP	R/W	011	000	1 $\mu$ s	Delay time per ramping step
				001	2 $\mu$ s	
				010	3 $\mu$ s	
				011	4 $\mu$ s	
				100	6 $\mu$ s	
				101	8 $\mu$ s	
				110	12 $\mu$ s	
				111	16 $\mu$ s	
2:0	VREF_RAMP_BITSTEP	R/W	000	See <a href="#">Table 8-37</a>	See <a href="#">Table 8-37</a>	Ramp up and ramp down LSB increments / decrements

**Table 8-37. VREF\_RAMP\_BITSTEP Data Bit Values**

VREF_RAMP_BITSTEP BINARY VALUE	RAMP UP (LSB increments)	RAMP DOWN (LSB decrements)
000 (default)	1	1
001	2	1
010	4	2
011	6	3
100	8	4
101	10	5
110	12	6
111	16	8

VREF\_RAMP\_BITSTEP sets the amount of voltage reference bits to ramp up and ramp down per VREF\_RAMP\_TIMESTEP time. During ramping, if the target step is less than or equal to the VREF\_RAMP\_BITSTEP setting, ramping reduces to a fine voltage step of 1 LSB per VREF\_RAMP\_TIMESTEP time until the target voltage has been reached. For the actual voltage change per LSB, refer to [\(D8h\) VREF\\_COMMAND](#).

PAGE support is for outputs 0x00 through 0x03.

### 8.6.2.17 (F0h) SLOPE\_COMPENSATION

The SLOPE\_COMPENSATION command modifies control loop compensation parameters to compensate for inductor ripple current harmonics from switching.

**Table 8-38. SLOPE\_COMPENSATION Data Byte Contents**

BITS	NAME	READ / WRITE	DEFAULT VALUE	BINARY VALUE	VALUE	MEANING
7:2	—	R	000000	—	—	—
1:0	SLOPE_COMPENSATION	R/W	01	00	45 mV/μs	Slope compensation
				01	70 mV/μs	
				10	100 mV/μs	
				11	145 mV/μs	

The default slope compensation will be adequate for most applications. The equivalent current slope compensation ramp on the inductor can be found by the following formula:

$$\Delta I_L = -G_{mps} \times SL_{comp} \quad (A/S) \quad (7)$$

Where  $G_{mps}$  is the current sense gain of the peak current control to COMP voltage in Amps per Volt and  $SL_{comp}$  is the slope compensation voltage expressed in the table above.

Ideal slope compensation is achieved when:

$$|\Delta I_L| > \frac{V_{out}}{L} \quad (8)$$

PAGE support is for outputs 0x00 through 0x03.

### 8.6.2.18 (F1h) ISENSE\_GAIN

The ISENSE\_GAIN command modifies the current sense  $G_{mps}$  of the feedback loop for the selected output. (F0h) SLOPE\_COMPENSATION describes the equivalent current slope compensation ramp on the inductor.

**Table 8-39. ISENSE\_GAIN Data Byte Contents, PAGE = 0x00, 0x01**

BITS	NAME	READ / WRITE	DEFAULT VALUE	BINARY VALUE	VALUE	MEANING
7:2	—	R	000000	—	—	—
1:0	ISENSE_GAIN	R/W	01	00	20 A/V	Current sense gain
				01	10 A/V	
				10	5 A/V	
				11	2.5 A/V	

**Table 8-40. ISENSE\_GAIN Data Byte Contents, PAGE = 0x02, 0x03**

BITS	NAME	READ / WRITE	DEFAULT VALUE	BINARY VALUE	VALUE	MEANING
7:2	—	R	000000	—	—	—
1:0	ISENSE_GAIN	R/W	01	00	10 A/V	Current sense gain
				01	5 A/V	
				10	2.5 A/V	
				11	1.25 A/V	

PAGE support is for outputs 0x00 through 0x03.

### 8.6.2.19 (FCh) DEVICE\_CODE

The DEVICE\_CODE command returns a 2-byte read-only device code. For the TPS65400, this is 0x00FX, where 'X' is the revision/version number. This command has no PAGE support.

**Table 8-41. DEVICE\_CODE Data Word Contents**

BITS	NAME	READ / WRITE	DEFAULT VALUE
15:4	DEVICE_CODE_ID	R	0x00F
3:0	DEVICE_CODE_REV	R	X

## 9 Application and Implementation

---

### Note

Information in the following applications sections is not part of the TI component specification, and TI does not warrant its accuracy or completeness. TI's customers are responsible for determining suitability of components for their purposes, as well as validating and testing their design implementation to confirm system functionality.

---

### 9.1 Application Information

The TPS65400 PMU is designed to support the trend towards smaller space-constrained systems, which require high-efficiency to limit power dissipation in a closed environment. The TPS65400 is intended to provide a complete highly-efficiency power management solution in a small form factor while providing maximum control through the I<sup>2</sup>C bus and ease of use.

The TPS65400 can support input voltages from 4.5 to 18 V, allowing it to be used in systems powered from a single 5- or 12-V intermediate power bus. High system power conversion efficiency is achieved by providing a single-stage conversion from, for example, the 12-V input voltage to the high-current voltage rails required by the digital circuits.

The two buck regulators SW1 and SW2 can provide an output voltage in the range of 0.6 V to 90%V<sub>in</sub> and up to 4-A peak continuous current.

The two buck regulators SW3 and SW4 can provide an output voltage in the range of 0.6 V to 90%V<sub>in</sub> and up to 2-A peak continuous current. <sup>2 3</sup>

---

<sup>2</sup> ESD using the human body model, which is a 100-pF capacitor discharged through a 1.5-kΩ resistor into each terminal.

<sup>3</sup> Maximum sustainable DC current depends on ambient temperature and IC power dissipation (see [Section 7.4](#))

## 9.2 Typical Applications

### 9.2.1 Internal Operation Typical Application

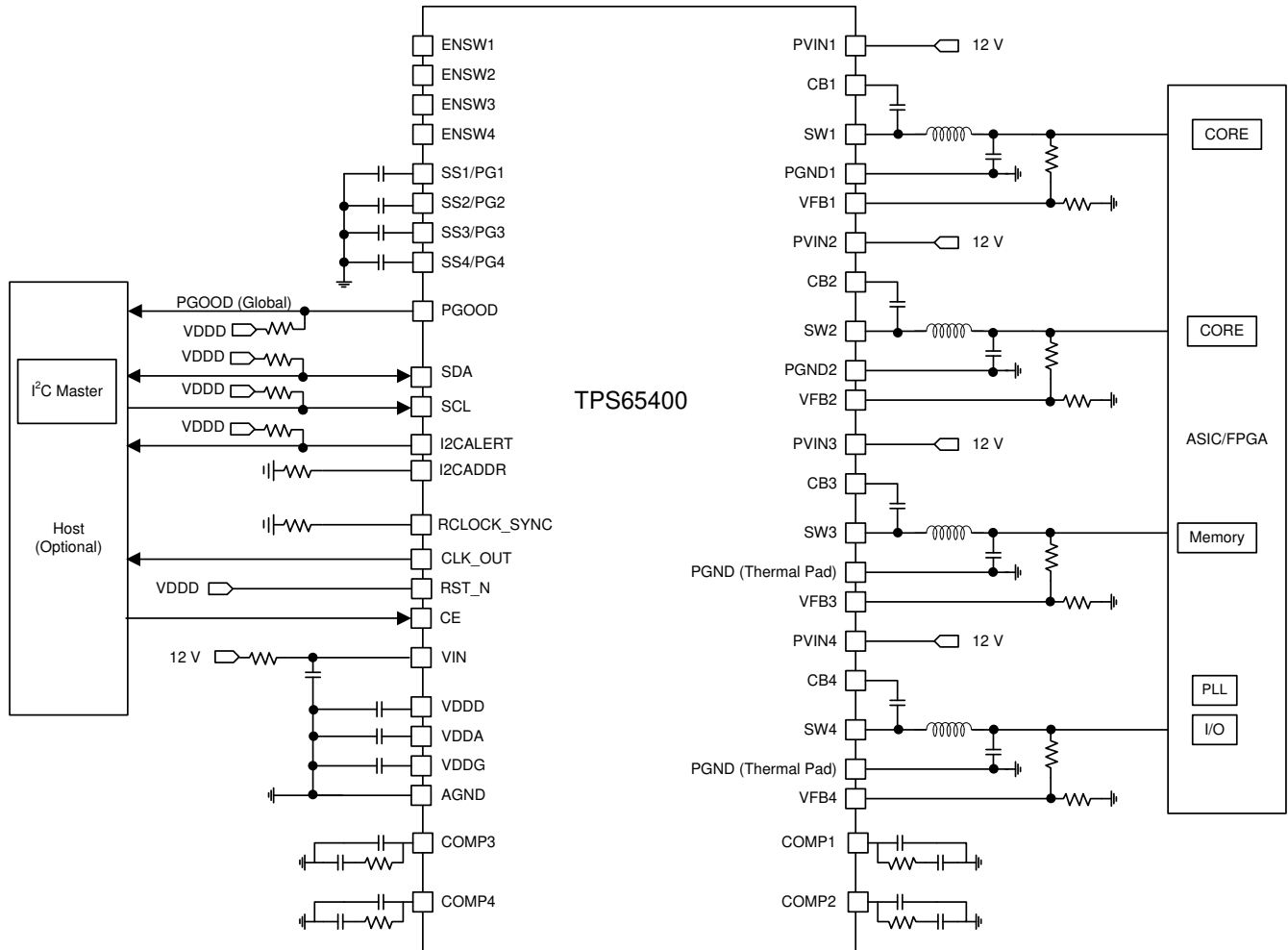

Figure 9-1. Typical Application Schematic

#### 9.2.1.1 Design Requirements

Table 9-1 lists PMBus commands to configure this device.

Table 9-1. PMBus Commands Used for Internal Operation

COMMAND NAME	CODE	NAME	BITS	COMMENT
PAGE	00h	—	7:0	Selects output rail
STORE_DEFAULT_ALL	11h	—	—	Save settings as default
PIN_CONFIG_00	D2h	PGOOD_PIN_CONFIG	6:2	Configure PGOOD pin to mask PGOOD4
		ENABLE_PIN_CONFIG <sup>(1)</sup>	1:0	Active ENABLE (manufacturer default)
PIN_CONFIG_01	D3h	SSPG_PIN_CONFIG	0	Set to $\overline{\text{PG}}$ for internal soft-start
SEQUENCE_CONFIG	D4h	START_PGOOD	0	Disable PGOOD dependence
SEQUENCE_ORDER	D5h	START_ORDER	3:2	Start sequence order
		STOP_ORDER	1:0	Stop sequence order
RESET_DELAY	DCh	RESET_DELAY <sup>(1)</sup>	2:0	Reset delay time
TON_TOFF_DELAY	DDh	TON_DELAY	5:3	Delay time before starting
		TOFF_DELAY	2:0	Delay time before stopping

**Table 9-1. PMBus Commands Used for Internal Operation (continued)**

COMMAND NAME	CODE	NAME	BITS	COMMENT
TON_TRANSITION_RATE	DEh	TON_RAMP_RATE	1:0	Internal soft-start ramping rate

(1) Only necessary if the defaults have been overwritten since device manufacture

To achieve the timing requirements shown in [Table 9-1](#), an example configuration script is shown in [Table 9-2](#).

**Table 9-2. Example Configuration Script for Internal Operation**

COMMAND NAME	CODE	WRITE BYTE	COMMENT
PAGE	00h	0xFF	Selects all
PIN_CONFIG_00	D2h	0x1C	PGOOD pin is a function of PGOOD1 and PGOOD2 and PGOOD3
SEQUENCE_CONFIG	D4h	0x01	Disable PGOOD dependence
RESET_DELAY <sup>(1)</sup>	DCh	0x02	100-ms reset delay
PAGE	00h	0x00	Selects SW1
PIN_CONFIG_01	D3h	0x01	Configure SS1/PG1 pin to PG1 for internal soft-start
SEQUENCE_ORDER	D5h	0x08	First to Start, third to Stop
TON_TOFF_DELAY	DDh	0x04	0-ms turn-on delay 100-ms turn-off delay
TON_TRANSITION_RATE	DEh	TON_RAMP_RATE	Internal soft-start ramping rate
PAGE	00h	0x02	Selects SW3
PIN_CONFIG_01	D3h	0x01	Configure SS3/PG3 pin to PG3 for internal soft-start
SEQUENCE_ORDER	D5h	0x05	Second to start, second to stop
TON_TOFF_DELAY	DDh	0x23	100-ms turn-on delay 25-ms turn-off delay
TON_TRANSITION_RATE	DEh	TON_RAMP_RATE	Internal soft-start ramping rate
PAGE	00h	0x01	Selects SW2
PIN_CONFIG_01	D3h	0x01	Configure SS2/PG2 pin to PG2 for internal soft-start
SEQUENCE_ORDER	D5h	0x02	Third to start, first to stop
TON_TOFF_DELAY	DDh	0x23	100-ms turn-on delay 25-ms turn-off delay
TON_TRANSITION_RATE	DEh	TON_RAMP_RATE	Internal soft-start ramping rate
STORE_DEFAULT_ALL	11h	—	Save settings as default

(1) Only necessary if the defaults have been overwritten after device manufacture.

### 9.2.1.2 Detailed Design Procedure

#### 9.2.1.2.1 Component Selection

##### 9.2.1.2.1.1 Output Inductor Selection

[Equation 9](#) gives the current ripple flowing in the inductor in CCM.

$$\Delta I_L = \frac{V_{out} \times \left(1 - \frac{V_{out}}{V_{in}}\right)}{L \times f_{sw}} \quad (9)$$

where

- $\Delta I_L$  is the current ripple in the inductor.
- $V_{out}$  is the output voltage.
- $V_{in}$  is the input voltage of the converter.
- $L$  is the value of the inductor in henry.
- $f_{sw}$  is the switching frequency of the converter.

Typically, the value of L is chosen to have the ripple current be 0.1× to 0.3× the full-load current. Choose the inductor so that the saturation current is higher than the maximum expected current plus half the current ripple at maximum operating temperature.

#### 9.2.1.2.1.2 Output Capacitor Selection

The output capacitor needs to be properly sized to reduce voltage ripple due to the switching action (ripple voltage) and to reduce output voltage swings during transient load currents. Equation 10 gives the output voltage ripple.

$$\Delta V_{\text{out\_ripple}} = \frac{(V_{\text{in}} - V_{\text{out}}) \times V_{\text{out}}}{8f_{\text{sw}}^2 \times C \times L \times V_{\text{in}}} \quad (10)$$

Equation 11 gives the voltage variation during output current transients.

$$\Delta V_{\text{out\_transient}} = \frac{\Delta I_{\text{out\_transient}}^2 \times L}{C_o \times V_{\text{out}}} \quad (11)$$

#### 9.2.1.2.2 Internal Operation With Some Switchers Disabled

For applications where the internal settings for sequencing and soft-start are sufficient, all used output rails should have their enable terminals ENSWx tied high or floating and all unused output rails should have their enable pins ENSWx tied low for the default active ENABLE setting of ENABLE\_PIN\_CONFIG. This prevents the device from turning on an unused output by software default from an OPERATION ON request. This requirement extends to unpowered switchers; if a pair of switchers is unused, then both ENSWx pins must be tied low.

#### 9.2.1.2.3 Internal Operation With All Switchers Enabled

For applications where all outputs rails will be used, it is sufficient to leave all enable terminals ENSWx disconnected and to set ENABLE\_PIN\_CONFIG to inactive.

#### 9.2.1.2.4 Example Configuration

Figure 9-2 shows an internal sequencing schematic example where only switchers 1 to 3 are used for a set of timing requirements. If the internal configuration and fault handling is sufficient, and provided that the user configures the chip through SDA/SCL before placing it on a target board, then it is not necessary for a supervisory and housekeeping host controller chip like a MCU or DSP to be connected to the TPS65400. In such a case, digital terminals PGOOD, SSx/  $\overline{\text{PG}}$ , SDA/SCL, I2CALERT, and CLK\_OUT can be left unconnected with no pull-ups required, during normal operation. RST\_N can be tied directly to VDDD (no pull-up required). I2CADDR can be tied directly to VDDD after programming. Control line CE can be left unconnected if the chip is constantly powered after VIN is provided.

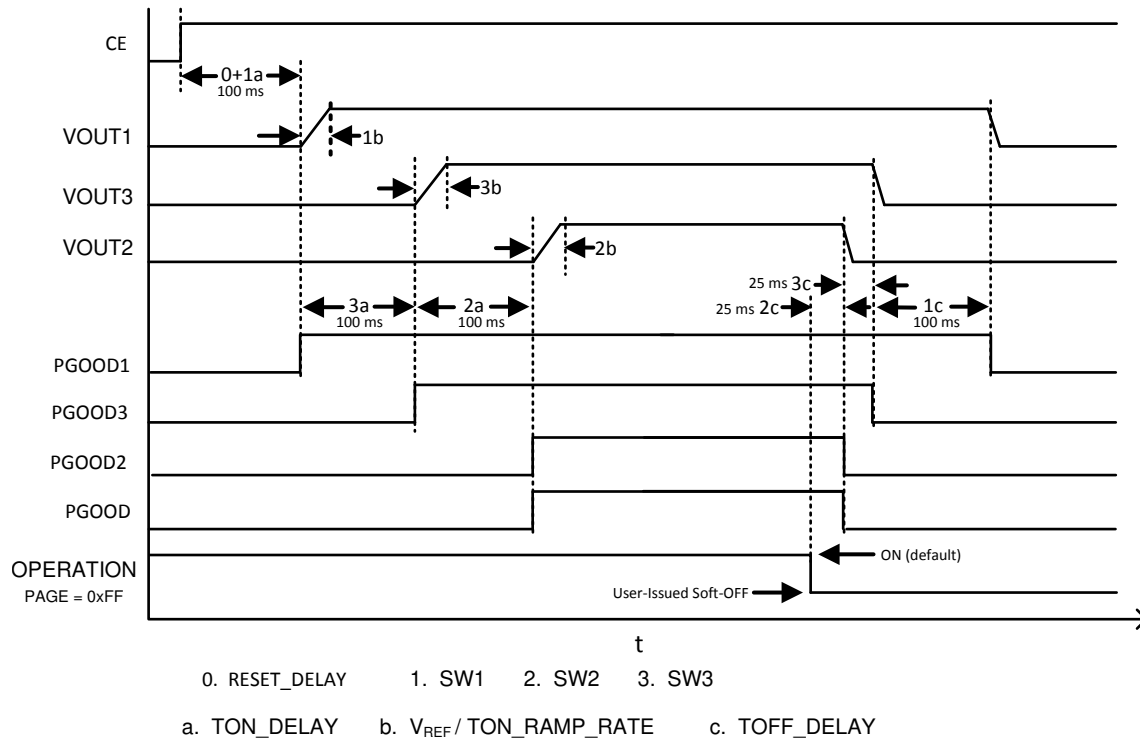

PGOOD dependence disabled, switcher 4 disabled

**Figure 9-2. Example Timing Diagram for Internal Sequencing**

**9.2.1.2.5 Unused Switchers**

If the default setting active ENABLE of ENABLE\_PIN\_CONFIG is selected, ENSWx for unused switchers must always be tied low.

### 9.2.1.3 Application Curves

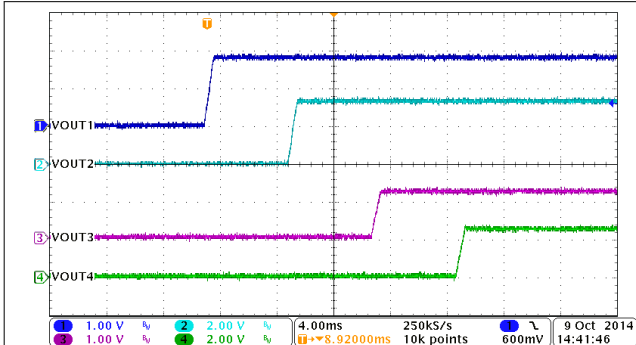

Figure 9-3. Configurable Power-Up Sequence

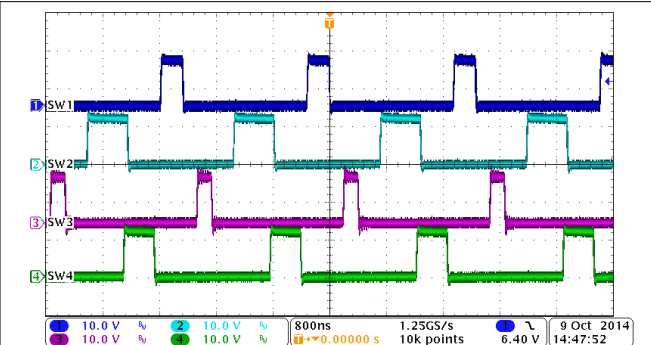

Figure 9-4. Phase Shift Between Channels

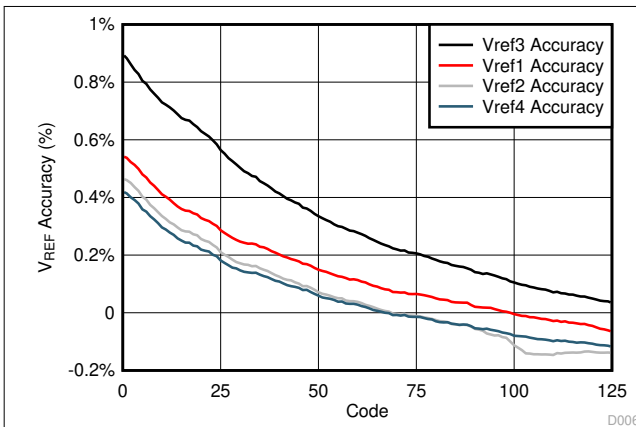

Figure 9-5.  $V_{REF}$  Accuracy vs Code

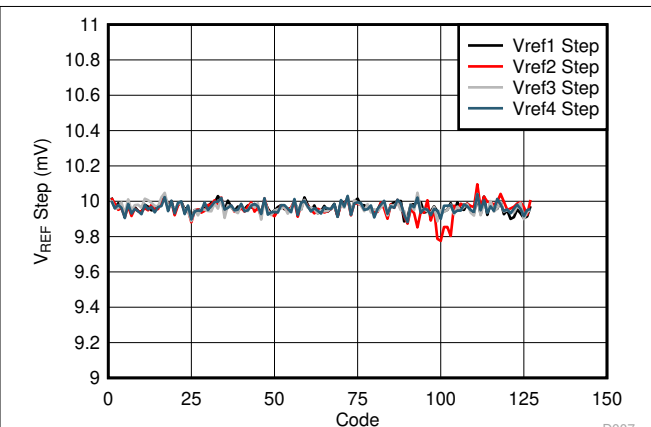

Figure 9-6.  $V_{REF}$  Step Accuracy vs Code

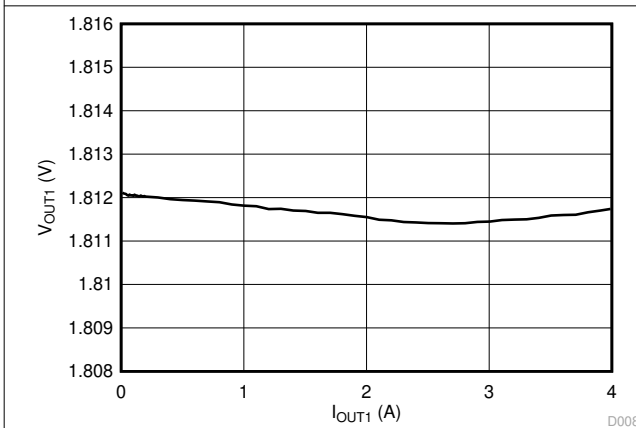

Figure 9-7.  $V_{OUT1}$  Load Regulation

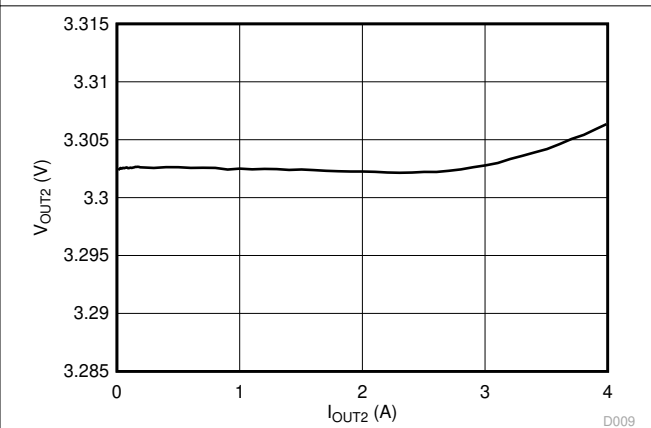
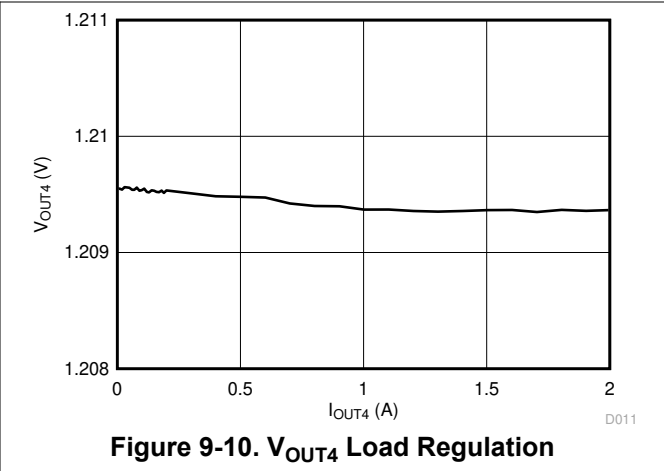
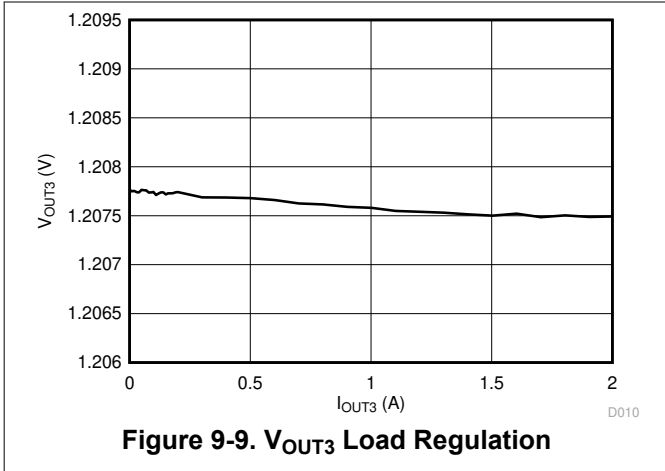
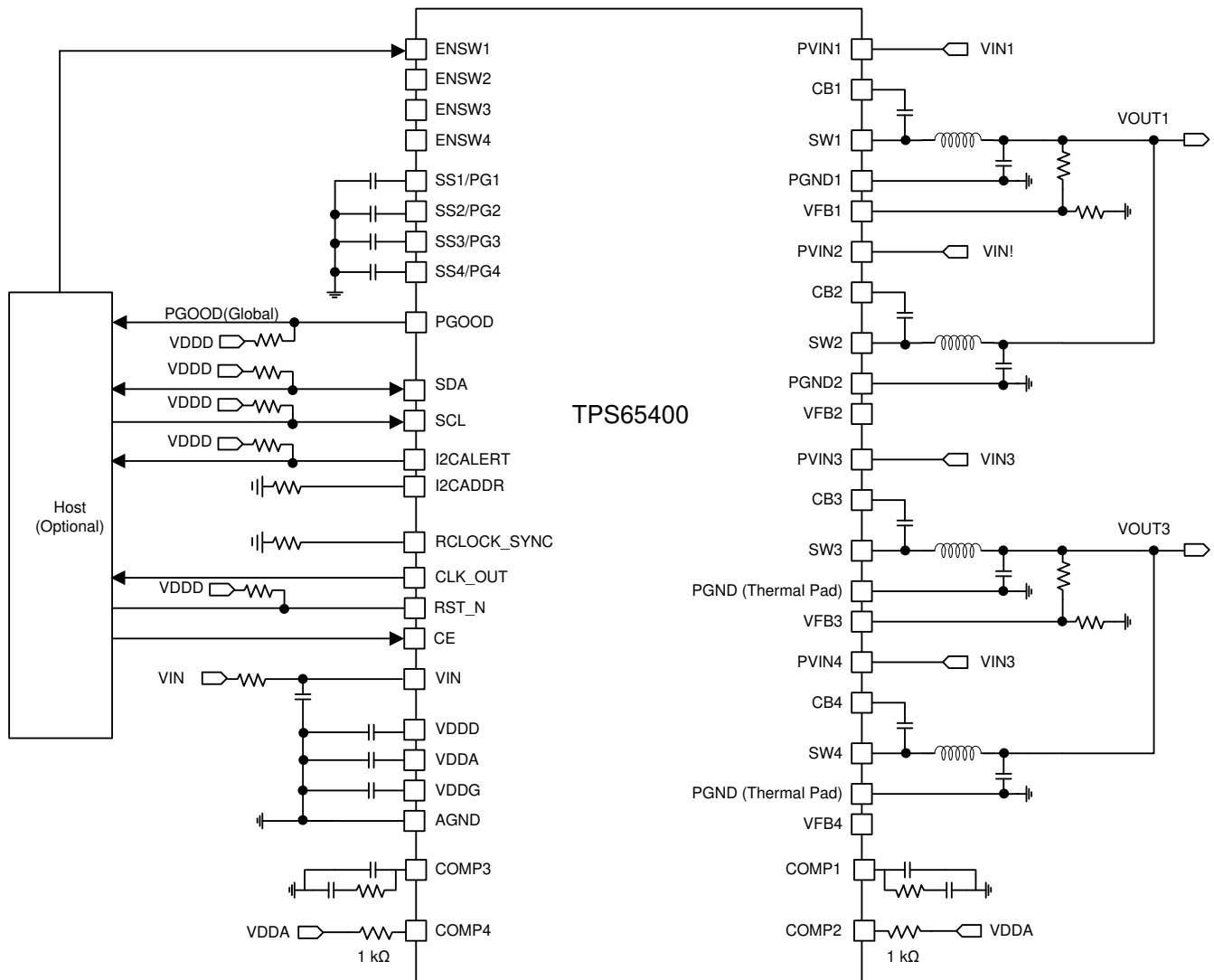

Figure 9-8.  $V_{OUT2}$  Load Regulation



### 9.2.2 Current Sharing Typical Application

An example configuration is shown where both pairs of outputs are current shared. Soft-start time is configured externally with capacitors (this is the default setting) and ENABLE\_PIN\_CONFIG is set to single ENABLE.



Copyright © 2017, Texas Instruments Incorporated

**Figure 9-11. Current Sharing Schematic**

### 9.2.2.1 Design Requirements

Table 9-3 lists PMBus commands to configure this device.

**Table 9-3. PMBus Commands Used for Current Sharing With Single-Pin Enable<sup>(1)</sup>**

COMMAND NAME	CODE	NAME	BITS	COMMENT
PAGE	00h	—	7:0	Selects output rail
STORE_DEFAULT_ALL	11h	—	—	Save settings as default
PIN_CONFIG_00	D2h	PGOOD_PIN_CONFIG <sup>(1)</sup>	6:2	PGOOD pin and of all PGOOD (manufacturer default)
		ENABLE_PIN_CONFIG	1:0	Single ENABLE
PIN_CONFIG_01	D3h	SSPG_PIN_CONFIG <sup>(1)</sup>	0	Set to SSx for external soft-start (manufacturer default)
SEQUENCE_CONFIG	D4h	START_PGOOD <sup>(1)</sup>	0	Enable PGOOD dependence (manufacturer default)
SEQUENCE_ORDER	D5h	START_ORDER	3:2	Start sequence order
		STOP_ORDER	1:0	Stop sequence order
TON_TOFF_DELAY	DDh	TON_DELAY	5:3	Delay time before starting
		TOFF_DELAY	2:0	Delay time before stopping

(1) Only necessary if the defaults have been overwritten since device manufacture.

To achieve the timing requirements shown in Table 9-3, see the example configuration script in Table 9-4.

**Table 9-4. Example Configuration Script for Current Sharing With Single-Pin Enable**

COMMAND NAME	CODE	WRITE BYTE	COMMENT
PAGE	00h		Selects all
PIN_CONFIG_00	D2h		Single ENABLE
SEQUENCE_CONFIG <sup>(1)</sup>	D4h		Enable PGOOD dependence (manufacturer default)
PAGE	00h		Selects SW1 to SW2 pair
PIN_CONFIG_01 <sup>(1)</sup>	D3h		Configure SS1/PG1 pin to SS1 for external soft-start (manufacturer default)
SEQUENCE_ORDER	D5h	0x04	First to start, second to stop
TON_TOFF_DELAY	DDh	0x24	100-ms turn-on delay 100-ms turn-off delay
PAGE	00h	0x02	Selects SW3 to SW4 pair
PIN_CONFIG_01 <sup>(1)</sup>	D3h	0x00	Configure SS2/PG2 pin to SS2 for external soft-start (manufacturer default)
SEQUENCE_ORDER	D5h	0x01	Second to start, first to stop
TON_TOFF_DELAY	DDh	0x23	100-ms turn-on delay 25-ms turn-off delay
STORE_DEFAULT_ALL	11h	—	Save settings as default

(1) Only necessary if the defaults have been overwritten since device manufacture.

### 9.2.2.2 Detailed Design Procedure

#### 9.2.2.2.1 Current Sharing Timing Example

Figure 9-12 shows an example configuration in which both the SW1-SW2 pair and SW3-SW4 pair are current shared. The enable pin of the slave converter can either follow the master converter or be floating. For the PGOOD pin, the slave PGOOD follows the master PGOOD. Due to internal pull-ups to VDD on ENSWx lines, the user has an option to control ENSWx if an always on condition is desired.

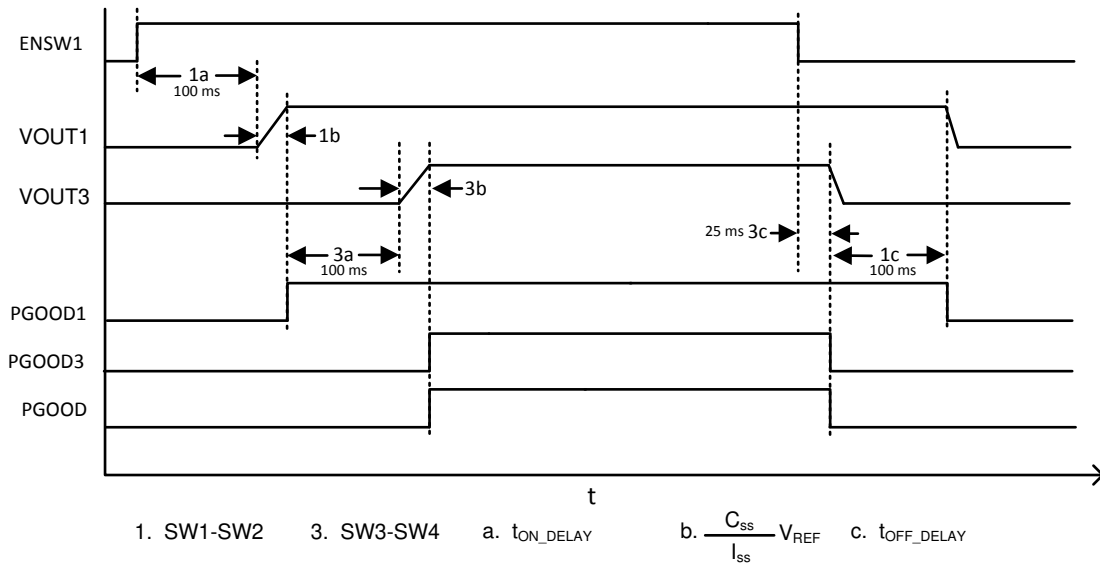

A. External soft-start, single ENABLE

**Figure 9-12. Example Timing Diagram for Current Sharing With Single-Pin Enable**

### 9.2.3 External Sequencing Application

Figure 9-13 shows an example configuration where the VOUT outputs are linked to enable terminal ENSWx inputs in a daisy-chain configuration for start sequence SW1-SW2-SW3-SW4.

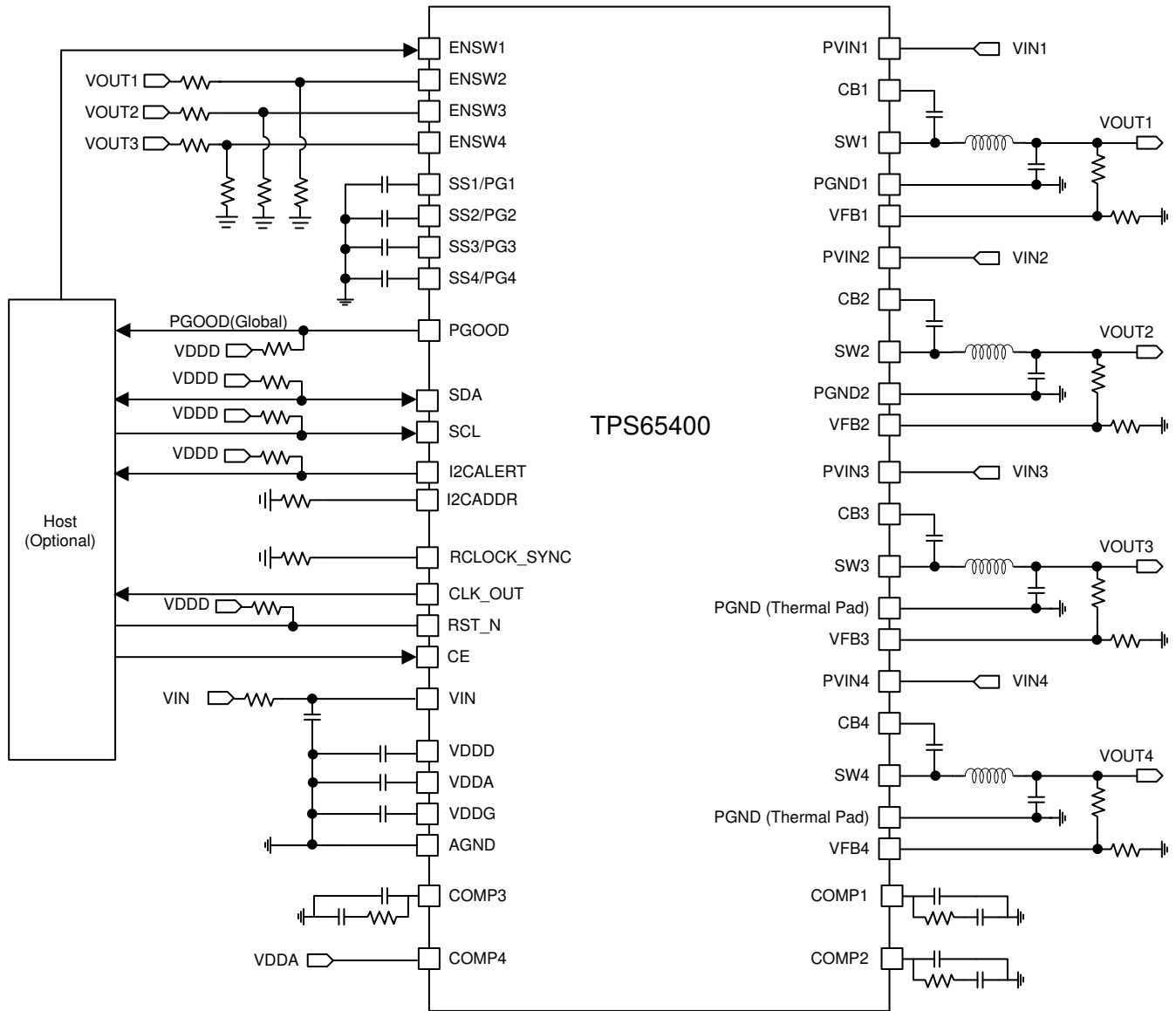

A. Sequencing through  $\overline{VOUT}$

Figure 9-13. External Sequencing Schematic,  $\overline{VOUT} > VEN$

### 9.2.3.1 Design Requirements

Table 9-5 and Table 9-6 list PMBus commands to configure this device.

**Table 9-5. PMBus Commands Used for External Sequencing through  $\overline{\text{VOUT}}$**

COMMAND NAME	CODE	NAME	BITS	COMMENT
PAGE	00h	—	7:0	Selects output rail
STORE_DEFAULT_ALL	11h	—	—	Save settings as default
PIN_CONFIG_00	D2h	PGOOD_PIN_CONFIG <sup>(1)</sup>	6:2	PGOOD pin and of all $\overline{\text{PGOOD}}$ (manufacturer default)
		ENABLE_PIN_CONFIG <sup>(1)</sup>	1:0	Active ENABLE (manufacturer default)
PIN_CONFIG_01	D3h	SSPG_PIN_CONFIG <sup>(1)</sup>	0	Set to SSx for external soft-start (manufacturer default)
TON_TOFF_DELAY	DDh	TON_DELAY	5:3	Delay time before starting
		TOFF_DELAY <sup>(1)</sup>	2:0	Delay time before stopping
RESET_DELAY	DCh	RESET_DELAY <sup>(1)</sup>	2:0	Reset delay time

(1) Only necessary if the defaults have been overwritten since device manufacture.

To achieve the timing requirements shown in Table 9-5, see Table 9-6 for an example configuration script.

**Table 9-6. Example Configuration Script for External Sequencing through  $\overline{\text{VOUT}}$**

COMMAND NAME	CODE	WRITE BYTE	COMMENT
PAGE	00h	0xFF	Selects all
PIN_CONFIG_00 <sup>(1)</sup>	D2h	0x3C	Active ENABLE (manufacturer default)
RESET_DELAY <sup>(1)</sup>	DCh	0x02	100-ms reset delay
PAGE	00h	0x00	Selects SW1
PIN_CONFIG_01 <sup>(1)</sup>	D3h	0x00	Configure SS1/PG1 pin to SS1 for external soft-start
TON_TOFF_DELAY	DDh	0x20	100-ms turn-on delay 0-ms turn-off delay
PAGE	00h	0x01	Selects SW2
PIN_CONFIG_01 <sup>(1)</sup>	D3h	0x00	Configure SS2/PG2 pin to SS2 for external soft-start
TON_TOFF_DELAY	DDh	0x20	100-ms turn-on delay 0-ms turn-off delay
PAGE	00h	0x02	Selects SW3
PIN_CONFIG_01 <sup>(1)</sup>	D3h	0x00	Configure SS3/PG3 pin to SS3 for external soft-start
TON_TOFF_DELAY	DDh	0x20	100-ms turn-on delay 0-ms turn-off delay
PAGE	00h	0x03	Selects SW4
PIN_CONFIG_01 <sup>(1)</sup>	D3h	0x00	Configure SS4/PG4 pin to SS4 for external soft-start
TON_TOFF_DELAY	DDh	0x20	100-ms turn-on delay 0-ms turn-off delay
STORE_DEFAULT_ALL	11h	—	Save settings as default

### 9.2.3.2 Detailed Design Procedure

#### 9.2.3.2.1 External Sequencing Through $\overline{\text{PG}}$ Pins

In an application where the programmable soft-start ramping rate is sufficient and where stop sequencing is not required, it is possible to wire Power Good pins (global PGOOD, PG) to enable pins (ENSW<sub>x</sub>) according to the desired start sequence. This is useful in cases where multiple PMUs are configured and the PG or global PGOOD output of one PMU is required to turn on an output of another PMU.

#### 9.2.3.2.2 External Sequencing Through $\overline{\text{SW}}$

In an application where output voltages exceed the threshold voltage of the enable pins ENSW<sub>x</sub>, it is possible to wire a properly divided VOUT directly to the enable pins according to the desired start sequence.

9.2.3.2.3 Example Configuration

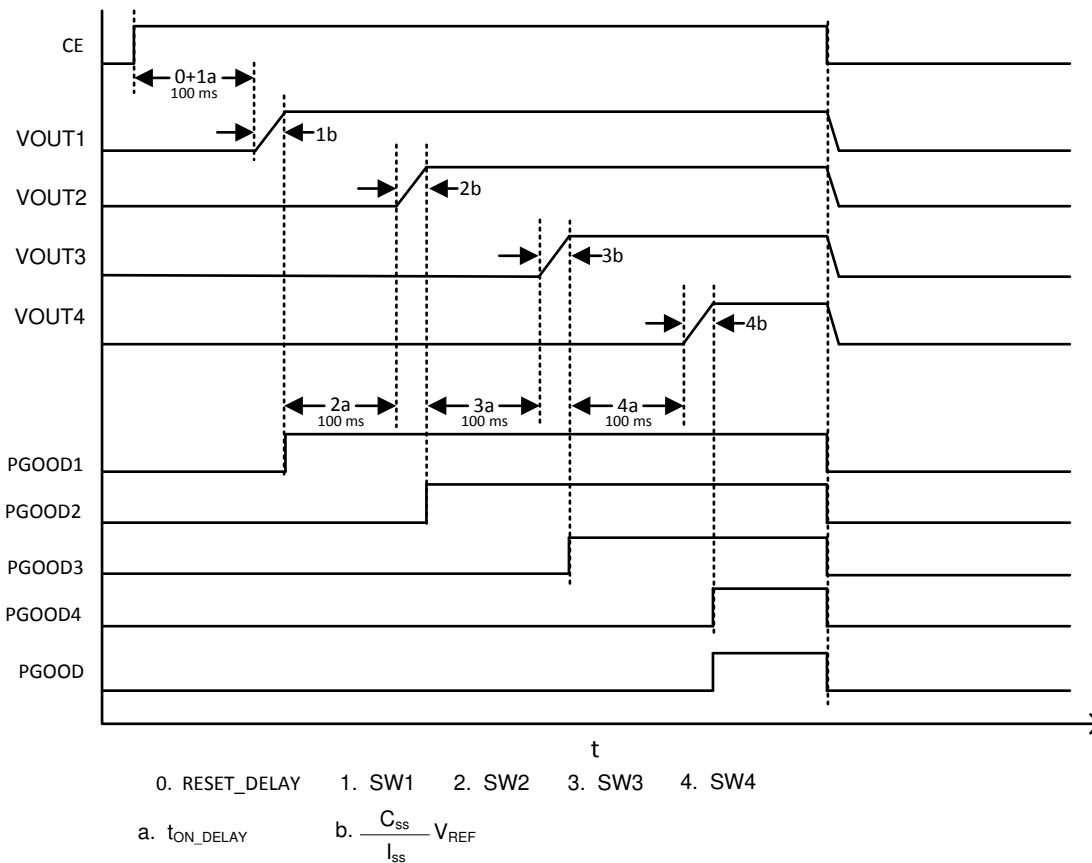

**Figure 9-14. Example Timing Diagram for External Sequencing Through VOUT**

**Note**

Only necessary if the defaults have been overwritten since device manufacture.

## 10 Power Supply Recommendations

This device is designed to operate from an input voltage supply range between 4.5 and 18 V. This input power supply should be well regulated. If the input supply is located more than a few inches from the TPS65400 converter, additional bulk capacitance may be required in addition to the ceramic bypass capacitors. An electrolytic capacitor with a value of 47  $\mu\text{F}$  is a typical choice.

## 11 Layout

### 11.1 Layout Guidelines

Layout is a critical portion of high-current multi-channel DC-DC. Follow these guidelines for layout. See [Section 11.2](#) for a PCB layout example.

- Place VOUT and SW on the top layer and an inner power plane for VIN.
- Also on the top layer, fit connections for the remaining pins of TPS65400 and a large top-side area filled with ground.
- Connect the top layer ground area to the internal ground layer or layers using vias at the input bypass capacitor, the output filter capacitor, and directly under the TPS65400 device to provide a thermal path from the power pad to ground.
- Tie the AGND pin directly to the power pad under the IC.
- For operation at full-rated load, the top-side ground area together with the internal ground plane must provide adequate heat dissipating area.
- Several signals paths conduct fast-changing currents or voltages that can interact with stray inductance or parasitic capacitance to generate noise or degrade the power supplies' performance. To help eliminate these problems, bypass the VIN pin to ground with a low-ESR ceramic bypass capacitor with X5R or X7R dielectric. Take care to minimize the loop area formed by the bypass capacitor connections, the VIN pins, and the ground connections. Because the SW connection is the switching node, the output inductor should be located close to the SW pins, and the area of the PCB conductor minimized to prevent excessive capacitive coupling.
- The output filter capacitor ground should use the same power ground trace as the VIND input bypass capacitor. Try to minimize this conductor length while maintaining adequate width.
- The compensation should be as close as possible to the COMP pins. The COMP and ROSC pins are sensitive to noise so the components associated to these pins should be located as close as possible to the IC and routed with minimal lengths of trace.
- The VFB node is a high-impedance analog node which is easier to pick noise on board. Keep FB node trace as short as possible.

## 11.2 Layout Example

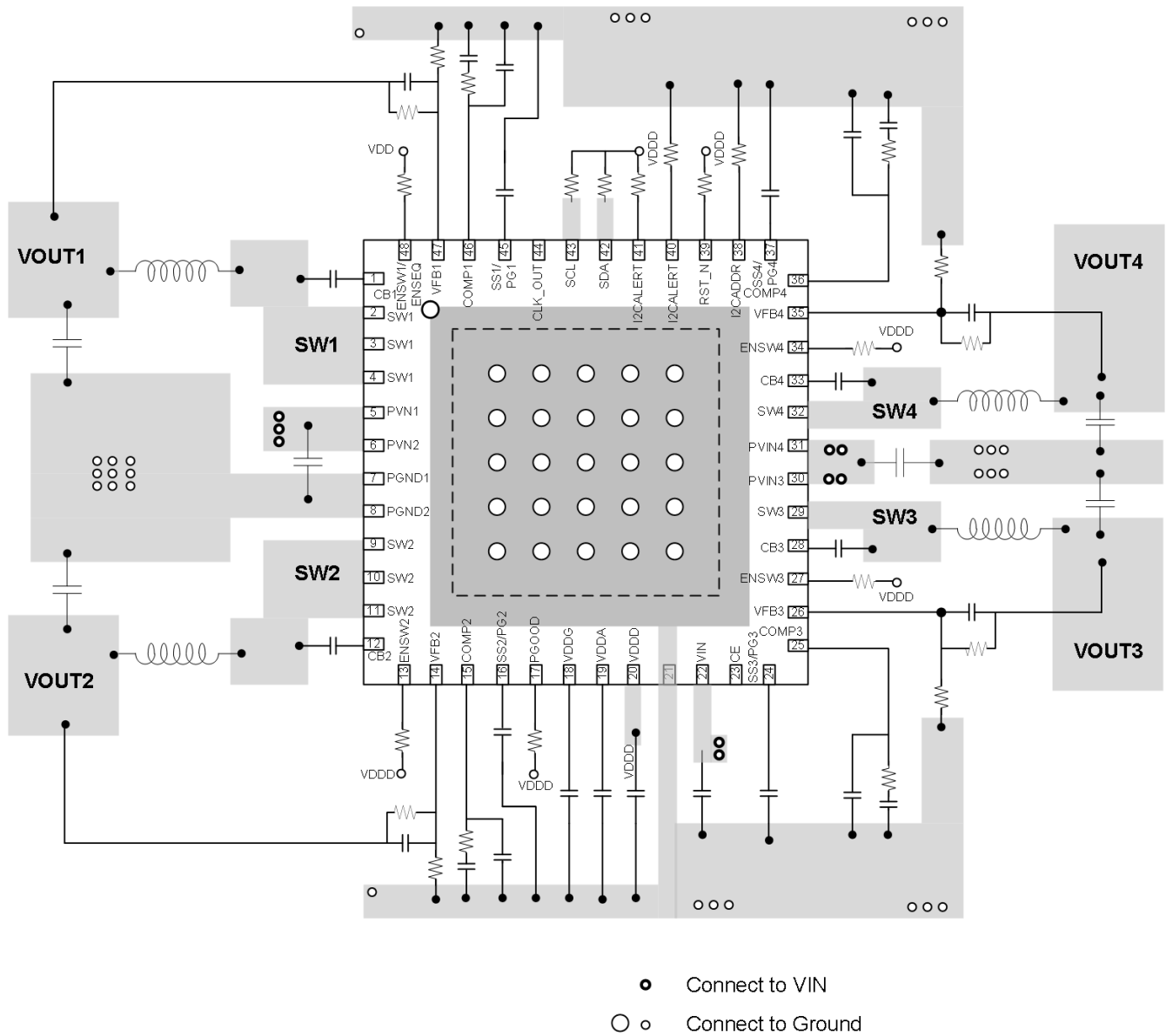

**Figure 11-1. Layout Schematic**

## 12 Device and Documentation Support

### 12.1 Documentation Support

#### 12.1.1 Related Documentation

- *PMBus Power System Management Protocol Specification Part I – General Requirements, Transport and Electrical Interface*, Revision 1.2, dated 6 September 2010, published by the Power Management Bus Implementers Forum (<http://pmbus.org/Specifications>).

#### 12.1.2 Related Parts

PART NUMBER	DESCRIPTION	COMMENTS
TPS65262	4.5- to 18-V, triple buck with dual adjustable LDOs	Triple buck 3-A/1-A/1-A output current, dual LDOs 100-mA/200-mA output current, automatic power sequencing
TPS65263	4.5- to 18-V, triple buck with I <sup>2</sup> C interface	Triple buck 3-A/2-A/2-A output current, I <sup>2</sup> C-controlled dynamic voltage scaling (DVS)
TPS65651-1/2/3	4.5- to 18-V, triple buck with different PGOOD deglitch time	Triple buck 3-A/2-A/2-A output current, support 1-s, 32-ms, and 256-ms PGOOD deglitch time, adjustable current limit setting by external resistor
TPS65287	4.5- to 18-V, triple buck with power switch and push-button control	Triple buck 3-A/2-A/2-A output current, up to 2.1-A USB power with overcurrent setting by external resistor, push-button control for intelligent system power-on/power-off operation
TPS65288	4.5- to 18-V, triple buck with dual power switches	Triple buck 3-A/2-A/2-A output current, 2 USB power switches current limiting at typical 1.2 A (0.8/1/1.4/1.6/1.8/2/2.2 A available with manufacture trim options)

### 12.2 Receiving Notification of Documentation Updates

To receive notification of documentation updates, navigate to the device product folder on [ti.com](http://ti.com). Click on *Subscribe to updates* to register and receive a weekly digest of any product information that has changed. For change details, review the revision history included in any revised document.

### 12.3 Glossary

[TI Glossary](#) This glossary lists and explains terms, acronyms, and definitions.

### 12.4 Trademarks

All trademarks are the property of their respective owners.

### 12.5 Electrostatic Discharge Caution



This integrated circuit can be damaged by ESD. Texas Instruments recommends that all integrated circuits be handled with appropriate precautions. Failure to observe proper handling and installation procedures can cause damage.

ESD damage can range from subtle performance degradation to complete device failure. Precision integrated circuits may be more susceptible to damage because very small parametric changes could cause the device not to meet its published specifications.

### 12.6 Glossary

[TI Glossary](#) This glossary lists and explains terms, acronyms, and definitions.

## 13 Mechanical, Packaging, and Orderable Information

The following pages include mechanical, packaging, and orderable information. This information is the most current data available for the designated devices. This data is subject to change without notice and revision of this document. For browser-based versions of this data sheet, refer to the left-hand navigation.

**PACKAGING INFORMATION**

Orderable part number	Status (1)	Material type (2)	Package   Pins	Package qty   Carrier	RoHS (3)	Lead finish/ Ball material (4)	MSL rating/ Peak reflow (5)	Op temp (°C)	Part marking (6)
<a href="#">TPS65400RGZR</a>	Active	Production	VQFN (RGZ)   48	2500   LARGE T&R	Yes	NIPDAU	Level-3-260C-168 HR	-40 to 85	TPS65400
<a href="#">TPS65400RGZT</a>	Active	Production	VQFN (RGZ)   48	250   SMALL T&R	Yes	NIPDAU	Level-3-260C-168 HR	-40 to 85	TPS65400

(1) **Status:** For more details on status, see our [product life cycle](#).

(2) **Material type:** When designated, preproduction parts are prototypes/experimental devices, and are not yet approved or released for full production. Testing and final process, including without limitation quality assurance, reliability performance testing, and/or process qualification, may not yet be complete, and this item is subject to further changes or possible discontinuation. If available for ordering, purchases will be subject to an additional waiver at checkout, and are intended for early internal evaluation purposes only. These items are sold without warranties of any kind.

(3) **RoHS values:** Yes, No, RoHS Exempt. See the [TI RoHS Statement](#) for additional information and value definition.

(4) **Lead finish/Ball material:** Parts may have multiple material finish options. Finish options are separated by a vertical ruled line. Lead finish/Ball material values may wrap to two lines if the finish value exceeds the maximum column width.

(5) **MSL rating/Peak reflow:** The moisture sensitivity level ratings and peak solder (reflow) temperatures. In the event that a part has multiple moisture sensitivity ratings, only the lowest level per JEDEC standards is shown. Refer to the shipping label for the actual reflow temperature that will be used to mount the part to the printed circuit board.

(6) **Part marking:** There may be an additional marking, which relates to the logo, the lot trace code information, or the environmental category of the part.

Multiple part markings will be inside parentheses. Only one part marking contained in parentheses and separated by a "~" will appear on a part. If a line is indented then it is a continuation of the previous line and the two combined represent the entire part marking for that device.

**Important Information and Disclaimer:**The information provided on this page represents TI's knowledge and belief as of the date that it is provided. TI bases its knowledge and belief on information provided by third parties, and makes no representation or warranty as to the accuracy of such information. Efforts are underway to better integrate information from third parties. TI has taken and continues to take reasonable steps to provide representative and accurate information but may not have conducted destructive testing or chemical analysis on incoming materials and chemicals. TI and TI suppliers consider certain information to be proprietary, and thus CAS numbers and other limited information may not be available for release.

In no event shall TI's liability arising out of such information exceed the total purchase price of the TI part(s) at issue in this document sold by TI to Customer on an annual basis.

**OTHER QUALIFIED VERSIONS OF TPS65400 :**

- Automotive : [TPS65400-Q1](#)

**NOTE: Qualified Version Definitions:**

- Automotive - Q100 devices qualified for high-reliability automotive applications targeting zero defects

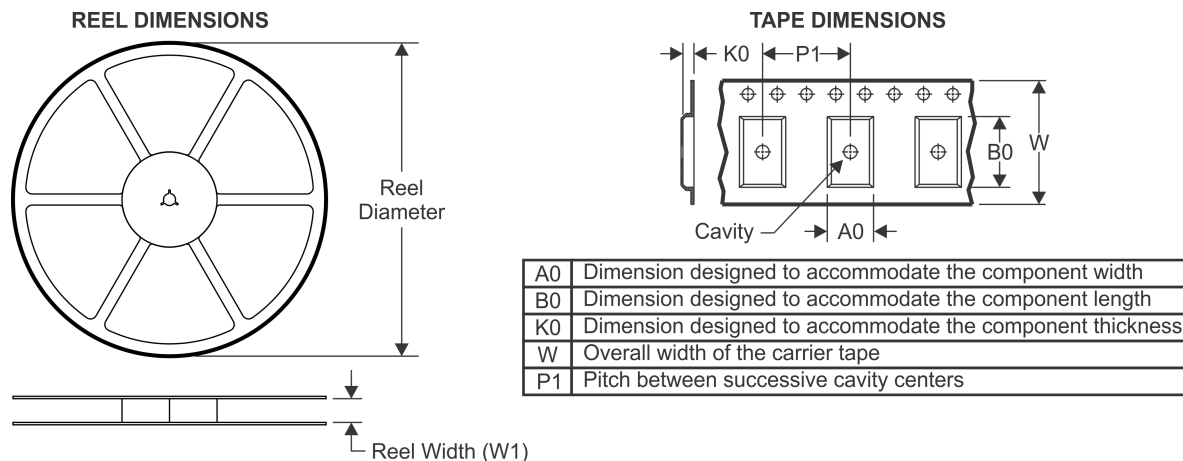
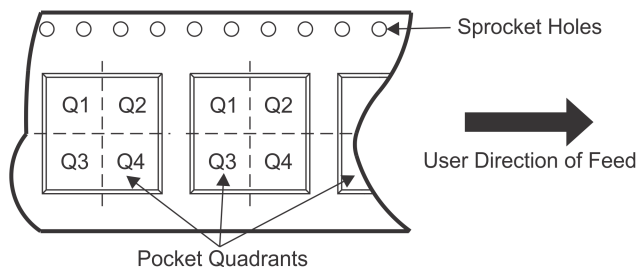
**TAPE AND REEL INFORMATION**

**QUADRANT ASSIGNMENTS FOR PIN 1 ORIENTATION IN TAPE**

\*All dimensions are nominal

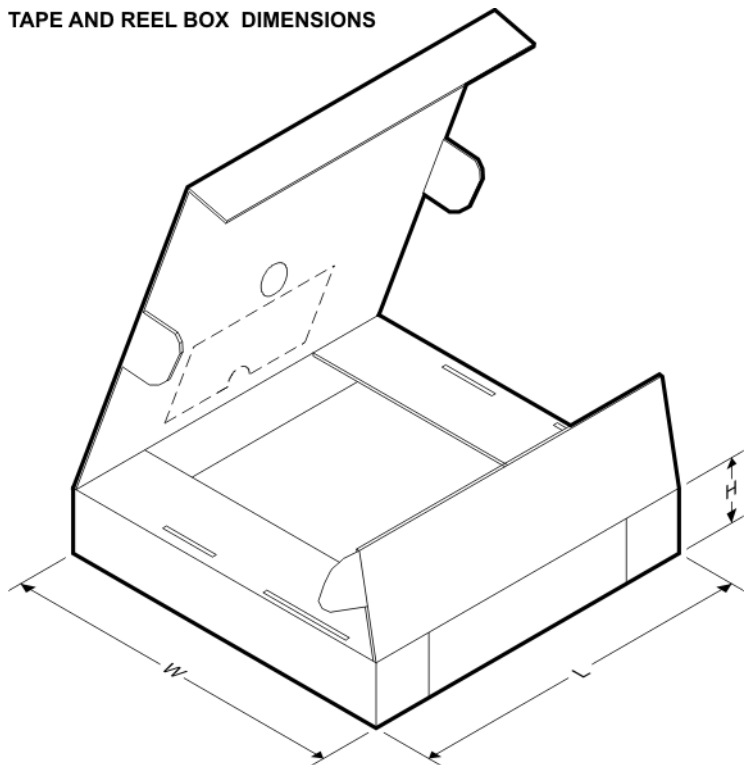
Device	Package Type	Package Drawing	Pins	SPQ	Reel Diameter (mm)	Reel Width W1 (mm)	A0 (mm)	B0 (mm)	K0 (mm)	P1 (mm)	W (mm)	Pin1 Quadrant
TPS65400RGZR	VQFN	RGZ	48	2500	330.0	16.4	7.3	7.3	1.1	12.0	16.0	Q2
TPS65400RGZT	VQFN	RGZ	48	250	180.0	16.4	7.3	7.3	1.1	12.0	16.0	Q2

**TAPE AND REEL BOX DIMENSIONS**

\*All dimensions are nominal

Device	Package Type	Package Drawing	Pins	SPQ	Length (mm)	Width (mm)	Height (mm)
TPS65400RGZR	VQFN	RGZ	48	2500	367.0	367.0	38.0
TPS65400RGZT	VQFN	RGZ	48	250	210.0	185.0	35.0

## GENERIC PACKAGE VIEW

**RGZ 48**

**VQFN - 1 mm max height**

7 x 7, 0.5 mm pitch

PLASTIC QUADFLAT PACK- NO LEAD

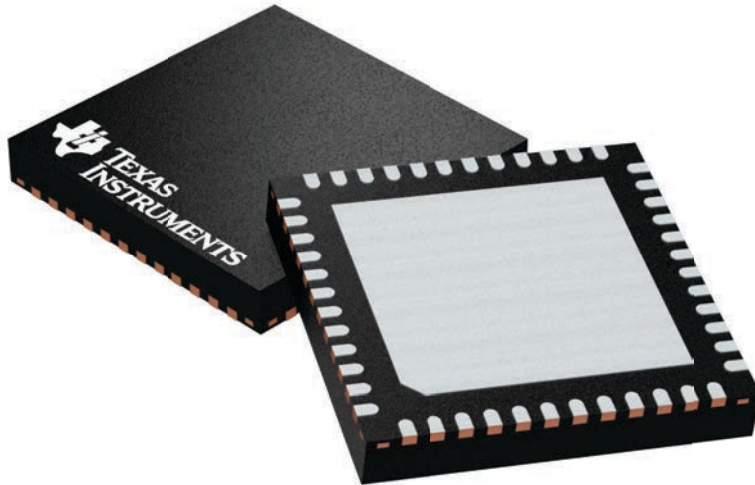

Images above are just a representation of the package family, actual package may vary.  
Refer to the product data sheet for package details.

4224671/A

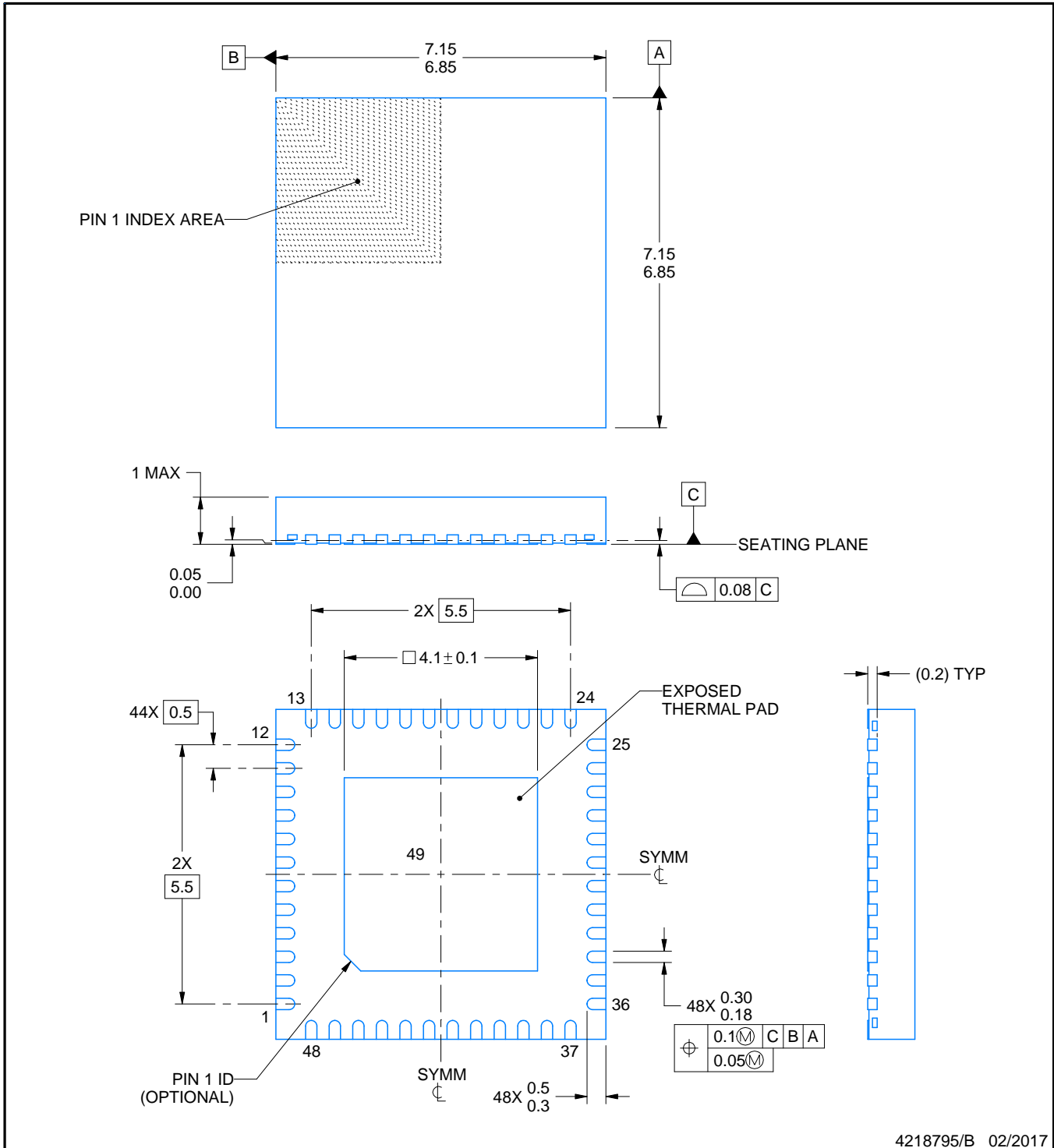
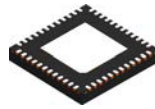

4218795/B 02/2017

NOTES:

1. All linear dimensions are in millimeters. Any dimensions in parenthesis are for reference only. Dimensioning and tolerancing per ASME Y14.5M.
2. This drawing is subject to change without notice.
3. The package thermal pad must be soldered to the printed circuit board for thermal and mechanical performance.

# EXAMPLE BOARD LAYOUT

**RGZ0048B**

**VQFN - 1 mm max height**

PLASTIC QUAD FLATPACK - NO LEAD

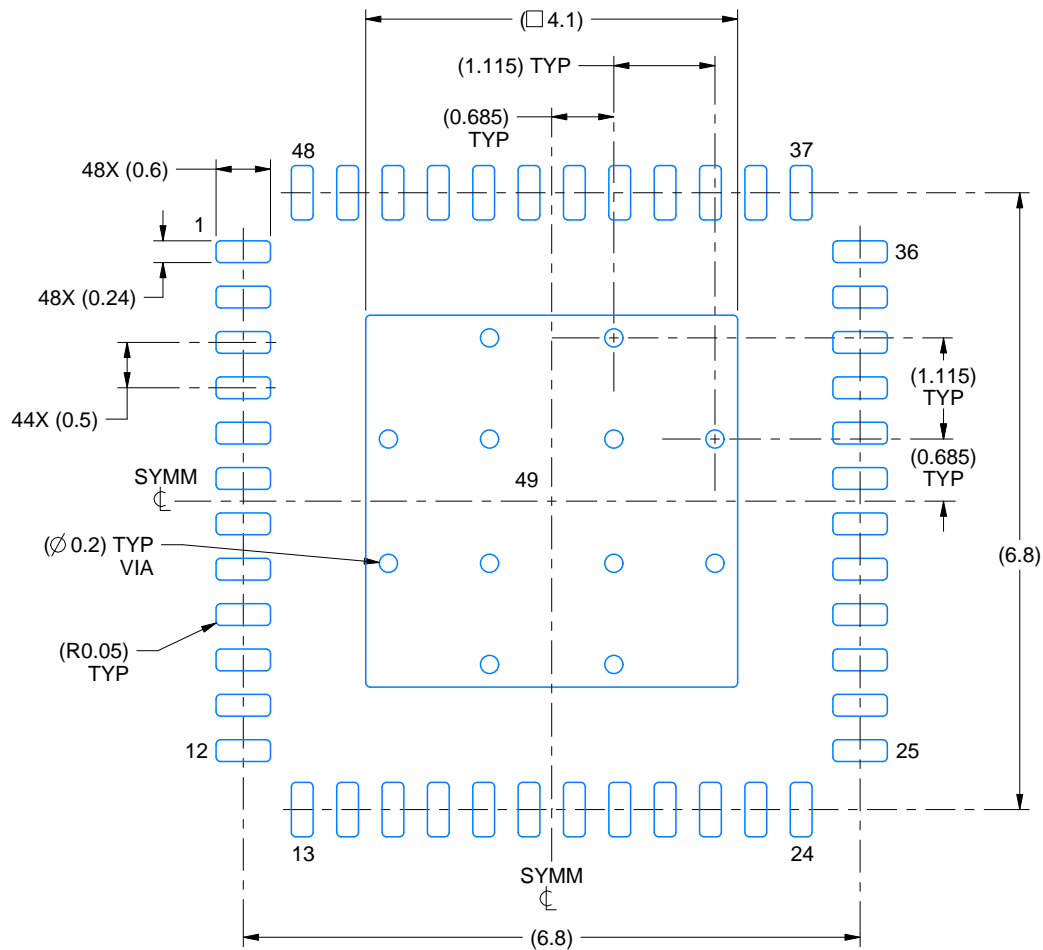

**LAND PATTERN EXAMPLE**  
EXPOSED METAL SHOWN  
SCALE:12X

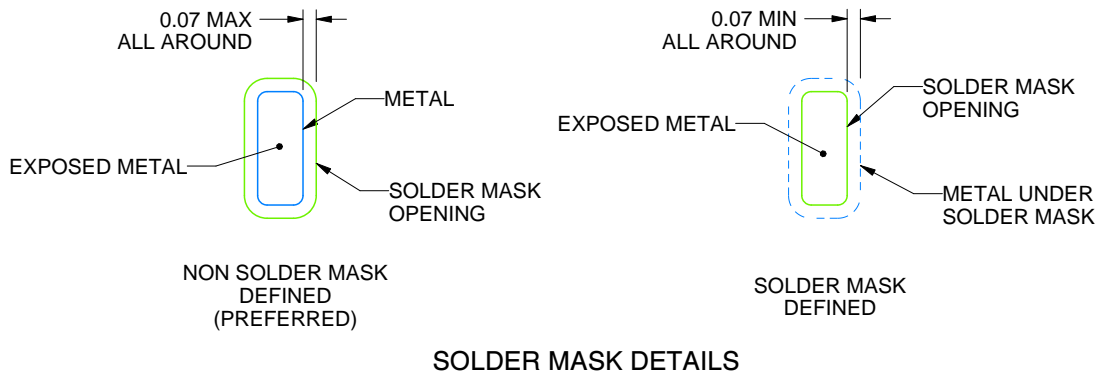

**SOLDER MASK DETAILS**

4218795/B 02/2017

NOTES: (continued)

4. This package is designed to be soldered to a thermal pad on the board. For more information, see Texas Instruments literature number SLUA271 ([www.ti.com/lit/sluea271](http://www.ti.com/lit/sluea271)).
5. Vias are optional depending on application, refer to device data sheet. If any vias are implemented, refer to their locations shown on this view. It is recommended that vias under paste be filled, plugged or tented.

# EXAMPLE STENCIL DESIGN

RGZ0048B

VQFN - 1 mm max height

PLASTIC QUAD FLATPACK - NO LEAD

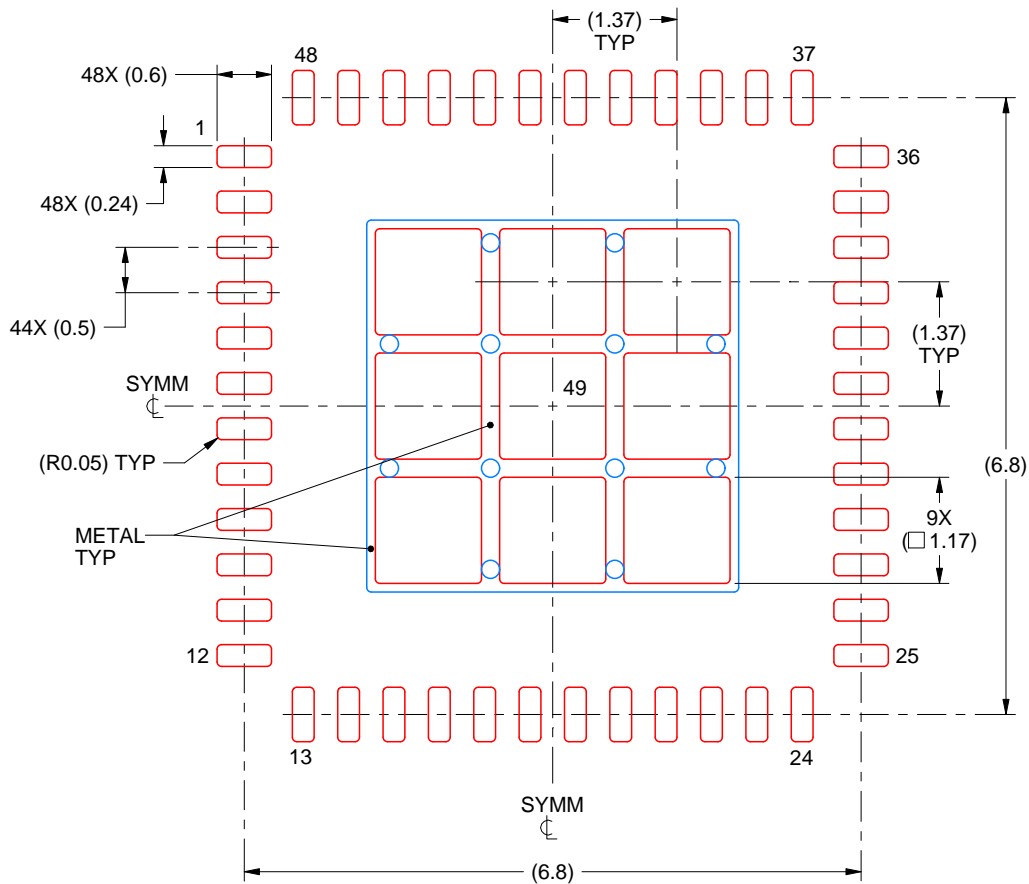

**SOLDER PASTE EXAMPLE**  
 BASED ON 0.125 mm THICK STENCIL

EXPOSED PAD 49  
 73% PRINTED SOLDER COVERAGE BY AREA UNDER PACKAGE  
 SCALE:12X

4218795/B 02/2017

NOTES: (continued)

6. Laser cutting apertures with trapezoidal walls and rounded corners may offer better paste release. IPC-7525 may have alternate design recommendations.

## IMPORTANT NOTICE AND DISCLAIMER

TI PROVIDES TECHNICAL AND RELIABILITY DATA (INCLUDING DATA SHEETS), DESIGN RESOURCES (INCLUDING REFERENCE DESIGNS), APPLICATION OR OTHER DESIGN ADVICE, WEB TOOLS, SAFETY INFORMATION, AND OTHER RESOURCES "AS IS" AND WITH ALL FAULTS, AND DISCLAIMS ALL WARRANTIES, EXPRESS AND IMPLIED, INCLUDING WITHOUT LIMITATION ANY IMPLIED WARRANTIES OF MERCHANTABILITY, FITNESS FOR A PARTICULAR PURPOSE OR NON-INFRINGEMENT OF THIRD PARTY INTELLECTUAL PROPERTY RIGHTS.

These resources are intended for skilled developers designing with TI products. You are solely responsible for (1) selecting the appropriate TI products for your application, (2) designing, validating and testing your application, and (3) ensuring your application meets applicable standards, and any other safety, security, regulatory or other requirements.

These resources are subject to change without notice. TI grants you permission to use these resources only for development of an application that uses the TI products described in the resource. Other reproduction and display of these resources is prohibited. No license is granted to any other TI intellectual property right or to any third party intellectual property right. TI disclaims responsibility for, and you will fully indemnify TI and its representatives against, any claims, damages, costs, losses, and liabilities arising out of your use of these resources.

TI's products are provided subject to [TI's Terms of Sale](#) or other applicable terms available either on [ti.com](https://www.ti.com) or provided in conjunction with such TI products. TI's provision of these resources does not expand or otherwise alter TI's applicable warranties or warranty disclaimers for TI products.

TI objects to and rejects any additional or different terms you may have proposed.

Mailing Address: Texas Instruments, Post Office Box 655303, Dallas, Texas 75265

Copyright © 2025, Texas Instruments Incorporated