

IB IL 400 BR - Inline terminal

2727394

<https://www.phoenixcontact.com/us/products/2727394>

Please be informed that the data shown in this PDF document is generated from our online catalog. Please find the complete data in the user documentation. Our general terms of use for downloads are valid.



Inline extension module, for brake control in conjunction with Inline power level terminals, brake module for 440 V DC or 440 V AC brakes

Product description

The brake module is a passive, electronic brake control switch which can be snapped on the power-level terminal block using a 3-pos. inverted COMBICON plug.

The connection to the brake is made using a 2-pos. COMBICON plug with a connection cross section of up to 2.5 mm².

Your advantages

- Connection option for an external passive brake module
- Hand-held operator panel mode
- Integrated electronic motor protection in accordance with IEC 60947-4
- Diagnostic and status indicators
- Safe isolation between mains voltage and 24 V supply voltage in accordance with EN 50178
- Motor control via OUT process data
- Motor current monitoring

Commercial data

Item number	2727394
Packing unit	1 pc
Minimum order quantity	1 pc
Sales key	NULL
Product key	DRI172
GTIN	4017918168469
Weight per piece (including packing)	100.1 g
Weight per piece (excluding packing)	91 g
Customs tariff number	85389091
Country of origin	DE

Technical data

Product properties

Product type	Extension module
Product family	Inline
Type	Inline
No. of channels	1

Insulation characteristics

Protection class	I (IEC 61140, EN 61140, VDE 0140-1)
------------------	-------------------------------------

Electrical properties

Switch-on delay	< 4 ms
Test section	24 V supply (U_S), GND, brake control/protective earth ground (PE) 500 V AC 50 Hz 1 min
	24 V supply (U_S), GND, brake control/brake output 500 V AC 50 Hz 1 min
	Brake output/protective earth ground (PE) 500 V AC 50 Hz 1 min

Brake to be connected

Connection name	Connection of the brake to the brake module
Connection method	COMBICON connectors
Cross section	2.5 mm ² (maximum conductor cross section)
Protective circuit	Surge voltage suppression > 750 V
Contact connection type	Unpolarized semiconductor switch
Connection voltage	20 V AC ... 440 V AC (no tolerances permitted)
	12 V DC ... 440 V DC (no tolerances permitted)
Residual voltage	3.4 V (maximum)

Brake module

Connection name	Connection to the power-level terminal block
Connection method	3-pos. COMBICON
Control voltage	24 V DC (= U_S from the power-level terminal block)
Control current	17 mA
Active current limitation	Through resistor

Output data

Residual voltage	3.4 V (maximum)
------------------	-----------------

Connection data

Connection method	COMBICON connectors
-------------------	---------------------

Dimensions

Width	55 mm
Height	57 mm
Depth	16 mm

IB IL 400 BR - Inline terminal



2727394

<https://www.phoenixcontact.com/us/products/2727394>

Environmental and real-life conditions

Ambient conditions

Degree of protection	IP20
Ambient temperature (operation)	-25 °C ... 55 °C (permitted)
Ambient temperature (storage/transport)	-25 °C ... 85 °C (permitted)
Permissible humidity (operation)	75 % ... 85 % (75% average, 85% seldom)
Permissible humidity (storage/transport)	75 % ... 85 % (75% average, 85% seldom)
Air pressure (operation)	80 kPa ... 106 kPa (up to 2000 m above sea level)
Air pressure (storage/transport)	70 kPa ... 106 kPa (up to 3000 m above sea level)

Mounting

Mounting type	In the host system
---------------	--------------------

IB IL 400 BR - Inline terminal

2727394

<https://www.phoenixcontact.com/us/products/2727394>



Drawings

Connection diagram

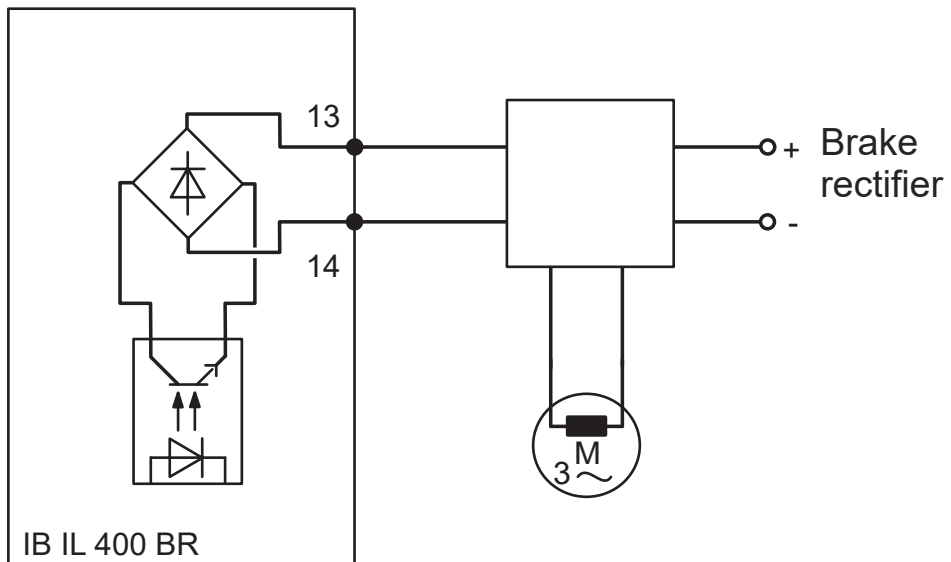

IB IL 400 BR - Inline terminal



2727394

<https://www.phoenixcontact.com/us/products/2727394>

Classifications

ETIM

ETIM 8.0	EC001605
----------	----------

UNSPSC

UNSPSC 21.0	32151600
-------------	----------

2727394

<https://www.phoenixcontact.com/us/products/2727394>

Environmental product compliance

EU RoHS

Fulfills EU RoHS substance requirements	Yes
Exemption	7(a), 7(c)-I

China RoHS

Environment friendly use period (EFUP)	EFUP-50
	An article-related China RoHS declaration table can be found in the download area for the respective article under "Manufacturer declaration". For all articles with EFUP-E, no China RoHS declaration table issued and required.

EU REACH SVHC

REACH candidate substance (CAS No.)	Lead(CAS: n/a)
SCIP	6f4d7f98-d1a9-495a-a5d0-8411c732dd2c

Phoenix Contact 2025 © - all rights reserved

<https://www.phoenixcontact.com>

Phoenix Contact USA
586 Fulling Mill Road
Middletown, PA 17057, United States
(+717) 944-1300
info@phoenixcon.com