



### 1. Features

- For surface mounted applications in order to optimize board space.
- Glass passivated junction
- Low inductance
- Plastic package has Underwriters Laboratory Fammability Classification 94V-0
- High temperature soldering : 260°C /10 seconds at terminals
- Meets MSL level 1, per J-STD-020.

Case: SMC(DO-214AB)



### 2. Mechanical Data

- Case:SMC(DO-214AB) molded plastic
- Terminals: plated leads solderable per MIL-STD-750, Method 2026
- Polarity: Color band denotes cathode end
- Mounting position: Any

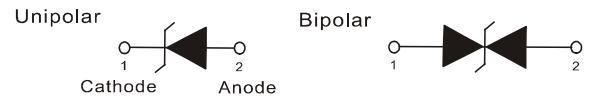

### 3. Maximum Ratings and Electrical Characteristics

Rating at 25°C Ambient temperature unless otherwise specified. Resistive or inductive load,  
For Capacitive load derate current by 20%.

Parameter	Symbol	Value	Unit
Peak pulse power dissipation with a 10/1000 $\mu$ s waveform <sup>(1)</sup> Fig.2	$P_{PPM}$	1500	W
Peak pulse current with a waveform <sup>(1)</sup>	$I_{PPM}$	See next table	A
Power dissipation on infinite heatsink at $T_L=75^\circ\text{C}$	$P_D$	6.5	W
Peak forward surge current 8.3 ms single half sine-wave uni-directional only <sup>(2)</sup>	$I_{FSM}$	200	A
Operating junction and storage temperature range	$T_J, T_{STG}$	-55 to +150	$^\circ\text{C}$

#### Note:

(1) Non-repetitive current pulse per Fig.3 and derated above  $T_A=25^\circ\text{C}$  per Fig.1.

(2) Measured on 8.3 ms single half sine-wave or equivalent square wave, duty cycle=4 pulses per minute maximum.



### 4. Electrical Characteristics (TA=25°C unless otherwise noted)

Part Number (Uni)	Part Number (Bi)	Marking Code		Breakdown Voltage $V_{BR@I_T}$			Maximum Reverse Leakage $I_{R@V_{RWM}}$ (uA)	Working Peak Reverse Voltage $V_{RWM}$ (v)	Maximum Reverse Surge Current $I_{pp(A)}$	Maximum Clamping Voltage $V_{c@I_{pp}}$ (V)
		Uni	Bi	Min(V)	Max(V)	$I_T$ (mA)				
SMCJ5.0A	SMCJ5.0CA	GDE	BDE	6.4	7.0	10	300	5.0	163	9.2
SMCJ6.0A	SMCJ6.0CA	GDG	BDG	6.67	7.37	10	250	6.0	145.6	10.3
SMCJ6.5A	SMCJ6.5CA	GDK	BDK	7.2	8.0	10	150	6.5	134	11.2
SMCJ7.0A	SMCJ7.0CA	GDM	BDM	7.8	8.6	10	100	7.0	125	12
SMCJ7.5A	SMCJ7.5CA	GDP	BDP	8.33	9.21	1	50	7.5	116.3	12.9
SMCJ8.0A	SMCJ8.0CA	GDR	BDR	8.9	9.8	1	30	8.0	110.3	13.6
SMCJ8.5A	SMCJ8.5CA	GDT	BDT	9.44	10.4	1	20	8.5	104.2	14.4
SMCJ9.0A	SMCJ9.0CA	GDV	BDV	10.0	11.1	1	10	9.0	97.4	15.4
SMCJ10A	SMCJ10CA	GDX	BDX	11.1	12.3	1	5	10.0	88.2	17
SMCJ11A	SMCJ11CA	GDZ	BDZ	12.2	13.5	1	2	11.0	82.4	18.2
SMCJ12A	SMCJ12CA	GEE	BEE	13.3	14.7	1	1	12.0	75.4	19.9
SMCJ13A	SMCJ13CA	GEG	BEG	14.4	15.9	1	1	13.0	69.8	21.5
SMCJ14A	SMCJ14CA	GEK	BEK	15.6	17.2	1	1	14.0	64.7	23.2
SMCJ15A	SMCJ15CA	GEM	BEM	16.7	18.5	1	1	15.0	61.5	24.4
SMCJ16A	SMCJ16CA	GEP	BEP	17.8	19.7	1	1	16.0	57.7	26
SMCJ17A	SMCJ17CA	GER	BER	18.9	20.9	1	1	17.0	54.4	27.6
SMCJ18A	SMCJ18CA	GET	BET	20.0	22.1	1	1	18.0	51.4	29.2
SMCJ20A	SMCJ20CA	GEV	BEV	22.2	24.5	1	1	20.0	46.3	32.4
SMCJ22A	SMCJ22CA	GEX	BEX	24.4	26.9	1	1	22.0	42.3	35.5
SMCJ24A	SMCJ24CA	GEZ	BEZ	26.7	29.5	1	1	24.0	38.6	38.9
SMCJ26A	SMCJ26CA	GFE	BFE	28.9	31.9	1	1	26.0	35.6	42.1
SMCJ28A	SMCJ28CA	GFG	BFG	31.1	34.4	1	1	28.0	33.1	45.4
SMCJ30A	SMCJ30CA	GFK	BFK	33.3	36.8	1	1	30.0	31	48.4
SMCJ33A	SMCJ33CA	GFM	BFM	36.7	40.6	1	1	33.0	28.2	53.3
SMCJ36A	SMCJ36CA	GFP	BFP	40.0	44.2	1	1	36.0	25.8	58.1
SMCJ40A	SMCJ40CA	GFR	BFR	44.4	49.1	1	1	40.0	23.3	64.5
SMCJ43A	SMCJ43CA	GFT	BFT	47.8	52.8	1	1	43.0	21.6	69.4
SMCJ45A	SMCJ45CA	GFV	BFV	50.0	55.3	1	1	45.0	20.6	72.7
SMCJ48A	SMCJ48CA	GFX	BFX	53.3	58.9	1	1	48.0	19.4	77.4
SMCJ51A	SMCJ51CA	GFZ	BFZ	56.7	62.7	1	1	51.0	18.2	82.4
SMCJ54A	SMCJ54CA	GGE	BGE	60.0	66.3	1	1	54.0	17.2	87.1
SMCJ58A	SMCJ58CA	GGG	BGG	64.4	71.2	1	1	58.0	16.1	93.6
SMCJ60A	SMCJ60CA	GGK	BGK	66.7	73.7	1	1	60.0	15.5	96.8
SMCJ64A	SMCJ64CA	GGM	BGM	71.1	78.6	1	1	64.0	14.6	103.0
SMCJ70A	SMCJ70CA	GGP	BGP	77.8	86.0	1	1	70.0	13.3	113.0



### 4. Electrical Characteristics (TA=25°C unless otherwise noted)

Part Number (Uni)	Part Number (Bi)	Marking Code		Breakdown Voltage $V_{BR@I_T}$			Maximum Reverse Leakage $I_R@V_{RWM}$ (uA)	Working Peak Reverse Voltage $V_{RWM}$ (V)	Maximum Reverse Surge Current $I_{PP}(A)$	Maximum Clamping Voltage $V_C@I_{PP}(V)$
		Uni	Bi	Min(V)	Max(V)	$I_T(mA)$				
SMCJ75A	SMCJ75CA	GGR	BGR	83.3	92.1	1	1	75.0	12.4	121.0
SMCJ78A	SMCJ78CA	GGT	BGT	86.7	95.8	1	1	78.0	11.9	126.0
SMCJ80A	SMCJ80CA	GGU	BGU	88.8	97.6	1	1	80.0	11.6	129.6
SMCJ85A	SMCJ85CA	GGV	BGV	94.4	104.0	1	1	85.0	10.9	137.0
SMCJ90A	SMCJ90CA	GGX	BGX	100.0	111.0	1	1	90.0	10.3	146.0
SMCJ100A	SMCJ100CA	GGZ	BGZ	111.0	123.0	1	1	100.0	9.3	162.0
SMCJ110A	SMCJ110CA	GHE	BHE	122.0	135.0	1	1	110.0	8.5	177.0
SMCJ120A	SMCJ120CA	GHG	BHG	133.0	147.0	1	1	120.0	7.8	193.0
SMCJ130A	SMCJ130CA	GHK	BHK	144.0	159.0	1	1	130.0	7.2	209.0
SMCJ140A	SMCJ140CA	GHL	BHL	155.0	171.0	1	1	140.0	6.6	226.8
SMCJ150A	SMCJ150CA	GHM	BHM	167.0	185.0	1	1	150.0	6.2	243.0
SMCJ160A	SMCJ160CA	GHP	BHP	178.0	197.0	1	1	160.0	5.8	259.0
SMCJ170A	SMCJ170CA	GHR	BHR	189.0	209.0	1	1	170.0	5.5	275.0
SMCJ180A	SMCJ180CA	GHT	BHT	201.0	222.0	1	1	180.0	5.2	292.0
SMCJ190A	SMCJ190CA	GHU	BHV	211.0	234.0	1	1	190.0	4.9	307.0
SMCJ200A	SMCJ200CA	GHV	BHX	224.0	247.0	1	1	200.0	4.7	324.0
SMCJ210A	SMCJ210CA	GHW	BHZ	233.0	258.0	1	1	210.0	4.5	337.0
SMCJ220A	SMCJ220CA	GHX	BHX	246.0	272.0	1	1	220.0	4.2	356.0
SMCJ250A	SMCJ250CA	GJG	BJG	279.0	309.0	1	1	250.0	3.7	405.0
SMCJ300A	SMCJ300CA	GJK	BJK	335.0	371.0	1	1	300.0	3.1	486.0
SMCJ350A	SMCJ350CA	GJM	BJM	391.0	432.0	1	1	350.0	2.7	567.0
SMCJ400A	SMCJ400CA	GJP	BJP	447.0	494.0	1	1	400.0	2.3	648.0
SMCJ440A	SMCJ440CA	GJR	BJR	492.0	543.0	1	1	440.0	2.1	713.0

#### Note:

① Surge waveform: 10/1000μs

$V_{RWM}$  : Stand-off voltage -- Maximum voltage that can be applied

$V_{BR}$ : Breakdown voltage

$V_C$ : Clamping voltage -- Peak voltage measured across the suppressor at a specified  $I_{PP}$

$I_R$ : Reverse leakage current



### 5. Rating And Characteristic Curves

Fig.1 Derating Curve

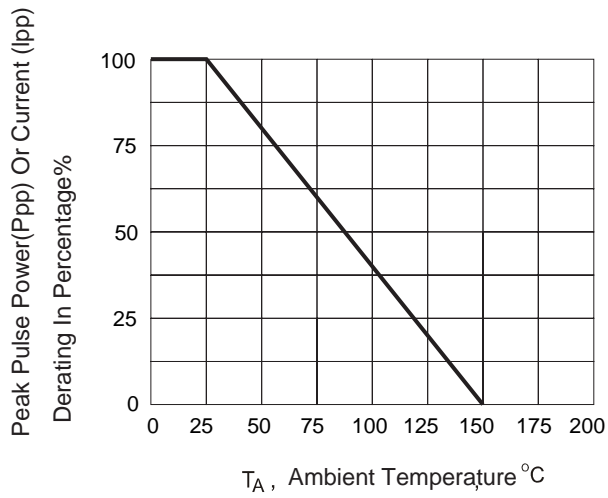

Fig. 2 Peak Pulse Power Rating Curve

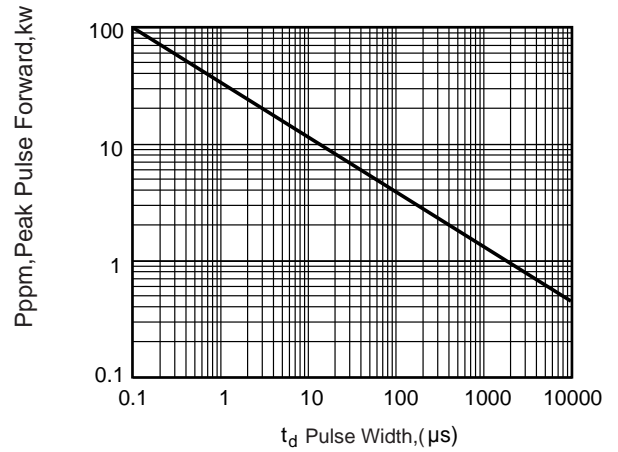

Fig.3 Clamping Power Pulse Waveform

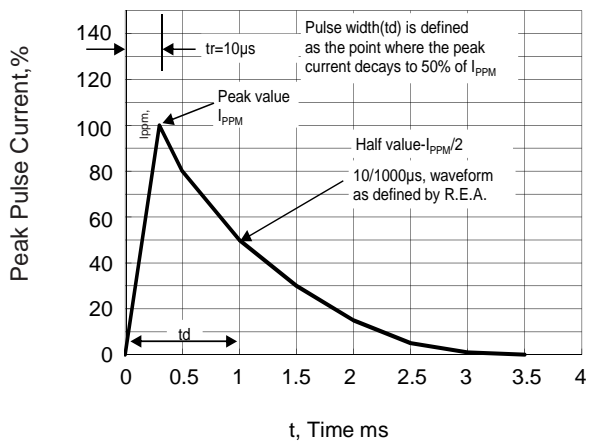
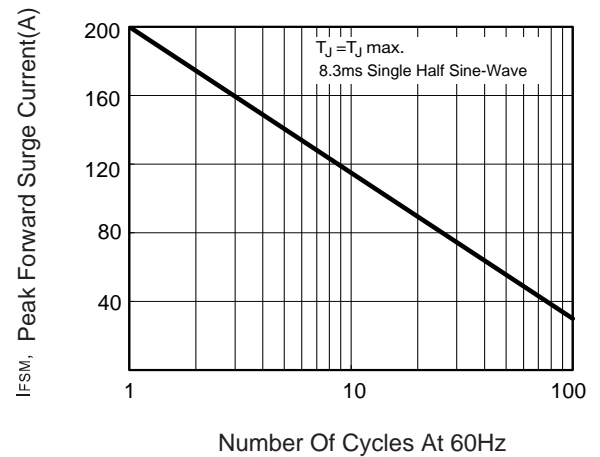

Fig.4 Maximum Non-repetitive Forward Surge Current Unidirectional only





# SMCJ Series

1500W,5.0V - 440V Surface Mount Transient Voltage Suppressor

## 6. Soldering Parameters

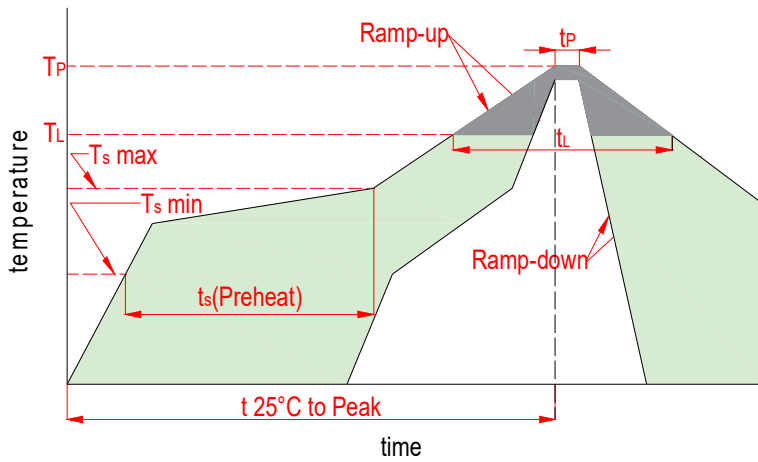

Reflow Condition		Lead-free
Pre Heat	Temp. min( $T_s(\text{min})$ )	150°C
	Temp. max( $T_s(\text{min})$ )	200°C
	Time(min to max)( $t_s$ )	60~120s
Aver. ramp up rate(Liquidus Temp.)( $T_L$ )to peak		3°C/s max
$T_s(\text{max})$ to $T_L$ -Ramp-up Rate		3°C/s max
Reflow	Temp. ( $T_L$ )(Liquidus)	217°C
	Temp. ( $t_L$ )(Liquidus)	60~150s
Peak Temp. ( $T_P$ )		260 <sup>+0/-5</sup> °C
Time within actual peak Temp. ( $t_p$ )		30s max
Ramp-down Rate		6°C/s max
Time 25°C to peak Tempe. ( $T_P$ )		8 minutes max
Do not exceed		260°C

## 7. Dimensions

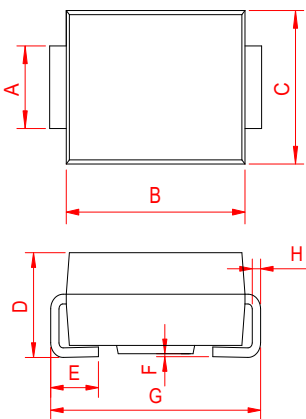

Dimensions	Inches		Millimeters	
	Min	Max	Min	Max
A	0.110	0.126	2.80	3.20
B	0.260	0.280	6.60	7.11
C	0.220	0.245	5.59	6.22
D	0.079	0.103	2.00	2.62
E	0.039	0.063	1.00	1.60
F	0.002	0.008	0.05	0.20
G	0.305	0.320	7.75	8.13
H	0.006	0.014	0.15	0.35

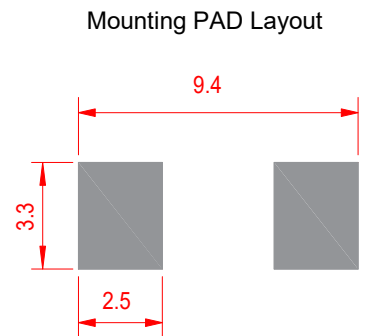

## 8. Part Marking System

Unipolar

Bipolar

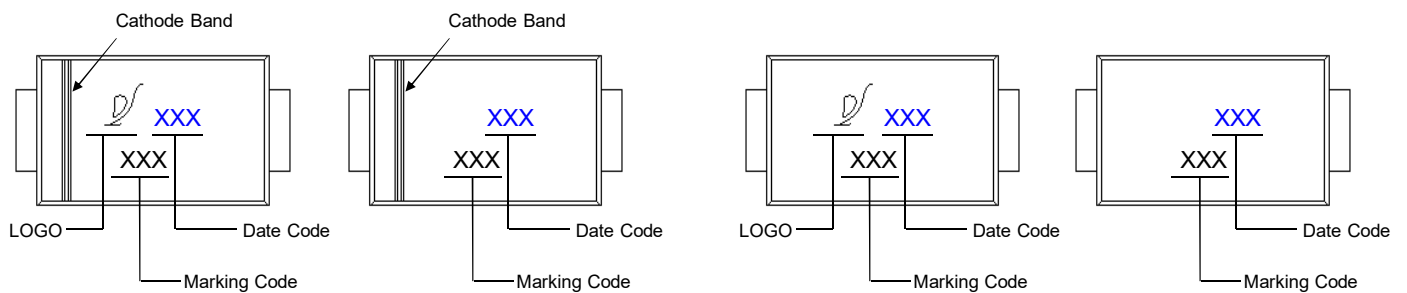

## 9. Package Information

Package	Tape Width (mm)	Reel Size		Quantity(pcs)
		mm	inch	
SMC(DO-214AB)	16	330	13	3000



### Important Notice and Disclaimer

- Reproducing and modifying information of the document is prohibited without from XINNUO.
- XINNUO reserves the right to make changes to this document and its products and specifications.
- XINNUO disclaims any and all liability arising out of the application or use of any product including damages incidentally and consequentially occurred.
- XINNUO does not assume any and all implied warranties, including warranties of fitness for particular purpose, non-infringement and merchantability.
- Applications shown on the here in document are examples of standard use and operation. Customers are responsible in comprehending the suitable use in particular applications.XINNUO makes no representation or warranty that such applications will be suitable for the specified use without further testing or modification.
- The products shown her are not designed and authorized for equipments requiring high level of reliability or relating to human life and for any applications concerning life-saving or life-sustaining, such as medical instruments, transportation equipment, aerospace machinery et cetera. Customers using or selling these products for use in such applications do so at their own risk and agree to fully indemnify XINNUO for any damages resulting from such improper use or sale.
- Since XINNUO uses lot number as the tracking base, please provide the lot number for tracking when complaining.