

# HFD27

# SUBMINIATURE DIP RELAY



File No.:E133481



File No.:R50316277



File No.:CQC09002033393

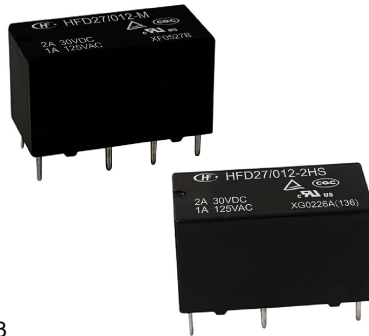

## Features

- 2 Form C configuration
- High switching capacity: 250VA/60W
- Matching 16 pin IC socket
- Bifurcated contacts
- Epoxy sealed for automatic-wave soldering and cleaning

RoHS compliant

## CONTACT DATA

Contact arrangement	2A, 2C
Contact resistance	100mΩ max. (at 10mA 30mVDC)
Contact material	AgNi + Au plated
Contact rating (Res. load)	1A 125VAC, 2A 30VDC 1A 250VAC(70°C, NO) 2A 125VAC(70°C, NO)
Max. switching voltage	250VAC / 120VDC
Max. switching current	2A
Max. switching power	250VA / 60W
Min. applicable load <sup>1)</sup>	10mV 10μA
Mechanical endurance	1x10 <sup>8</sup> OPS
Electrical endurance	1 x 10 <sup>5</sup> OPS (1A 125VAC, Resistive load, at 85°C, 1s on 9s off) 5 x 10 <sup>4</sup> OPS (1A 250VAC, Resistive load, at 70°C, NO, 1s on 9s off) 5 x 10 <sup>4</sup> OPS (2A 125VAC, Resistive load, at 70°C, NO, 1s on 9s off)

**Notes:** 1) Min. applicable load is reference value. Please perform the confirmation test with the actual load before production since reference value may change according to switching frequencies, environmental conditions and expected contact resistance and reliability.

## CHARACTERISTICS

Insulation resistance	1000MΩ (at 500VDC)
Dielectric strength	Between coil & contacts 1500VAC 1min
	Between open contacts M, S type: 1000VAC 1min H type: 750VAC 1min
Operate time (at nomi. volt.)	7ms max.
Release time (at nomi. volt.)	4ms max.
Ambient temperature	-40 C to 85 C
Humidity	5% to 85% RH
Vibration resistance	10Hz to 55Hz 1.5mm DA
Shock resistance	Functional 196m/s <sup>2</sup>
	Destructive 980m/s <sup>2</sup>
Termination	THT
Unit weight	Approx. 5g
Construction	Plastic sealed

**Notes:** 1) The data shown above are initial values.  
2) UL insulation system: Class A.

## COIL DATA

at 23 C

### Standard type (280mW to 580mW)

Coil Code	Coil Voltage VDC <sup>1)</sup>	Initial Pick-up Voltage VDC max. <sup>1)</sup>	Initial Drop-out Voltage VDC min.	Max. Voltage VDC <sup>2)</sup>	Coil Resistance Ω
003-M	3	2.25	0.3	4.5	30 x (1±10%)
005-M	5	3.75	0.5	8.0	90 x (1±10%)
006-M	6	4.50	0.6	10.0	130 x (1±10%)
009-M	9	6.80	0.9	14.5	280 x (1±10%)
012-M	12	9.00	1.2	18.5	450 x (1±10%)
015-M	15	11.3	1.5	22.0	625 x (1±10%)
024-M	24	18.0	2.4	35.5	1600 x (1±10%)
048-M	48	36.0	4.8	56.0	4000 x (1±10%)

## COIL

Coil power	Standard: Approx. 280mW to 580mW Sensitive: Approx. 200mW High Sensitive: Approx. 150mW
Temperature rise	65K max.

## SAFETY APPROVAL RATINGS

UL/CUL	2A 30VDC 1A 125VAC 1A 250VAC(70°C, NO terminal) 2A 125VAC(70°C, NO terminal)
TÜV	2A 30VDC 1A 125VAC

**Notes:** 1) All values unspecified are at 85 C.  
2) Only typical loads are listed above. Other load specifications can be available upon request.



HONGFA RELAY

ISO9001, IATF16949, ISO14001, OHSAS18001, IECQ QC 080000 CERTIFIED

2026 Rev. 1.00

## COIL DATA

at 23 C

### High sensitive type (150mW)

Coil Code	Coil Voltage VDC <sup>1)</sup>	Initial Pick-up Voltage VDC max. <sup>1)</sup>	Initial Drop-out Voltage VDC min.	Max. Voltage VDC <sup>5)</sup>	Coil Resistance $\Omega$
003-H	3	2.4	0.3	7.0	60 x (1±10%)
005-H	5	4.0	0.5	11.5	167 x (1±10%)
006-H	6	4.8	0.6	13.8	240 x (1±10%)
009-H	9	7.2	0.9	20.8	540 x (1±10%)
012-H	12	9.6	1.2	27.7	960 x (1±10%)
015-H	15	12.0	1.5	34.6	1500 x (1±10%)
024-H	24	19.2	2.4	55.2	3840 x (1±10%)

### Sensitive type (200mW)

Coil Code	Coil Voltage VDC <sup>1)</sup>	Initial Pick-up Voltage VDC max. <sup>1)</sup>	Initial Drop-out Voltage VDC min.	Max. Voltage VDC <sup>5)</sup>	Coil Resistance $\Omega$
003-S	3	2.25	0.3	6	45 x (1±10%)
005-S	5	3.75	0.5	10	125 x (1±10%)
006-S	6	4.50	0.6	12	180 x (1±10%)
009-S	9	6.80	0.9	18	405 x (1±10%)
012-S	12	9.00	1.2	24	720 x (1±10%)
015-S	15	11.3	1.5	30	1125 x (1±10%)
024-S	24	18.0	2.4	48	2880 x (1±10%)

Notes:1) The data shown above are initial values.

2) To supply rated step voltage to coil is the foundation of relay proper operation. Please make sure the applied voltage to the coil reach at rated values. Please refer to the typical diagram below for single side stable relay. The "V\_coil" is the rated voltage:

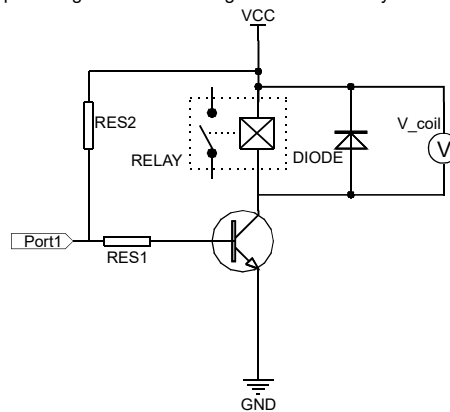

3) In case 5V of transistor drive circuit, it is recommended to use 4.5V type relay, and 3V to use 2.4V type relay.

4) For monostable relays, if you need to drop down voltage and hold mode after reliably operating, make sure that the effective value of holding voltage is not less than 60% of the rated voltage.

5) Maximum voltage refers to the maximum voltage which relay coil could endure in a short period of time.

6) When user's requirements can't be found in the above table, special order allowed.

7) During the relay pick-up or drop-out processes, there are stages of contact pressure change, contact vibration and unstable contact etc. When the voltage applied to coil is gradually changed, it will lengthen the unstable stage and affect relay endurance. To reduce this influence, please apply step voltage (switching circuit) to relay coil.

## ORDERING INFORMATION

Type	HFD27/	012	-2H	-S	(XXX)
Coil voltage	3, 5, 6, 9, 12, 15, 24, 48VDC <sup>1)</sup>				
Contact arrangement	2H: 2 Form A Nil: 2 Form C				
Coil power	M: Standard (280mW to 580mW) S: Sensitive (200mW) H: High sensitive (150mW)				
Special code <sup>2)</sup>	XXX: Customer special requirement		Nil: Standard		

Notes: 1) 48VDC coil voltage is only for standard version.

2) The customer special requirement express as special code after evaluating by Hongfa. For example: (825) indicates that it is suitable for low-level load applications.

3) This product is suitable for wave soldering or manual soldering with a soldering iron.

4) For products that should meet the explosion-proof requirements of "IEC 60079 series", please note [Ex] after the specification while placing orders. Not all products have explosion-proof certification, so please contact us if necessary, in order to select the suitable products.

Outline Dimensions

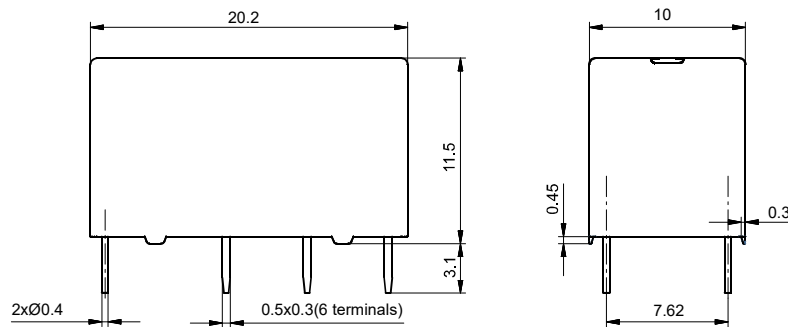

PCB Layout  
(Bottom view)

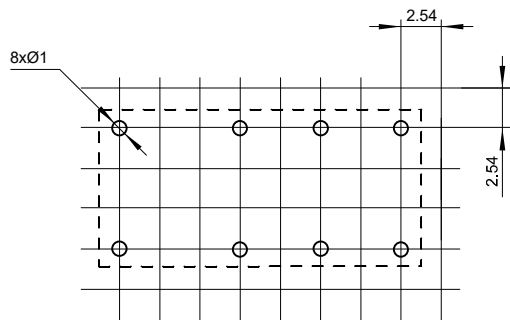

Wiring Diagram  
(Bottom view)

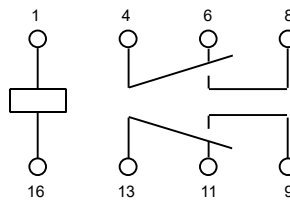

Remark: 1) The pin dimension of the product outline drawing is the size before tinning (it will become larger after tinning), and the mounting hole size is the recommended design size of the PCB board hole. The specific PCB board hole design size can be mapped and adjusted according to the actual product.

2) In case of no tolerance shown in outline dimension: outline dimension  $\leq 1$ mm, tolerance should be  $\pm 0.2$ mm; outline dimension  $> 1$ mm and  $\leq 5$ mm, tolerance should be  $\pm 0.3$ mm; outline dimension  $> 5$ mm, tolerance should be  $\pm 0.4$ mm.

3) The tolerance without indicating for PCB layout is always  $\pm 0.1$ mm.

4) The width of the gridding is 2.54mm.

Outline Dimensions

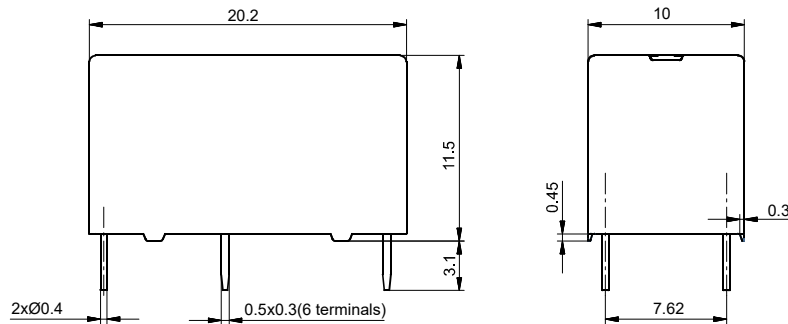

PCB Layout  
(Bottom view)

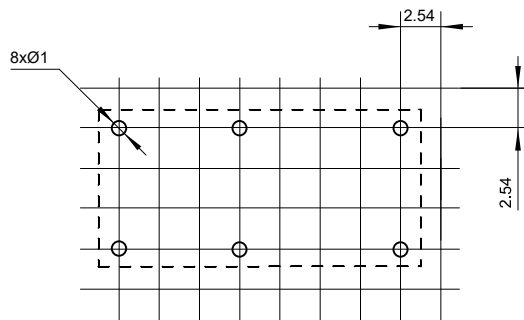

Wiring Diagram  
(Bottom view)

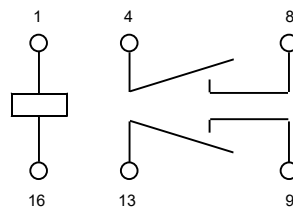

- Remark: 1) The pin dimension of the product outline drawing is the size before tinning (it will become larger after tinning), and the mounting hole size is the recommended design size of the PCB board hole. The specific PCB board hole design size can be mapped and adjusted according to the actual product.
- 2) In case of no tolerance shown in outline dimension: outline dimension  $\leq 1\text{mm}$ , tolerance should be  $\pm 0.2\text{mm}$ ; outline dimension  $> 1\text{mm}$  and  $\leq 5\text{mm}$ , tolerance should be  $\pm 0.3\text{mm}$ ; outline dimension  $> 5\text{mm}$ , tolerance should be  $\pm 0.4\text{mm}$ .
- 3) The tolerance without indicating for PCB layout is always  $\pm 0.1\text{mm}$ .
- 4) The width of the gridding is 2.54mm.

## CHARACTERISTIC CURVES

MAXIMUM SWITCHING POWER

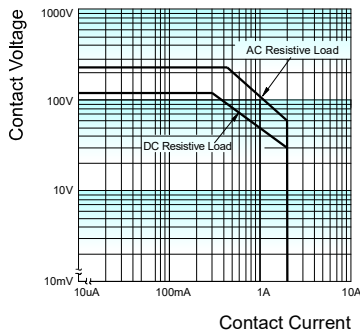

ENDURANCE CURVE

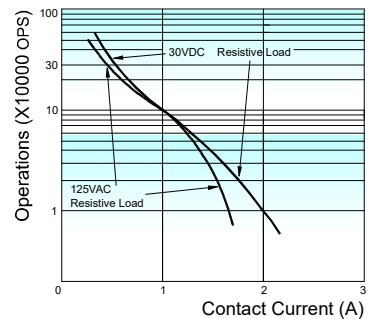

**Test conditions:**

Resistive load, at 85°C, 1s on 9s off.

### Notice

- 1) To avoid using relays under strong magnetic field which will change the parameters of relays such as pick-up voltage and drop-out voltage.
- 2) Energizing coil with rated voltage is basic for normal operation of a relay, please make sure the energized voltage to relay coil have reached the rated voltage.
- 3) For a monosteady state relay, after the relay is reliably operated, if it needs to be kept under pressure, make sure that the effective value of the voltage is not less than 60 % of the rated voltage;
- 4) The relay may be damaged because of falling or when shocking conditions exceed the requirement.
- 5) This product is suitable for wave soldering or manual soldering with a soldering iron.
- 6) Contact is recommended for suitable condition and specifications if water cleaning or surface process is involved in assembling relays on PCB.
- 7) Regarding the plastic sealed relay, we should leave it cooling naturally until below 40°C after welding, then clean it and deal with coating, remarkably the temperature of solvents should also be controlled below 40°C. Please avoid cleaning the relay by ultrasonic, avoid using the solvents like gasoline, Freon, and so on, which would affect the configuration of relay or influence the environment.
- 8) When applied with continuous current, the heat from relay coil will age its isolation. Thus, please do not ground connected the coil to reduce electrical erosion if possible. And please provide protection circuit to avoid broken wire and losses.
- 9) Please make sure that there are no silicon-based substances (such as silicon rubber, silicone oil, silicon-based coating agents, silicon fillers, etc.) around the relay, because it will generate silicon-containing volatile gas, which may cause poor contact in case of silicon-containing volatile gas sticking on contact
- 10) About preferable condition of operation, storage and transportation, please refer to "Explanation to terminology and guidelines of relay".
- 11) During the relay pick-up or drop-out processes, there are stages of contact pressure change, contact vibration and unstable contact etc. When the voltage applied to coil is gradually changed, it will lengthen the unstable stage and affect relay endurance. To reduce this influence, please apply step voltage (switching circuit) to relay coil.

### Disclaimer

The specification is for reference only. See to "Terminology and Guidelines" for more information. Specifications subject to change without notice. We could not evaluate all the performance and all the parameters for every possible application. Thus the user should be in a right position to choose the suitable product for their own application. If there is any query, please contact Hongfa for the technical service. However, it is the user's responsibility to determine which product should be used only.

© Xiamen Hongfa Electroacoustic Co., Ltd. All rights of Hongfa are reserved.