

## Si4012 CRYSTAL-LESS FSK/OOK RF TRANSMITTER

### Features

- Frequency range
  - 27–960 MHz
- Output power range
  - –13 to +10 dBm
- Low Power Consumption
  - OOK
    - 14.2 mA @ +10 dBm
  - FSK
    - 19.8 mA @ +10 dBm
- Data rate:
  - Up to 100 kbaud FSK
  - Up to 50 kbaud OOK
- FSK and OOK modulation
- Power supply = 1.8 to 3.6 V
- Automatic antenna tuning
- Programmable ramp rate
- Crystal-less operation
  - ±150 ppm: 0 to 70° C
  - ±250 ppm: –40 to 85° C
  - Optional crystal input for applications requiring tighter tolerances
- Ultra low standby current <10 nA
- Integrated voltage regulator
- 255 byte FIFO
- Low battery detector
- SMBus Interface
- –40 to +85 °C temperature range
- 10-Pin MSOP Package, RoHs compliant
- Low BOM



### Ordering Information:

See page 43.

### Applications

- Wireless MBus T1-mode
- Remote control
- Home security & alarm
- Personal data logging
- Toy control
- Wireless PC peripherals
- Remote meter reading
- Remote keyless entry
- Home automation
- Industrial control
- Sensor networks
- Health monitors

### Description

Silicon Laboratories' Si4012 is a fully-integrated crystalless CMOS high-data-rate RF transmitter designed for the sub-GHz ISM band. This chip is optimized for battery powered applications requiring low standby currents and high output transmit power.

The device offers advanced radio features including continuous frequency coverage from 27–960 MHz, adjustable output power of up to +10 dBm, and data rates up to 100 kbaud in FSK mode. The Si4012's high level of integration offers reduced BOM cost while simplifying overall system design.

### Functional Block Diagram

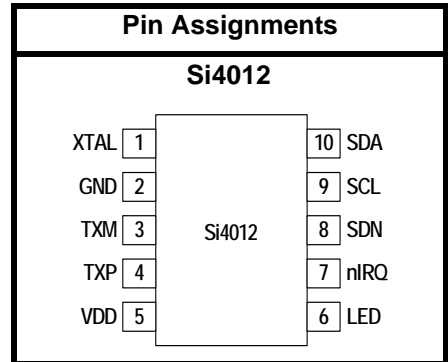
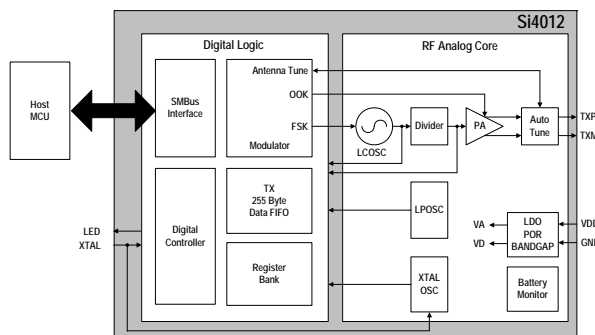

Patents pending



---

**TABLE OF CONTENTS**

---

<b><u>Section</u></b>	<b><u>Page</u></b>
<b>1. Electrical Specifications</b> .....	<b>4</b>
1.1. Definition of Test Conditions .....	7
<b>2. Typical Application Schematic</b> .....	<b>8</b>
<b>3. Functional Description</b> .....	<b>9</b>
<b>4. Host MCU Interface</b> .....	<b>10</b>
4.1. SMBus Interface .....	10
4.2. SMBus Flow Control .....	10
4.3. Host Interrupts .....	10
4.4. Operating Mode Control .....	11
<b>5. Command Structure</b> .....	<b>15</b>
5.1. Commands .....	17
5.2. Properties .....	32
5.3. Error Codes .....	41
<b>6. Pin Descriptions</b> .....	<b>42</b>
<b>7. Ordering Guide</b> .....	<b>43</b>
<b>8. Package Outline</b> .....	<b>44</b>
<b>9. Land Pattern: 10-Pin MSOP</b> .....	<b>45</b>
<b>10. Top Marking: 10-Pin MSOP</b> .....	<b>47</b>
<b>Document Change List</b> .....	<b>48</b>
<b>Contact Information</b> .....	<b>50</b>

## 1. Electrical Specifications

**Table 1. Recommended Operating Conditions<sup>1</sup>**

Parameter	Symbol	Test Condition	Min	Typ	Max	Unit
Supply Voltage	$V_{DD}$		1.8	—	3.6	V
Supply Voltage Slew Rate		Initial Battery Insertion <sup>2</sup>	20	—	650	mV/ us
Input Voltage		Digital Input Signals	-0.3	—	$V_{DD} + 0.3$	V

**Notes:**

- All specifications guaranteed by production test unless otherwise noted. Production test conditions and max limits are listed in "1.1. Definition of Test Conditions" on page 7.
- Recommend bypass capacitor = 1  $\mu$ F; slew rate measured 1 V <  $V_{DD}$  < 1.7 V.

**Table 2. DC Characteristics\***

Parameter	Symbol	Conditions	Min	Typ	Max	Units
Power Saving Modes	$I_{Shutdown}$	Lowest current mode	—	10	—	nA
	$I_{Idle}$	Register values retained, lowest current consumption idle mode	—	600	—	$\mu$ A
TX Mode Current @ 10 dBm	$I_{TX\_OOK}$	OOK, Manchester encoded	—	14.2	—	mA
	$I_{TX\_FSK}$	FSK	—	19.8	—	mA

**\*Note:** All specifications guaranteed by production test unless otherwise noted. Production test conditions and max limits are listed in "1.1. Definition of Test Conditions" on page 7.

**Table 3. Si4012 RF Transmitter Characteristics<sup>1</sup>**

(TA = 25 °C, VDD = 3.3 V, RL = 550 Ω, unless otherwise noted)

Parameter	Test Condition	Min	Typ	Max	Unit
Frequency Range (F <sub>RF</sub> ) <sup>2</sup>		27	—	960	MHz
Frequency Noise (rms) <sup>3</sup>	Allen deviation, measured across 1 ms interval	—	0.3	—	ppm
Phase Noise @ 915 MHz	10 kHz offset	—	-70	—	dBc/Hz
	100 kHz offset	—	-100	—	dBc/Hz
	1 MHz offset	—	-105	—	dBc/Hz
Frequency Tuning Time		—	5	—	ms
Carrier Frequency Accuracy	0 °C ≤ T <sub>A</sub> ≤ 70 °C	-150		+150	ppm
	-40 °C ≤ T <sub>A</sub> ≤ 85 °C	-250		+250	ppm
Frequency Error Contribution with External Crystal		-10	—	+10	ppm
Transmit Power <sup>4</sup>	Maximum programmed Tx power, with optimum differential load, V <sub>DD</sub> > 2.2 V	—	10	—	dBm
	Minimum programmed TX power, with optimum differential load, V <sub>DD</sub> > 2.2 V	—	-13	—	dBm
	Power variation vs temp and supply, with optimum differential load, V <sub>DD</sub> > 2.2 V	-1.0	—	0.5	dB
	Power variation vs temp and supply, with optimum differential load, V <sub>DD</sub> > 1.8 V	-2.5	—	0.5	dB
	Transmit power step size from -13 to 6.5 dBm	—	0.25	—	dB
PA Edge Ramp Rate Programmable Range	OOK mode	0.34	—	10.7	us
Data Rate	OOK	0.1	—	50	kbaud
	FSK	0.1	—	100	kbaud
FSK Deviation	Max frequency deviation	—	275	—	ppm
	Deviation resolution	—	2	—	ppm
	Deviation accuracy	±(4 ppm + 2% pk-pk target FSK deviation in ppm)			ppm
OOK Modulation Depth		60	—	—	dB
Antenna Tuning Capacitive Range (Differential)	315 MHz	2.4	—	12.5	pF

**Notes:**

1. All specifications guaranteed by production test unless otherwise noted. Production test conditions and max limits are listed in "1.1. Definition of Test Conditions" on page 7.
2. The frequency range is continuous over the specified range.
3. The frequency step size is limited by the frequency noise.
4. Optimum differential load is equal to  $4 V / (11.5 \text{ mA} / 2 \times 4 / \text{PI}) = 550 \Omega$ . Therefore the antenna load resistance in parallel with the Si4012 differential output resistance should equal 600 Ω.

**Table 4. Low Battery Detector Characteristics\***

(TA = 25° C, VDD = 3.3 V, RL = 550 Ω, unless otherwise noted)

Parameter	Test Condition	Min	Typ	Max	Unit
Battery Voltage Measurement Accuracy		—	2	—	%

**\*Note:** All specifications guaranteed by production test unless otherwise noted. Production test conditions and max limits are listed in "1.1. Definition of Test Conditions" on page 7.

**Table 5. Optional Crystal Oscillator Characteristics\***

(TA = 25° C, VDD = 3.3 V, RL = 600 Ω, unless otherwise noted)

Parameter	Test Condition	Min	Typ	Max	Unit
Crystal Frequency Range		10	—	13	MHz
Input Capacitance (GPIO0)	GPIO0 configured as a crystal oscillator; XO_LOWCAP=1	—	3	—	pF
	GPIO0 configured as a crystal oscillator; XO_LOWCAP=0	—	5.5	—	pF
Crystal ESR	GPIO0 configured as a crystal oscillator; XO_LOWCAP=1	—	—	120	Ω
	GPIO0 configured as a crystal oscillator; XO_LOWCAP=0	—	—	80	Ω
Start-Up Time	Crystal oscillator only, 60 mH motional arm inductance	—	9	50	ms

**\*Note:** All specifications guaranteed by production test unless otherwise noted. Production test conditions and max limits are listed in "1.1. Definition of Test Conditions" on page 7.

**Table 6. Thermal Conditions**

Parameter	Symbol	Value	Unit
Ambient Temperature	T <sub>A</sub>	−40 to 85	°C
Junction Temperature	T <sub>OP</sub>	−40 to 90	°C
Storage Temperature	T <sub>STG</sub>	−55 to 125	°C

**Table 7. Absolute Maximum Ratings<sup>1,2</sup>**

Parameter	Symbol	Value	Unit
Supply Voltage	V <sub>DD</sub>	−0.5 to 3.9	V
Input Current <sup>3</sup>	I <sub>IN</sub>	10	mA
Input Voltage <sup>4</sup>	V <sub>IN</sub>	−0.3 to (V <sub>DD</sub> + 0.3)	V

**Notes:**

1. Permanent device damage may occur if the absolute maximum ratings are exceeded. Functional operation should be restricted to the conditions as specified in the operational sections of this data sheet. Exposure beyond recommended operating conditions for extended periods may affect device reliability.
2. Handling and assembly of these devices should only be done at ESD-protected workstations.
3. All input pins besides V<sub>DD</sub>.
4. For GPIO pins configured as inputs.

## 1.1. Definition of Test Conditions

### Production Test Conditions:

- $T_A = +25\text{ }^\circ\text{C}$ .
- $V_{DD} = +3.3\text{ VDC}$ .
- TX output power measured at 100 MHz.
- All RF output levels referred to the pins of the Si4012 (not the RF module).

### Qualification Test Conditions:

- $T_A = -40\text{ to }+85\text{ }^\circ\text{C}$ .
- $V_{DD} = +1.8\text{ to }+3.6\text{ VDC}$ .
- All RF output levels referred to the pins of the Si4012 (not the RF module).

# Si4012

## 2. Typical Application Schematic

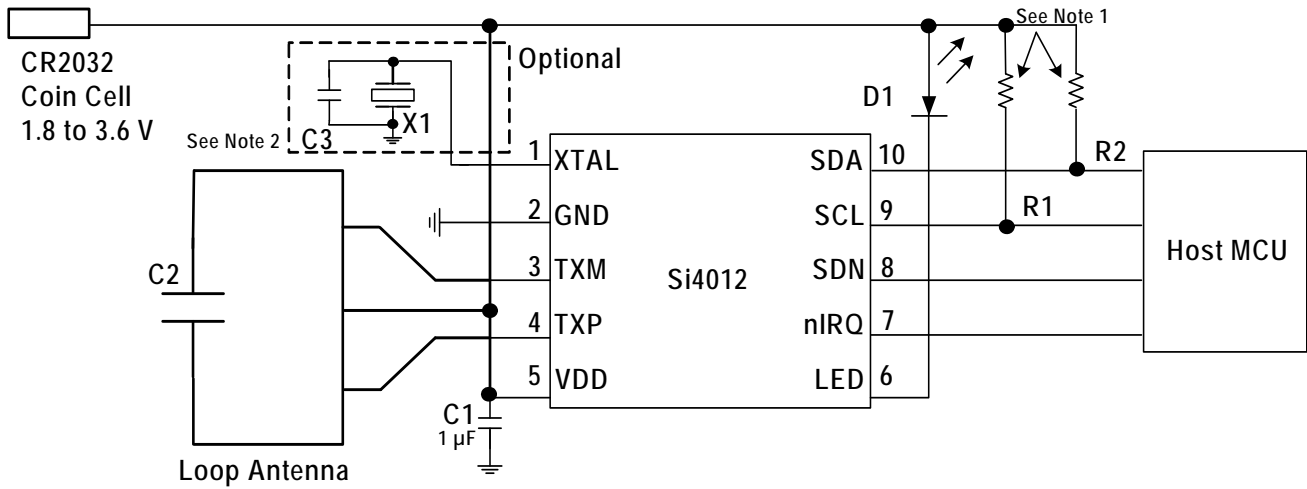

### Notes:

1. The Si4012 has internal 50 kΩ pull-up resistors. Additional optional external pull-up resistors may be added should the board design required it.
2. See note about how to choose the value of C3 in "5.2.10. PROPERTY: XO\_CONFIG" on page 39.

### 3. Functional Description

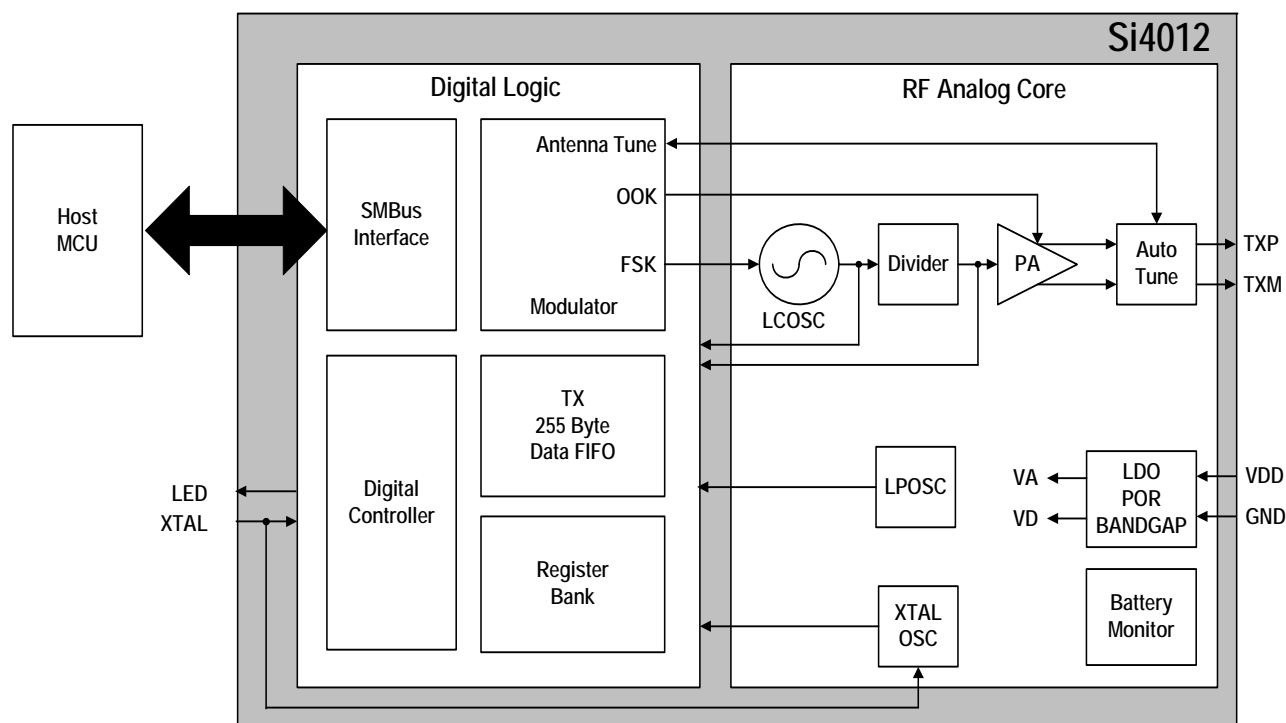

**Figure 1. Si4012 Functional Block Diagram**

The Si4012 is a fully-integrated, crystal-less, sub-GHz CMOS RF transmitter offering industry-leading RF performance, high integration, flexibility, low BOM, small board area, and ease of design.

The device is designed to operate with any host MCU via a serial interface while optimized for battery-powered applications. The Si4012 operates from voltages ranging from 1.8 to 3.6 V and offers an ultra-low standby current consumption of less than 10 nA.

The embedded power amplifier can be programmed to supply from  $-13$  dBm up to  $+10$  dBm, while the patented automatic antenna tuning circuit ensures that the resonant frequency and impedance matching between the PA output and the connected antenna are configured for optimum transmit efficiency and low harmonic content.

Users may configure the device for either FSK or OOK modulation with supported symbol rates of up to 100 kbps. To ensure the lowest system cost, the Si4012 can be used without an external crystal or frequency reference by leveraging Silicon Labs' patented and proven crystal-less oscillator technology. This technology offers better than  $\pm 150$  ppm carrier frequency stability over the temperature range of  $0$  to  $+70$  °C and  $\pm 250$  ppm carrier frequency stability over the industrial temperature range of  $-40$  to  $+85$  °C. No production alignments are necessary since all RF functions are integrated into the device.

## 4. Host MCU Interface

### 4.1. SMBus Interface

The SMBus interface is implemented as a bidirectional 2-wire interface (SCL, SDA) with the host configured as master and the Si4012 configured as slave. Both standard (100 kbps) and fast (400 kbps) modes are supported with 7-bit addressing. The default device address is 1110000x, where x is the R/W bit.

#### 4.1.1. Design Recommendation

In designs with multiple SMBus devices, it is recommended to use separate SMBus buses where possible since all attached SMBus devices will wake on bus traffic to confirm address. This process can lead to better battery life compared to systems with single-bus designs.

### 4.2. SMBus Flow Control

The SCL and SDA pins are configured as open drain requiring external pull-up resistors. Flow control is implemented using the open drain configuration as shown below.

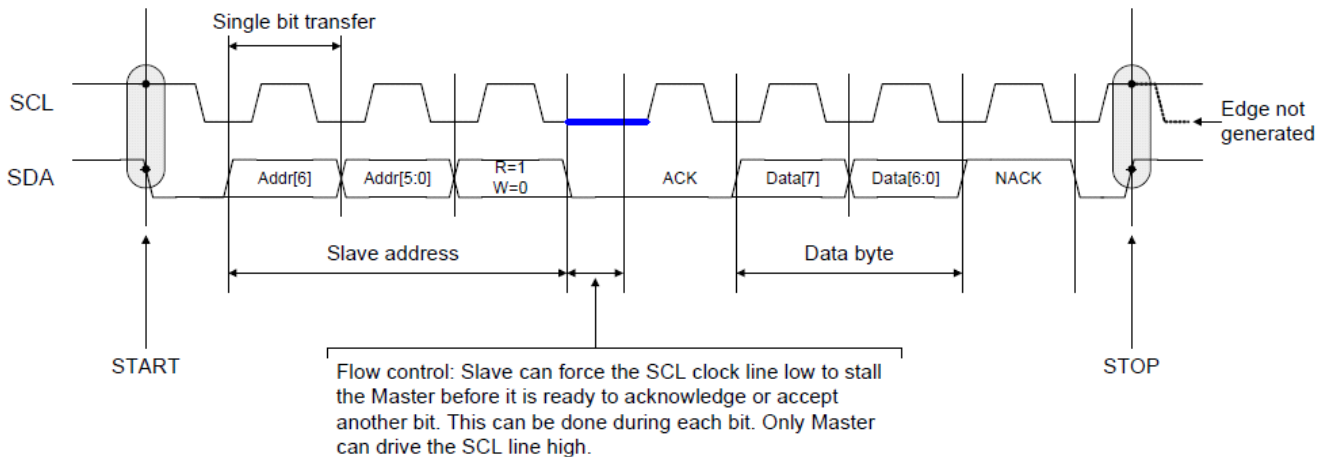

**Figure 2. WRITE Operation from Master to Slave**

The data (SDA) pin never changes when SCL = 1 during bit data transfers. If it changes, it indicates a START or STOP condition generated by the master/host. After the START condition, a 7-bit address is sent to the Si4012/slave by the host/master, followed by a single bit determining what is going to drive SDA (i.e., a write or read operation). For a WRITE operation, the master drives the following SDA bits, and the slave sends ACK/NAK bits. For a READ operation, the slave drives the data bits, and the master responds with ACK/NACK.

Figure 2 shows a write operation from MASTER to SLAVE. Shortly after the R/W bit is received, the SLAVE device holds the SCL line low (blue line), thus stalling the master. The master will detect when SCL is released by the slave and will clock in the ACK/NACK bit from the slave (ACK shown above). By this, the slave (Si4012) can service each incoming byte and manage flow control to the host.

### 4.3. Host Interrupts

An nIRQ line from the Si4012 to the host is used to issue interrupts to the host. The host can then read the interrupt status and clear interrupts from the Si4012 via the SMBus interface.

## 4.4. Operating Mode Control

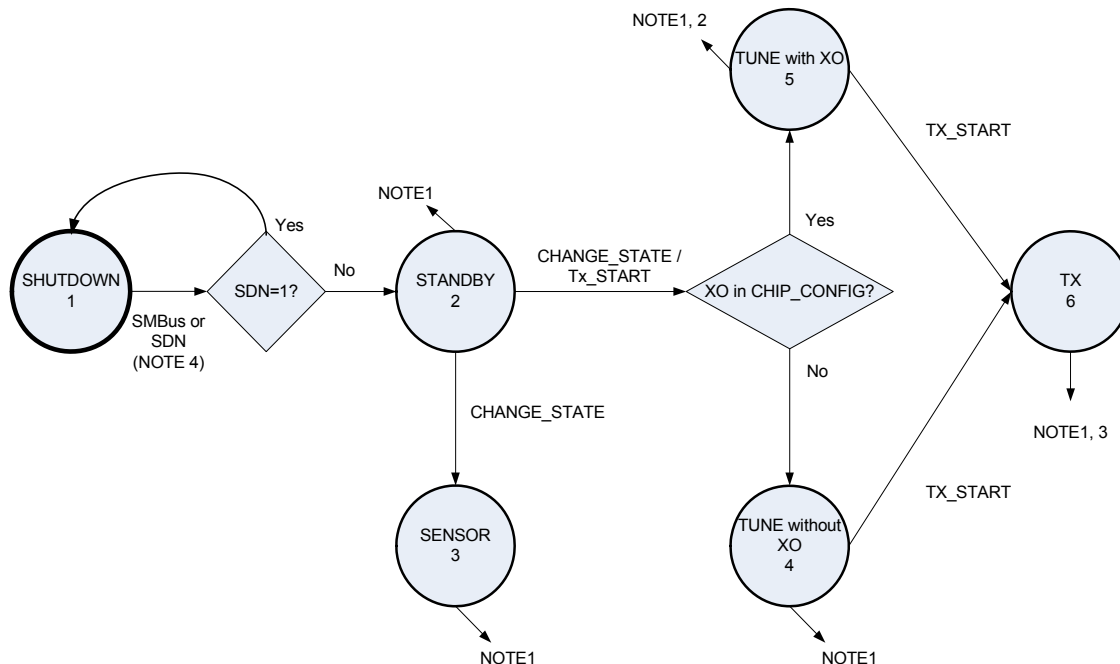

**Figure 3. State Machine Diagram**

### Transition Notes

1. Transition to any state (including SHUTDOWN) using the CHANGE\_STATE command. Alternatively, transition to SHUTDOWN using the SDN pin.
2. If a CHANGE\_STATE command to the XO TUNE state is issued (even if already in the XO TUNE state), then an XO TUNE operation is carried out immediately. This enables close control of timing (fastest execution) for a subsequent TX\_START command. In the TUNE state, a tune operation is carried out in the interval specified in TUNE\_INTERVAL.
3. Transition to end state specified in the TX\_START command or TX\_STOP command.
4. If coming out of the SHUTDOWN via SMBus, an SMBus “wake-up” byte is required. This byte is discarded, and normal SMBus communication can proceed after the power on reset (ipor) is asserted to the host.

### State Descriptions

The Si4012 has six power modes, which are summarized below. Further details on the IC configuration in these modes can be found in "5.1.5. COMMAND: CHANGE\_STATE" on page 22.

- **SHUTDOWN**—Lowest current consumption; the majority of hardware blocks are powered down.
- **STANDBY**—Low power state with fast SMBus response.
- **SENSOR**—Same as STANDBY, but the battery is measured periodically.
- **TUNE**—Periodic tuning state. A tune is performed on any CHANGE\_STATE to TUNE command and then periodically based on the interval defined in TUNE\_INTERVAL. This provides faster transition to TX. If XO is enabled, XO will be used during tune operation.
- **TX**—Transmission state.

Table 8. Power Modes

Mode	Circuit Blocks								I <sub>VDD</sub>	Response Time to TX (without XO)	Response Time to TX (with XO Early Enable)
	Digital LDO	SMBUS	SYS CLK	LBD	LC	XTAL	DIV	PA			
Shut-down	OFF	OFF	OFF	OFF	OFF	OFF	OFF	OFF	10 nA	22.2 ms	22.2 ms
Standby	ON	ON	SLOW	OFF	OFF	OFF	OFF	OFF	600 $\mu\text{A}^3$	6.6 ms	6.6 ms <sup>4</sup>
Sensor		ON	FAST	ON	OFF	OFF	OFF	OFF	610 $\mu\text{A}^3$	6.6 ms	6.6 ms <sup>4</sup>
Tune without XO		ON	FAST	OFF	ON <sup>1</sup>	OFF	ON <sup>1</sup>	ON <sup>1</sup>	Note <sup>2</sup>	370 $\mu\text{s}$	—
Tune with XO		ON	FAST	OFF	ON <sup>1</sup>	ON	ON <sup>1</sup>	ON <sup>1</sup>	Note <sup>2</sup>	—	370 $\mu\text{s}$

**Notes:**

1. The LC, DIV, and PA are turned on as needed during the Tune operation.
2. See the tune section from Tune Start to PA Tune in the charts below for current consumption in Tune with XO and Tune without XO.
3. The current consumption at Standby and Sensor does not include the power consumed by the internal XO circuitry. XO should be turned off with SET\_PROPERTY/CHIP\_CONFIG to save power if external XO is not used or if tuning is not happening soon when external XO is present.
4. The response time assumes external XO stays enabled prior to TX.

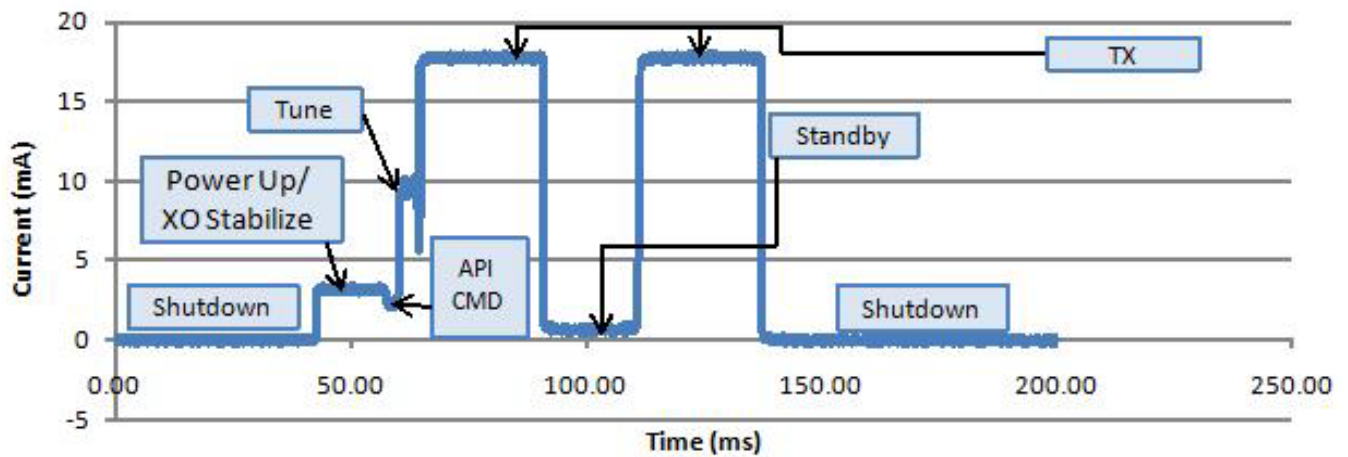

Figure 4. Current Consumption with XO

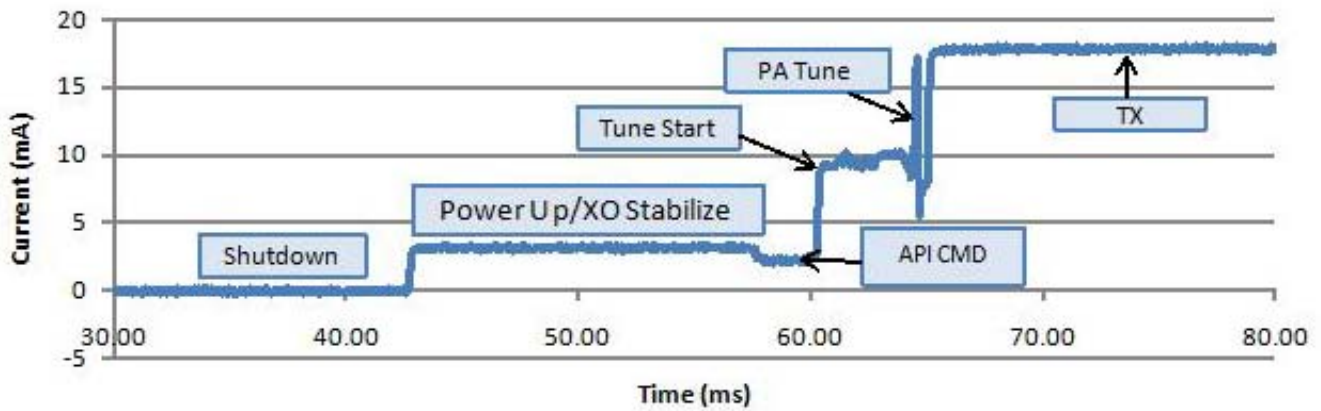

Figure 5. Current Consumption with XO (Upscaled between 30 and 80 ms)

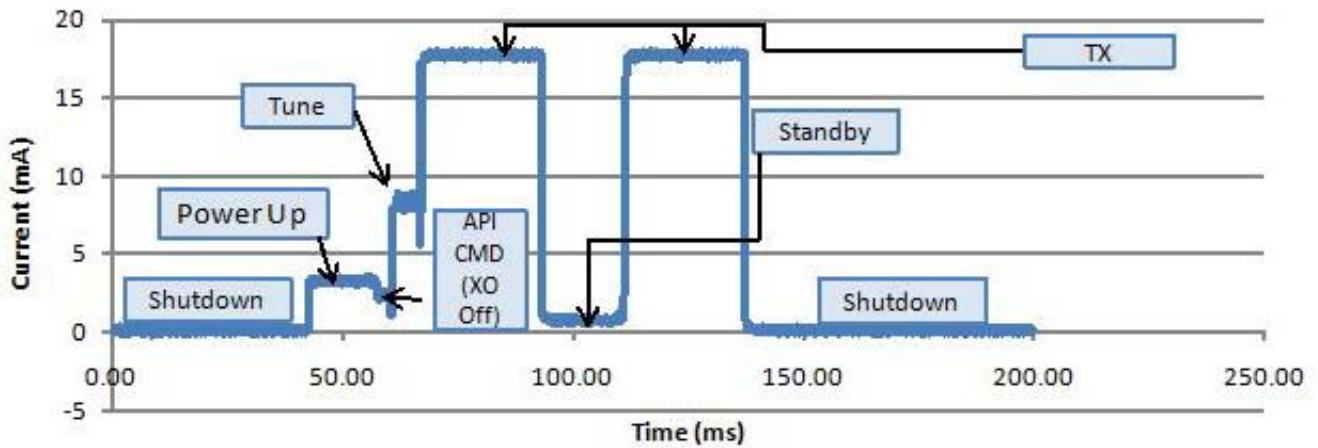

Figure 6. Current Consumption without XO

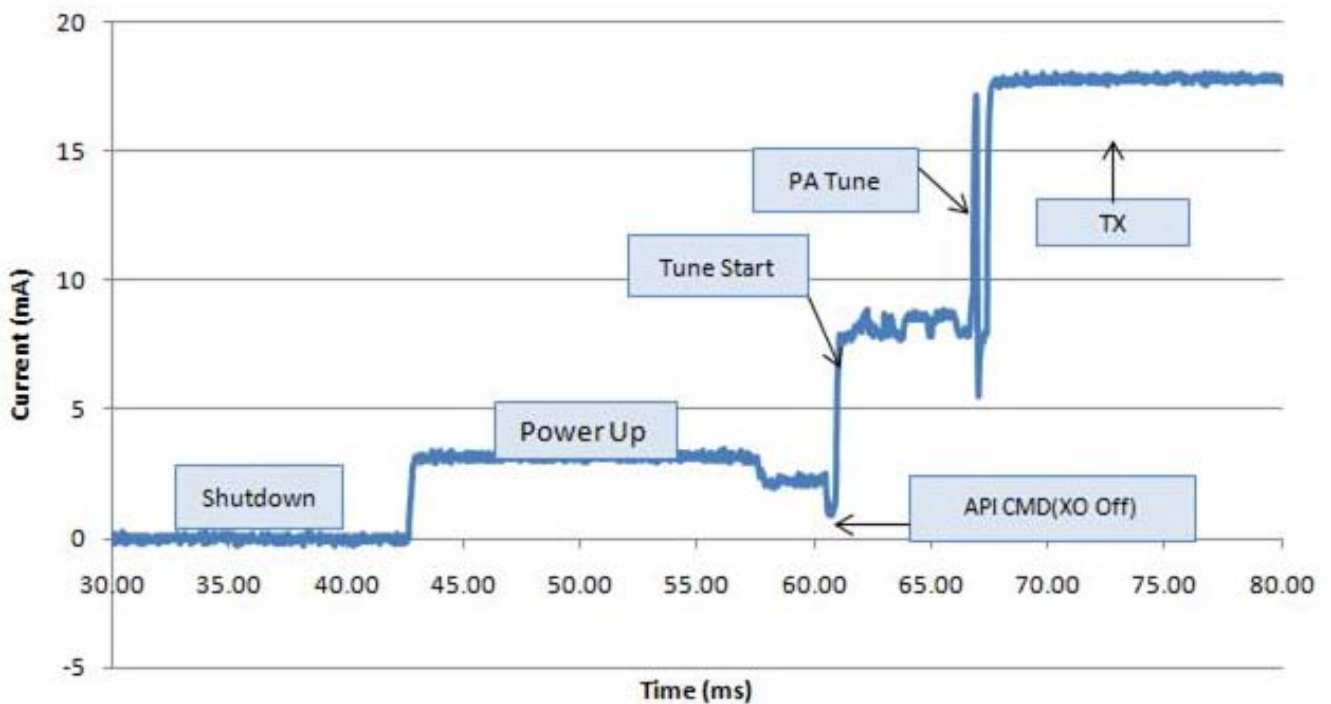

Figure 7. Current Consumption without XO (Upscaled between 30 and 80 ms)

## 5. Command Structure

The Si4012 has been designed to complete commands in the shortest time possible and to support both polled or event driven (interrupt based) modes. For longer operations, commands are implemented as launch commands. When the result of the launched command is completed, status is returned to the host via host polling or as an interrupt (if enabled). The status is obtained over the SMBus.

For example, when a TX\_START command is launched, the Si4012 will parse the command, check it for errors, and return the status to the host immediately; it will also start the TX process. The host can then either poll for an error or “packet sent” or receive an interrupt on nIRQ.

All host commands consist of a 1-byte opcode followed by 0 or more arguments. All responses from the Si4012 consist of a 1-byte top level status followed by 0 or more data values.

### Command Structure:

Bit	7	6	5	4	3	2	1	0
CMD								
ARG1								
ARG2								
...								
ARGn								

### Response Structure:

Bit	7	6	5	4	3	2	1	0
STATUS	CTS	Err[6:0]						
DATA1								
DATA2								
...								
DATAn								

A CTS (Clear to Send) indicates that the Si4012 has received the command and that the host can send another command. The CTS does not necessarily mean the command has been processed. The host should poll interrupt status or use interrupts (nIRQ) to get execution status for deferred operations.

Err[6:0] indicates an error has occurred if it is non-zero. See the “error codes” section for a full list of available error codes.

## GET\_INT\_STATUS Command

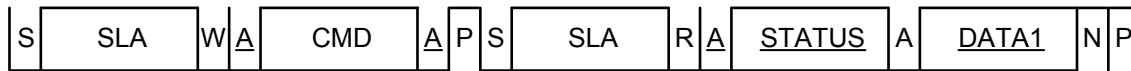

## TX\_STOP Command

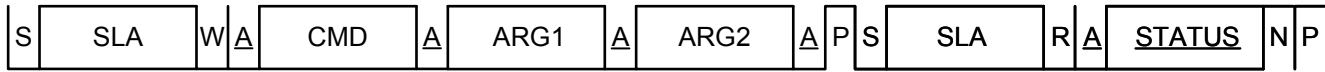

Underlined items are sent from the Si4012 (slave)

S = Start  
W = Write (1bit)  
R = Read (1bit)  
A = Acknowledge  
N = Not-Acknowledge  
P = Stop

SLA = Slave Address (7 bits)  
CMD = Command opcode (8bit)  
ARG = Command Argument (8bit)  
DATA = Data Value (8bit)  
STATUS = Top Level Status (8bit)

### Figure 8. SMBus Sequence Example

Figure 8 above demonstrates two examples using the SMBus command sequence.

## 5.1. Commands

Table 9 lists the commands available via the SMBus and described in the following sections.

**Table 9. Commands Available via SMBus**

Section	Command	Description
5.1.1	Get_Rev	Device revision information
5.1.2	Set_Property	Sets device properties
5.1.3	Get_Property	Gets device properties
5.1.4	LED_CTRL	LED Control
5.1.5	Change_State	Configures device mode
5.1.6	Get_State	Get device mode
5.1.7	TX_Start	Start data transmission
5.1.8	Set_Int	Enable interrupts
5.1.9	Get_Int_Status	Read & clear interrupts
5.1.10	Init_FIFO	Clears Tx FIFO
5.1.11	Set_FIFO	Stores data in FIFO for Tx
5.1.12	TX_Stop	Stops transmission
5.1.13	Get_Bat_Status	Gets battery status

# Si4012

---

## 5.1.1. COMMAND: GET\_REV

**Purpose:** Return product and revision information for the device.

**ARG:** None

**DATA:** Product ID, Revision ID.

**Command:**

<b>GET_REV Command</b>	<b>7</b>	<b>6</b>	<b>5</b>	<b>4</b>	<b>3</b>	<b>2</b>	<b>1</b>	<b>0</b>
CMD	0x10							

**Response:**

<b>GET_REV Reply</b>	<b>7</b>	<b>6</b>	<b>5</b>	<b>4</b>	<b>3</b>	<b>2</b>	<b>1</b>	<b>0</b>
STATUS	CTS	Err						
DATA1	ProdId[31:24]							
DATA2	ProdId[23:16]							
DATA3	ProdId[15:8]							
DATA4	ProdId[7:0]							
DATA5	RevisionID_RMIDU[47:40]							
DATA6	RevisionID_RMIDU[39:32]							
DATA7	RevisionID_RMIDL[31:24]							
DATA8	RevisionID_RVID[23:16]							
DATA9	RevisionID_FWIDU[15:8]							
DATA10	RevisionID_FWIDL[7:0]							

## 5.1.2. COMMAND: SET\_PROPERTY

- Purpose:** Set a property common to one or more commands. These are similar to parameters for a command but are not expected to change frequently and may be controlled by the higher software layers. Setting properties may not cause the device to take immediate action, however the property will take effect once a command which uses it is issued. See the “Properties” section of this document for details on properties.
- ARG:** PROP\_ID[7:0]— Selects the property to set.  
DATA[n:0]—Value of the property. The length varies depending on the PROP\_ID, up to 6-byte in big Endian can be specified.
- DATA:** None
- Command:**

SET_PROPERTY Command	7	6	5	4	3	2	1	0
CMD	0x11							
ARG1	PROP_ID[7:0]							
ARG2	PROP_DATA1, MSB of Property 's value							
ARG3	PROP_DATA 2							
ARG4	PROP_DATA 3							
ARG5	PROP_DATA 4							
ARG6	PROP_DATA5							
ARG7	PROP_DATA6							

**Response:**

SET_PROPERTY Reply	7	6	5	4	3	2	1	0
STATUS	CTS	Err						

## 5.1.3. COMMAND: GET\_PROPERTY

**Purpose:** Return the value of a specified property. See "5.2. Properties" on page 32 for details on properties.

**ARG:** PROP\_ID[7:0]—Selects the property to retrieve.

**DATA:** DATA[n:0] —Value of the specified property, the length varies depending on the PROP\_ID, up to 6 bytes

**Command:**

GET_PROPERTY Command	7	6	5	4	3	2	1	0
CMD	0x12							
ARG1	PROP_ID[7:0]							

**Response:**

GET_PROPERTY Reply	7	6	5	4	3	2	1	0
STATUS	CTS	Err						
DATA1	PROP_DATA1, MSB of Property's value							
DATA2	PROP_DATA 2							
DATA3	PROP_DATA 3							
DATA4	PROP_DATA 4							
DATA5	PROP_DATA5							
DATA6	PROP_DATA6							

## 5.1.4. COMMAND: LED\_CTRL

**Purpose:** Turn on/off LED if LED driver is enabled.

**ARG:** LedOn—If LED driver is enabled, turn LED on if set, otherwise, turn LED off. If LED driver is not enabled, LedOn is ignored if set.

**DATA:** None

**Command:**

LED_CTRL Command	7	6	5	4	3	2	1	0
CMD	0x13							
ARG1								LedOn

**Response:**

LED_CTRL Reply	7	6	5	4	3	2	1	0
STATUS	CTS	Err						

**Notes:** If LEDOn is set, the Si4012 checks the LedIntensity setting set by the host in SET\_PROPERTY/LED\_INTENSITY. If the LedIntensity is 0, LED driver will be disabled. Err is set to 0x0A to report this condition.

## 5.1.5. COMMAND: CHANGE\_STATE

**Purpose:** Change state to IDLE or SHUTDOWN. The device will change to the specified state at the earliest time possible. If changing into IDLE state, ARG2 specifies the idle mode.

**Table 10.**

Mode	Circuit Blocks								I <sub>VDD</sub>	Response Time to TX (without XO)	Response Time to TX (with XO Early Enable)
	Digital LDO	SMBUS	SYS CLK	LBD	LC	XTAL	DIV	PA			
Shut-down	OFF	OFF	OFF	OFF	OFF	OFF	OFF	OFF	15 nA	22.2 ms	22.2 ms
Standby	ON	ON	SLOW	OFF	OFF	OFF	OFF	OFF	600 $\mu$ A <sup>3</sup>	6.6 ms	6.6 ms <sup>4</sup>
Sensor		ON	FAST	ON	OFF	OFF	OFF	OFF	610 $\mu$ A <sup>3</sup>	6.6 ms	6.6 ms <sup>4</sup>
Tune without XO		ON	FAST	OFF	ON <sup>1</sup>	OFF	ON <sup>1</sup>	ON <sup>1</sup>	Note <sup>2</sup>	370 $\mu$ s	—
Tune with XO		ON	FAST	OFF	ON <sup>1</sup>	ON	ON <sup>1</sup>	ON <sup>1</sup>	Note <sup>2</sup>	—	370 $\mu$ s

**Notes:**

1. The LC, DIV and PA are turned on as needed during the Tune operation.
2. See the tune section from Tune Start to PA Tune in the charts below for current consumption in Tune with XO and Tune without XO.
3. The current consumption at Standby and Sensor does not include the power consumed by the internal XO circuitry. XO should be turned off with SET\_PROPERTY/CHIP\_CONFIG to save power if external XO is not used or if tuning is not happening soon when external XO is present.
4. The response time assumes external XO stays enabled prior to TX.

**ARG:**

- State[1:0]—state to transition to.
  - 00 IDLE – Go to idle mode state using the idle mode specified.
  - 01 SHUTDOWN – Go to shutdown state.
  - 10–11 – Reserved.
- IdleMode[2:0]—IDLE mode if changing to idle state.
  - 000 Standby – Low Power State
  - 001 Sensor – Enable Low Battery Detector
  - 010 Tune – Periodic tuning
  - 011–111 – Reserved

**DATA:** None

**Command:**

CHANGE_STATE Command	7	6	5	4	3	2	1	0
CMD	0x60							
ARG1							State[1:0]	
ARG2							IdleMode[2:0]	

**Response:** None if changing to SHUTDOWN, otherwise

CHANGE_STATE Reply	7	6	5	4	3	2	1	0
STATUS	CTS	Err						

**Notes:**

1. Changing state among different idle modes is allowed.
2. State can also be changed via TX\_START/TX\_STOP.
3. An alternative way to transition to SHUTDOWN is by setting SDN pin to high.
4. SMBus activity or setting SDN pin to low will take the device out of shut down state.

## 5.1.6. COMMAND: GET\_STATE

**Purpose:** Get chip state and status.

**ARG:** None

**DATA:**

- State[1:0]—current state
  - 00 Idle
  - 01 Reserved
  - 10 TX
- AutoTX—current AutoTX setting
- IdleMode[2:0]. If State is Idle
  - 000 Standby – Low power state
  - 001 Sensor – Enable Low Battery Detector
  - 010 Tune – Periodic tuning
- DTMod[1:0] if State is TX
  - 00 – FIFO Mode
  - 01 – CW Mode
  - 10 – PN9-0 Mode
  - 11 – PN9-1 Mode
- ActTxPktSize—actual packet sent in the last transmission
- PrevError —error code if error occurred in the previous operation

**Command:**

GET_STATE Command	7	6	5	4	3	2	1	0
CMD	0x61							

**Response:**

GET_STATE	7	6	5	4	3	2	1	0
STATUS	CTS	Err						
DATA1						AutoTX	State[1:0]	
DATA2						IdleMode[2:0]/DTMod[1:0]		
DATA3	ActTxPktSize[15:8]							
DATA4	ActTxPktSize[7:0]							
DATA5	PrevError							

## 5.1.7. COMMAND: TX\_START

**Purpose:** Start transmission and go to a designated state after the packet is transmitted. This is an asynchronous operation. Transmission may not have been started when response is sent back the host.

**ARG:**

- Packet Size[15:0] to be transmitted
- State to transition to when transmission is completed.
- AutoTX—Enable/Disable FIFO Auto-TX
  - 1: Auto-Transmit Enabled.  
Transmission will start when the FIFO level reaches the auto transmit threshold specified in ffautotxthr in FIFO\_THRESHOLD. If ffautotxthr=0, transmission will start immediately.
  - 0:Auto-Transmit Disabled.  
Transmit will start immediately until the data specified in the PacketSize is transmitted, or all the data in the FIFO is exhausted, whichever occurs first. If the FIFO becomes empty before the specified packet length is transmitted a FIFO underflow error will occur.
- State[1:0]—State to transition to when transmission is completed.
  - 00: IDLE—Go to idle state when the packet transmission completes based on the idle mode.
  - 01: SHUTDOWN—Go to shutdown state when the packet transmission completes.
  - 10–11: Reserved.
- IdleMode[2:0] if State is Idle; DTmod[1:0] if State is TX.
 

Idle Mode	000	Standby	– Low power state
	001	Sensor	– Enable Low Battery Detector
	010	Tune	– Periodic tuning
- DTMod[1:0]
 

00	– FIFO Mode
01	– CW Mode
10	– PN9-0 Mode
11	– PN9-1 Mode

**DATA:** Current data size in the FIFO when TX\_START is received.

**Command:**

TX_START Command	7	6	5	4	3	2	1	0
CMD	0x62							
ARG1	PacketSize[15:8]							
ARG2	PacketSize[7:0]							
ARG3						AutoTX	State[1:0]	
ARG4						IdleMode[2:0]		
ARG5	DTMod[1:0]							

# Si4012

---

## Response:

<b>TX_START Reply</b>	<b>7</b>	<b>6</b>	<b>5</b>	<b>4</b>	<b>3</b>	<b>2</b>	<b>1</b>	<b>0</b>
STATUS	CTS	Err						
DATA1	ActualDataSize[7:0]							

## Notes:

Si4012 allows larger packet sizes than the FIFO. It also allows the packet size to be greater than the data available in the FIFO.

- If the packet size is less than the data stored in the FIFO, the data specified in packet size will be transmitted in one transmission leaving leftover data in the FIFO. The size to be transmitted will be specified in the DATA field.
- If the packet size is larger than the data stored in the FIFO size, when TX\_START is received, all the data in the FIFO will be transmitted. The size of the data currently available in the FIFO will be specified in the DATA field. If auto transmit is enabled, the Si4012 will automatically transmit data when the TX FIFO level reaches the auto transmit level dictated by ffautotxthr without another explicit TX\_START until the data specified in PacketSize is all transmitted. An interrupt is triggered with pksent set in the interrupt status. AutoTX state will be cleared when packet is successfully transmitted or FIFO underflow has happened. If auto transmit is not enabled, the Si4012 will start transmitting what's available in the FIFO until FIFO becomes empty. The host is responsible for keeping FIFO from underflow by supplying the balance of the data needed for the packet size.
- If the packet size equals to the data stored in the FIFO size, all the data in the FIFO will be transmitted, ActualDataSize will be equal to the packet size.

The host should poll ipksent using GET\_INT\_STATUS to check when the packet has been sent, or monitor the pksent interrupt.

## 5.1.8. COMMAND: SET\_INT

**Purpose:** Enable interrupts.

**ARG:**

- enffunder—Enable FIFO Underflow
- entxffafull—Enable TX FIFO Almost Full
- entxffaem—Enable TX FIFO Almost Empty
- enffover—Enable FIFO Overflow
- enpksent—Enable Packet Sent
- enlbd—Enable Low Battery Detect

**DATA:** None

**Command:**

<b>SET_INT Command</b>	<b>7</b>	<b>6</b>	<b>5</b>	<b>4</b>	<b>3</b>	<b>2</b>	<b>1</b>	<b>0</b>
CMD	0x63							
ARG1	enffunder	entxffafull	entxffaem	enffover	enpksent	enlbd	entune	reserved

**Response:**

<b>SET_INT Reply</b>	<b>7</b>	<b>6</b>	<b>5</b>	<b>4</b>	<b>3</b>	<b>2</b>	<b>1</b>	<b>0</b>
STATUS	CTS	Err						

## 5.1.9. COMMAND: GET\_INT\_STATUS

**Purpose:** Read the interrupt status and clear interrupts.

**ARG:** None

**DATA:**

- iffunder—FIFO Underflow
- itxffafull—TX FIFO Almost Full
- itxffaem—TX FIFO Almost Empty
- iffover—FIFO Overflow
- ipksent—Packet Sent
- ilbd—Low Battery Detect
- itune—tune complete
- ipor—Power On Reset

**Command:**

<b>GET_INT_STATUS Command</b>	<b>7</b>	<b>6</b>	<b>5</b>	<b>4</b>	<b>3</b>	<b>2</b>	<b>1</b>	<b>0</b>
CMD	0x64							

**Response:**

<b>GET_INT_STATUS Reply</b>	<b>7</b>	<b>6</b>	<b>5</b>	<b>4</b>	<b>3</b>	<b>2</b>	<b>1</b>	<b>0</b>
STATUS	CTS	Err						
DATA1	iffunder	itxffafull	itxf- faem	iffover	ipksent	ilbd	itune	ipor

**Notes:** Calling the GET\_INT\_STATUS command will clear all interrupts and reset the nIRQ pin. Therefore, the host must note any interrupt bits that are set and take the necessary actions to service these interrupts.

### **TX FIFO Almost Full and TX FIFO Almost Empty Interrupts**

These interrupts are triggered upon transition at the respective thresholds. Therefore, if an interrupt is generated for FIFO Almost Empty and then cleared by a call to GET\_INT\_STATUS, another interrupt will NOT be generated if the FIFO remains below the Almost Empty threshold. The FIFO must go above the threshold and then fall back to the threshold before another Almost Empty threshold is generated and sent to the host.

### **Low Battery Detect (LBD) Interrupt**

The LBD is cleared when the host calls GET\_INT\_STATUS. The Si4012 regenerates lbd interrupts periodically when the LBD timer expires.

**5.1.10. COMMAND: INIT\_FIFO****Purpose:** Clear the TX FIFO by clearing the FIFO with 0s and initializing the FIFO head and tail pointer**ARG:** None**DATA:** None**Command:**

<b>INIT_FIFO Command</b>	<b>7</b>	<b>6</b>	<b>5</b>	<b>4</b>	<b>3</b>	<b>2</b>	<b>1</b>	<b>0</b>
CMD	0x65							

**Response:**

<b>INIT_FIFO Reply</b>	<b>7</b>	<b>6</b>	<b>5</b>	<b>4</b>	<b>3</b>	<b>2</b>	<b>1</b>	<b>0</b>
STATUS	CTS	Err						

**5.1.11. COMMAND: SET\_FIFO****Purpose:** Store data from the command interface into FIFO for transmission.**ARG:** Up to 255 bytes**DATA:** None**Command:**

<b>SET_FIFO Command</b>	<b>7</b>	<b>6</b>	<b>5</b>	<b>4</b>	<b>3</b>	<b>2</b>	<b>1</b>	<b>0</b>
CMD	0x66							
ARG1	FIFO_DATA1[7:0]							
ARG2	FIFO_DATA2[7:0]							
...								
ARGn	FIFO_DATA <sub>n</sub> [7:0]							

**Response:**

<b>SET_FIFO Reply</b>	<b>7</b>	<b>6</b>	<b>5</b>	<b>4</b>	<b>3</b>	<b>2</b>	<b>1</b>	<b>0</b>
STATUS	CTS	Err						

If ARG exceeds the FIFO size of 255 bytes, Err is set to 0x08 (Too many arguments).

The Si4012 raises the 'FIFO Almost Full' or 'FIFO Almost Empty' interrupt when appropriate. If auto transmit is enabled and the FIFO level is above the auto transmit threshold, the Si4012 will start transmit automatically.

## 5.1.12. COMMAND: TX\_STOP

**Purpose:** Stop transmission and go to designated state (this command can also be used to abort existing transmissions)

**ARG:**

- State[1:0]—State to transition to when transmission is stopped.
  - 00 IDLE – Go to idle state when the packet transmission is stopped based on the idle mode.
  - 01 SHUTDOWN – Go to shutdown state when the packet transmission is stopped.
  - 10-11 – Reserved.
  
- IdleMode[2:0] —IDLE mode if changing to idle state.
  - 000 Standby – Low power state
  - 001 Sensor – Enable Low Battery Detector
  - 010 Tune – Periodic tuning
  - 011–111 – Reserved

**DATA:** None

**Command:**

TX_STOP Command	7	6	5	4	3	2	1	0
CMD	0x67							
ARG1							State[1:0]	
ARG2							IdleMode[2:0]	

**Response:** None if changing to SHUTDOWN, otherwise

TX_STOP Reply	7	6	5	4	3	2	1	0
STATUS	CTS	Err						

## 5.1.13. COMMAND: GET\_BAT\_STATUS

**Purpose:** Get the battery status such as current VDD voltage.

**ARG:** Load Option—0: Battery voltage is measured immediately without any load.

>0: battery voltage is measured after major power hungry parts of the device are temporarily turned on. These parts are turned off when measurement is done after LoadWaitTime x 17  $\mu$ s of wait time.

**DATA:** BTV[15:0]—Battery voltage in mV

**Command:**

GET_BAT_STATUS Command	7	6	5	4	3	2	1	0
CMD	0x68							
ARG	Load/Wait Time							

**Response:**

GET_BAT_STATUS Reply	7	6	5	4	3	2	1	0
STATUS	CTS	Err						
DATA1	BTV[15:8]							
DATA2	BTV[7:0]							

**Notes:**

1. If tuning is in progress when this API is received, Err is set to 0x11 (Device busy).
2. In sensor mode, Si4012 reads battery voltage periodically with no load based on the interval set in SET\_PROPERTY/LBD\_CONFIG.

## 5.2. Properties

### 5.2.1. Properties Summary

Section	Property ID	Property	Description
5.2.2	0x10	CHIP_CONFIG	FSK Dev polarity, LSB first, XO
5.2.3	0x11	LED_INTENSITY	LED current drive strength
5.2.4	0x20	MODULATION_FSKDEV	MOD type and FSK deviation if FSK
5.2.5	0x21	TUNE_INTERVAL	Tuning interval in seconds
5.2.6	0x30	FIFO_THRESHOLD	FIFO almost full, almost empty and auto transmit threshold
5.2.7	0x31	BITRATE_CONFIG	Data rate and ramp rate if OOK
5.2.8	0x40	TX_FREQ	Carrier frequency for transmission if OOK, upper frequency for transmission if FSK
5.2.9	0x41	LBD_CONFIG	Low battery voltage threshold that triggers interrupt, battery voltage sampling interval
5.2.10	0x50	XO_CONFIG	XO frequency and low capacitance control
5.2.11	0x60	PA_CONFIG	PA maximum current driver, PA level, cap, alpha and beta steps

The format table in this section applies to the ARG field of SET\_PROPERTY after PROP\_ID and DATA field of GET\_PROPERTY. I.e., PROP\_ID corresponds to ARG1, PROP\_DATA1 corresponds to ARG2 or DATA1, PROP\_DATA2 corresponds to ARG3 or DATA 2, etc.

Default is the value of a property the Si4012 defaults to if the host does not set the property via SET\_PROPERTY. Fields correspond to the PROP\_DATA.

**5.2.2. PROPERTY: CHIP\_CONFIG****Purpose:** Select FSK deviation polarity, LSB first and external crystal.**Property:** 0x10**Default:** 0x08**Fields:**

- FskDevPola—FSK deviation polarity.
  - 0: +deviation when modulation data is 1 and –dev for Din = 0
  - 1: +dev for Din = 0 and –dev for Din = 1
- LsbFirst—When set, LSB is transmitted first. Otherwise, MSB is transmitted first.
- UseXo—Use external crystal if set

**Format:**

CHIP_CONFIG Property	7	6	5	4	3	2	1	0
PROP_ID	0x10							
PROP_DATA1					UseXo	LsbFirst		FskDevPola

**Note:** If the crystal is not populated on the board, there will still be a 1.4 mA current draw penalty for the XO circuitry on the Si4012. The host should send SET\_PROPERTY/CHIP\_CONFIG with bit 3 cleared to turn off the XO circuitry.

## 5.2.3. PROPERTY: LED\_INTENSITY

- Purpose:** LED current drive strength  
**Property:** 0x11  
**Default:** 0x00  
**Fields:** LedIntensity [1:0]—LED intensity
- 00: LED off
  - 01: 0.37 mA
  - 10: 0.60 mA
  - 11: 0.97 mA.
- Format:**

LED_INTENSITY Property	7	6	5	4	3	2	1	0
PROP_ID	0x11							
PROP_DATA1							LedIntensity[1:0]	

## 5.2.4. PROPERTY: MODULATION\_FSKDEV

- Purpose:** Modulation type and FSK deviation.  
**Property:** 0x20  
**Default:** 0x013F  
**Fields:**
- modutype—Modulation type, default 1.
    - 0: OOK
    - 1: FSK
  - biFskDev[6:0] –biFSKDev if FSK, default 63.

**Format:**

MODULATION_FSKDEV Property	7	6	5	4	3	2	1	0
PROP_ID	0x20							
PROP_DATA1								ModuType
PROP_DATA2		biFskDev[6:0]						

**Note:** If SET\_PROPERTY\DATA\_RATE is sent and data rate is set to a value above 500, but modulation is set to OOK, Err will be set in the response with 'Data rate out of range' error code. The biFSKDev parameter is attained either via the WDS Chip Configurator utility or by using the Si4012 calculation spreadsheet.

### 5.2.5. PROPERTY: TUNE\_INTERVAL

**Purpose:** Tune interval used for periodic tuning.

**Property:** 0x21

**Default:** 0x000A

**Fields:**

- Tuningltv[15:0]—tuning interval in seconds

**Format:**

TUNE_INTERVAL Property	7	6	5	4	3	2	1	0
PROP_ID	0x21							
PROP_DATA1	Tuningltv[15:8]							
PROP_DATA2	Tuningltv[7:0]							

**Note:** The tuning interval specifies the frequency in which the device performs periodic tuning in tune state and in CW Mode. In CW or PN9 mode, if Tuningltv is 0, no tuning will be performed. In FIFO mode, if Si4012 is in tune state but Tuningltv is set to 0 by the host, tuning will be performed every 10 seconds.

### 5.2.6. PROPERTY: FIFO\_THRESHOLD

**Purpose:** FIFO threshold settings—FIFO Almost Empty, FIFO Almost Full and auto transmit level.

**Property:** 0x30

**Fields:**

- ffafullthr[7:0]—FIFO Almost Full Threshold in bytes, default 0xF0
- ffaemthr[7:0]—FIFO Almost Empty Threshold in bytes, default 0x10
- ffautotxthr[7:0]—FIFO Threshold controlling when to start auto transmit, default 0x20 bytes.

**Format:**

FIFO_THRESHOLD Property	7	6	5	4	3	2	1	0
PROP_HI	0x30							
PROP_DATA1	ffafullthr[7:0]							
PROP_DATA2	ffaemthr[7:0]							
PROP_DATA3	ffautotxthr[7:0]							

**Notes:** Ffautotxthr applies only when auto transmit is enabled. If ffautotxthr is set to 0, the Si4012 transmits whenever data becomes available in the FIFO. This field is ignored when auto transmit is disabled.

## 5.2.7. PROPERTY: BITRATE\_CONFIG

**Purpose:** Data rate and ramp rate if OOK.

**Property:** 0x31

**Fields:**

- DataRate[9:0]—Data rate in units of 100 bps, ranging from 1 to 1000 for FSK and 1 to 500 for OOK. Default 0x60.
- RampRate[3:0]—Ramp rate in  $\mu$ s. 1, 2, 4, or 8 is supported. Default 2.

**Format:**

DATA_RATE Property	7	6	5	4	3	2	1	0
PROP_ID	0x31							
PROP_DATA1							DataRate[9:8]	
PROP_DATA2	DataRate[7:0]							
PROP_DATA3					RampRate[3:0]			

**Notes:**The data rate won't take into effect until transmission time.

If SET\_PROPERTY\MODULATION\_CONFIG is sent and modulation is set to OOK by the host, but DataRate is set to > 500, Err will be set in the response.

The default modulation type is FSK. If SET\_PROPERTY \MODULATION\_FSKDEV is not sent, any value above 1000 will result in Err being set in the response—0x0D (Data Rate out of Range).

RampRate is ignored if ModuType in MODULATION\_FSKDEV is FSK.  
In OOK mode, any value except 1, 2, 4, or 8 will result in Err 0x04—bad parameter in ARG4.

In FSK mode, the minimum data rate is 200 bps.

The ramp rate parameter dictates the minimum data rate. The Si4012 will set Err to 0x10 (data rate not supported) if the value is smaller than the minimum data rate on the specified Ramp Rate.

Ramp Rate	1	2	4	8
Min Data Rate (bps)	300	200	200	100

## 5.2.8. PROPERTY: TX\_FREQ

**Purpose:** Carrier frequency for transmission if OOK, upper frequency if FSK and center frequency in CW mode.

**Property:** 0x40

**Default:** 0x19ddc7c8 for 433.965 MHz (433.92 MHz+90 kHz/2)

**Fields:** TxFreq[31:0]—Ranging from 27 MHz to 960 MHz.

OOK: Carrier Frequency (Hz)

FSK: Upper Frequency (Hz)

CW Mode: Center Frequency (Hz)

**Format:**

TX_FREQ Property	7	6	5	4	3	2	1	0
PROP_ID	0x40							
PROP_DATA1	TxFreq[31:24]							
PROP_DATA2	TxFreq[23:16]							
PROP_DATA3	TxFreq[15:8]							
PROP_DATA4	TxFreq[7:0]							

**Note:** Frequency out of range in SET\_PROPERTY will result in Err = 0x0E (Frequency out of Range) in the response.

# Si4012

---

## 5.2.9. PROPERTY: LBD\_CONFIG

**Purpose:** Battery voltage threshold used to determine when to raise Low Battery Detector Interrupt, battery voltage sampling interval.

**Property:** 0x41

**Fields:** LbdThr[15:0]—Battery voltage threshold in mV. Default 0x09C4 or 2500 mV.  
SampleInterval[15:0]—Battery voltage sampling interval in seconds.

**Default:** 0x3C or 60 seconds.

**Format:**

LBD_CONFIG Property	7	6	5	4	3	2	1	0
PROP_ID	0x41							
PROP_DATA1	LbdThr[15:8]							
PROP_DATA2	LbdThr[7:0]							
PROP_DATA3	SampleInterval[15:8]							
PROP_DATA4	SampleInterval[7:0]							

**5.2.10. PROPERTY: XO\_CONFIG**

**Purpose:** Frequency of external crystal and low cap configuration if using external crystal.

**Property:** 0x50

**Fields:**

- XoFreq[31:0]—Crystal frequency, unit in Hz. Default 0x00989680 or 10 MHz.
- XoLowCap —This bit should be set for crystal that require less than 14 pF of Cload capacitance. Default 0. See note below.

**Format:**

<b>XO_CONFIG Property</b>	<b>7</b>	<b>6</b>	<b>5</b>	<b>4</b>	<b>3</b>	<b>2</b>	<b>1</b>	<b>0</b>
PROP_ID	0x50							
PROP_DATA1	XoFreq[31:24]							
PROP_DATA2	XoFreq[23:16]							
PROP_DATA3	XoFreq[15:8]							
PROP_DATA4	XoFreq[7:0]							
PROP_DATA5								XoLowCap

**Note:** For correct operation of the oscillator, the user must do the following:

- Check the crystal data sheet for the “Cload” capacitor value that should be placed across the crystal’s terminals to oscillate at the correct frequency
- If Cload > 14 pF, XO\_LOWCAP bit of the XO\_CONFIG property has to be set to 0. In this case, the input capacitance of the XTAL pin of the Si4012 is approximately 5.5 pF, so a (Cload – 5.5)pF capacitor should be placed externally across the crystal terminals.
- If Cload < 14 pF XO\_LOWCAP bit of the XO\_CONFIG property have to be set to 1. In this case, the input capacitance of the XTAL pin of the Si4012 is approximately 3 pF, so the external capacitor placed across the crystal has to be (Cload – 3)pF.

## 5.2.11. PROPERTY: PA\_CONFIG

**Purpose:** PA max current driver, PA level, PA cap, alpha steps and beta steps.

**Property:** 0x60

**Fields:**

- PaMaxDrv—Allows for maximum current drive, calculated from Spreadsheet. Default 1.
- PaLevel[6:0]—PA level calculated from Spreadsheet. Default 70.
- PaCap[8:0]—PA cap. Default 128.
- fAlphaSteps[7:0]—PA Alpha steps, default 125
- fBetaSteps[7:0]—PA Beta steps, default 127

**Format:**

PA_CONFIG Property	7	6	5	4	3	2	1	0
PROP_ID	0x60							
PROP_DATA1								PaMaxDrv
PROP_DATA2	PaLevel[6:0]							
PROP_DATA3								PaCap[8]
PROP_DATA4	PaCap[7:0]							
PROP_DATA5	fAlphaSteps[7:0]							
PROP_DATA6	fBetaSteps[7:0]							

**Note:** fAlphaSteps and fBetaSteps should be calculated by the Si4012 calculator spreadsheet. See AN564 for details. fAlphaSteps specifies the number of steps advancing from the minimum supported value  $-0.075$  with  $0.0006$  per step. The maximum fAlpha is  $+0.075$ . fAlpha is computed using the formula below:

$$f_{\text{ALPHASTEPS}} = \frac{(\text{Alpha} + 0.075)}{0.0006}$$

fBetaSteps specifies the number of steps advancing from the minimum supported value  $-0.254$  with  $0.002$  per step. The maximum fBeta is  $+0.254$ . fBeta is computed using the formula below:

$$f_{\text{BETASTEPS}} = \frac{(\text{Beta} + 0.254)}{0.002}$$

### 5.3. Error Codes

If the Si4012 detects an error upon receipt of a command, such as a bad parameter, the error is reported in the Response.

If the Si4012 detects an error while executing a command after the response has sent back to the host, the error is stored. The host can retrieve an actual error code via the GET\_STATE command.

The table below provides the list of error codes.

Error Code	Description
0x7f	Bad parameter in CMD
0x01	Bad parameter in ARG1
0x02	Bad parameter in ARG2
0x03	Bad parameter in ARG3
0x04	Bad parameter in ARG4
0x05	Bad parameter in ARG5
0x06	Bad parameter in ARG6
0x07	Bad parameter in ARG7
0x08	Too many arguments
0x09	Too few arguments
0x0A	LED on requested but LED driver is disabled
0x0B	State change failed
0x0C	LBD is disabled
0x0D	Data rate is out of range
0x0E	Frequency out of range
0x0F	Internal error
0x10	Data rate not supported
0x11	Device busy
0x12	FIFO overflow
0x13	FIFO underflow

# Si4012

## 6. Pin Descriptions

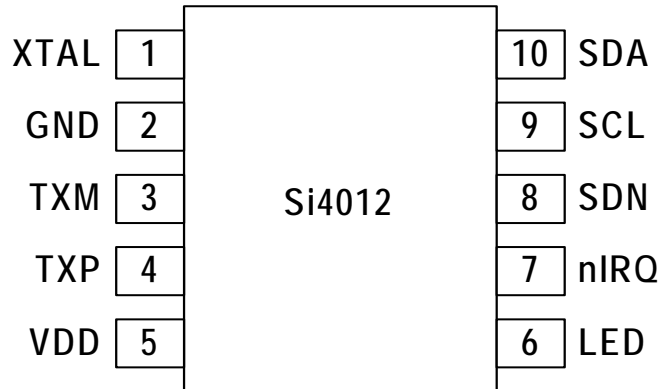

Pin Number	Name	Description
1	XTAL	Crystal input
2	GND	Ground
3,4	TXM, TXP	RF transmitter differential outputs
5	VDD	Supply input
9	LED	LED driver output
7	nIRQ	Interrupt status output, active low, open collector
8	SDN	Shutdown input pin, active high
9	SCL	SMB (SMBus) Clock input/output, open collector
10	SDA	SMB (SMBus) Data input/output, open collector

## 7. Ordering Guide

Part Number*	Description	Package Type	Operating Temperature
Si4012-C1001GT	Crystal-less RF Transmitter	MSOP-10	-40 to 85 °C
Si4012-C1001AT	Crystal-less RF Transmitter (Automotive Grade)	MSOP-10	-40 to 85 °C

**\*Note:** Add an "(R)" at the end of the device part number to denote tape and reel option.

## 8. Package Outline

Figure 9 illustrates the package details for the Si4012. Table 11 lists the values for the dimensions shown in the illustration.

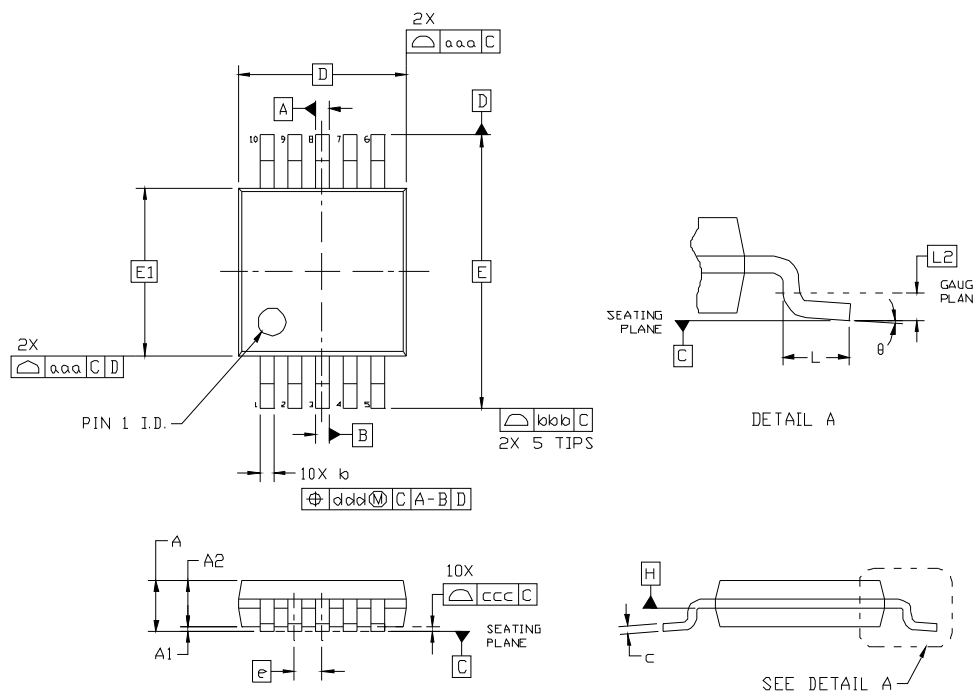

**Figure 9. 10-Pin MSOP Package**

**Table 11. Package Dimensions**

Symbol	Millimeters			Symbol	Millimeters		
	Min	Nom	Max		Min	Nom	Max
A	—	—	1.10	e	0.50 BSC		
A1	0.00	—	0.15	L	0.40	0.60	0.80
A2	0.75	0.85	0.95	L2	0.25 BSC		
b	0.17	—	0.33	q	0°	—	8°
c	0.08	—	0.23	aaa	—	—	0.20
D	3.00 BSC			bbb	—	—	0.25
E	4.90 BSC			ccc	—	—	0.10
E1	3.00 BSC			ddd	—	—	0.08

**Notes:**

1. All dimensions are shown in millimeters (mm).
2. Dimensioning and tolerancing per ASME Y14.5M-1994.
3. This drawing conforms to JEDEC Outline MO-187, Variation "BA."
4. Recommended card reflow profile is per the JEDEC/IPC J-STD-020 specification for Small Body Components.

## 9. Land Pattern: 10-Pin MSOP

Figure 10 shows the recommended land pattern details for the Si4012 in a 10-Pin MSOP package. Table 12 lists the values for the dimensions shown in the illustration.

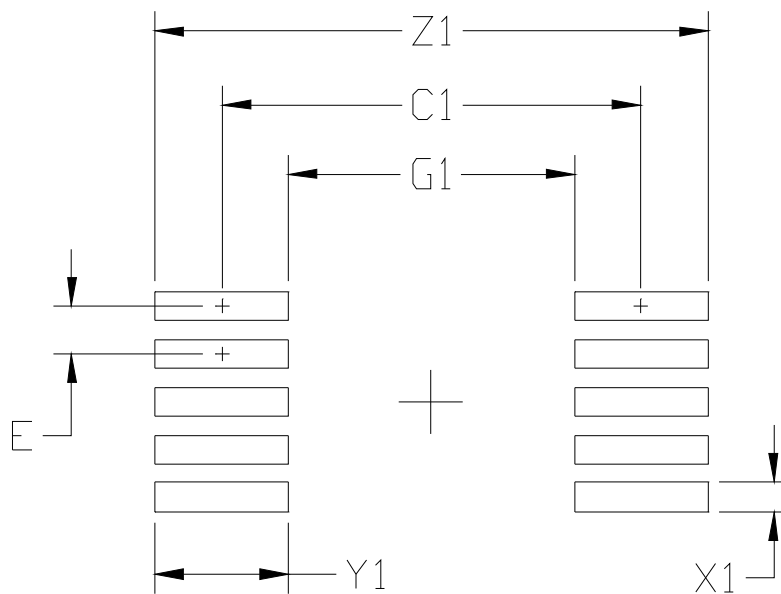

Figure 10. 10-Pin MSOP Land Pattern

Table 12. 10-Pin MSOP Land Pattern Dimensions

Dimension	MIN	MAX
C1	4.40 REF	
E	0.50 BSC	
G1	3.00	—
X1	—	0.30
Y1	1.40 REF	
Z1	—	5.80

**Notes:**

**General**

1. All dimensions shown are in millimeters (mm) unless otherwise noted.
2. Dimensioning and Tolerancing per ASME Y14.5M-1994.
3. This Land Pattern Design is based on the IPC-7351 guidelines.
4. All dimensions shown are at Maximum Material Condition (MMC). Least Material Condition (LMC) is calculated based on a Fabrication Allowance of 0.05 mm.

**Solder Mask Design**

1. All metal pads are to be non-solder mask defined (NSMD). Clearance between the solder mask and the metal pad is to be 60  $\mu\text{m}$  minimum, all the way around the pad.

**Stencil Design**

1. A stainless steel, laser-cut and electro-polished stencil with trapezoidal walls should be used to assure good solder paste release.
2. The stencil thickness should be 0.125 mm (5 mils).
3. The ratio of stencil aperture to land pad size should be 1:1.

**Card Assembly**

1. A No-Clean, Type-3 solder paste is recommended.
2. The recommended card reflow profile is per the JEDEC/IPC J-STD-020 specification for Small Body Components.

## 10. Top Marking: 10-Pin MSOP

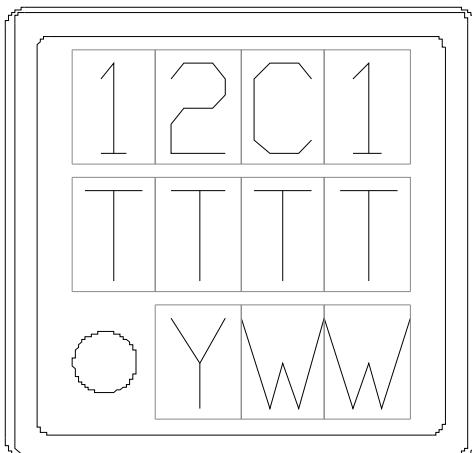

**Figure 11. 10-Pin MSOP Top Marking**

**Table 13. Top Marking Explanation**

<b>Line 1 Marking:</b>	Base Part Number Ordering Options (See "7. Ordering Guide" on page 43).	12 = Si4012 C1 = Revision
<b>Line 2 Marking:</b>	TTTT = Manufacturing Code	Manufacturing code from assembly house.
<b>Line 3 Marking:</b>	Y = Year WW = Workweek	Assigned by assembly subcontractor. Corresponds to the year and workweek of the mold date.

## DOCUMENT CHANGE LIST

### Revision 0.1 to Revision 1.0

- Added API.
- Updated "1. Electrical Specifications" on page 4.

### Revision 1.0 to Revision 1.1

- Added automotive grade version to ordering guide.

**NOTES:**



## Simplicity Studio

One-click access to MCU tools, documentation, software, source code libraries & more. Available for Windows, Mac and Linux!

[www.silabs.com/simplicity](http://www.silabs.com/simplicity)



**MCU Portfolio**  
[www.silabs.com/mcu](http://www.silabs.com/mcu)



**SW/HW**  
[www.silabs.com/simplicity](http://www.silabs.com/simplicity)



**Quality**  
[www.silabs.com/quality](http://www.silabs.com/quality)



**Support and Community**  
[community.silabs.com](http://community.silabs.com)

### Disclaimer

Silicon Laboratories intends to provide customers with the latest, accurate, and in-depth documentation of all peripherals and modules available for system and software implementers using or intending to use the Silicon Laboratories products. Characterization data, available modules and peripherals, memory sizes and memory addresses refer to each specific device, and "Typical" parameters provided can and do vary in different applications. Application examples described herein are for illustrative purposes only. Silicon Laboratories reserves the right to make changes without further notice and limitation to product information, specifications, and descriptions herein, and does not give warranties as to the accuracy or completeness of the included information. Silicon Laboratories shall have no liability for the consequences of use of the information supplied herein. This document does not imply or express copyright licenses granted hereunder to design or fabricate any integrated circuits. The products must not be used within any Life Support System without the specific written consent of Silicon Laboratories. A "Life Support System" is any product or system intended to support or sustain life and/or health, which, if it fails, can be reasonably expected to result in significant personal injury or death. Silicon Laboratories products are generally not intended for military applications. Silicon Laboratories products shall under no circumstances be used in weapons of mass destruction including (but not limited to) nuclear, biological or chemical weapons, or missiles capable of delivering such weapons.

### Trademark Information

Silicon Laboratories Inc., Silicon Laboratories, Silicon Labs, SiLabs and the Silicon Labs logo, CMEMS®, EFM, EFM32, EFR, Energy Micro, Energy Micro logo and combinations thereof, "the world's most energy friendly microcontrollers", Ember®, EZLink®, EZMac®, EZRadio®, EZRadioPRO®, DSPLL®, ISOmodem®, Precision32®, ProSLIC®, SiPHY®, USBXpress® and others are trademarks or registered trademarks of Silicon Laboratories Inc. ARM, CORTEX, Cortex-M3 and THUMB are trademarks or registered trademarks of ARM Holdings. Keil is a registered trademark of ARM Limited. All other products or brand names mentioned herein are trademarks of their respective holders.



Silicon Laboratories Inc.  
400 West Cesar Chavez  
Austin, TX 78701  
USA

<http://www.silabs.com>