

CUSTOMER DRAWING

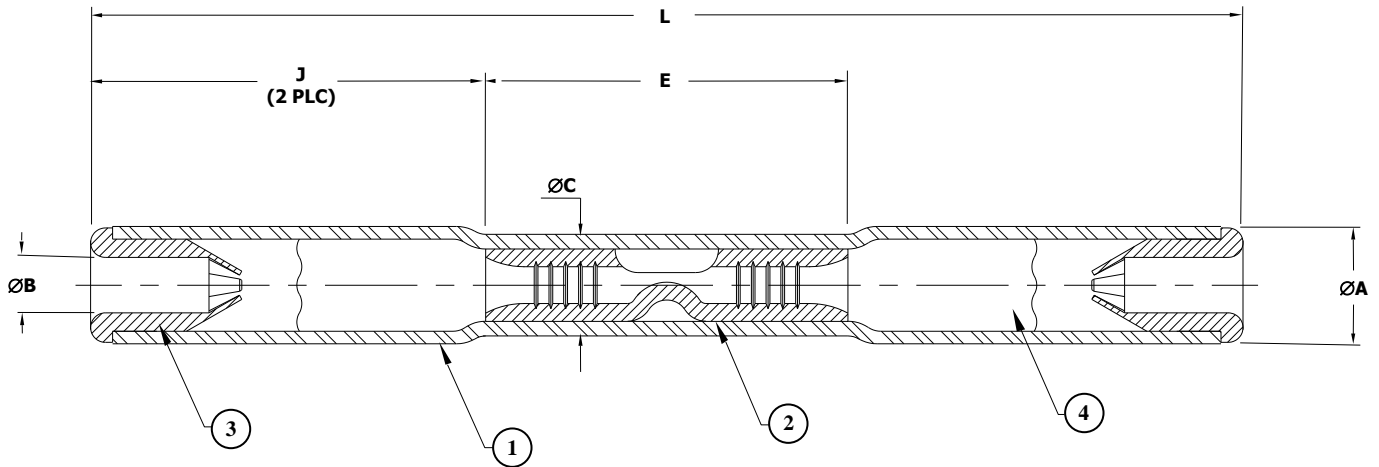

PART NUMBER	WIRE RANGE	L ± 1.0 (±0.040)	ØA ± 0.5 (±0.020)	ØB ± 0.25 (±0.010)	ØC ± 0.5 (±0.020)	E ± 0.25 (±0.010)	J ± 0.50 (±0.020)	END CAP COLOR CODE (BOTH ENDS)
D-436-36-COLD	26-24-22-20	36.8 (1.450)	4.2 (0.165)	2.0 (0.080)	3.7 (0.145)	12.1 (0.475)	12.7 (0.500)	RED
D-436-37-COLD	18-16	37.7 (1.484)	5.1 (0.200)	2.9 (0.115)	4.5 (0.175)	14.3 (0.565)	11.8 (0.464)	BLUE
D-436-38-COLD	14-12	37.7 (1.484)	5.9 (0.235)	3.8 (0.150)	5.2 (0.205)	14.3 (0.565)	11.8 (0.464)	YELLOW

MATERIALS

- INSULATION SLEEVE: Transparent clear, radiation cross-linked modified polyvinylidene fluoride.
- CRIMP:
Base Metal: Copper Alloy 101 or 102 per ASTM B-75, Annealed
Plating: Tin-plate per ASTM-B545
- END CAPS: Thermoplastic, Color Coded (See Table)
- GEL: Clear silicone-based Gel.

APPLICATION

- These parts are designed to provide immersion resistant in-line splices of 1 to 1 wires falling within size range listed above.
- Crimp splices using a Tyco Electronics AD-1381 Crimp Tool.
- Install Cold Crimp Splices per Tyco Electronics RPIP-1102.
- This document takes precedence over documents reference herein.
- Temperature range: -65°C to +150°C.

 TE Connectivity			TITLE: IMMERSION RESISTANT CRIMP SPLICE 150 DEG C, ROHS COMPLIANT COLD APPLIED SPLICE		
Unless otherwise specified dimensions are in millimeters. [Inches dimensions are shown in brackets]		Raychem Devices	DOCUMENT NO.: D-436-3X-COLD		
TOLERANCES: 0.00 N/A 0.0 N/A 0 N/A	ANGLES: N/A ROUGHNESS IN MICRON	Tyco Electronics reserves the right to amend this drawing at any time. Users should evaluate the suitability of the product for their application.		REV:	DATE
REVISED BY: RANJITHA B	CAGE CODE: 06090			ECO NUMBER: ECN-21-116268	B2
			SCALE:	SIZE:	SHEET:
			NTS	A	1 of 1

© 2010-2019 TE Connectivity Corporation. All rights reserved.

If this document is printed it becomes uncontrolled. Check for the latest revision.