

3 V dual and four-line high speed port protection in QFN-4L and QFN-6L

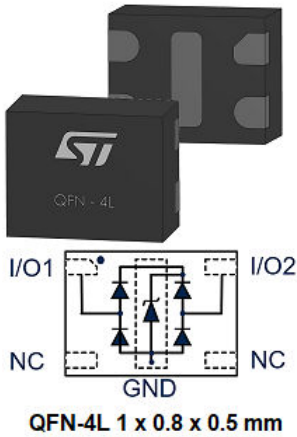
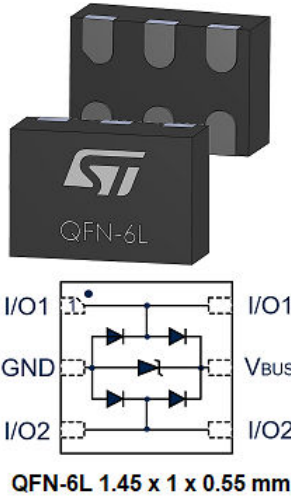

Features

- Flow-through routing to keep signal integrity
- Large bandwidth: 5.5 and 6 GHz
- Ultra low capacitance: 0.6 pF
- Operating junction temperature range: -40 °C to 150 °C
- RoHS compliant and halogen free
- Complies with IEC 61000-4-2 - C = 150 pF, R = 330 Ω exceeds level 4
 - ±8 kV (contact discharge)
 - ±15 kV (air discharge)

Applications

- HDMI 1.4
- DVI
- Display Port
- USB3.0
- SATA
- Ethernet
- HMI

Description

The HSP061-2 series are ESD arrays designed for high speed differential lines.

The ultralow variation of the capacitance ensures negligible influence on signal-skew. The large bandwidth makes it compatible with 5 Gbps.

The HSP061-2M6 is packaged in QFN-6L and the HSP061-2N4 in QFN-4L.

Product status link	Package
HSP061-2M6	QFN-6L
HSP061-2N4	QFN-4L

1 Characteristics

Table 1. Absolute maximum ratings (T_{amb} = 25 °C)

Symbol	Parameter		Value	Unit
V _{PP}	Peak pulse voltage	IEC 61000-4-2 (C = 150 pF, R = 330 Ω)	8	kV
		Contact discharge		
		Air discharge		
I _{PP}	Peak pulse current (8/20 μs)		3	A
T _{stg}	Storage temperature range		-65 to +150	°C
T _j	Operating junction temperature range		-40 to +150	
T _L	Maximum lead temperature for soldering during 10 s		260	

Table 2. Electrical characteristics (T_{amb} = 25 °C)

Symbol	Test conditions	Min.	Typ.	Max.	Unit
V _{BR}	Breakdown voltage at 1 mA	6			V
V _{RM}	Stand-off voltage			3	V
I _{RM}	V _{RM} = 3 V			100	nA
V _{CL}	IEC 61000-4-2, +8 kV contact, measured at 30 ns		18		V
C _{I/O - GND}	Capacitance I/O to ground, V _{I/O} = 0 V, F = 200 to 3000 MHz, V _{OSC} = 30 mV		0.6	0.85	pF
ΔC _{I/O - GND}	Capacitance variation I/O to ground, V _{I/O} = 0 V, F = 200 to 3000 MHz, V _{OSC} = 30 mV		0.03	0.13	pF
f _c	Cut-off frequency at - 3dB	HSP061-2M6	5.5		GHz
		HSP061-2N4	6		

1.1 Characteristics (curves)

Figure 1. Leakage current versus junction temperature

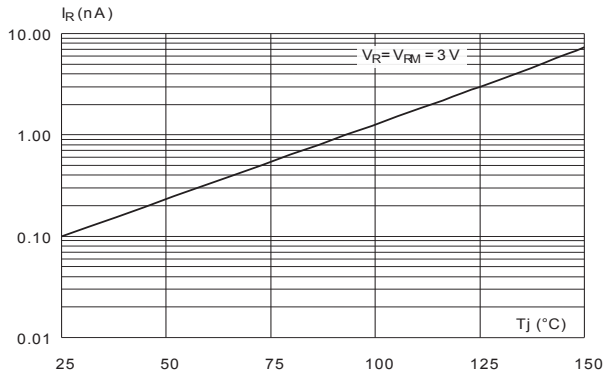

Figure 2. ESD response to IEC 61000-4-2 (+8 kV contact discharge)

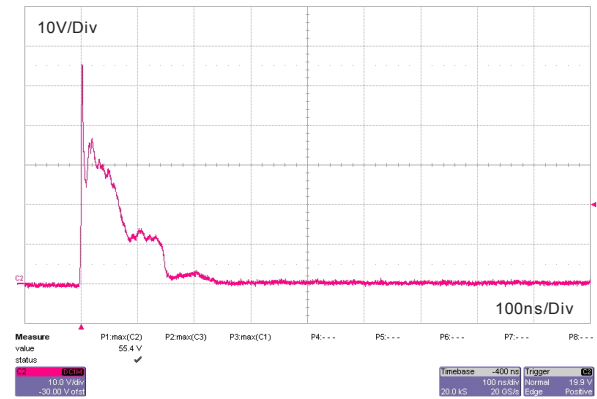

Figure 3. ESD response to IEC 61000-4-2 (-8 kV contact discharge)

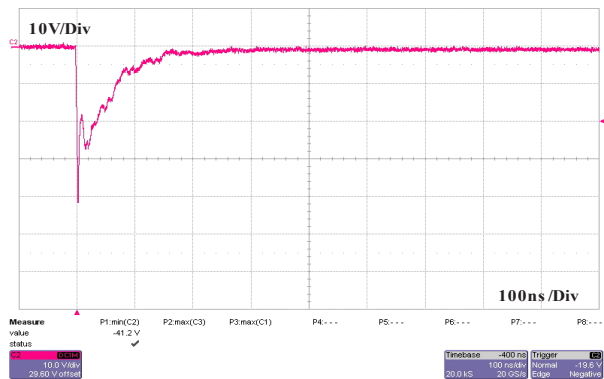

Figure 4. S21 attenuation measurement (HSP061-2M6)

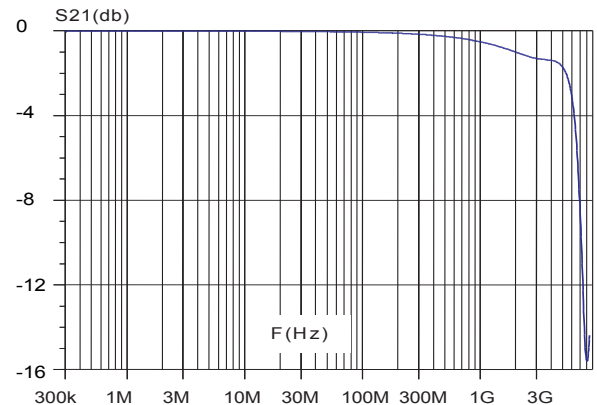

Figure 5. S21 attenuation measurement (HSP061-2N4)

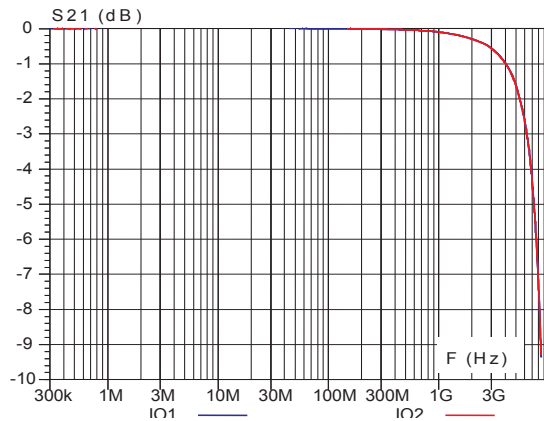

Figure 6. Eye diagram - HDMI mask at 3.4 Gbps (per channel, HSP061-2M6)

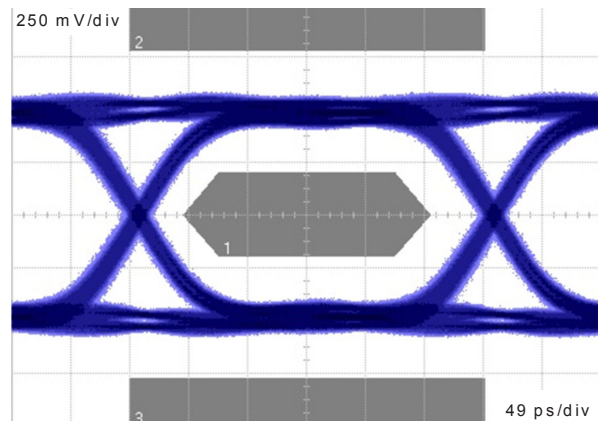
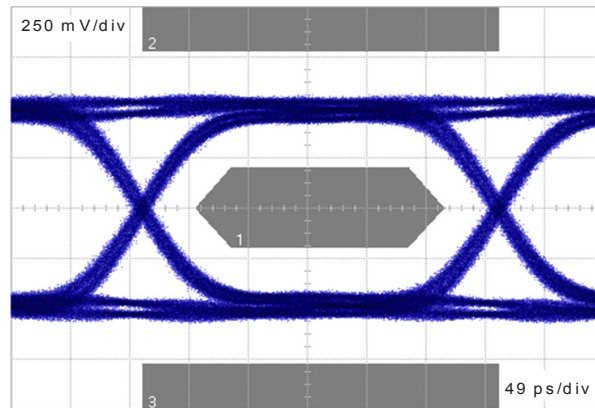

Figure 7. Eye diagram - HDMI mask at 3.4 Gbps (per channel, HSP061-2N4)



Note: HDMI specification conditions. This information can be provided for other applications. Please contact your local ST office.

2 Package information

In order to meet environmental requirements, ST offers these devices in different grades of **ECOPACK** packages, depending on their level of environmental compliance. ECOPACK specifications, grade definitions and product status are available at: www.st.com. ECOPACK is an ST trademark.

2.1 QFN-4L package information

Figure 8. QFN-4L package outline

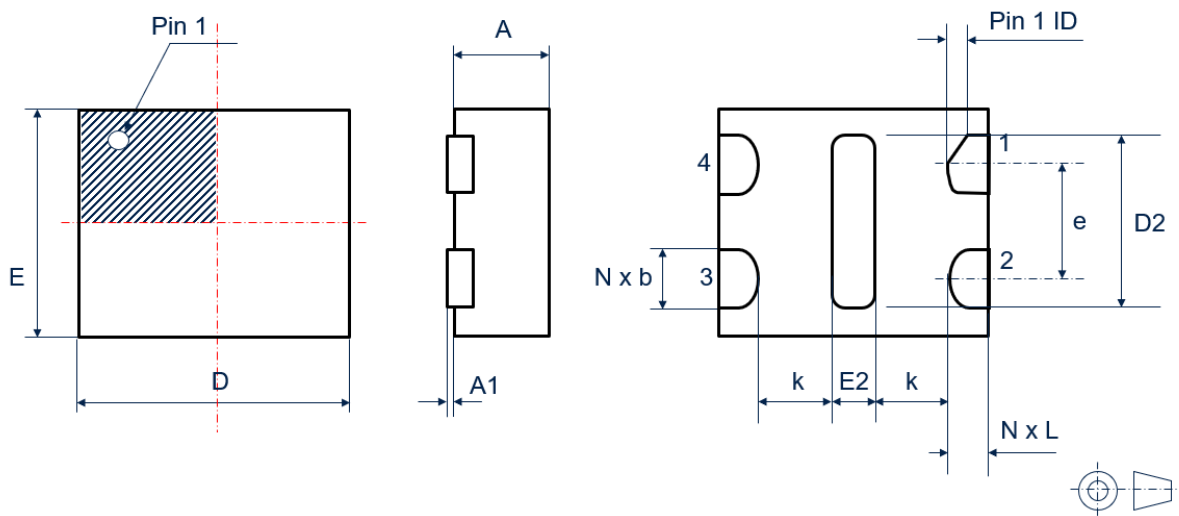

Table 3. QFN-4L package mechanical data

Ref.	Dimensions					
	Millimeters			Inches		
	Min.	Typ.	Max.	Min.	Typ.	Max.
A	0.45	0.50	0.55	0.0177	0.0197	0.0217
A1	0.00	0.02	0.05	0.0000	0.0008	0.0020
b	0.15	0.20	0.25	0.0059	0.0079	0.0099
D	0.95	1.00	1.05	0.0374	0.0394	0.0414
D2	0.55	0.60	0.65	0.0216	0.0236	0.0256
E	0.75	0.80	0.85	0.0295	0.0315	0.0335
E2	0.15	0.20	0.25	0.0059	0.0079	0.0099
e	0.35	0.40	0.45	0.0137	0.0157	0.0178
k	0.17	0.20	0.23	0.0066	0.0079	0.0091
L	0.15	0.20	0.25	0.0059	0.0079	0.0099

2.2 QFN-6L package information

Figure 9. QFN-6L package outline

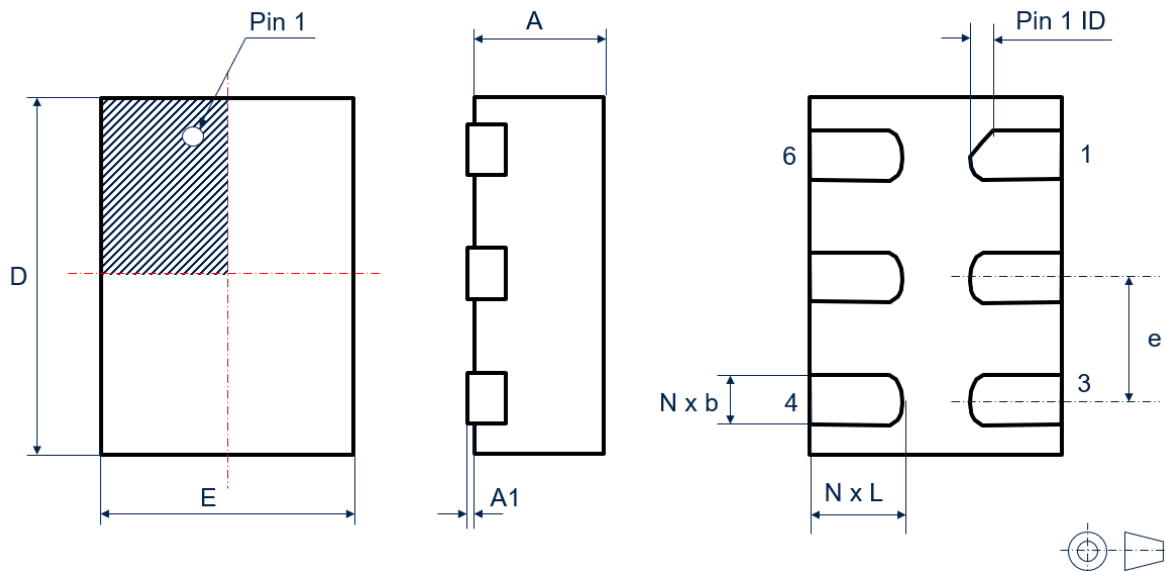

Table 4. QFN-6L package mechanical data

Ref.	Dimensions					
	Millimeters			Inches		
	Min.	Typ.	Max.	Min.	Typ.	Max.
A	0.50	0.55	0.60	0.0196	0.0217	0.0237
A1	0.00	0.02	0.05	0.0000	0.0008	0.0020
b	0.18	0.25	0.30	0.0070	0.0098	0.0119
D	1.40	1.45	1.50	0.0551	0.0571	0.0591
E	0.95	1.00	1.05	0.0374	0.0394	0.0414
e	0.45	0.50	0.55	0.0177	0.0197	0.0217
k	0.20			0.0078		
L	0.30	0.35	0.40	0.0118	0.0138	0.0158

2.3 Packing and marking information (QFN-4L)

Figure 10. Marking layout (refer to ordering information table for marking)

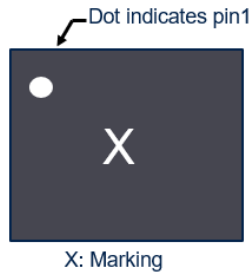
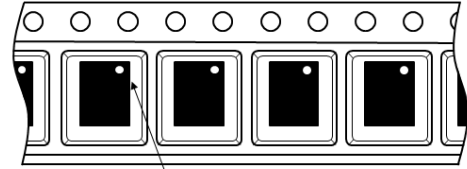

Figure 11. Package orientation in reel



Note: Pocket dimensions are not on scale
Pocket shape may vary depending on package

Figure 12. Tape leader and trailer dimensions

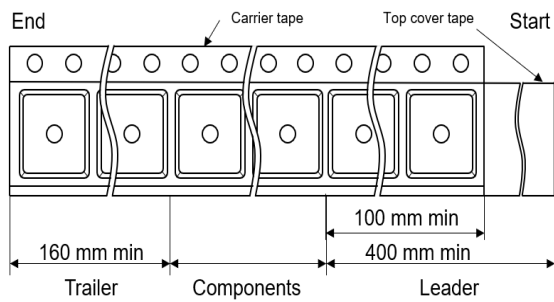

Figure 13. Tape and reel orientation

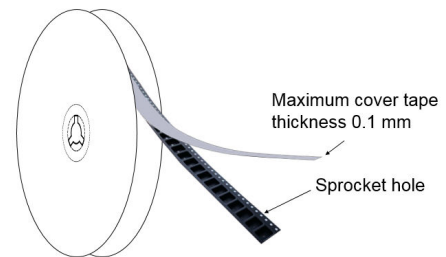

Figure 14. Reel dimensions (mm)

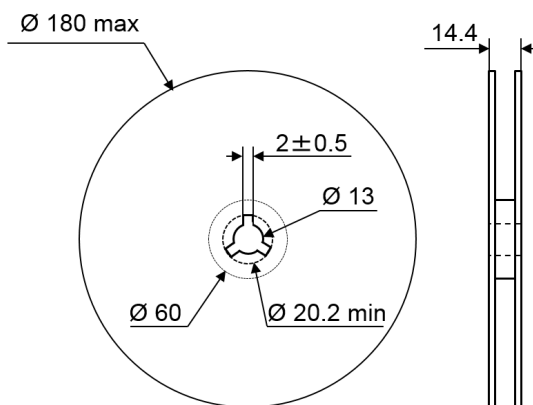

Figure 15. Inner box dimensions (mm)

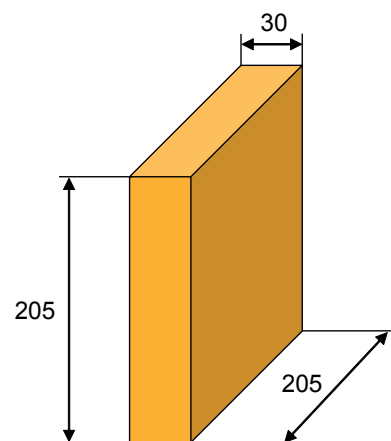
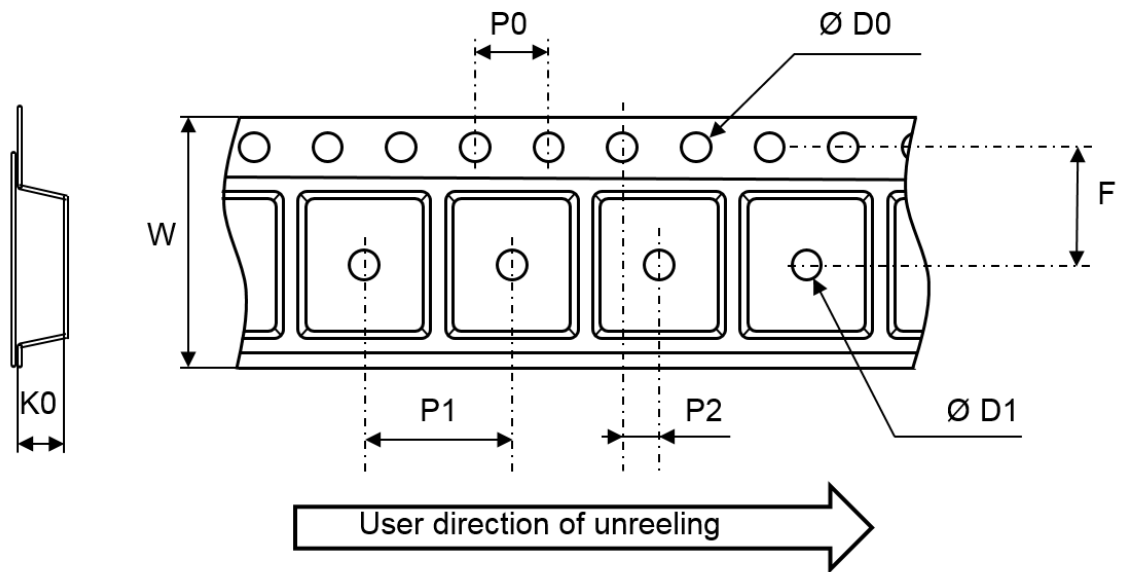

Figure 16. Tape outline



Note: Pocket dimensions are not on scale
Pocket shape may vary depending on package

Table 5. Tape and reel mechanical data

Ref.	Dimensions		
	Millimeters		
	Min.	Typ.	Max.
$\text{Ø } D_0$	1.50	1.55	1.60
$\text{Ø } D_1$	0.39		
F	3.45	3.50	3.55
K0	0.58	0.63	0.68
P0	3.9	4	4.1
P1	1.9	2	2.1
P2	1.95	2	2.05
W	7.9	8	8.3

2.4 Packing and marking information (QFN-6L)

Figure 17. Marking layout (refer to ordering information table for marking)

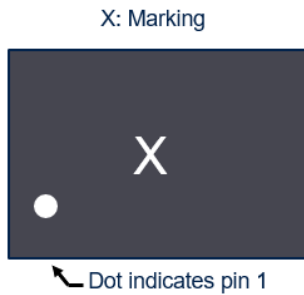
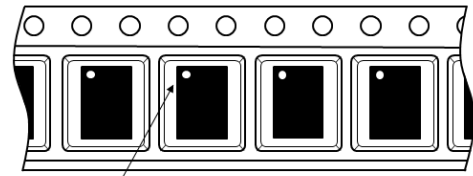

Figure 18. Package orientation in reel



Pin 1 located according to EIA-481

Note: Pocket dimensions are not on scale
Pocket shape may vary depending on package

Figure 19. Tape leader and trailer dimensions

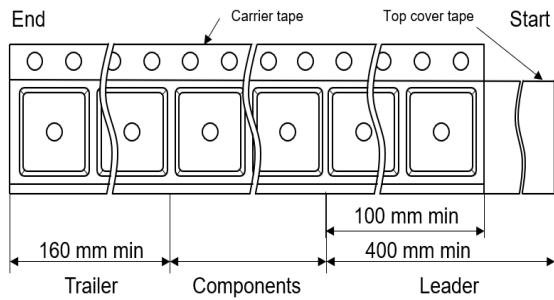

Figure 20. Tape and reel orientation

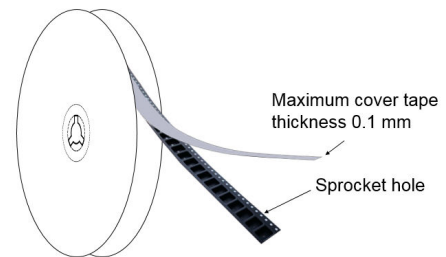

Figure 21. Reel dimensions (mm)

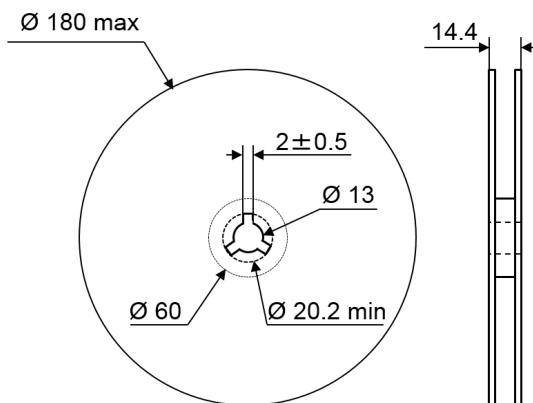

Figure 22. Inner box dimensions (mm)

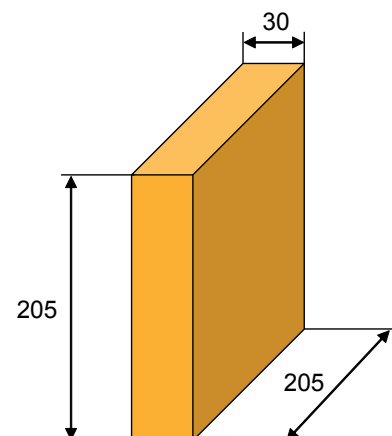
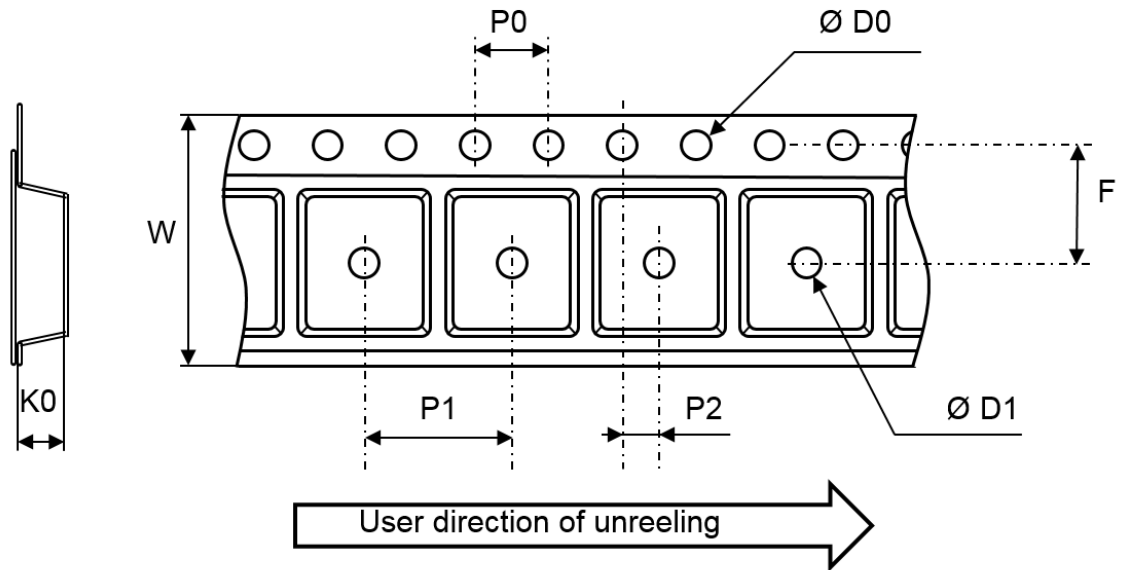

Figure 23. Tape outline



Note: Pocket dimensions are not on scale
Pocket shape may vary depending on package

Table 6. Tape and reel mechanical data

Ref.	Dimensions		
	Millimeters		
	Min.	Typ.	Max.
ØD0	1.50	1.55	1.60
ØD1	0.39		
F	3.45	3.50	3.55
K0	0.7	0.75	0.80
P0	3.9	4	4.1
P1	3.9	4	4.1
P2	1.95	2	2.05
W	7.9	8	8.3

3 Recommendation on PCB assembly

3.1 Recommended footprint and stencil opening for QFN-4L

Stencil opening thickness: 100 μm
Stencil opening ration : 90 %

Figure 24. Recommended footprint and stencil opening

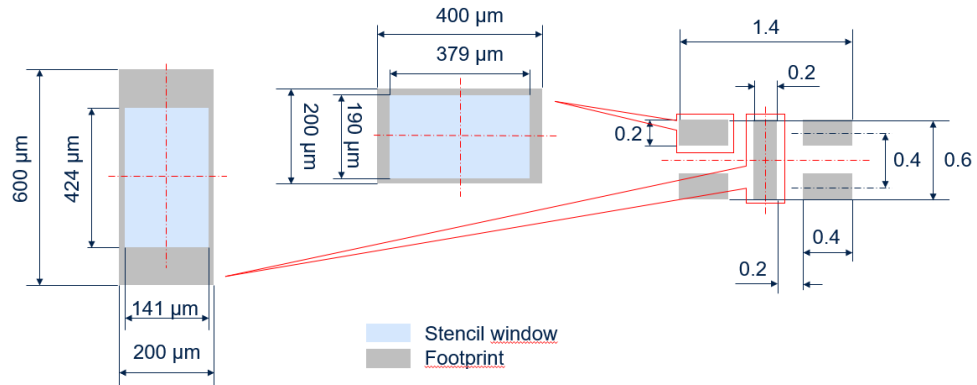

3.2 Recommended footprint and stencil opening for QFN-6L

Stencil opening thickness: 100 μm
Stencil opening ration : 90 %

Figure 25. Recommended footprint in mm

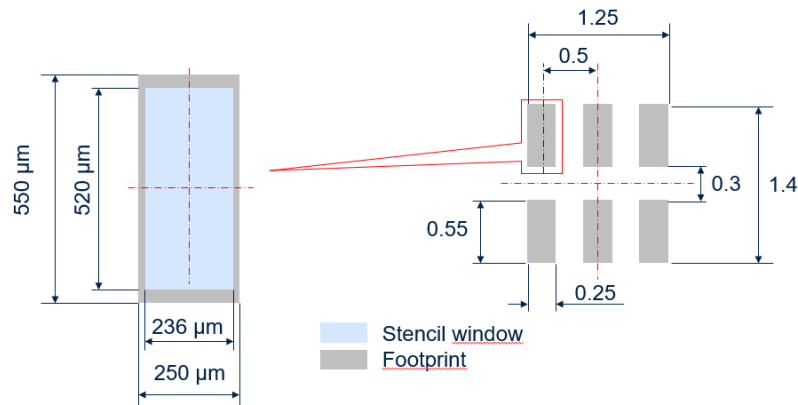

3.3 Solder paste

1. Halide-free flux qualification ROL0 according to ANSI/J-STD-004.
2. "No clean" solder paste is recommended.
3. Offers a high tack force to resist component movement during high speed.
4. Solder paste with fine particles: powder particle size is 20-38 μm .

3.4 Placement

1. Manual positioning is not recommended.
2. It is recommended to use the lead recognition capabilities of the placement system, not the outline centering
3. Standard tolerance of ± 0.05 mm is recommended.
4. 1.0 N placement force is recommended. Too much placement force can lead to squeezed out solder paste and cause solder joints to short. Too low placement force can lead to insufficient contact between package and solder paste that could cause open solder joints or badly centered packages.
5. To improve the package placement accuracy, a bottom side optical control should be performed with a high resolution tool.
6. For assembly, a perfect supporting of the PCB (all the more on flexible PCB) is recommended during solder paste printing, pick and place and reflow soldering by using optimized tools.

3.5 PCB design preference

1. To control the solder paste amount, the closed via is recommended instead of open vias.
2. The position of tracks and open vias in the solder area should be well balanced. A symmetrical layout is recommended, to avoid any tilt phenomena caused by asymmetrical solder paste due to solder flow away.

3.6 Reflow profile

Figure 26. ST ECOPACK[®] recommended soldering reflow profile for PCB mounting

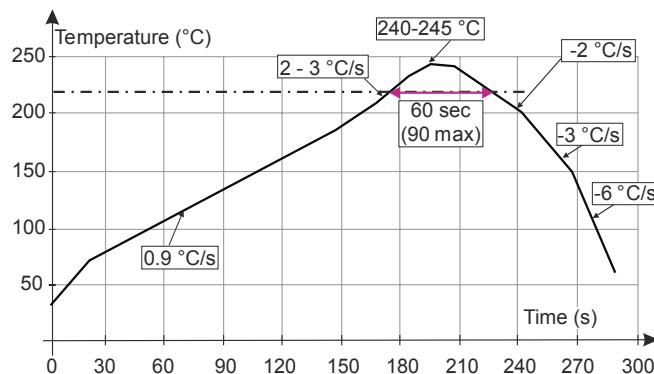

Note: Minimize air convection currents in the reflow oven to avoid component movement.

Note: Maximum soldering profile corresponds to the latest IPC/JEDEC J-STD-020.

4 Ordering information

Table 7. Ordering information

Order code	Marking	Package	Weight	Base qty.	Delivery mode
HSP061-2N4	1	QFN-4L	1.17 mg	10000	Tape and reel
HSP061-2M6	T	QFN-6L	2.3 mg	3000	

Revision history

Table 8. Document revision history

Date	Revision	Changes
07-Feb-2012	1	Initial release.
19-Mar-2014	2	Minor text changes.
13-Oct-2015	3	Removed device in SOT-666. Updated document accordingly.
21-Sep-2023	4	Updated Table 3, Table 4, Section 2.3 Packing and marking information (QFN-4L), Section 2.4 Packing and marking information (QFN-6L), Section 3.1 Recommended footprint and stencil opening for QFN-4L, and Section 3.2 Recommended footprint and stencil opening for QFN-6L. Minor text changes.

IMPORTANT NOTICE – READ CAREFULLY

STMicroelectronics NV and its subsidiaries (“ST”) reserve the right to make changes, corrections, enhancements, modifications, and improvements to ST products and/or to this document at any time without notice. Purchasers should obtain the latest relevant information on ST products before placing orders. ST products are sold pursuant to ST’s terms and conditions of sale in place at the time of order acknowledgment.

Purchasers are solely responsible for the choice, selection, and use of ST products and ST assumes no liability for application assistance or the design of purchasers’ products.

No license, express or implied, to any intellectual property right is granted by ST herein.

Resale of ST products with provisions different from the information set forth herein shall void any warranty granted by ST for such product.

ST and the ST logo are trademarks of ST. For additional information about ST trademarks, refer to www.st.com/trademarks. All other product or service names are the property of their respective owners.

Information in this document supersedes and replaces information previously supplied in any prior versions of this document.

© 2023 STMicroelectronics – All rights reserved