

**(0.80 mm) .0315" PITCH • QTE/QSE SERIES**

**QTE**  
Board Mates:  
QSE

**QSE**  
Board Mates:  
QTE

**QTE/QSE**  
Cable Mates:  
EQCD, EQDP

**Standoffs:**  
SO

QTE	PINS PER ROW NO. OF PAIRS	LEAD STYLE	PLATING OPTION	TYPE	A	OTHER OPTIONS	"X"R
	-020, -040, -060 (40 total pins per bank = -D)	Specify LEAD STYLE from Chart	-F = Gold flash on contact, Matte Tin on tail  -L = 10 μ" (0.25 μm) Gold on contact, Matte Tin on tail  -C = 50 μ" (1.27 μm) Electro-Polished Selective Gold on contact, Matte Tin on tail (passes 10 year MFG testing)	-D = Single-Ended  -D-DP = Differential Pair (-01 only)		-K = (7.00 mm) .275" DIA Polyimide film Pick & Place Pad  -L = Latching Option (N/A on -042 & -060 positions)	Leave blank for Tray Packaging  -TR =Tape & Reel (Not available with -05 & -07 lead style)  -FR = Full Reel Tape & Reel (must order max. quantity per reel; contact Samtec for quantity breaks) (Not available with -05 & -07 lead style)

**SPECIFICATIONS**

**Insulator Material:** Liquid Crystal Polymer  
**Contact Material:** Phosphor Bronze  
**Plating:** Au or Sn over 50 μ" (1.27 μm) Ni  
**Operating Temp Range:** -55 °C to +125 °C  
**Current Rating:** Contact: 2 A per pin (2 pins powered) Ground Plane: 23 A per ground plane (1 ground plane powered)  
**Voltage Rating:** 225 VAC/318 VDC  
**Max Cycles:** 100

QTE LEAD STYLE	A	HEIGHT WITH QSE*
-01	(4.27) .168	(5.00) .197
-02	(7.26) .286	(8.00) .315
-03	(10.27) .404	(11.00) .433
-04	(15.25) .600	(16.00) .630
-05	(18.26) .718	(19.00) .748
-07	(24.24) .954	(25.00) .984
-09	(13.26) .522	(14.00) .551

\*Processing conditions will affect mated height. See SO Series for board space tolerances.

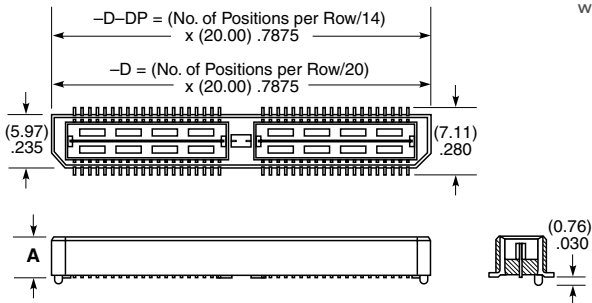

**PROCESSING**

**Lead-Free Solderable:** Yes  
**SMT Lead Coplanarity:** (0.10 mm) .004" max (020-060)  
**Board Stacking:** For applications requiring more than two connectors contact ipg@samtec.com

View complete specifications at: [samtec.com?QTE](http://samtec.com?QTE)



QSE	PINS PER ROW NO. OF PAIRS	01	PLATING OPTION	TYPE	A	OTHER OPTIONS	"X"R
	-020, -040, -060 (40 total pins per bank = -D)  -014, -028, -042 (14 pairs per bank = -D-DP)		-F = Gold flash on contact, Matte Tin on tail  -L = 10 μ" (0.25 μm) Gold on contact, Matte Tin on tail  -C = 50 μ" (1.27 μm) Electro-Polished Selective Gold on contact, Matte Tin on tail (passes 10 year MFG testing)	-D = Single-Ended  -D-DP = Differential Pair		-GP = Guide Post  -K = (8.25 mm) .325" DIA Polyimide Film Pick & Place Pad  -L = Latching Option (Not available on -042 & -060 positions)	Leave blank for Tray Packaging  -TR =Tape & Reel (40 positions max. with -GP)  -FR = Full Reel Tape & Reel (must order max. quantity per reel; contact Samtec for quantity breaks) (40 positions max. with -GP)

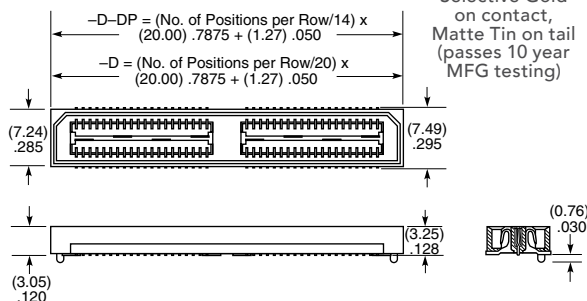

**Note:** Some lengths, styles and options are non-standard, non-returnable.

View complete specifications at: [samtec.com?QSE](http://samtec.com?QSE)