

| REVISIONS | | | | | |
|-----------|-----|---------------------------|-----------|-----|------|
| P | LTR | DESCRIPTION | DATE | DWN | APVD |
| | Y2 | REVISED PER ECN-23-201875 | 08MAR2023 | RK | MF |

- 8 OBSOLETE PART NO., REFER TO DWG 104909 FOR POS 13 THRU 25.
- 9 HOUSING: HIGH TEMPERATURE LCP, COLOR-BLACK. POSTS: BRASS.
- 10 0.000381 [.000015] GOLD IN THE CONTACT AREA, 0.00254-0.00508 [.000100-.000200] MATTE TIN ON THE SOLDER TAIL, ALL OVER ALL OVER 0.00127 [.000050] NICKEL.
- 11 SUPERSEDED
- 12 0.25 [.010] RECESS PERMISSIBLE IN THIS AREA FOR MOLD SHUT OFF

| PART NO. | SUPERSEDED BY |
|------------|---------------|
| 1-104362-2 | 1-104909-2 |
| 1-104362-4 | 1-104909-4 |
| 1-104362-7 | 1-104909-7 |
| 2-104362-2 | --- |
| 2-104362-3 | --- |

- 1 0.000381 [.000015] GOLD IN THE CONTACT AREA, 0.00254-0.00508 [.000100-.000200] MATTE TIN-LEAD ON THE SOLDER TAIL, ALL OVER ALL OVER 0.00127 [.000050] NICKEL.
- 2 POINT OF MEASUREMENT FOR PLATING THICKNESS
- 3 THE NOTED DIMENSIONS APPLY FROM THE BASIC DIMENSION LINE (NOT THE POST CENTERLINE) TO THE SURFACE INDICATED
- 4 ONE POLARIZATION SLOT FOR 2 AND 3 POSITION ASSEMBLIES ONLY.
- 5 SELECT POST TAILS FORMED TO PROVIDE CONNECTOR HOLD DOWN UNTIL SOLDERED, CONFIGURATION ACCEPTS 0.69-2.03 [.027-.080] THICK PRINTED CIRCUIT BOARD (SEE DETAIL Z).
- 6 DIMENSIONS NOTED ARE FOR SOLDER STENCIL LAYOUT FOR USE WITH 1.57±0.20 [.062±.008] THICK PRINTED CIRCUIT BOARDS.
- 7 PARTS ARE PACKAGED IN GANG OF TUBES

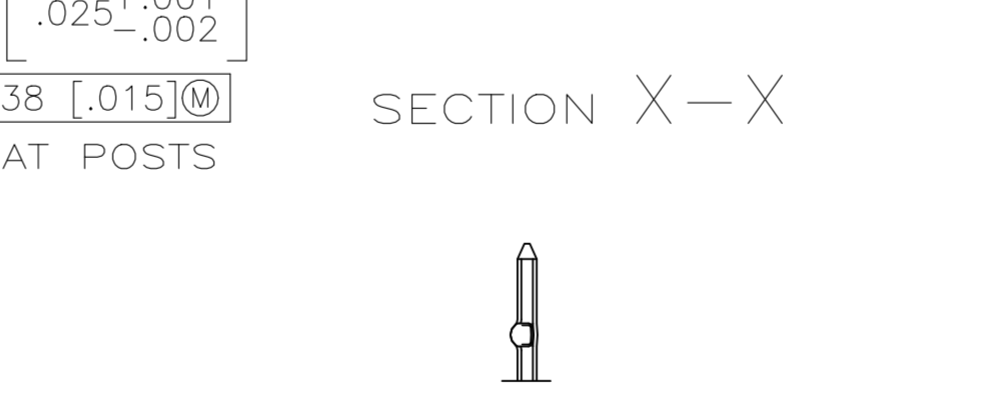
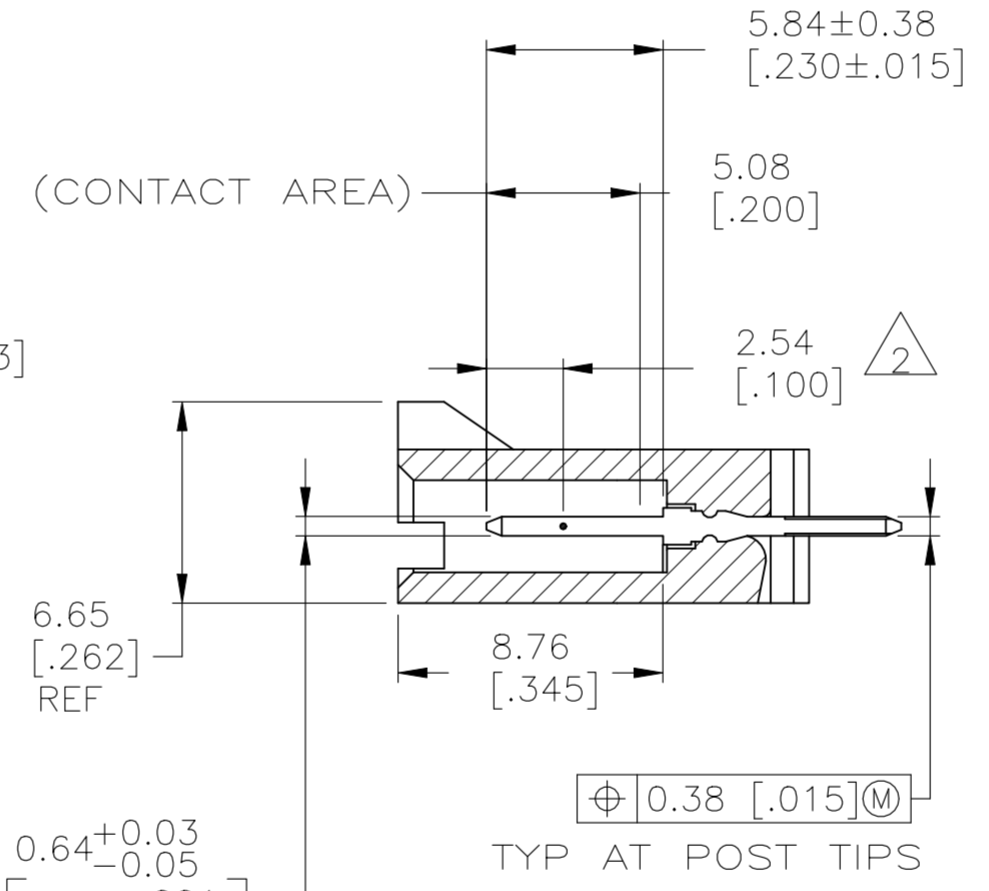
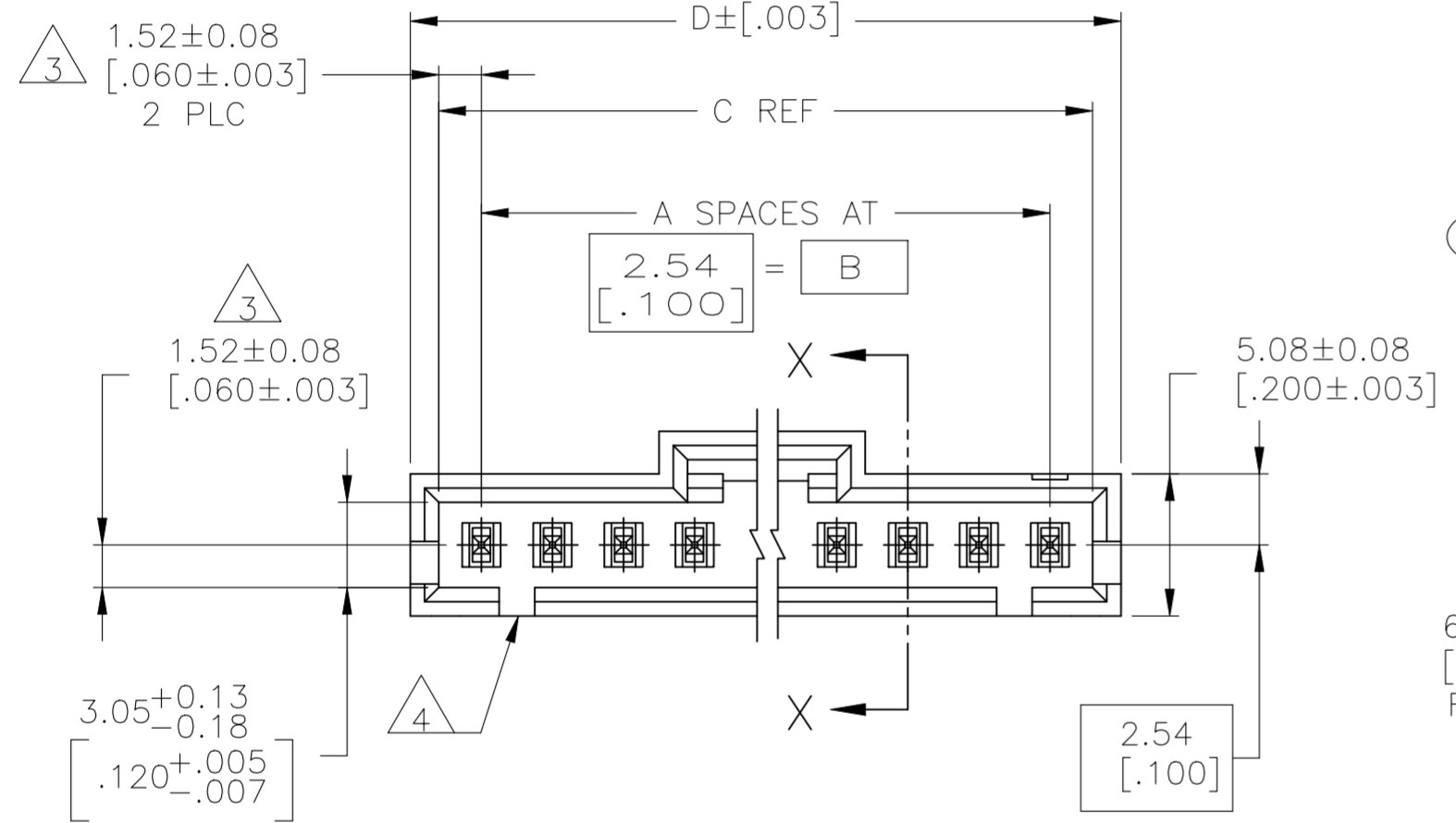
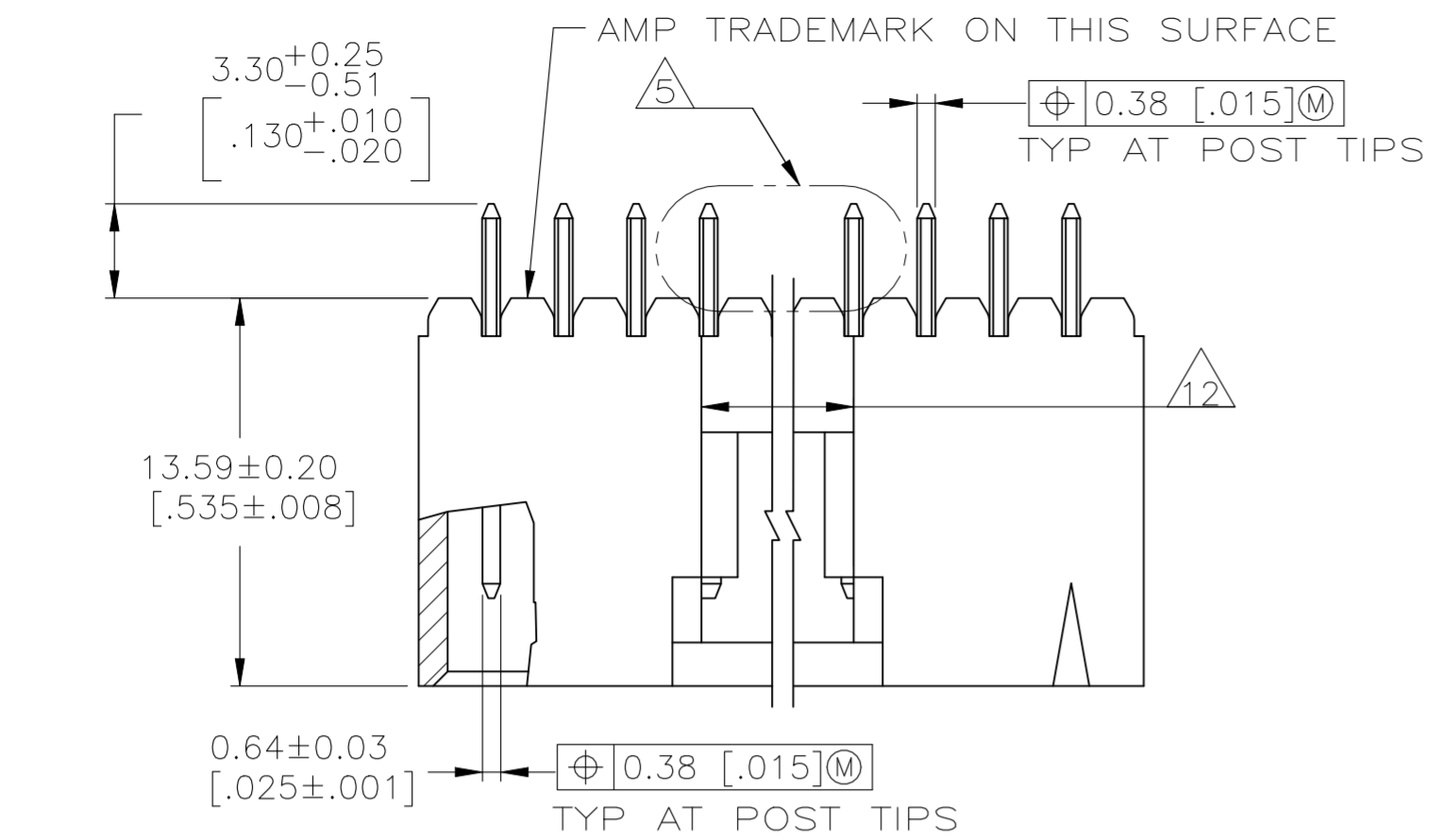

| | | | | | | |
|----|---------------|---------------|---------------|----|----|------------|
| 10 | 32.89 [1.295] | 30.99 [1.220] | 27.94 [1.100] | 11 | 12 | 6-104362-1 |
| 10 | 30.35 [1.195] | 28.45 [1.120] | 25.4 [1.000] | 10 | 11 | 6-104362-0 |
| 10 | 27.81 [1.095] | 25.91 [1.020] | 22.86 [.900] | 9 | 10 | 5-104362-9 |
| 10 | 25.27 [0.995] | 23.37 [.920] | 20.32 [.800] | 8 | 9 | 5-104362-8 |
| 10 | 22.73 [.895] | 20.83 [.820] | 17.78 [.700] | 7 | 8 | 5-104362-7 |
| 10 | 20.19 [.795] | 18.29 [.720] | 15.24 [.600] | 6 | 7 | 5-104362-6 |
| 10 | 17.65 [.695] | 15.75 [.620] | 12.7 [.500] | 5 | 6 | 5-104362-5 |
| 10 | 15.11 [.595] | 13.21 [.520] | 10.16 [.400] | 4 | 5 | 5-104362-4 |
| 10 | 12.57 [.495] | 10.67 [.420] | 7.62 [.300] | 3 | 4 | 5-104362-3 |
| 10 | 10.03 [.395] | 8.13 [.320] | 5.08 [.200] | 2 | 3 | 5-104362-2 |
| 10 | 7.49 [.295] | 5.59 [.220] | 2.54 [.100] | 1 | 2 | 5-104362-1 |
| | 65.91 [2.595] | 64.01 [2.520] | 60.96 [2.400] | 24 | 25 | 2-104362-4 |
| | 63.37 [2.495] | 61.47 [2.420] | 58.42 [2.300] | 23 | 24 | 2-104362-3 |
| | 60.83 [2.395] | 58.93 [2.320] | 55.88 [2.200] | 22 | 23 | 2-104362-2 |
| | 58.29 [2.295] | 56.39 [2.220] | 53.34 [2.100] | 21 | 22 | 2-104362-1 |
| | 55.75 [2.195] | 53.85 [2.120] | 50.8 [2.000] | 20 | 21 | 2-104362-0 |
| | 53.21 [2.095] | 51.31 [2.020] | 48.26 [1.900] | 19 | 20 | 1-104362-9 |
| | 50.67 [1.995] | 48.77 [1.920] | 45.72 [1.800] | 18 | 19 | 1-104362-8 |
| | 48.13 [1.895] | 46.23 [1.820] | 43.18 [1.700] | 17 | 18 | 1-104362-7 |
| | 45.59 [1.795] | 43.69 [1.720] | 40.64 [1.600] | 16 | 17 | 1-104362-6 |
| | 43.05 [1.695] | 41.15 [1.620] | 38.1 [1.500] | 15 | 16 | 1-104362-5 |
| | 40.51 [1.595] | 38.61 [1.520] | 35.56 [1.400] | 14 | 15 | 1-104362-4 |
| | 37.97 [1.495] | 36.07 [1.420] | 33.02 [1.300] | 13 | 14 | 1-104362-3 |
| | 35.43 [1.395] | 33.53 [1.320] | 30.48 [1.200] | 12 | 13 | 1-104362-2 |
| 1 | 32.89 [1.295] | 30.99 [1.220] | 27.94 [1.100] | 11 | 12 | 1-104362-1 |
| 1 | 30.35 [1.195] | 28.45 [1.120] | 25.4 [1.000] | 10 | 11 | 1-104362-0 |
| 1 | 27.81 [1.095] | 25.91 [1.020] | 22.86 [.900] | 9 | 10 | 104362-9 |
| 1 | 25.27 [0.995] | 23.37 [.920] | 20.32 [.800] | 8 | 9 | 104362-8 |
| 1 | 22.73 [.895] | 20.83 [.820] | 17.78 [.700] | 7 | 8 | 104362-7 |
| 1 | 20.19 [.795] | 18.29 [.720] | 15.24 [.600] | 6 | 7 | 104362-6 |
| 1 | 17.65 [.695] | 15.75 [.620] | 12.7 [.500] | 5 | 6 | 104362-5 |
| 1 | 15.11 [.595] | 13.21 [.520] | 10.16 [.400] | 4 | 5 | 104362-4 |
| 1 | 12.57 [.495] | 10.67 [.420] | 7.62 [.300] | 3 | 4 | 104362-3 |
| 1 | 10.03 [.395] | 8.13 [.320] | 5.08 [.200] | 2 | 3 | 104362-2 |
| 1 | 7.49 [.295] | 5.59 [.220] | 2.54 [.100] | 1 | 2 | 104362-1 |

| PLATING | D | C | B | A | NO OF POSN | ASSEMBLY PART NUMBER |
|---------|---|---|---|---|------------|----------------------|
| | | | | | | |

THIS DRAWING IS A CONTROLLED DOCUMENT.

DIMENSIONS: mm [INCHES]

TOLERANCES UNLESS OTHERWISE SPECIFIED:

| | | |
|--------|---|------|
| 0 PLC | ± | - |
| 1 PLC | ± | - |
| 2 PLC | ± | - |
| 3 PLC | ± | .005 |
| 4 PLC | ± | - |
| ANGLES | ± | - |

MATERIAL: SEE TABLE

FINISH: SEE TABLE

DWN: G DOUTY 2-22-88

CHK: T C CLARK 2-22-88

APVD: -

PRODUCT SPEC: -

APPLICATION SPEC: -

WEIGHT: -

CUSTOMER DRAWING

TE Connectivity

HEADER ASSY, AMPMODU MTE, VERTICAL SINGLE ROW, .100 C/L, .025 SQ POST POLARIZED, WITH LATCHING & HOLD DOWN

SIZE: A2 CAGE CODE: 00779 DRAWING NO: C=104362 RESTRICTED TO: -

SCALE: 4:1 SHEET: 1 of 1 REV: Y2

RECOMMENDED PC BOARD MOUNTING DIMENSIONS
RECOMMENDED STENCIL THICKNESS = 0.25 [.010]

Mouser Electronics

Authorized Distributor

Click to View Pricing, Inventory, Delivery & Lifecycle Information:

[TE Connectivity:](#)

[5-104362-9](#)