

2.7 V to 5.5 V Input, 2 A Single Synchronous Buck DC/DC Converter for Automotive

BD9S209NUX-C

General Description

BD9S209NUX-C is a synchronous buck DC/DC Converter with built-in low On Resistance power MOSFETs. It is capable of providing current up to 2 A. Small inductor is applicable due to high switching frequency of 2.2 MHz. It is a current mode control DC/DC Converter and features high-speed transient response. It has a built-in phase compensation circuit. Applications can be created with a few external components.

Features

- AEC-Q100 Qualified^(Note 1)
- Single Synchronous Buck DC/DC Converter
- Adjustable Soft Start Function
- Output Discharge Function
- Power Good Output
- Input Under Voltage Lockout Protection (UVLO)
- Short Circuit Protection (SCP)
- Output Over Voltage Protection (OVP)
- Over Current Protection (OCP)
- Thermal Shutdown Protection (TSD)

(Note 1) Grade 1

Applications

- Automotive Equipment
- Other Electronic Equipment

Key Specifications

■ Input Voltage:	2.7 V to 5.5 V
■ Output Voltage Setting:	0.8 V to V_{IN}
■ Output Current:	2 A (Max)
■ Switching Frequency:	2.2 MHz (Typ)
■ High Side FET ON Resistance:	150 mΩ (Typ)
■ Low Side FET ON Resistance:	95 mΩ (Typ)
■ Shutdown Circuit Current:	0 μA (Typ)
■ Operating Temperature:	-40 °C to +125 °C

Package

VSON008X2020

W (Typ) x D (Typ) x H (Max)

2.0 mm x 2.0 mm x 0.6 mm

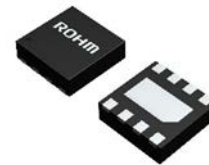

Typical Application Circuit

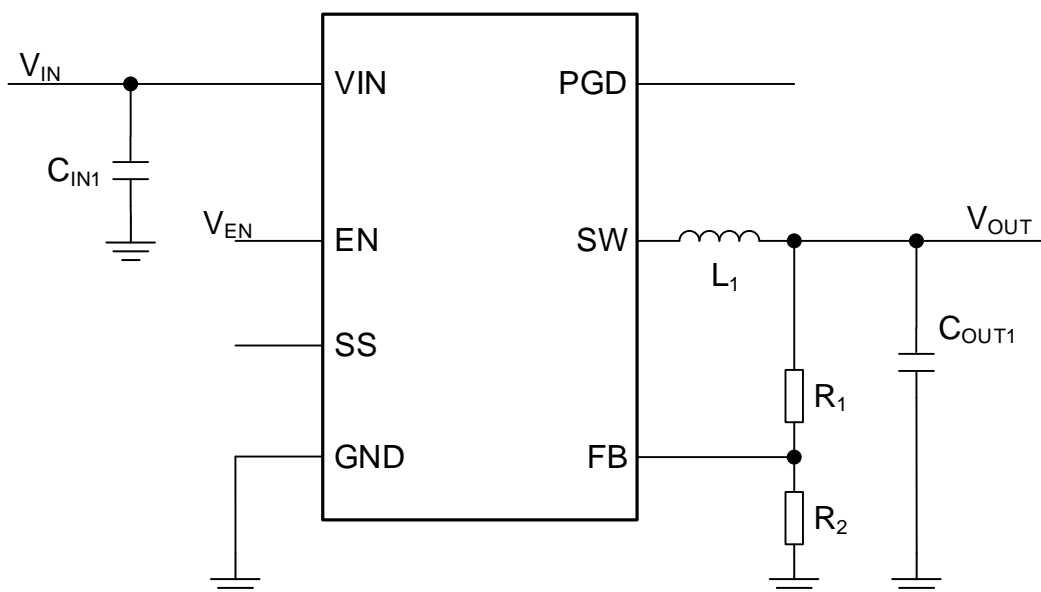

○Product structure : Silicon integrated circuit ○This product has no designed protection against radioactive rays

www.rohm.com

© 2022 ROHM Co., Ltd. All rights reserved.
TSZ22111 • 14 • 001

1/37

TSZ02201-0T4T0AA01670-1-2
06.Apr.2022 Rev.001

Pin Configuration

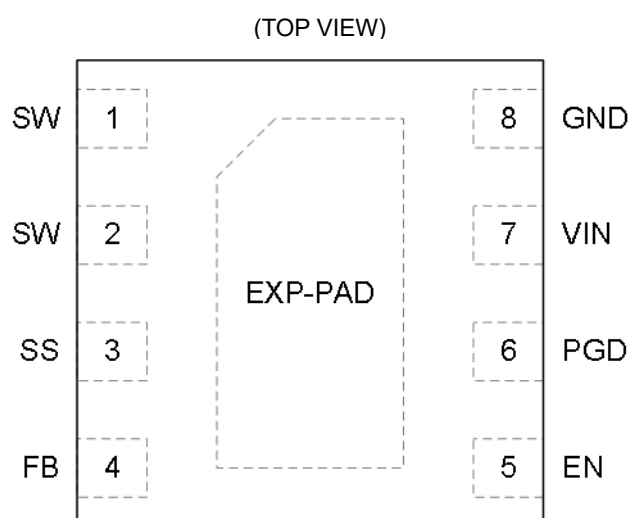

Pin Descriptions

Pin No.	Pin Name	Function
1, 2	SW	Switch pin. These pins are connected to the drain of the High Side FET and the Low Side FET.
3	SS	Pin for setting the soft start time. The rise time of the output voltage can be specified by connecting a capacitor to this pin. See Selection of Components Externally Connected 5. Selection of Soft Start Capacitor for how to calculate the capacitance.
4	FB	V_{OUT} feedback pin. Connect output voltage divider to this pin to set the output voltage. See Selection of Components Externally Connected 2. Selection of Output Voltage Setting on how to compute for the resistor values.
5	EN	Enable pin of the device. Turning this pin Low forces the device to enter the shutdown mode. Turning this pin High makes the device to start up.
6	PGD	Power Good pin, an open drain output. It is need to be pulled up to the power supply with a resistor. See Function Explanations 2. Power Good Output for setting the resistance.
7	VIN	Power supply pin. Connecting a 10 μ F (Typ) ceramic capacitor is recommended. The detail of a selection is described in Selection of Components Externally Connected 3. Selection of Input Capacitor .
8	GND	Ground pin.
-	EXP-PAD	A backside heat dissipation pad. Connecting to the internal PCB ground plane by using via provides excellent heat dissipation characteristics.

Block Diagram

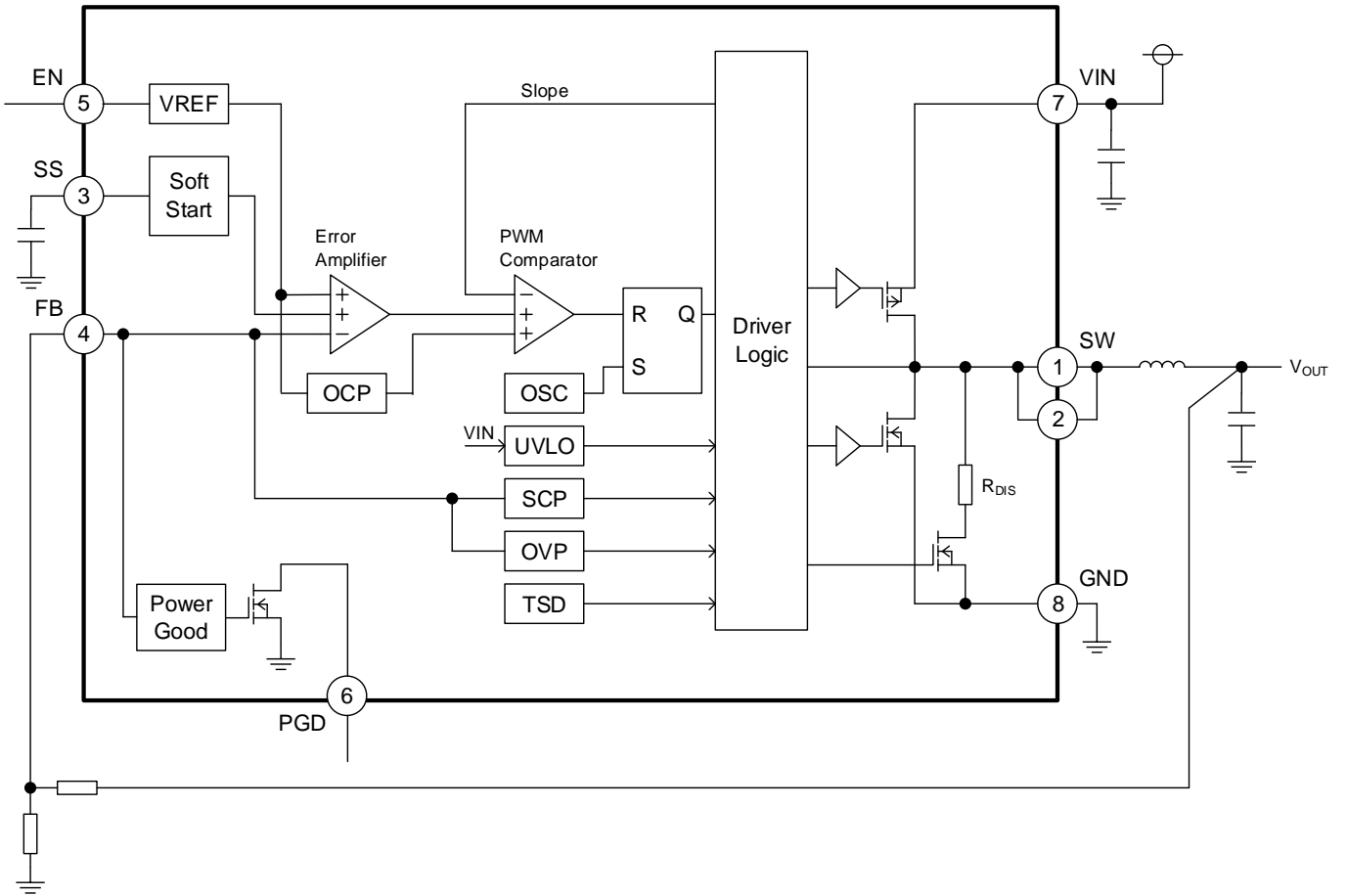

Description of Blocks

- 1. VREF**
The VREF block generates the internal reference voltage.
- 2. UVLO (Under Voltage Lockout)**
The UVLO block is for under voltage lockout protection. It shuts down the device when the V_{IN} falls to 2.45 V (Typ) or less. The threshold voltage has a hysteresis of 100 mV (Typ).
- 3. SCP (Short Circuit Protection)**
This is the short circuit protection circuit. After soft start is judged to be completed, if the FB pin voltage falls to 0.56 V (Typ) or less and remain in that state for 1 ms (Typ), output MOSFETs turn OFF for 14 ms (Typ) and then restart the operation.
- 4. OVP (Over Voltage Protection)**
This is the output over voltage protection circuit. When the FB pin voltage becomes 0.88 V (Typ) or more, it turns the output MOSFETs OFF. After output voltage falls 0.856 V (Typ) or less, the output MOSFETs return to normal operation.
- 5. TSD (Thermal Shutdown)**
This is the thermal shutdown circuit. It shuts down the device when the junction temperature (T_j) reaches to 175 °C (Typ) or more. When the T_j falls below the TSD threshold, the circuits are automatically restored to normal operation with hysteresis of 25 °C (Typ).
- 6. OCP (Over Current Protection)**
The Over Current Protection function operates by limiting the current that flows through High Side FET at each cycle of the switching frequency.
- 7. Soft Start**
The Soft Start circuit slows down the rise of output voltage during startup, which allows the prevention of output voltage overshoot. The soft start time of the output voltage can be specified by connecting a capacitor to the SS pin. See [Selection of Components Externally Connected 5. Selection of Soft Start Capacitor](#) for how to calculate the capacitance. A built-in soft start function is provided the soft start with Soft Start Time t_{ss} ([Electrical Characteristics](#)) when the SS pin is open.
- 8. Error Amplifier**
The Error Amplifier block is an error amplifier and its inputs are the reference voltage and the FB pin voltage.
- 9. PWM Comparator**
The PWM Comparator block compares the output voltage of the Error Amplifier and the Slope signal to determine the output switching pulse duty.
- 10. OSC (Oscillator)**
This block generates the oscillating frequency.
- 11. Driver Logic**
This block controls switching operation and various protection functions.
- 12. Power Good**
When the FB pin voltage reaches 0.8 V (Typ) within $\pm 7\%$, the built-in Nch MOSFET turns OFF and the PGD output turns high. There is a 3 % hysteresis on the threshold voltage, so the PGD output turns low when the FB pin voltage reaches outside $\pm 10\%$ of 0.8 V (Typ).

Absolute Maximum Ratings

Parameter	Symbol	Rating	Unit
Input Voltage	V_{IN}	-0.3 to +7.0	V
EN Voltage	V_{EN}	-0.3 to V_{IN}	V
PGD Voltage	V_{PGD}	-0.3 to +7.0	V
FB, SS Voltage	V_{FB}, V_{SS}	-0.3 to V_{IN}	V
Maximum Junction Temperature	T_{jmax}	150	°C
Storage Temperature Range	T_{stg}	-55 to +150	°C

Caution 1: Operating the IC over the absolute maximum ratings may damage the IC. The damage can either be a short circuit between pins or an open circuit between pins and the internal circuitry. Therefore, it is important to consider circuit protection measures, such as adding a fuse, in case the IC is operated over the absolute maximum ratings.

Caution 2: Should by any chance the maximum junction temperature rating be exceeded the rise in temperature of the chip may result in deterioration of the properties of the chip. In case of exceeding this absolute maximum rating, design a PCB with thermal resistance taken into consideration by increasing board size and copper area so as not to exceed the maximum junction temperature rating.

Thermal Resistance^(Note 1)

Parameter	Symbol	Thermal Resistance (Typ)		Unit
		1s ^(Note 3)	2s2p ^(Note 4)	
VSON008X2020				
Junction to Ambient	θ_{JA}	181.90	47.90	°C/W
Junction to Top Characterization Parameter ^(Note 2)	Ψ_{JT}	20.00	7.00	°C/W

(Note 1) Based on JESD51-2A(Still-Air), using a BD9S209NUX-C Chip.

(Note 2) The thermal characterization parameter to report the difference between junction temperature and the temperature at the top center of the outside surface of the component package.

(Note 3) Using a PCB board based on JESD51-3.

(Note 4) Using a PCB board based on JESD51-5, 7.

Layer Number of Measurement Board	Material	Board Size
Single	FR-4	114.3 mm x 76.2 mm x 1.57 mmt

Top	
Copper Pattern	Thickness
Footprints and Traces	70 μ m

Layer Number of Measurement Board	Material	Board Size	Thermal Via ^(Note 5)	
			Pitch	Diameter
4 Layers	FR-4	114.3 mm x 76.2 mm x 1.6 mmt	1.20 mm	Φ 0.30 mm

Top		2 Internal Layers		Bottom	
Copper Pattern	Thickness	Copper Pattern	Thickness	Copper Pattern	Thickness
Footprints and Traces	70 μ m	74.2 mm x 74.2 mm	35 μ m	74.2 mm x 74.2 mm	70 μ m

(Note 5) This thermal via connect with the copper pattern of layers 1,2, and 4. The placement and dimensions obey a land pattern.

Recommended Operating Conditions

Parameter	Symbol	Min	Max	Unit
Input Voltage	V_{IN}	2.7	5.5	V
Operating Temperature	T_a	-40	+125	°C
Output Current	I_{OUT}	-	2	A
Output Voltage Setting	V_{OUT}	0.8 ^(Note 1)	V_{IN}	V
SW Minimum ON Time	t_{ON_MIN}	-	80	ns

(Note 1) Although the output voltage is configurable at 0.8 V and higher, it may be limited by the SW min ON pulse width. For the configurable range, refer to [2. Selection of Output Voltage Setting](#) in Selection of Components Externally Connected.

Electrical Characteristics (Unless otherwise specified Ta = Tj = -40 °C to +125 °C, V_{IN} = 5.0 V, V_{EN} = 5.0 V, the typical value is defined at Ta = Tj = +25 °C)

Parameter	Symbol	Min	Typ	Max	Unit	Conditions
VIN						
Shutdown Circuit Current	I _{SDN}	-	0	10	μA	V _{EN} = 0 V, Ta = 25 °C
Circuit Current	I _{CC}	250	400	550	μA	I _{OUT} = 0 mA Non-switching, Ta = 25 °C
UVLO Detection Voltage	V _{UVLO1}	2.30	2.45	2.60	V	V _{IN} Falling
UVLO Release Voltage	V _{UVLO2}	2.40	2.55	2.70	V	V _{IN} Rising
UVLO Hysteresis Voltage	V _{UVLO-HYS}	50	100	125	mV	
ENABLE						
EN Input Voltage High	V _{ENH}	1.0	-	V _{IN}	V	
EN Input Voltage Low	V _{ENL}	GND	-	0.4	V	
EN Input Current	I _{EN}	2.0	5.0	8.0	μA	V _{EN} = 5.0 V, Ta = 25 °C
Reference Voltage						
FB Pin Voltage	V _{FB}	0.788	0.800	0.812	V	(Note 1)
FB Input Current	I _{FB}	-	0	0.2	μA	V _{FB} = 0.8 V, Ta = 25 °C
Soft Start						
Soft Start Time	t _{SS}	0.5	1.0	2.0	ms	V _{IN} = 5.0 V, The SS Pin OPEN
		0.6	1.2	2.4	ms	V _{IN} = 3.3 V, The SS Pin OPEN
SS Charge Current	I _{SS}	-1.4	-1.0	-0.6	μA	
Switching Frequency						
Switching Frequency	f _{SW}	2.0	2.2	2.4	MHz	
Power Good						
PGD Falling (Fault) Voltage	V _{PGDTH_FF}	V _{FB} x 0.87	V _{FB} x 0.90	V _{FB} x 0.93	V	V _{FB} Falling
PGD Rising (Good) Voltage	V _{PGDTH_RG}	V _{FB} x 0.90	V _{FB} x 0.93	V _{FB} x 0.96	V	V _{FB} Rising
PGD Rising (Fault) Voltage	V _{PGDTH_RF}	V _{FB} x 1.07	V _{FB} x 1.10	V _{FB} x 1.13	V	V _{FB} Rising
PGD Falling (Good) Voltage	V _{PGDTH_FG}	V _{FB} x 1.04	V _{FB} x 1.07	V _{FB} x 1.10	V	V _{FB} Falling
PGD Output Leakage Current	I _{LEAKPGD}	-	0	2.0	μA	V _{PGD} = 5.0 V, Ta = 25 °C
PGD FET ON Resistance	R _{PGD}	30	60	120	Ω	
PGD Output Low Level Voltage	V _{PGDL}	0.03	0.06	0.12	V	I _{PGD} = 1.0 mA
Switch MOSFET						
High Side FET ON Resistance	R _{ONH}	80	150	250	mΩ	V _{IN} = 5.0 V
		90	175	280	mΩ	V _{IN} = 3.3 V
Low Side FET ON Resistance	R _{ONL}	55	95	150	mΩ	V _{IN} = 5.0 V
		60	100	160	mΩ	V _{IN} = 3.3 V
High Side FET Leakage Current	I _{LEAKSWH}	-	0	5.0	μA	V _{IN} = 5.5 V, V _{SW} = 0 V, Ta = 25 °C
Low Side FET Leakage Current	I _{LEAKSWL}	-	0	5.0	μA	V _{IN} = 5.5 V, V _{SW} = 5.5 V, Ta = 25 °C
SW Current of Over Current Protection ^(Note 2)	I _{OCP}	2.30	2.85	3.40	A	
SW Discharge Resistance	R _{DIS}	20	50	100	Ω	
SCP, OVP						
Short Circuit Protection Detection Voltage	V _{SCP}	0.48	0.56	0.64	V	V _{FB} Falling
Output Over Voltage Protection Detection Voltage	V _{OVP}	0.856	0.880	0.904	V	V _{FB} Rising

(Note 1) It is tested in a proprietary test mode that connects FB to the output of the error amplifier.

(Note 2) This is design value. Not production tested.

Typical Performance Curves

Unless otherwise specified $V_{IN} = V_{EN}$

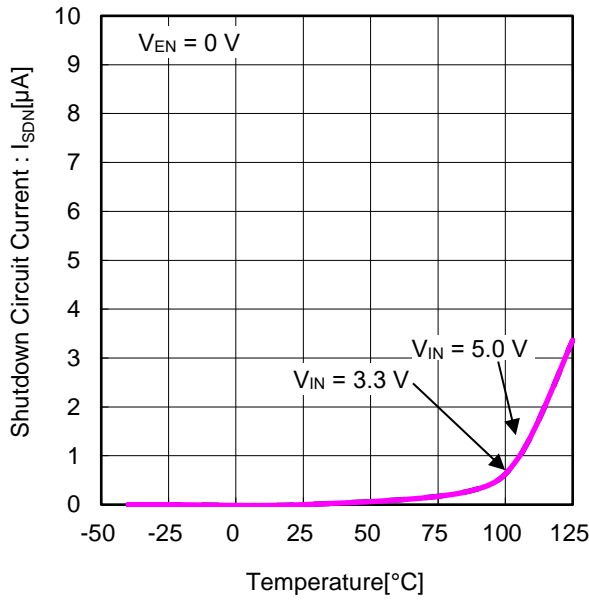

Figure 1. Shutdown Circuit Current vs Temperature

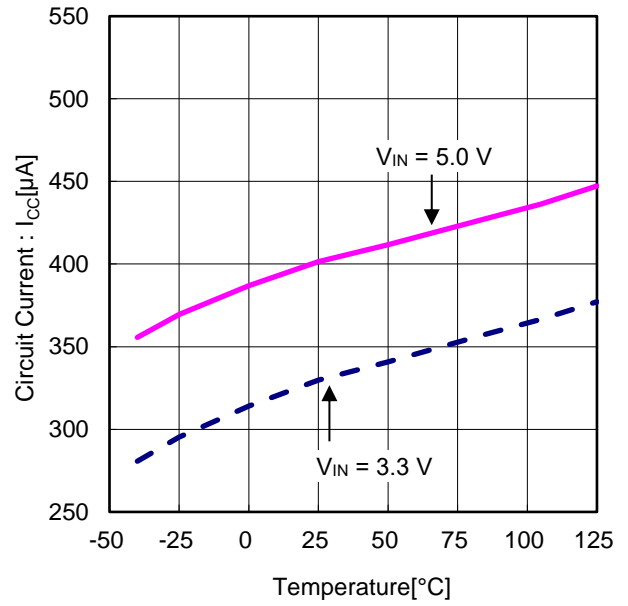

Figure 2. Circuit Current vs Temperature

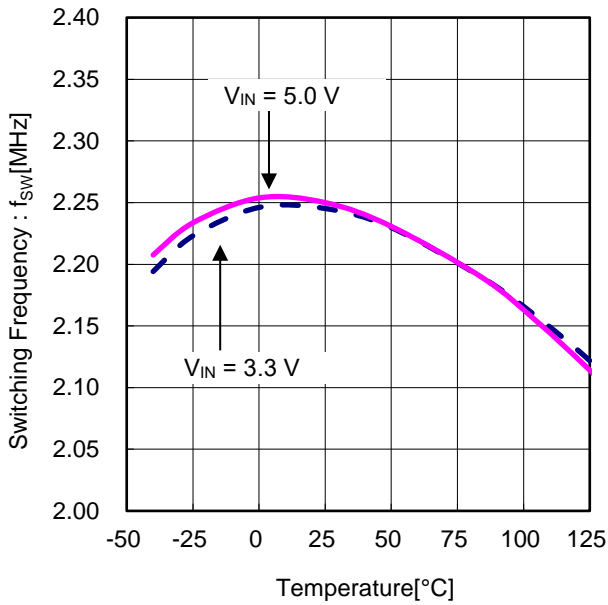

Figure 3. Switching Frequency vs Temperature

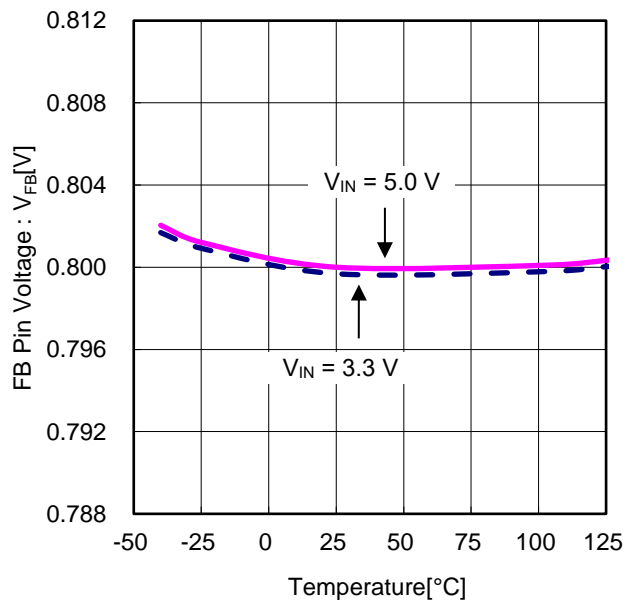

Figure 4. FB Pin Voltage vs Temperature

Typical Performance Curves – continued

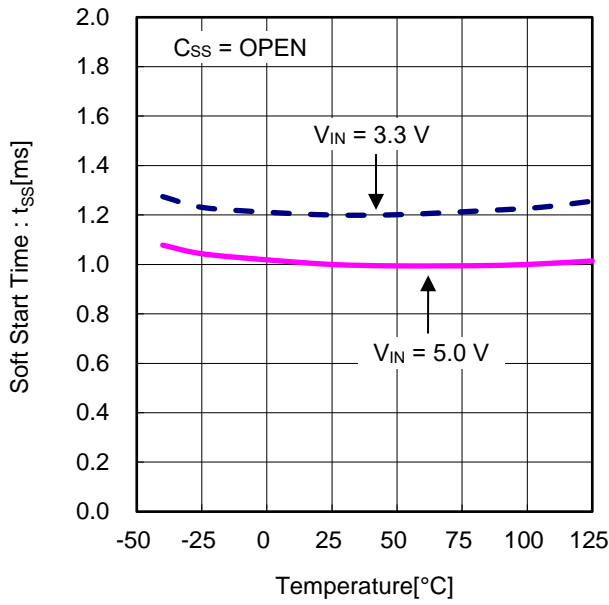

Figure 5. Soft Start Time vs Temperature

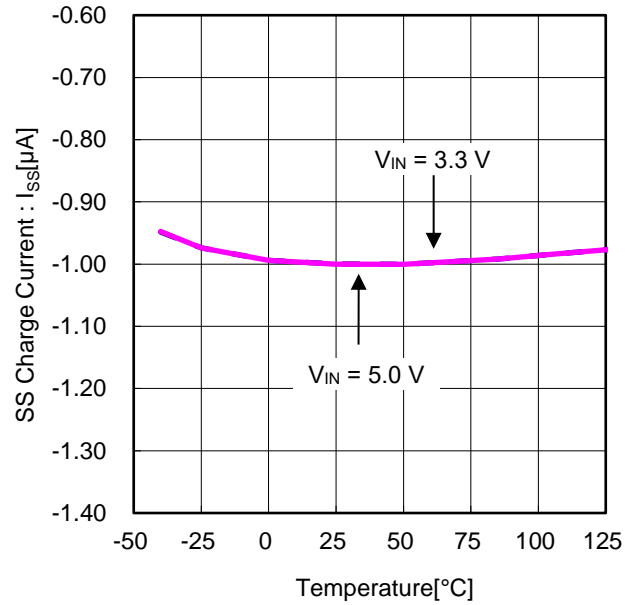

Figure 6. SS Charge Current vs Temperature

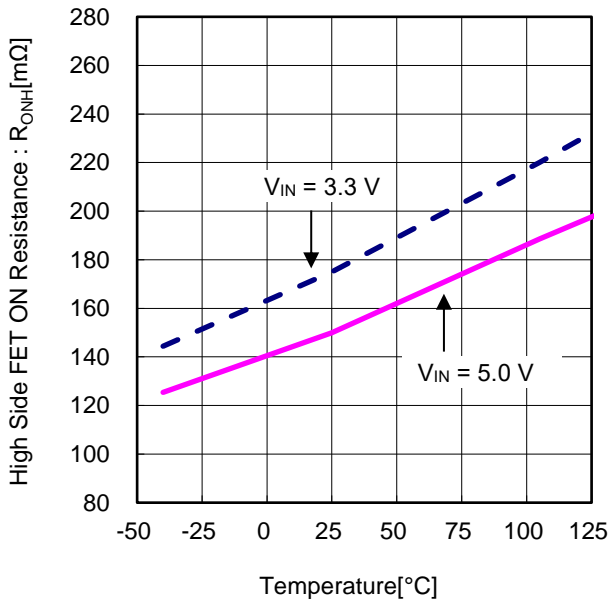

Figure 7. High Side FET ON Resistance vs Temperature

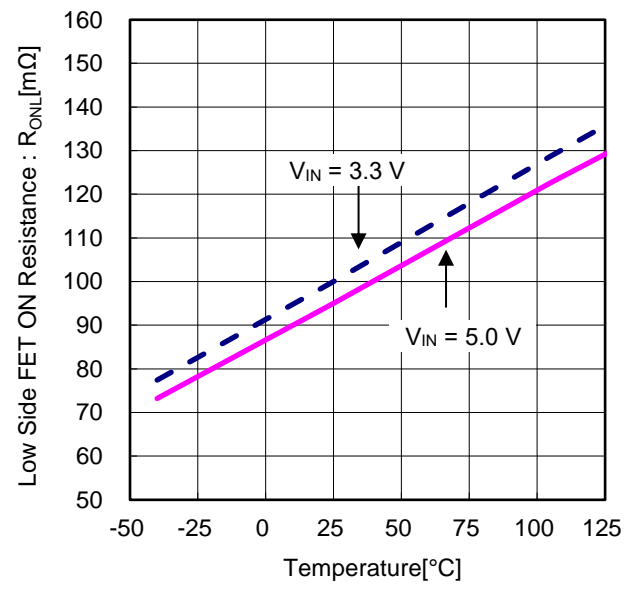

Figure 8. Low Side FET ON Resistance vs Temperature

Typical Performance Curves – continued

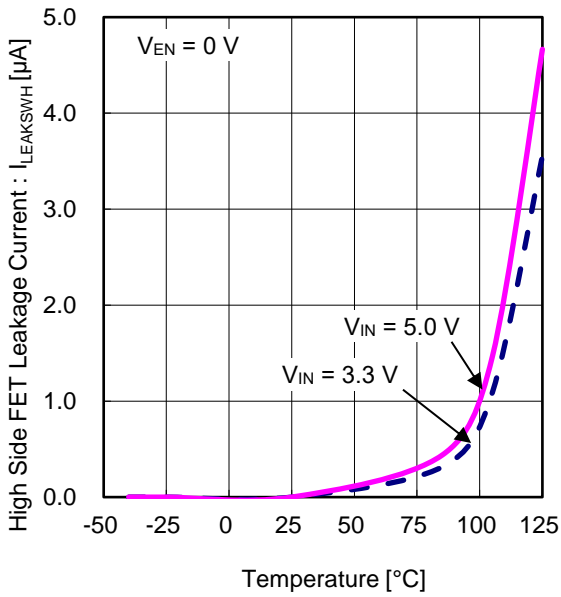

Figure 9. High Side FET Leakage Current vs Temperature

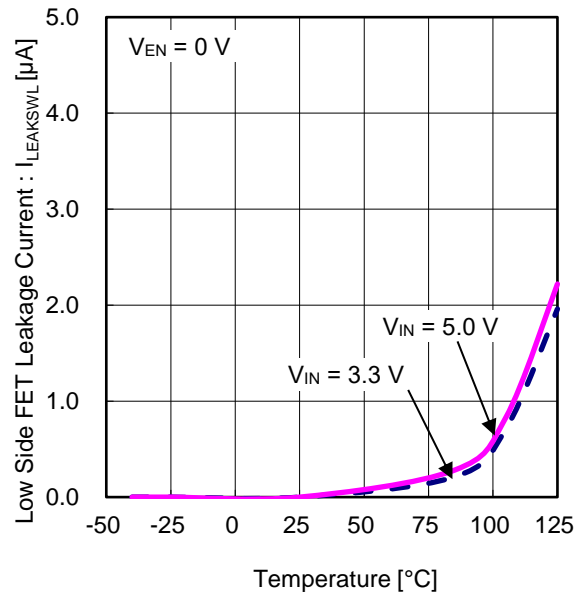

Figure 10. Low Side FET Leakage Current vs Temperature

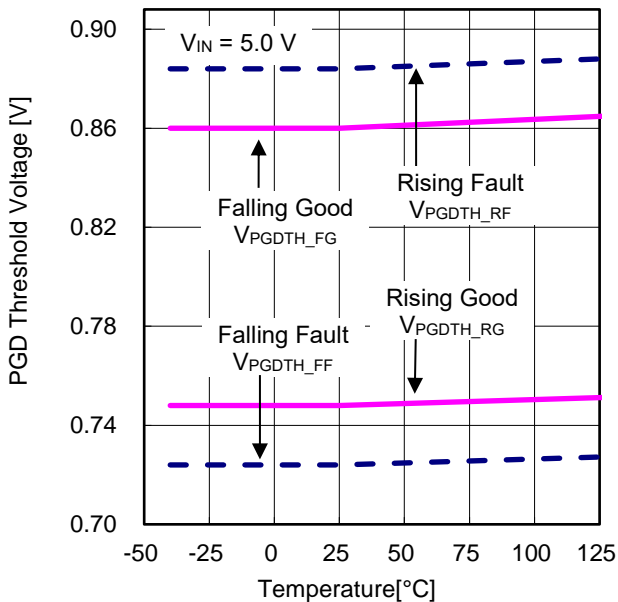

Figure 11. PGD Threshold Voltage vs Temperature

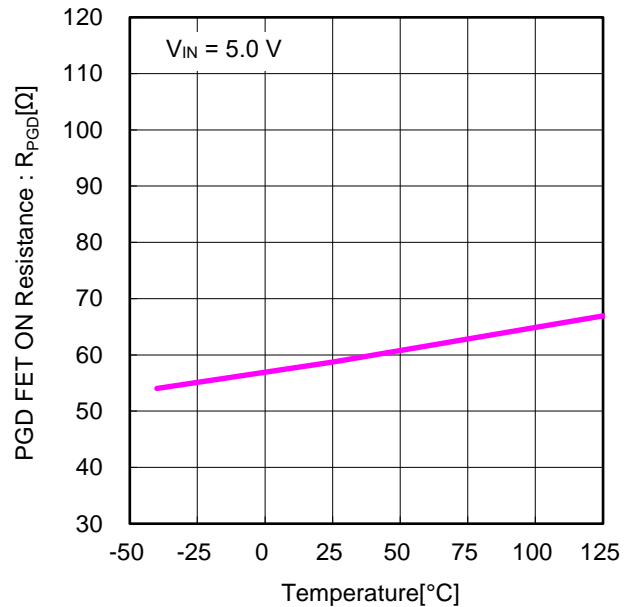

Figure 12. PGD FET ON Resistance vs Temperature

Typical Performance Curves – continued

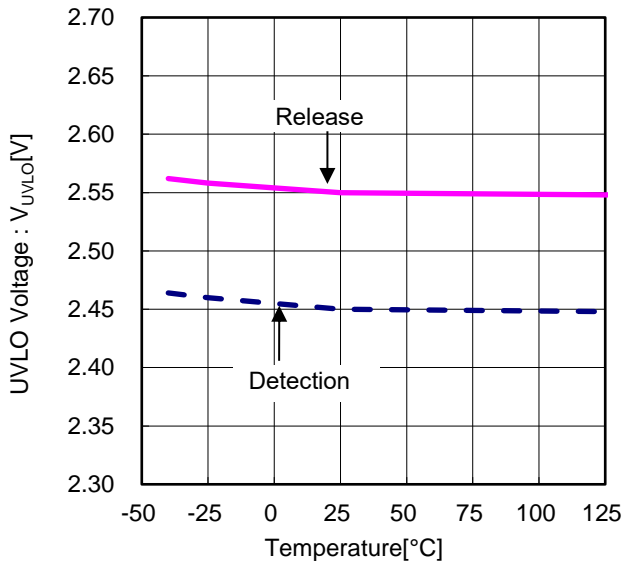

Figure 13. UVLO Voltage vs Temperature

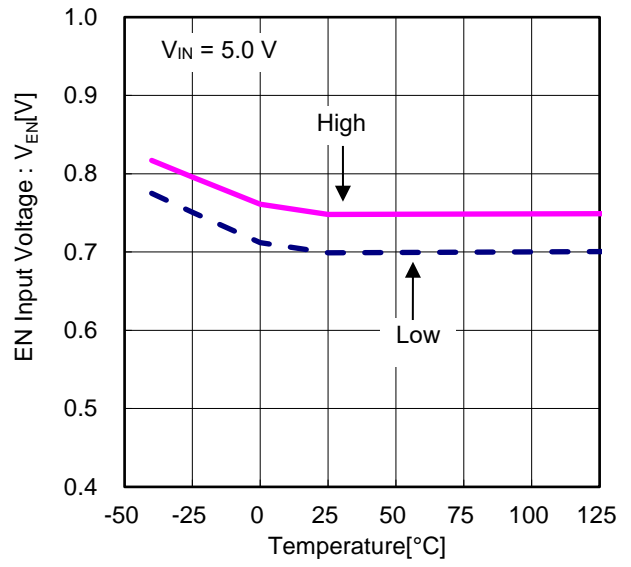

Figure 14. EN Input Voltage vs Temperature

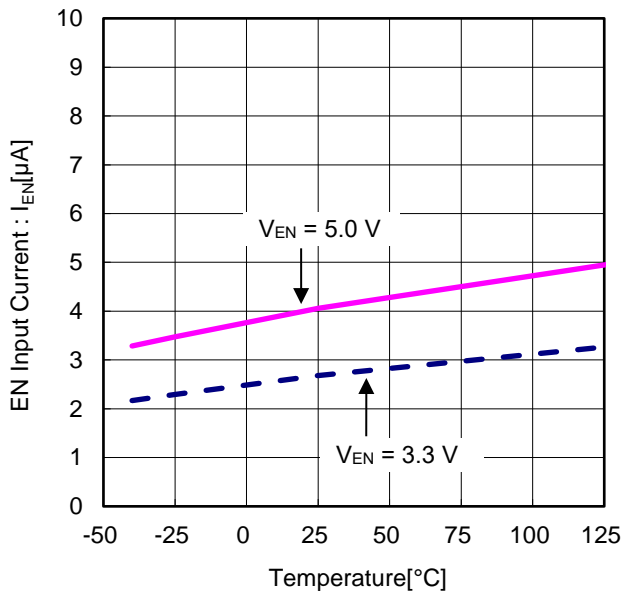

Figure 15. EN Input Current vs Temperature

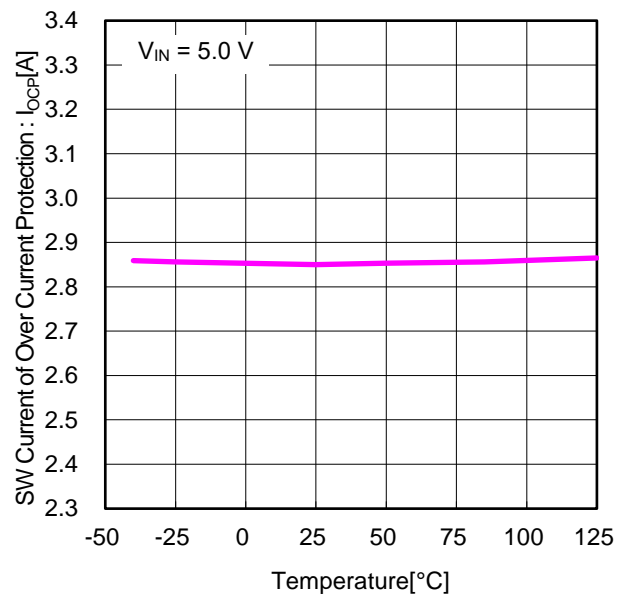

Figure 16. SW Current of Over Current Protection vs Temperature

Typical Performance Curves – continued

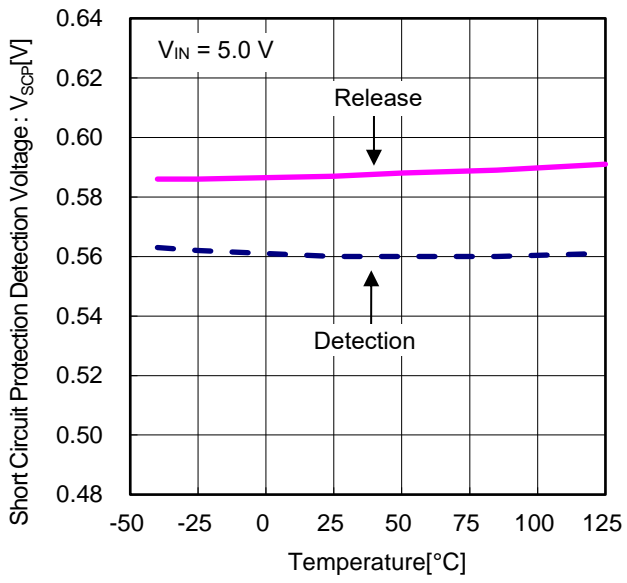

Figure 17. Short Circuit Protection Detection Voltage vs Temperature

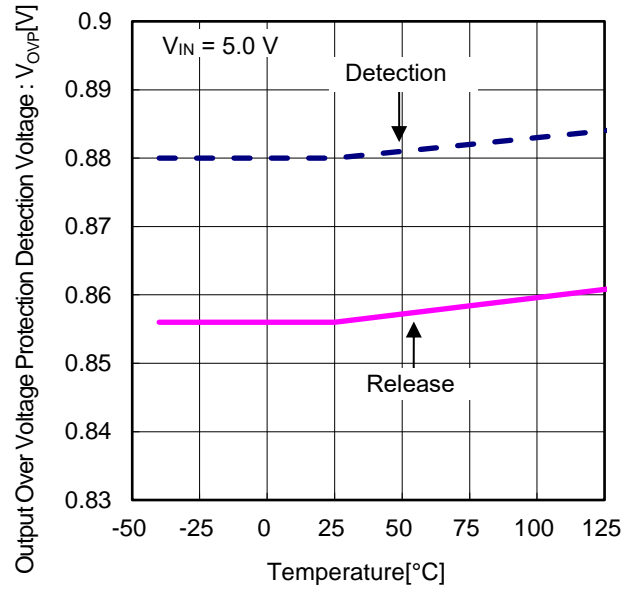

Figure 18. Output Over Voltage Protection Detection Voltage vs Temperature

Function Explanations

1. Enable Control

The device shutdown can be controlled by the voltage applied to the EN pin. When V_{EN} becomes 1.0 V or more, the internal circuit is activated and the device starts up with soft start. When V_{EN} becomes 0.4 V or less, the device is shutdown.

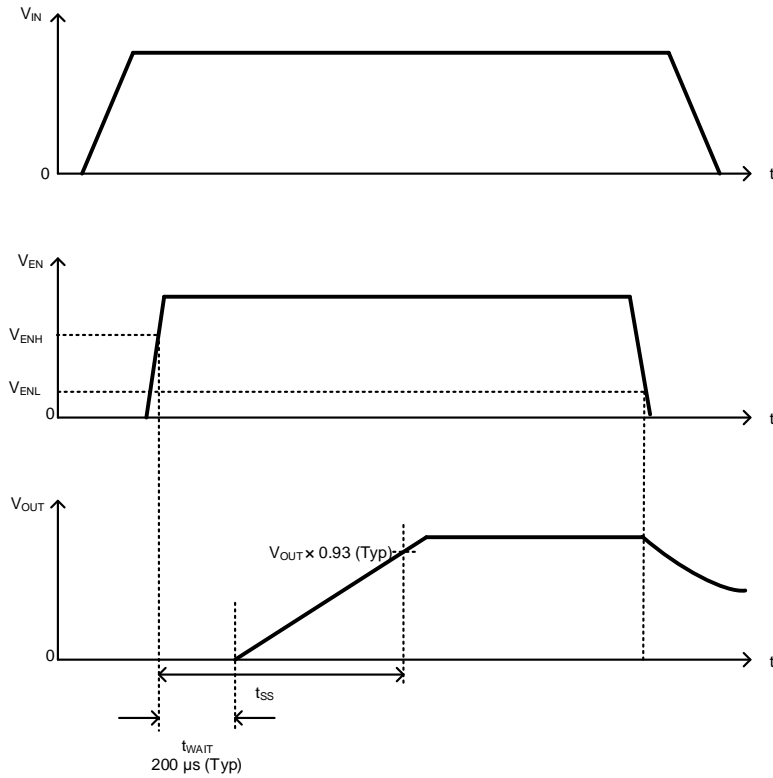

Figure 19. Enable ON/OFF Timing Chart

2. Power Good Output

When the FB pin voltage reaches 0.8 V (Typ) within $\pm 7\%$, the PGD pin open drain MOSFET turns OFF and the output turns high. There is a 3% hysteresis on the threshold voltage, so when the FB pin voltage reaches outside $\pm 10\%$ of 0.8 V (Typ), the PGD pin open drain MOSFET turns ON and the PGD pin is pulled down with impedance of 60 Ω (Typ). It is recommended to use a pull-up resistor of 2 k Ω to 100 k Ω for the power source. If an adjacent short with the EN pin is assumed, control by the EN signal may not be possible if the resistance value is reduced. Check the actual application thoroughly before deciding the resistance value. If the power good function is not used, connect the PGD pin to OPEN or GND.

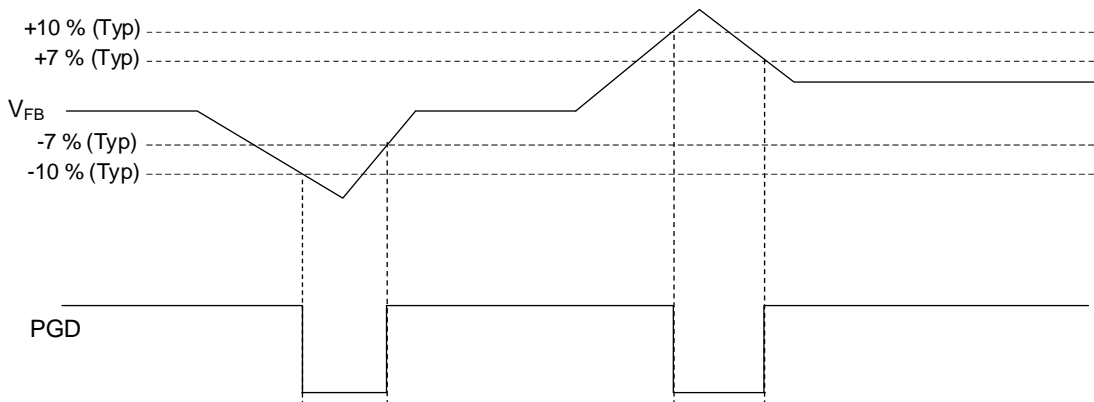

Figure 20. Power Good Timing Chart

Function Explanations – continued

3. Output Discharge Function

When even one of the following conditions is satisfied, output is discharged with 50 Ω (Typ) resistance through the SW pin.

- V_{EN} becomes 0.4 V or less
- V_{IN} becomes 2.45 V (Typ) or less (UVLO)
- V_{FB} becomes 0.56 V (Typ) or less and remains there for 1 ms (Typ) (SCP)
- V_{FB} becomes 0.88 V (Typ) or more (OVP)
- T_j becomes 175 $^{\circ}\text{C}$ (Typ) or more (TSD)

When all of the above conditions are released, output discharge is stopped.

4. Pre-bias Function

The device can start up without to sink large current from the output even when the output is pre-biased. For example, if the device is turned ON/OFF by the EN pin, the output is discharged with the resistor of 50 Ω (Typ) during the EN OFF section and the delay section t_{WAIT} of 200 μs (Typ) after restarting, but both output MOSFETs are turned off. After that, when the internal SS voltage reaches the high voltage 40 mV (Typ) than the internal FB voltage, the device starts switching and the output rises to the set voltage with soft start.

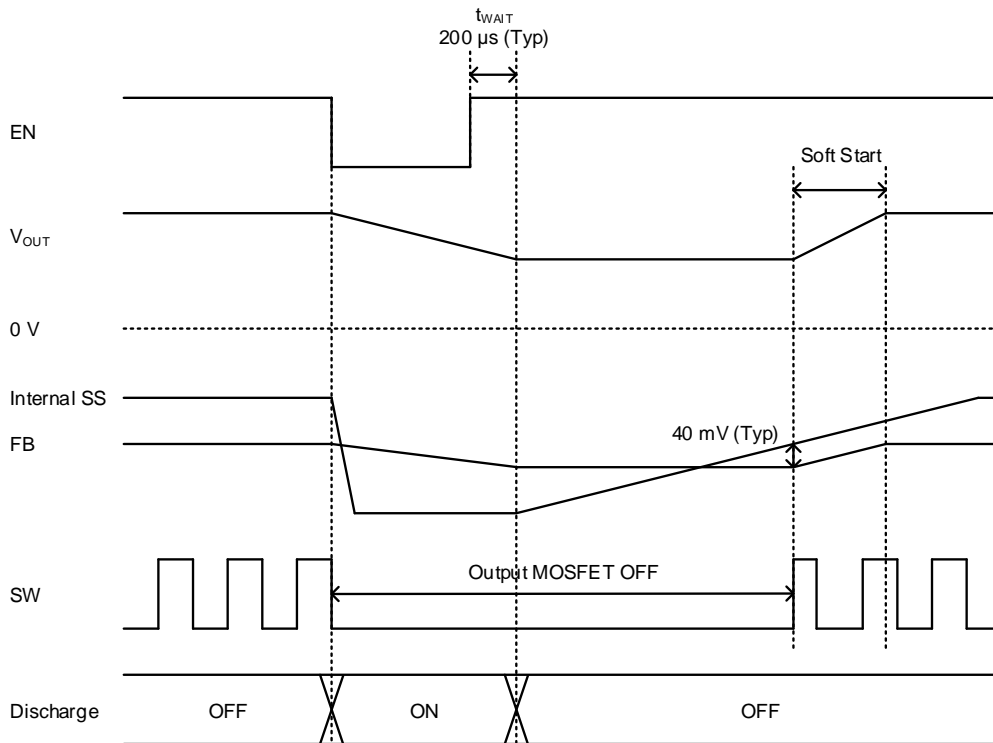

Figure 21. Pre-bias Timing Chart

Protection

1. Short Circuit Protection (SCP)

The Short Circuit Protection block compares the FB pin voltage with the internal reference voltage VREF. When the FB pin voltage has fallen to 0.56 V (Typ) or less and remained there for 1 ms (Typ), SCP stops the operation for 14 ms (Typ) and subsequently initiates a restart. This protection circuit is effective in preventing damage due to sudden and unexpected incidents. However, the device should not be used in applications characterized by continuous operation of the protection circuit (e.g. when a load that significantly exceeds the output current capability of the chip is connected at all times).

The EN Pin	The FB Pin	Short Circuit Protection	Short Circuit Protection Operation
1.0 V or more	$\leq 0.56 \text{ V (Typ)}$	Enabled	ON
	$\geq 0.60 \text{ V (Typ)}$		OFF
0.4 V or less	-	Disabled	OFF

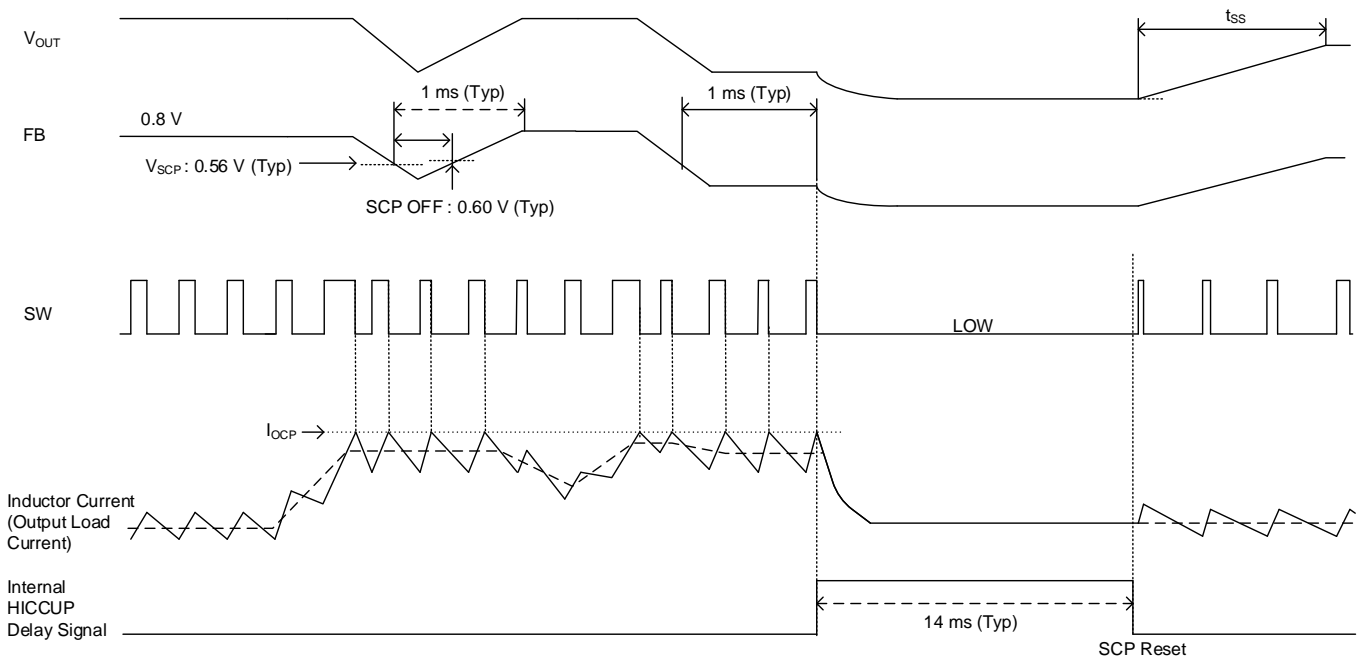

Figure 22. Short Circuit Protection (SCP) Timing Chart

2. Over Current Protection (OCP)

The Over Current Protection function operates by limiting the current that flows through High Side FET at each cycle of the switching frequency. This protection circuit is effective in preventing damage due to sudden and unexpected incidents. However, the device should not be used in applications characterized by continuous operation of the protection circuit (e.g. when a load that significantly exceeds the output current capability of the chip is connected at all times).

Protection – continued

3. Under Voltage Lockout Protection (UVLO)

It shuts down the device when the VIN pin falls to 2.45 V (Typ) or less. The threshold voltage has a hysteresis of 100 mV (Typ).

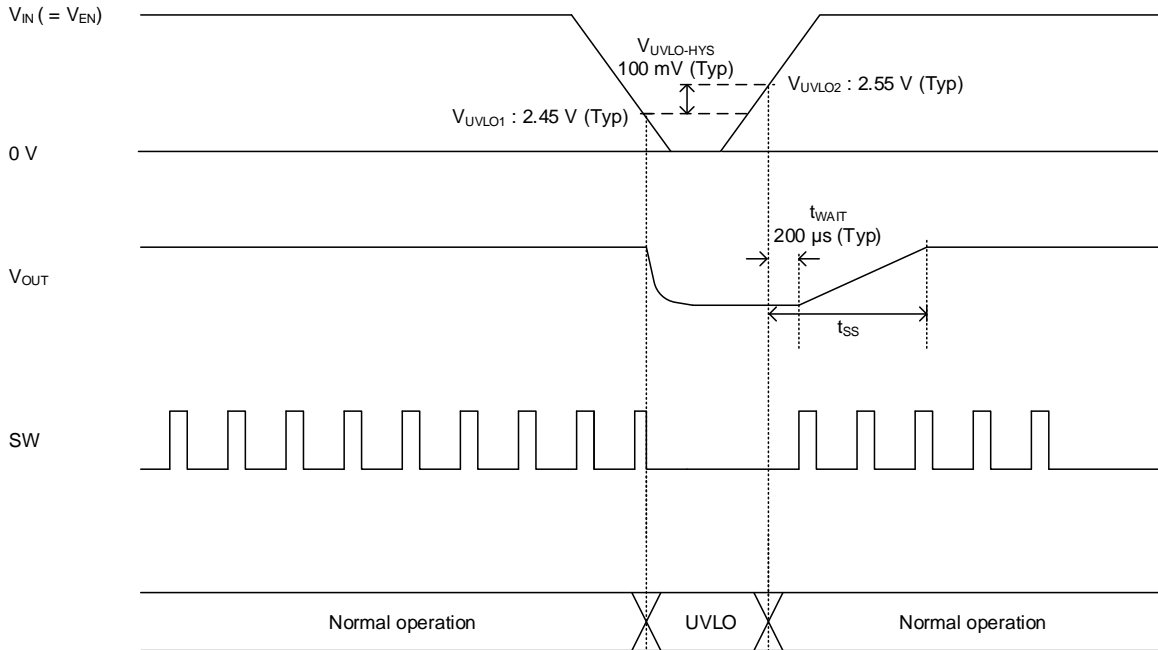

Figure 23. UVLO Timing Chart

4. Thermal Shutdown (TSD)

This is the thermal shutdown circuit that prevents heat damage to the IC. Normal operation should always be within the IC's maximum junction temperature rating. However, if the rating is exceeded for a continued period and the junction temperature (T_j) rises to 175 °C (Typ), the TSD circuit activates and the output MOSFETs turn OFF. When the T_j falls below the TSD threshold, the circuits are automatically restored to normal operation. Note that the TSD circuit operates in a situation that exceeds the absolute maximum ratings and therefore, under no circumstances, should the TSD circuit be used in a set design or for any purpose other than protecting the IC from heat damage.

5. Over Voltage Protection (OVP)

The device incorporates an over voltage protection circuit to minimize the output voltage overshoot when recovering from strong load transients or output fault conditions. If the FB pin voltage becomes over or equal to 0.88 V (Typ), which is Output Over Voltage Protection Detection Voltage, the MOSFETs on the output stage are turned OFF to prevent the increase in the output voltage. After the detection, the switching operation resumes if the output decreases, the over voltage state is released, and FB pin voltage reaches 0.8 V (Typ). Output Over Voltage Protection Detection Voltage and release voltage have a hysteresis of 3 %.

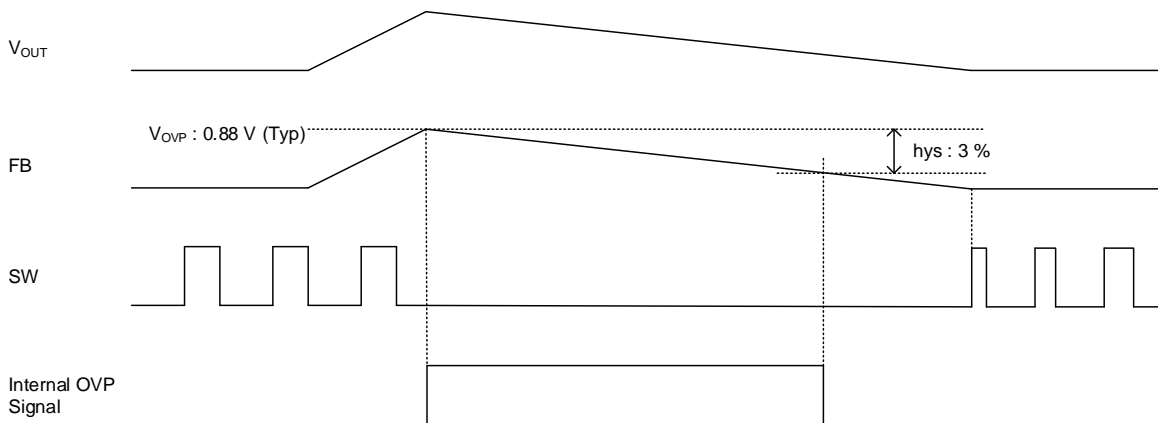

Figure 24. OVP Timing Chart

Selection of Components Externally Connected

Contact us if not use the recommended constant in this section.

Necessary parameters in designing the power supply are as follows:

Table 1. Application Specification

Parameter	Symbol	Example Value
Input Voltage	V_{IN}	5.0 V
Output Voltage	V_{OUT}	1.2 V (Typ)
Switching Frequency	f_{sw}	2.2 MHz (Typ)
Output Ripple Current	ΔI_L	0.61 A
Output Capacitor	C_{OUT}	10 μ F
Soft Start Time	t_{ss}	8.55 ms (Typ)
Maximum Output Current	I_{OUTMAX}	2.0 A

Application Example

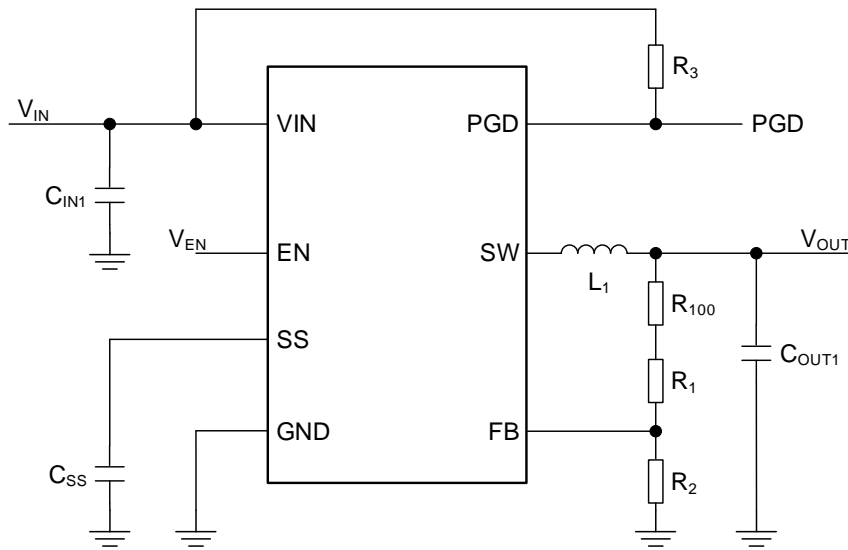

Figure 25. Application Circuit

1. Switching Frequency

The switching frequency f_{sw} is fixed at 2.2 MHz (Typ) inside the IC.

2. Selection of Output Voltage Setting

The output voltage value can be set by the feedback resistance ratio.

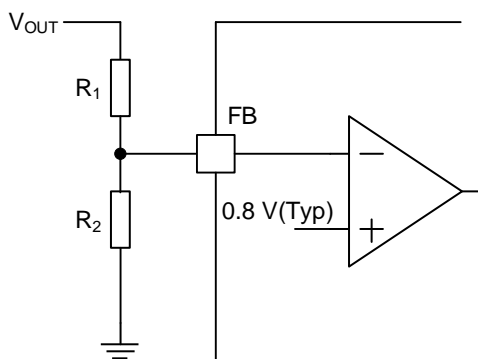

$$V_{OUT} = \frac{R_1 + R_2}{R_2} \times 0.8 \text{ [V]}$$

※ SW Minimum ON Time that BD9S209NUX-C can output stably in the entire load range is 80 ns. Use this value to calculate the input and output conditions that satisfy the following equation.

$$80 \text{ [ns]} \leq \frac{V_{OUT}}{V_{IN} \times f_{SW}}$$

Figure 26. Feedback Resistor Circuit

Selection of Components Externally Connected – continued

3. Selection of Input Capacitor

Use ceramic type capacitor for the input capacitor C_{IN1} . C_{IN1} is used to suppress the input ripple noise and this capacitor is effective by being placed as close as possible to the V_{IN} pin. Set the capacitor value for C_{IN1} so that it does not fall to 4.7 μF against the capacitor value variances, temperature characteristics, DC bias characteristics, aging characteristics, and etc. Use components which are comparatively same with the components used in “[Application Example](#)”. Moreover, factors like the PCB layout and the position of the capacitor may lead to IC malfunction. Refer to “[PCB Layout Design](#)”. In addition, the capacitor with value 0.1 μF can be added to suppress the high frequency noise as an option.

4. Selection of Output LC Filter

In order to supply a continuous current to the load, the DC/DC converter requires an LC filter for smoothing the output voltage. Use the inductor with value 0.68 μH to 1.0 μH .

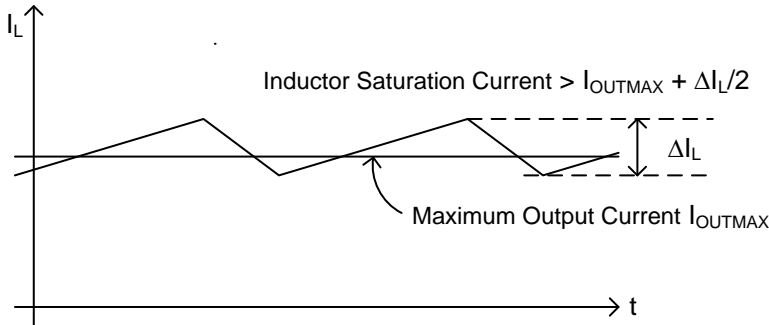

Figure 27. Waveform of Current through Inductor

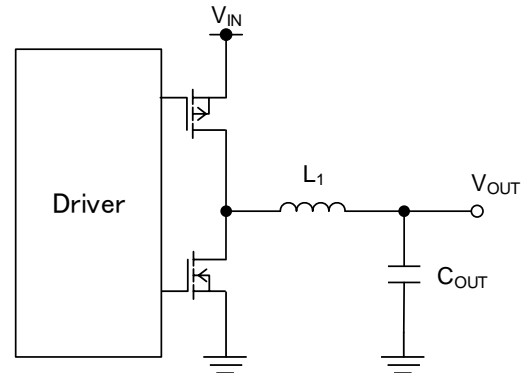

Figure 28. Output LC Filter Circuit

Inductor ripple current ΔI_L can be represented by the following equation.

$$\Delta I_L = V_{OUT} \times (V_{IN} - V_{OUT}) \times \frac{1}{V_{IN} \times f_{SW} \times L_1} = 610 \text{ [mA]}$$

where:

V_{IN} is the 5.0 V.

V_{OUT} is the 1.2 V.

L_1 is the 0.68 μH .

f_{SW} is the 2.2 MHz (Switching Frequency).

The rated current of the inductor must be larger than the sum of the maximum output current and 1/2 of the inductor ripple current ΔI_L .

Use ceramic type capacitor for the output capacitor C_{OUT} . The capacitance value of C_{OUT} is recommended in the range between 10 μF and 22 μF . C_{OUT} affects the output ripple voltage characteristics. C_{OUT} must satisfy the required ripple voltage characteristics.

The output ripple voltage can be represented by the following equation.

$$\Delta V_{RPL} = \Delta I_L \times \left(R_{ESR} + \frac{1}{8 \times C_{OUT} \times f_{SW}} \right) \text{ [V]}$$

where:

R_{ESR} is the Equivalent Series Resistance (ESR) of the output capacitor.

The output ripple voltage ΔV_{RPL} can be represented by the following equation.

$$\Delta V_{RPL} = 0.610 \text{ A} \times \left(10 \text{ m}\Omega + \frac{1}{8 \times 10 \mu\text{F} \times 2.2 \text{ MHz}} \right) = 9.57 \text{ [mV]}$$

where:

C_{OUT} is the 10 μF .

R_{ESR} is the 10 m Ω .

4. Selection of Output LC Filter – continued

In addition, for the total value of capacitance in the output line C_{OUT} (Max), need to satisfy the value obtained by the following equation.

$$C_{OUT(Max)} < \frac{(t_{SS(Min)} - 200 \mu s) \times (I_{OCP(Min)} - I_{SWSTART})}{V_{OUT}} \text{ [F]}$$

where:

- I_{SWSTART} is the maximum output current during startup.
- I_{OCP(Min)} is the minimum OCP operation SW current 2.3 A.
- t_{SS(Min)} is the minimum Soft Start Time t_{SS} ([Electrical Characteristics](#)).
- V_{OUT} is the output voltage.

Startup failure may happen if the limits from the above-mentioned are exceeded. Especially if the capacitance value is large, over current protection may be activated by the inrush current at startup and prevented to turn on the output. Confirm this on the actual application.

Stable transient response and the loop is dependent to C_{OUT}. Actually, characteristics vary depending on PCB layout, arrangement of wiring, kinds of parts used and use conditions (temperature, etc.). Be sure to check stability and responsiveness with the actual application.

5. Selection of Soft Start Capacitor

Turning the EN pin signal high activates the soft start function. This causes the output voltage to rise gradually while the current at startup is placed under control. This allows the prevention of output voltage overshoot and inrush current. The rise time t_{SS_EXT} depends on the value of the capacitor connected to the SS pin. The capacitance value should be set in the range between 4700 pF and 0.1 μF.

$$t_{SS_EXT} = \frac{(C_{SS} \times 0.8)}{I_{SS}} + t_{OFFSET} \text{ [s]}$$

$$t_{OFFSET} = \frac{(C_{SS} \times 0.04)}{I_{SS}} + 150 \times 10^{-6} \text{ [s]}$$

where:

- t_{SS_EXT} is the Soft Start Time.
- t_{OFFSET} is the Internal Delay Time.
- C_{SS} is the Capacitor connected to the SS pin.
- I_{SS} is the SS Charge Current 1.0 μA (Typ).

With C_{SS} = 0.01 μF

$$t_{SS_EXT} = \frac{(0.01 \mu F \times 0.8)}{1.0 \mu A} + \frac{(0.01 \mu F \times 0.04)}{1.0 \mu A} + 150 \times 10^{-6} = 0.00855 = 8.55 \text{ [ms]}$$

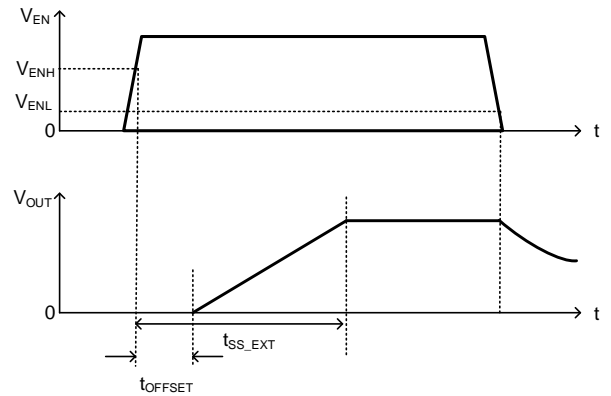

Figure 29. Soft Start Timing Chart

Turning the EN pin High without connecting capacitor to the SS pin and keeping the SS pin either OPEN condition or 10 kΩ to 100 kΩ pull up condition to power source, the output rises in 1 ms (Typ).

Recommended Parts Manufacturer List

Shown below is the list of the recommended parts manufacturers for reference.

Table 2. recommended parts manufacturers

Type	Manufacturer	URL
Ceramic capacitor	Murata	www.murata.com
Ceramic capacitor	TDK	product.tdk.com
Inductor	Coilcraft	www.coilcraft.com
Inductor	Cyntec	www.cyntec.com
Inductor	Murata	www.murata.com
Inductor	Sumida	www.sumida.com
Inductor	TDK	product.tdk.com
Resistor	ROHM	www.rohm.com

Application Example 1

Table 3. Specification Example 1

Parameter	Symbol	Example Value
Product Name	IC	BD9S209NUX-C
Input Voltage	V_{IN}	5.0 V, 3.3 V
Output Voltage	V_{OUT}	1.0 V
Soft Start Time	t_{SS}	1.0 ms (Typ)
Maximum Output Current	I_{OUTMAX}	2.0 A
Operation Temperature Range	T_a	-40 °C to +125 °C

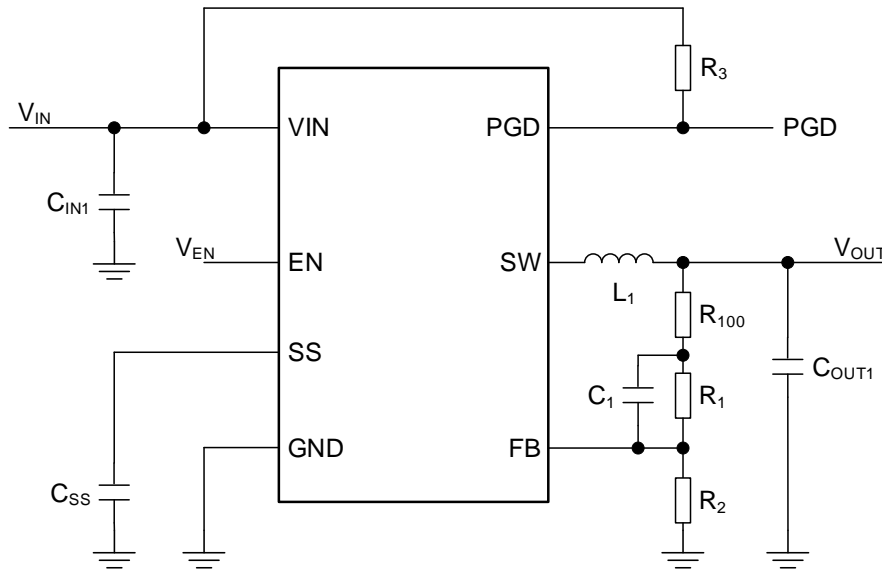

Figure 30. Measurement Circuit 1

Table 4. Parts List 1

No	Package	Parameters	Part Name (Series)	Type	Manufacturer
L ₁	2520	0.68 μH	DFE252012PD-R68M	Inductor	Murata
C _{OUT1}	2012	10 μF, X7R, 10 V	GCM21BR71A106KE21	Ceramic Capacitor	Murata
C _{IN1}	2012	10 μF, X7R, 10 V	GCM21BR71A106KE21	Ceramic Capacitor	Murata
R ₁₀₀	-	SHORT	-	-	-
R ₁	1005	7.5 kΩ, 1 %, 1/16 W	MCR01MZPF7501	Chip Resistor	ROHM
R ₂	1005	30 kΩ, 1 %, 1/16 W	MCR01MZPF3002	Chip Resistor	ROHM
R ₃	1005	100 kΩ, 1 %, 1/16 W	MCR01MZPF1003	Chip Resistor	ROHM
C _{SS}	-	-	-	-	-
C ₁	1005	100 pF, CH, 50 V	GCM1552C1H101JA01	Ceramic Capacitor	Murata

Characteristic Data (Application Examples 1)

$V_{IN} = V_{EN}$, $T_a = 25\text{ }^\circ\text{C}$

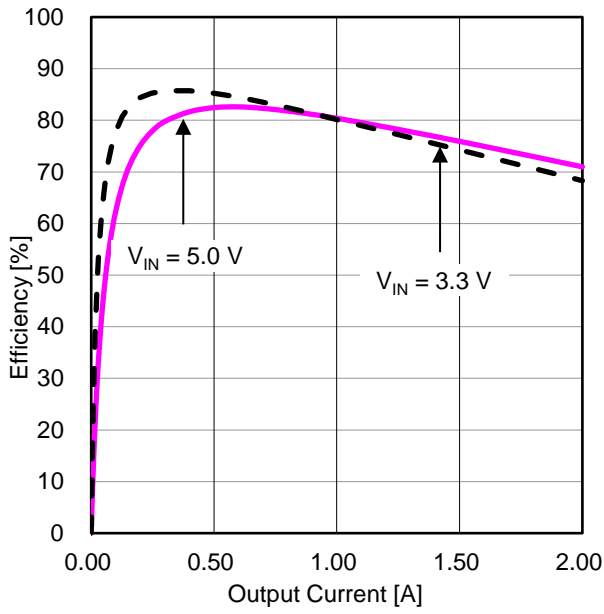

Figure 31. Efficiency vs Output Current

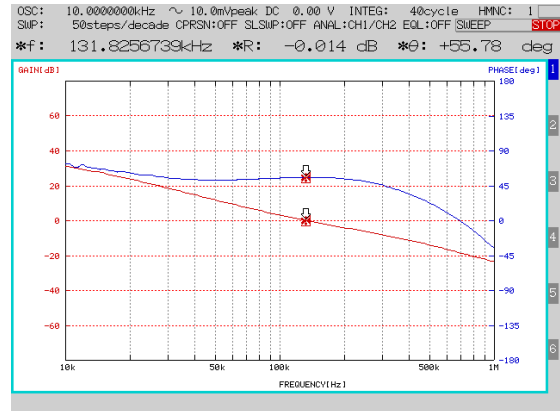

Figure 32. Frequency Characteristics ($I_{OUT} = 0.5\text{ A}$)

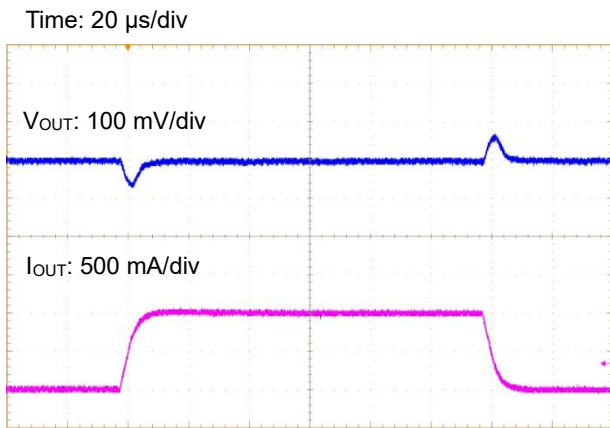

Figure 33. Load Transient Response ($I_{OUT} = 0\text{ A} \leftrightarrow 1\text{ A}$)

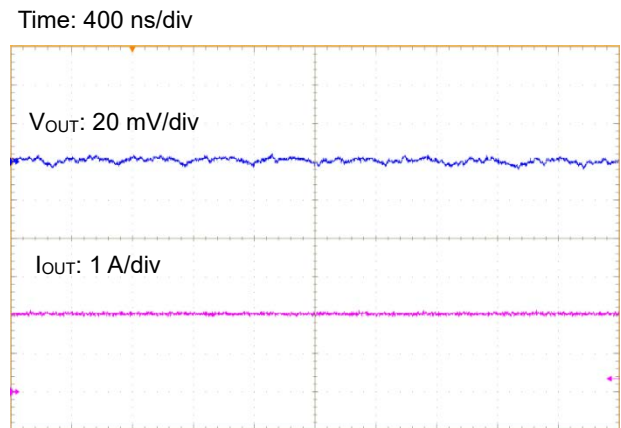

Figure 34. Output Ripple Voltage ($I_{OUT} = 2\text{ A}$)

Application Example 2

Table 5. Specification Example 2

Parameter	Symbol	Example Value
Product Name	IC	BD9S209NUX-C
Input Voltage	V_{IN}	5.0 V, 3.3 V
Output Voltage	V_{OUT}	1.2 V
Soft Start Time	t_{SS}	1.0 ms (Typ)
Maximum Output Current	I_{OUTMAX}	2.0 A
Operation Temperature Range	T_a	-40 °C to +125 °C

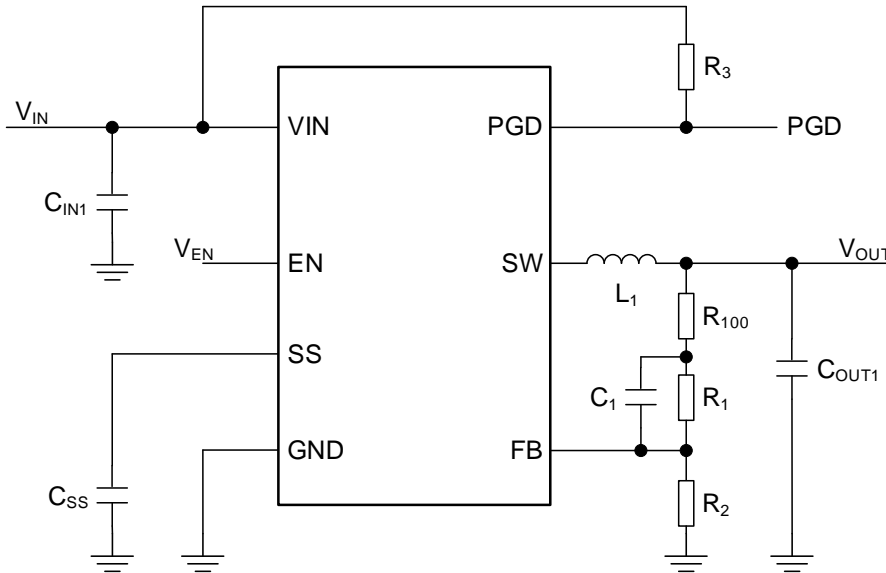

Figure 35. Measurement Circuit 2

Table 6. Parts List 2

No	Package	Parameters	Part Name (Series)	Type	Manufacturer
L ₁	2520	0.68 μH	DFE252012PD-R68M	Inductor	Murata
C _{OUT1}	2012	10 μF, X7R, 10 V	GCM21BR71A106KE21	Ceramic Capacitor	Murata
C _{IN1}	2012	10 μF, X7R, 10 V	GCM21BR71A106KE21	Ceramic Capacitor	Murata
R ₁₀₀	-	SHORT	-	-	-
R ₁	1005	10 kΩ, 1 %, 1/16 W	MCR01MZPF1002	Chip Resistor	ROHM
R ₂	1005	20 kΩ, 1 %, 1/16 W	MCR01MZPF2002	Chip Resistor	ROHM
R ₃	1005	100 kΩ, 1 %, 1/16 W	MCR01MZPF1003	Chip Resistor	ROHM
C _{SS}	-	-	-	-	-
C ₁	1005	100 pF, CH, 50 V	GCM1552C1H101JA01	Ceramic Capacitor	Murata

Characteristic Data (Application Examples 2)

$V_{IN} = V_{EN}$, $T_a = 25\text{ }^\circ\text{C}$

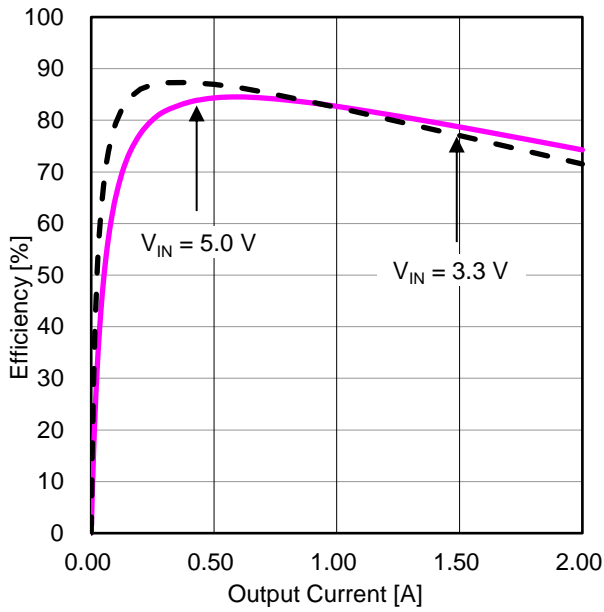

Figure 36. Efficiency vs Output Current

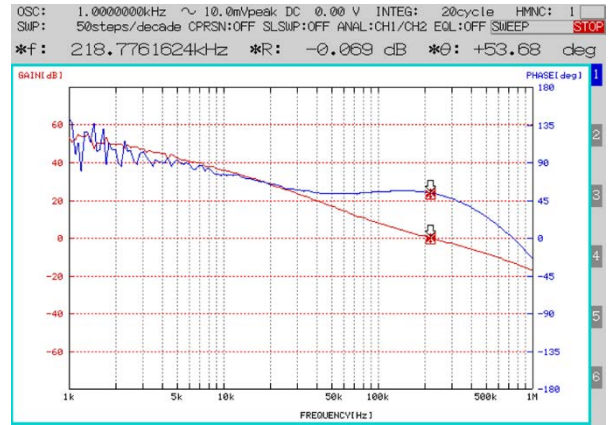

Figure 37. Frequency Characteristics ($I_{OUT} = 0.5\text{ A}$)

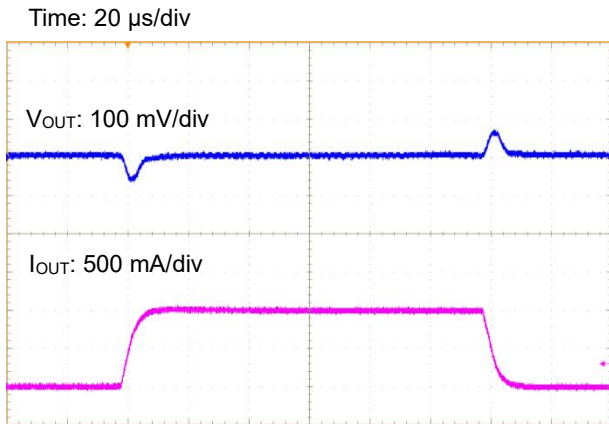

Figure 38. Load Transient Response ($I_{OUT} = 0\text{ A} \leftrightarrow 1\text{ A}$)

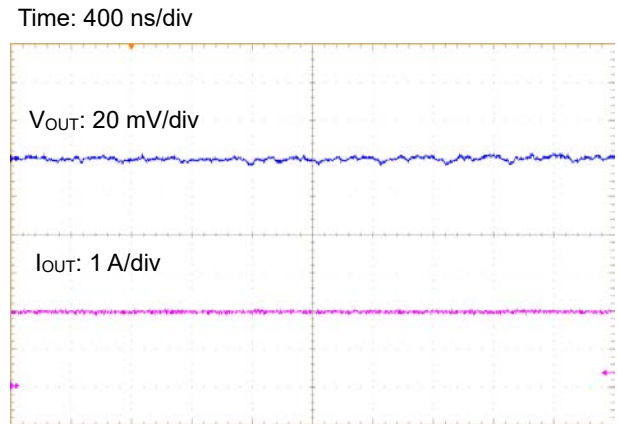

Figure 39. Output Ripple Voltage ($I_{OUT} = 2\text{ A}$)

Application Example 3

Table 7. Specification Example 3

Parameter	Symbol	Example Value
Product Name	IC	BD9S209NUX-C
Input Voltage	V_{IN}	5.0 V, 3.3 V
Output Voltage	V_{OUT}	1.5 V
Soft Start Time	t_{SS}	1.0 ms (Typ)
Maximum Output Current	I_{OUTMAX}	2.0 A
Operation Temperature Range	T_a	-40 °C to +125 °C

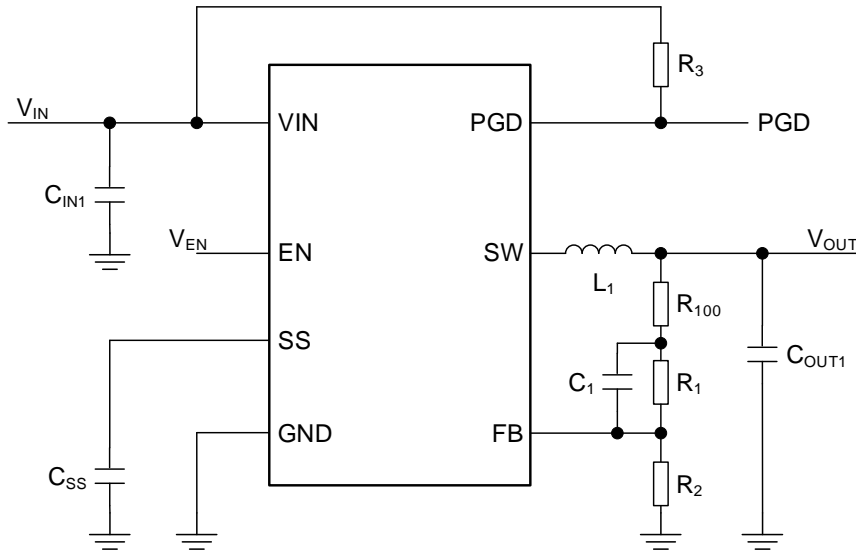

Figure 40. Measurement Circuit 3

Table 8. Parts List 3

No	Package	Parameters	Part Name (Series)	Type	Manufacturer
L ₁	2520	0.68 μH	DFE252012PD-R68M	Inductor	Murata
C _{OUT1}	2012	10 μF, X7R, 10 V	GCM21BR71A106KE21	Ceramic Capacitor	Murata
C _{IN1}	2012	10 μF, X7R, 10 V	GCM21BR71A106KE21	Ceramic Capacitor	Murata
R ₁₀₀	-	SHORT	-	-	-
R ₁	1005	16 kΩ, 1 %, 1/16 W	MCR01MZPF1602	Chip Resistor	ROHM
R ₂	1005	18 kΩ, 1 %, 1/16 W	MCR01MZPF1802	Chip Resistor	ROHM
R ₃	1005	100 kΩ, 1 %, 1/16 W	MCR01MZPF1003	Chip Resistor	ROHM
C _{SS}	-	-	-	-	-
C ₁	1005	100 pF, CH, 50 V	GCM1552C1H101JA01	Ceramic Capacitor	Murata

Characteristic Data (Application Examples 3)

$V_{IN} = V_{EN}$, $T_a = 25\text{ }^\circ\text{C}$

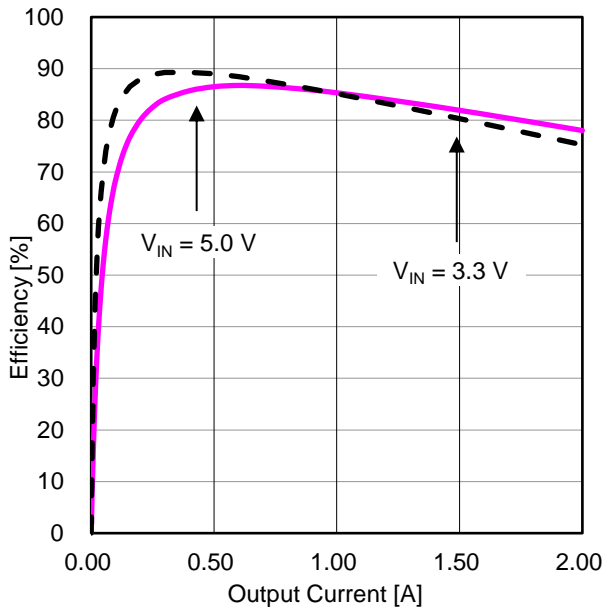

Figure 41. Efficiency vs Output Current

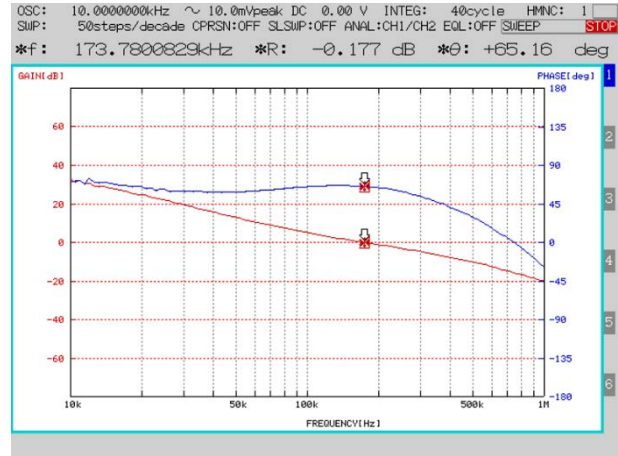

Figure 42. Frequency Characteristics ($I_{OUT} = 0.5\text{ A}$)

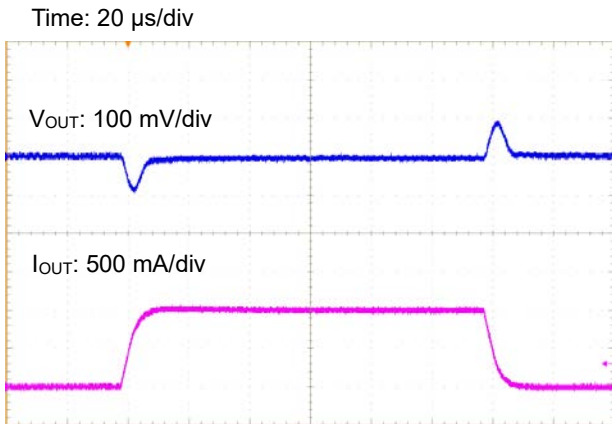

Figure 43. Load Transient Response ($I_{OUT} = 0\text{ A} \leftrightarrow 1\text{ A}$)

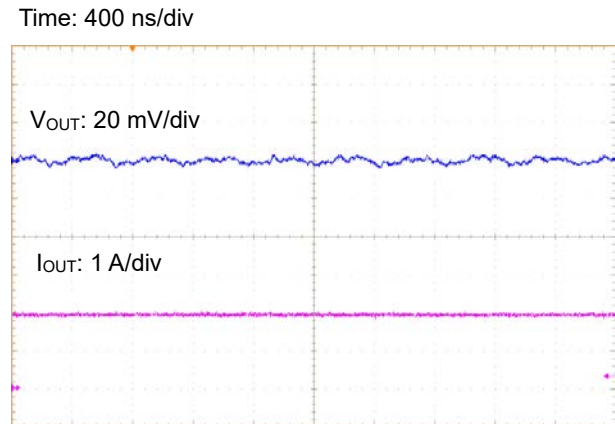

Figure 44. Output Ripple Voltage ($I_{OUT} = 2\text{ A}$)

Application Example 4

Table 9. Specification Example 4

Parameter	Symbol	Example Value
Product Name	IC	BD9S209NUX-C
Input Voltage	V_{IN}	5.0 V, 3.3 V
Output Voltage	V_{OUT}	1.8 V
Soft Start Time	t_{SS}	1.0 ms (Typ)
Maximum Output Current	I_{OUTMAX}	2.0 A
Operation Temperature Range	T_a	-40 °C to +125 °C

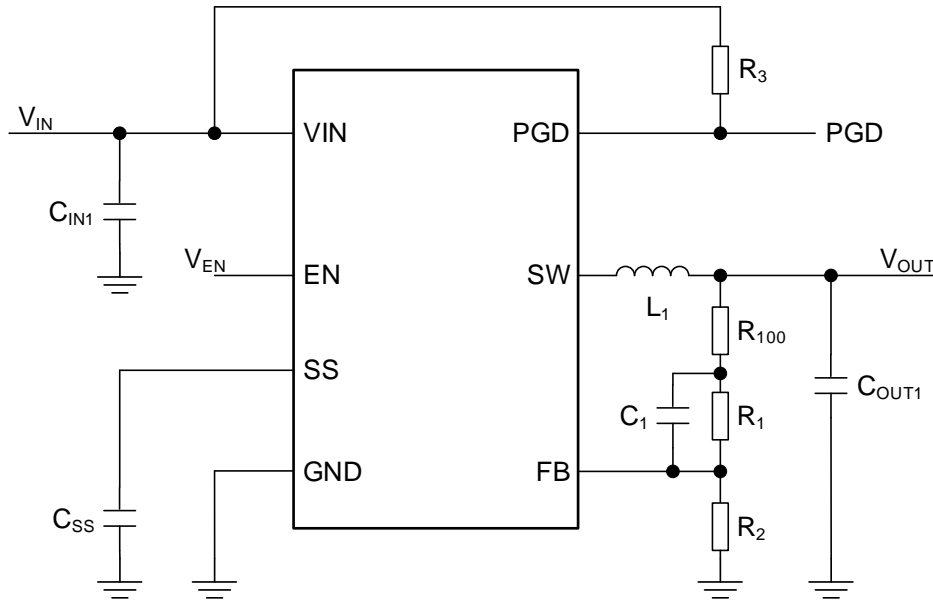

Figure 45. Measurement Circuit 4

Table 10. Parts List 4

No	Package	Parameters	Part Name (Series)	Type	Manufacturer
L ₁	2520	1.0 μH	TFM252012ALMA1R0M	Inductor	TDK
C _{OUT1}	2012	10 μF, X7R, 10 V	GCM21BR71A106KE21	Ceramic Capacitor	Murata
C _{IN1}	2012	10 μF, X7R, 10 V	GCM21BR71A106KE21	Ceramic Capacitor	Murata
R ₁₀₀	-	SHORT	-	-	-
R ₁	1005	30 kΩ, 1 %, 1/16 W	MCR01MZPF3002	Chip Resistor	ROHM
R ₂	1005	24 kΩ, 1 %, 1/16 W	MCR01MZPF2402	Chip Resistor	ROHM
R ₃	1005	100 kΩ, 1 %, 1/16 W	MCR01MZPF1003	Chip Resistor	ROHM
C _{SS}	-	-	-	-	-
C ₁	1005	100 pF, CH, 50 V	GCM1552C1H101JA01	Ceramic Capacitor	Murata

Characteristic Data (Application Examples 4)

$V_{IN} = V_{EN}$, $T_a = 25\text{ }^\circ\text{C}$

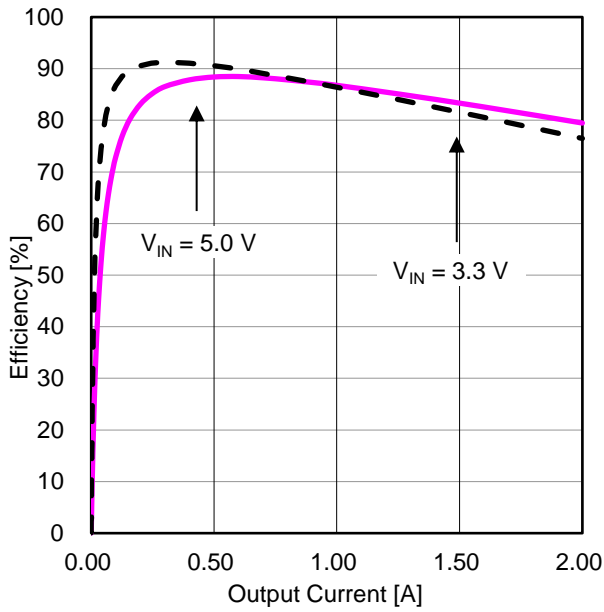

Figure 46. Efficiency vs Output Current

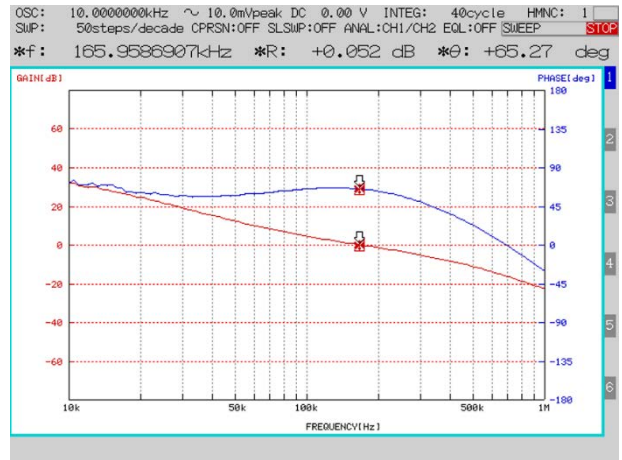

Figure 47. Frequency Characteristics ($I_{OUT} = 0.5\text{ A}$)

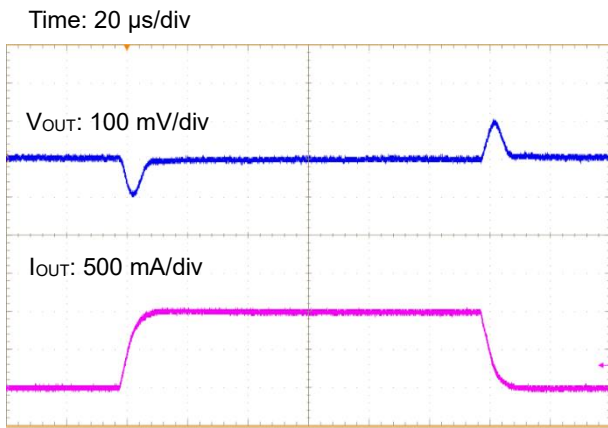

Figure 48. Load Transient Response ($I_{OUT} = 0\text{ A} \leftrightarrow 1\text{ A}$)

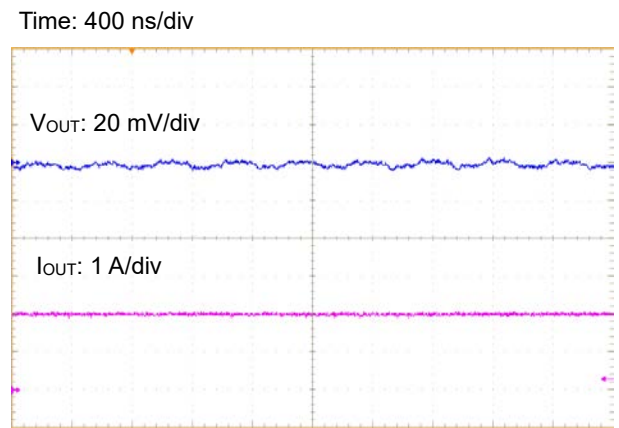

Figure 49. Output Ripple Voltage ($I_{OUT} = 2\text{ A}$)

Application Example 5

Table 11. Specification Example 5

Parameter	Symbol	Example Value
Product Name	IC	BD9S209NUX-C
Input Voltage	V_{IN}	5.0 V
Output Voltage	V_{OUT}	3.3 V
Soft Start Time	t_{SS}	1.0 ms (Typ)
Maximum Output Current	I_{OUTMAX}	2.0 A
Operation Temperature Range	T_a	-40 °C to +125 °C

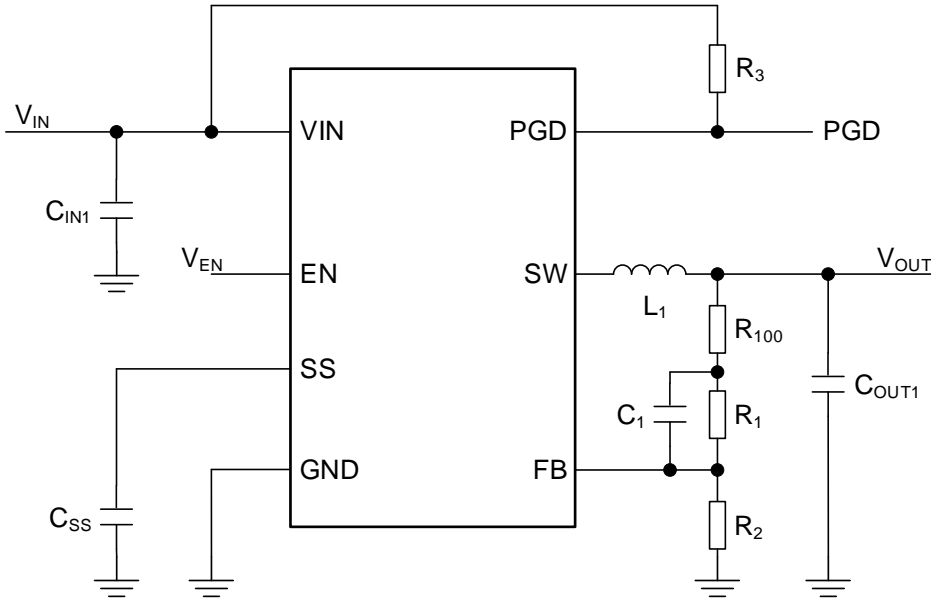

Figure 50. Measurement Circuit 5

Table 12. Parts List 5

No	Package	Parameters	Part Name (Series)	Type	Manufacturer
L ₁	2520	1.0 μH	TFM252012ALMA1R0M	Inductor	TDK
C _{OUT1}	2012	10 μF, X7R, 10 V	GCM21BR71A106KE21	Ceramic Capacitor	Murata
C _{IN1}	2012	10 μF, X7R, 10 V	GCM21BR71A106KE21	Ceramic Capacitor	Murata
R ₁₀₀	-	SHORT	-	-	-
R ₁	1005	75 kΩ, 1 %, 1/16 W	MCR01MZPF7502	Chip Resistor	ROHM
R ₂	1005	24 kΩ, 1 %, 1/16 W	MCR01MZPF2402	Chip Resistor	ROHM
R ₃	1005	100 kΩ, 1 %, 1/16 W	MCR01MZPF1003	Chip Resistor	ROHM
C _{SS}	-	-	-	-	-
C ₁	1005	100 pF, CH, 50 V	GCM1552C1H101JA01	Ceramic Capacitor	Murata

Characteristic Data (Application Examples 5)

$V_{IN} = V_{EN}$, $T_a = 25\text{ }^\circ\text{C}$

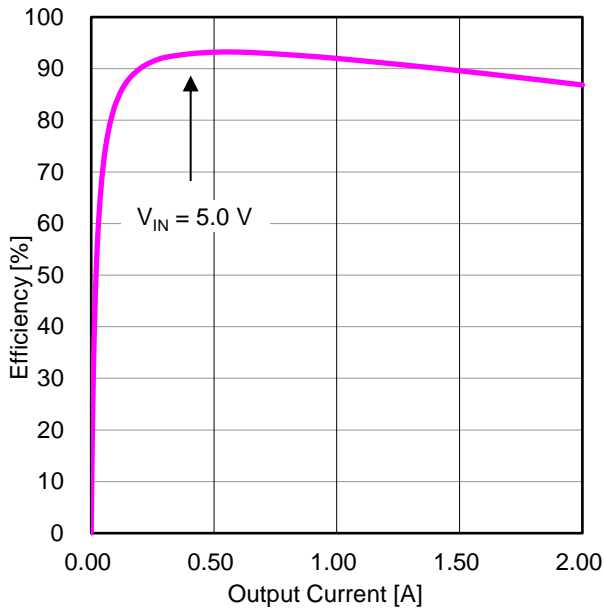

Figure 51. Efficiency vs Output Current

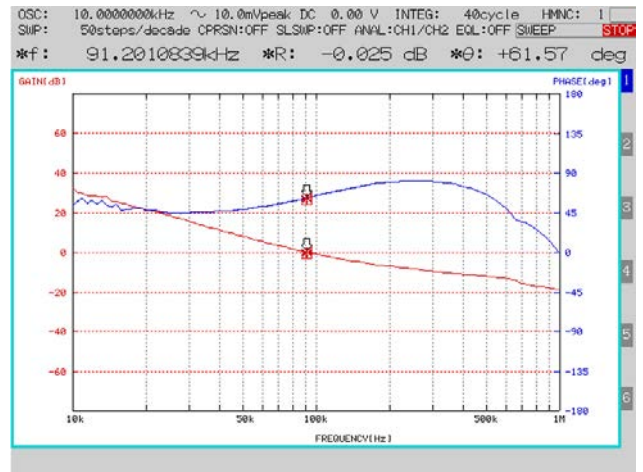

Figure 52. Frequency Characteristics ($I_{OUT} = 0.5\text{ A}$)

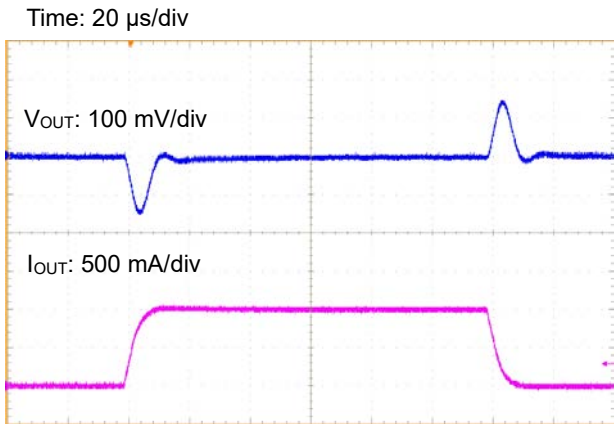

Figure 53. Load Transient Response ($I_{OUT} = 0\text{ A} \leftrightarrow 1\text{ A}$)

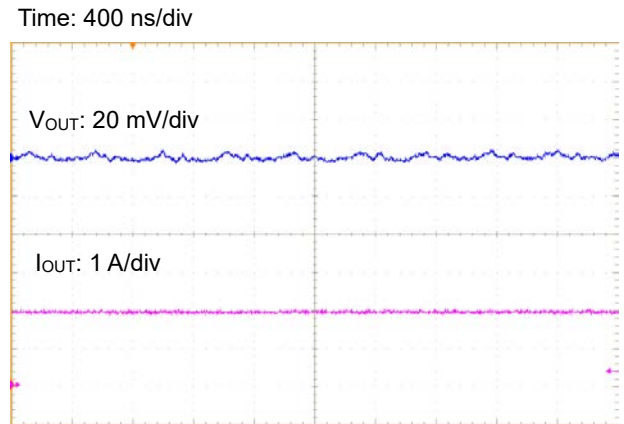

Figure 54. Output Ripple Voltage ($I_{OUT} = 2\text{ A}$)

PCB Layout Design

PCB layout design for DC/DC converter is very important. Appropriate layout can avoid various problems concerning power supply circuit. Figure 55 to 57 show the current path in a buck DC/DC converter circuit. The Loop 1 in Figure 55 is a current path when High Side Switch is ON and Low Side Switch is OFF, the Loop 2 in Figure 56 is when High Side Switch is OFF and Low Side Switch is ON. The thick line in Figure 57 shows the difference between Loop1 and Loop2. The current in thick line change sharply each time the switching element High Side and Low Side FET change from OFF to ON, and vice versa. These sharp changes induce a waveform with harmonics in this loop. Therefore, the loop area of thick line that is consisted by input capacitor and IC should be as small as possible to minimize noise. For more details, refer to application note of switching regulator series "PCB Layout Techniques of Buck Converter".

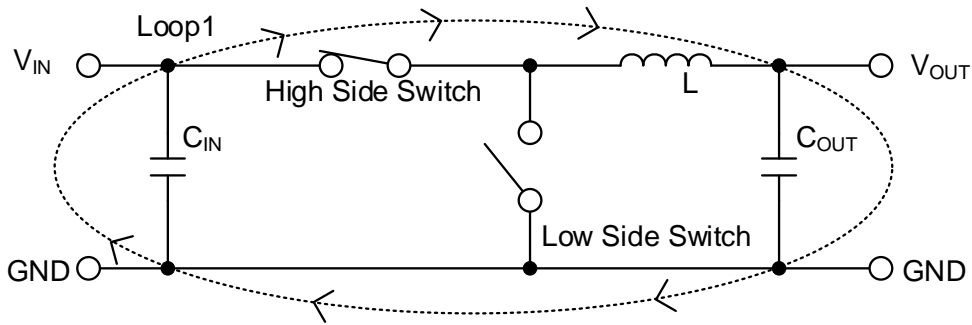

Figure 55. Current Path when High Side Switch = ON, Low Side Switch = OFF

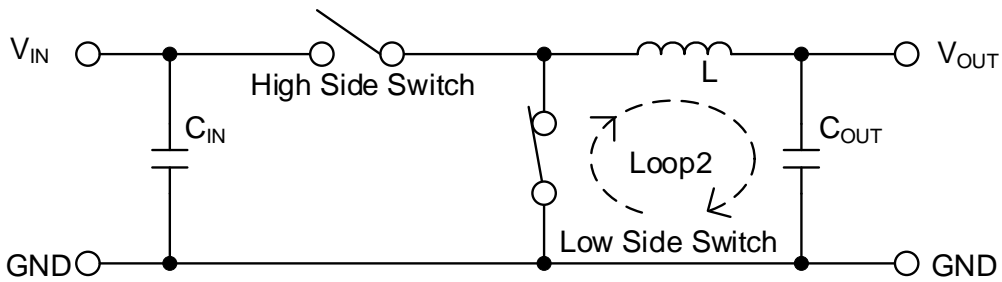

Figure 56. Current Path when High Side Switch = OFF, Low Side Switch = ON

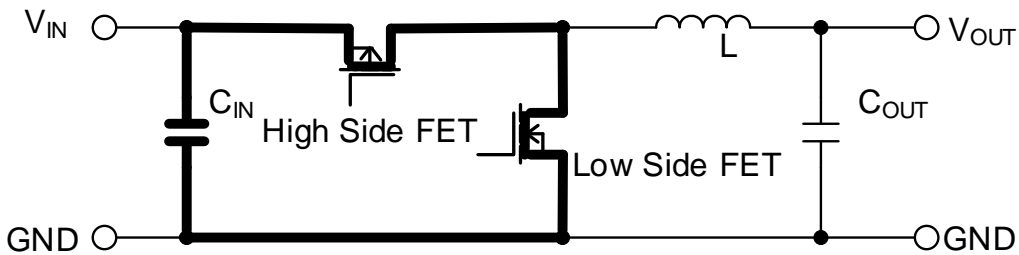
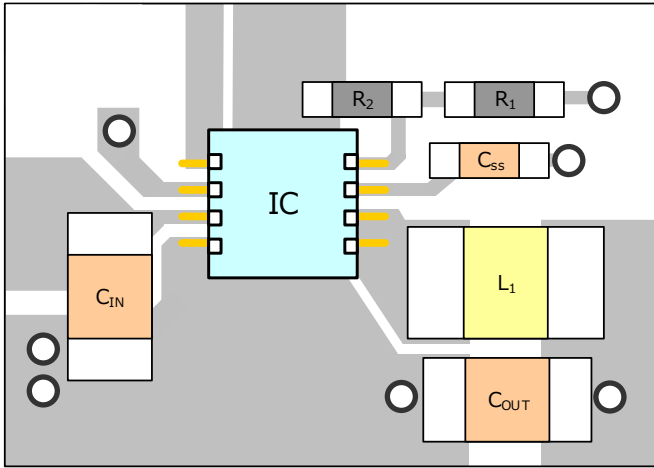

Figure 57. Difference of Current and Critical Area in Layout

PCB Layout Design – continued

When designing the PCB layout, Pay extra attention to the following points.

- Connect the input capacitor C_{IN} as close as possible to the VIN pin on the same plane as the IC.
- Switching nodes such as SW are susceptible to noise due to AC coupling with other nodes. Route the inductor pattern as thick and as short as possible.
- R_1 and R_2 shall be located as close as possible to the FB pin and the wiring between R_1 and R_2 to the FB pin shall be as short as possible.
- Provide line connected to FB far from the SW nodes.
- R_{100} is provided for the measurement of feedback frequency characteristics (optional). By inserting a resistor into R_{100} , it is possible to measure the frequency characteristics of feedback (phase margin) using FRA etc. R_{100} is short-circuited for normal use.



Example of Evaluation Board Layout (Top View)

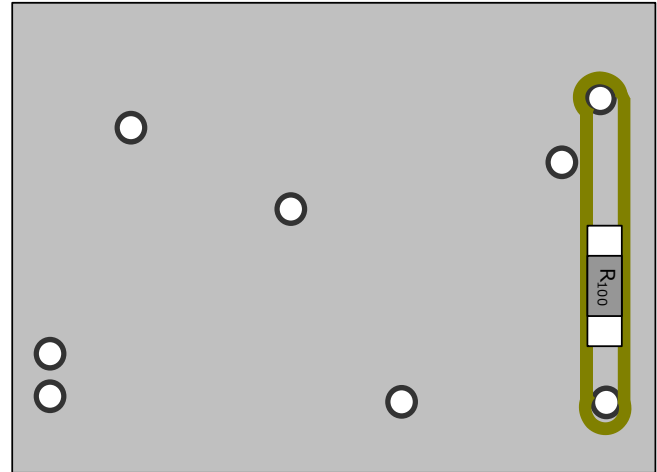

Example of Evaluation Board Layout (Bottom View)

Figure 58. Example of Evaluation Board Layout

Power Dissipation

For thermal design, be sure to operate the IC within the following conditions.
(Since the temperatures described hereunder are all guaranteed temperatures, take margin into account.)

1. The ambient temperature T_a is to be 125 °C or less.
2. The chip junction temperature T_j is to be 150 °C or less.

The chip junction temperature T_j can be considered in the following two patterns:

1. To obtain T_j from the package surface center temperature T_t in actual use

$$T_j = T_t + \psi_{JT} \times W \text{ [}^\circ\text{C]}$$

2. To obtain T_j from the ambient temperature T_a

$$T_j = T_a + \theta_{JA} \times W \text{ [}^\circ\text{C]}$$

where:

ψ_{JT} is junction to top characterization parameter ([Thermal Resistance](#)).

θ_{JA} is junction to ambient ([Thermal Resistance](#)).

The heat loss W of the IC can be obtained by the formula shown below:

$$W = R_{ONH} \times I_{OUT}^2 \times \frac{V_{OUT}}{V_{IN}} + R_{ONL} \times I_{OUT}^2 \left(1 - \frac{V_{OUT}}{V_{IN}}\right) + V_{IN} \times I_{CC} + \frac{1}{2} \times (tr + tf) \times V_{IN} \times I_{OUT} \times f_{SW} \text{ [W]}$$

where:

R_{ONH} is the High Side FET ON Resistance ([Electrical Characteristics](#)) [Ω].

R_{ONL} is the Low Side FET ON Resistance ([Electrical Characteristics](#)) [Ω].

I_{OUT} is the Output Current [A].

V_{OUT} is the Output Voltage [V].

V_{IN} is the Input Voltage [V].

I_{CC} is the Circuit Current ([Electrical Characteristics](#)) [A].

tr is the Switching Rise Time [s] (Typ:3 ns).

tf is the Switching Fall Time [s] (Typ:3 ns).

f_{SW} is the Switching Frequency ([Electrical Characteristics](#)) [Hz].

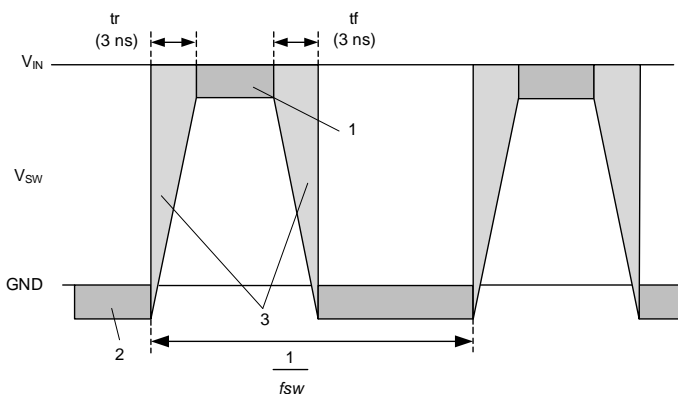

$$1. R_{ONH} \times I_{OUT}^2$$

$$2. R_{ONL} \times I_{OUT}^2$$

$$3. \frac{1}{2} \times (tr + tf) \times V_{IN} \times I_{OUT} \times f_{SW}$$

Figure 59. SW Waveform

I/O Equivalence Circuits *(Note 1)*

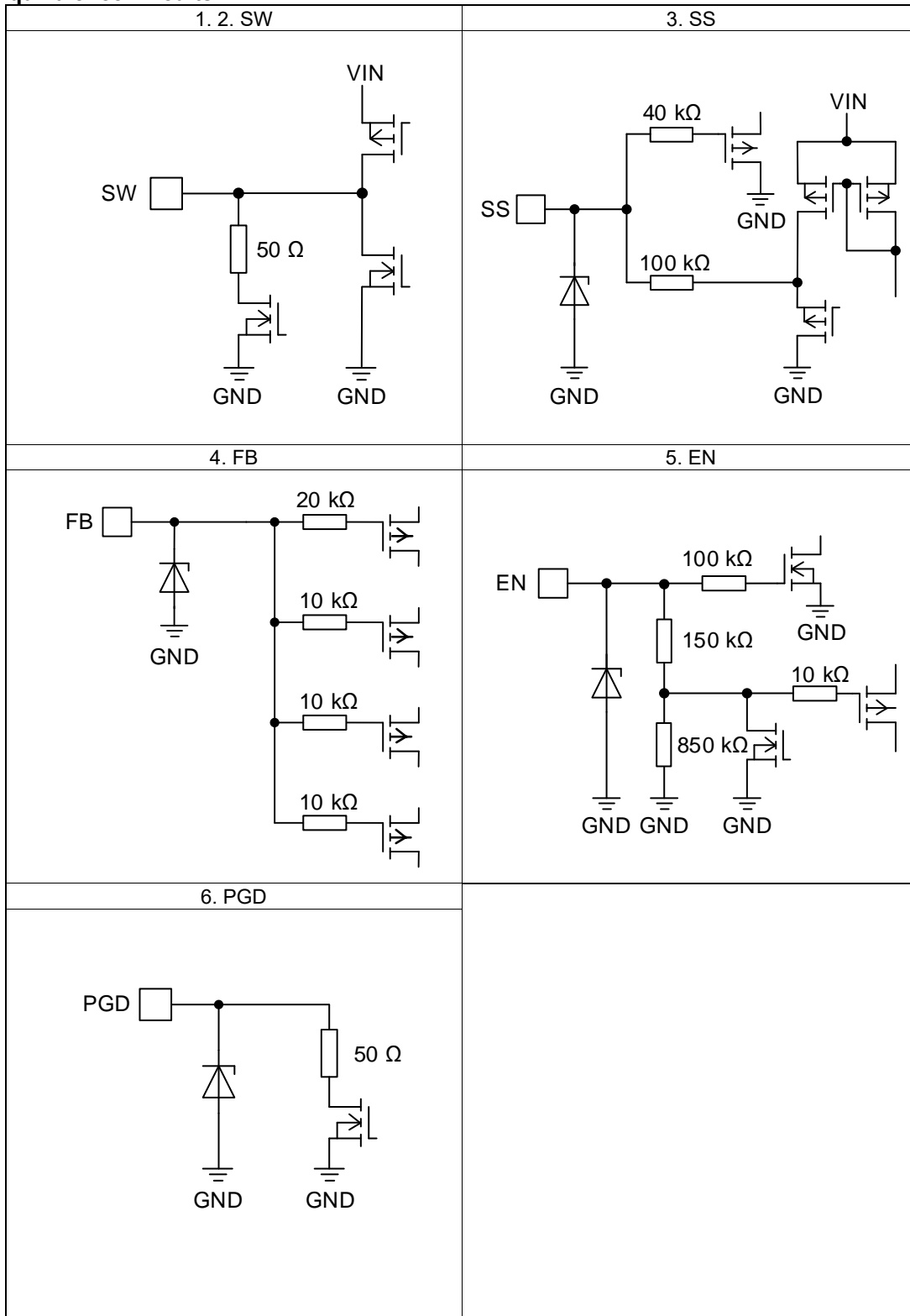

(Note 1) Resistance value is Typical.

Operational Notes

1. Reverse Connection of Power Supply

Connecting the power supply in reverse polarity can damage the IC. Take precautions against reverse polarity when connecting the power supply, such as mounting an external diode between the power supply and the IC's power supply pins.

2. Power Supply Lines

Design the PCB layout pattern to provide low impedance supply lines. Furthermore, connect a capacitor to ground at all power supply pins. Consider the effect of temperature and aging on the capacitance value when using electrolytic capacitors.

3. Ground Voltage

Ensure that no pins are at a voltage below that of the ground pin at any time, even during transient condition. However, pins that drive inductive loads (e.g. motor driver outputs, DC-DC converter outputs) may inevitably go below ground due to back EMF or electromotive force. In such cases, the user should make sure that such voltages going below ground will not cause the IC and the system to malfunction by examining carefully all relevant factors and conditions such as motor characteristics, supply voltage, operating frequency and PCB wiring to name a few.

4. Ground Wiring Pattern

When using both small-signal and large-current ground traces, the two ground traces should be routed separately but connected to a single ground at the reference point of the application board to avoid fluctuations in the small-signal ground caused by large currents. Also ensure that the ground traces of external components do not cause variations on the ground voltage. The ground lines must be as short and thick as possible to reduce line impedance.

5. Recommended Operating Conditions

The function and operation of the IC are guaranteed within the range specified by the recommended operating conditions. The characteristic values are guaranteed only under the conditions of each item specified by the electrical characteristics.

6. Inrush Current

When power is first supplied to the IC, it is possible that the internal logic may be unstable and inrush current may flow instantaneously due to the internal powering sequence and delays, especially if the IC has more than one power supply. Therefore, give special consideration to power coupling capacitance, power wiring, width of ground wiring, and routing of connections.

7. Testing on Application Boards

When testing the IC on an application board, connecting a capacitor directly to a low-impedance output pin may subject the IC to stress. Always discharge capacitors completely after each process or step. The IC's power supply should always be turned off completely before connecting or removing it from the test setup during the inspection process. To prevent damage from static discharge, ground the IC during assembly and use similar precautions during transport and storage.

8. Inter-pin Short and Mounting Errors

Ensure that the direction and position are correct when mounting the IC on the PCB. Incorrect mounting may result in damaging the IC. Avoid nearby pins being shorted to each other especially to ground, power supply and output pin. Inter-pin shorts could be due to many reasons such as metal particles, water droplets (in very humid environment) and unintentional solder bridge deposited in between pins during assembly to name a few.

9. Unused Input Pins

Input pins of an IC are often connected to the gate of a MOS transistor. The gate has extremely high impedance and extremely low capacitance. If left unconnected, the electric field from the outside can easily charge it. The small charge acquired in this way is enough to produce a significant effect on the conduction through the transistor and cause unexpected operation of the IC. So unless otherwise specified, unused input pins should be connected to the power supply or ground line.

Operational Notes – continued

10. Regarding the Input Pin of the IC

This monolithic IC contains P+ isolation and P substrate layers between adjacent elements in order to keep them isolated. P-N junctions are formed at the intersection of the P layers with the N layers of other elements, creating a parasitic diode or transistor. For example (refer to figure below):

When $GND > Pin A$ and $GND > Pin B$, the P-N junction operates as a parasitic diode.

When $GND > Pin B$, the P-N junction operates as a parasitic transistor.

Parasitic diodes inevitably occur in the structure of the IC. The operation of parasitic diodes can result in mutual interference among circuits, operational faults, or physical damage. Therefore, conditions that cause these diodes to operate, such as applying a voltage lower than the GND voltage to an input pin (and thus to the P substrate) should be avoided.

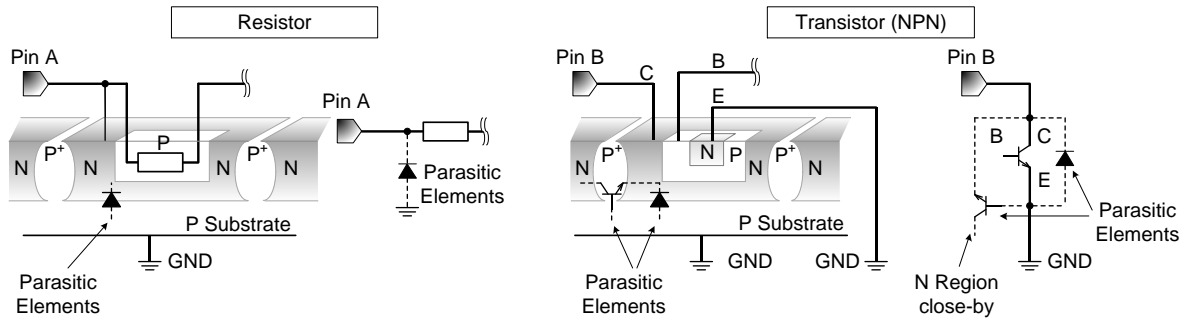

Figure 60. Example of Monolithic IC Structure

11. Ceramic Capacitor

When using a ceramic capacitor, determine a capacitance value considering the change of capacitance with temperature and the decrease in nominal capacitance due to DC bias and others.

12. Thermal Shutdown Circuit (TSD)

This IC has a built-in thermal shutdown circuit that prevents heat damage to the IC. Normal operation should always be within the IC's maximum junction temperature rating. If however the rating is exceeded for a continued period, the junction temperature (T_j) will rise which will activate the TSD circuit that will turn OFF power output pins. When the T_j falls below the TSD threshold, the circuits are automatically restored to normal operation.

Note that the TSD circuit operates in a situation that exceeds the absolute maximum ratings and therefore, under no circumstances, should the TSD circuit be used in a set design or for any purpose other than protecting the IC from heat damage.

13. Over Current Protection Circuit (OCP)

This IC incorporates an integrated overcurrent protection circuit that is activated when the load is shorted. This protection circuit is effective in preventing damage due to sudden and unexpected incidents. However, the IC should not be used in applications characterized by continuous operation or transitioning of the protection circuit.

Ordering Information

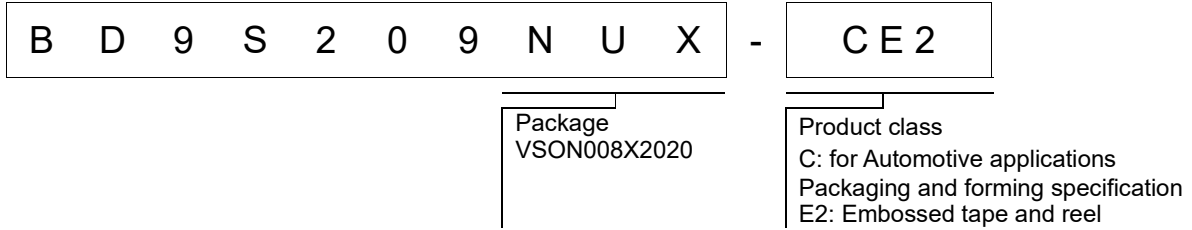

Marking Diagram

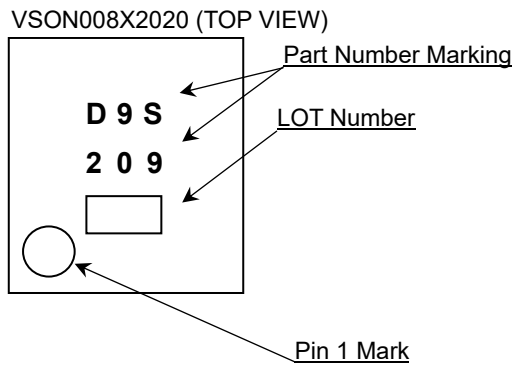

Physical Dimension and Packing Information

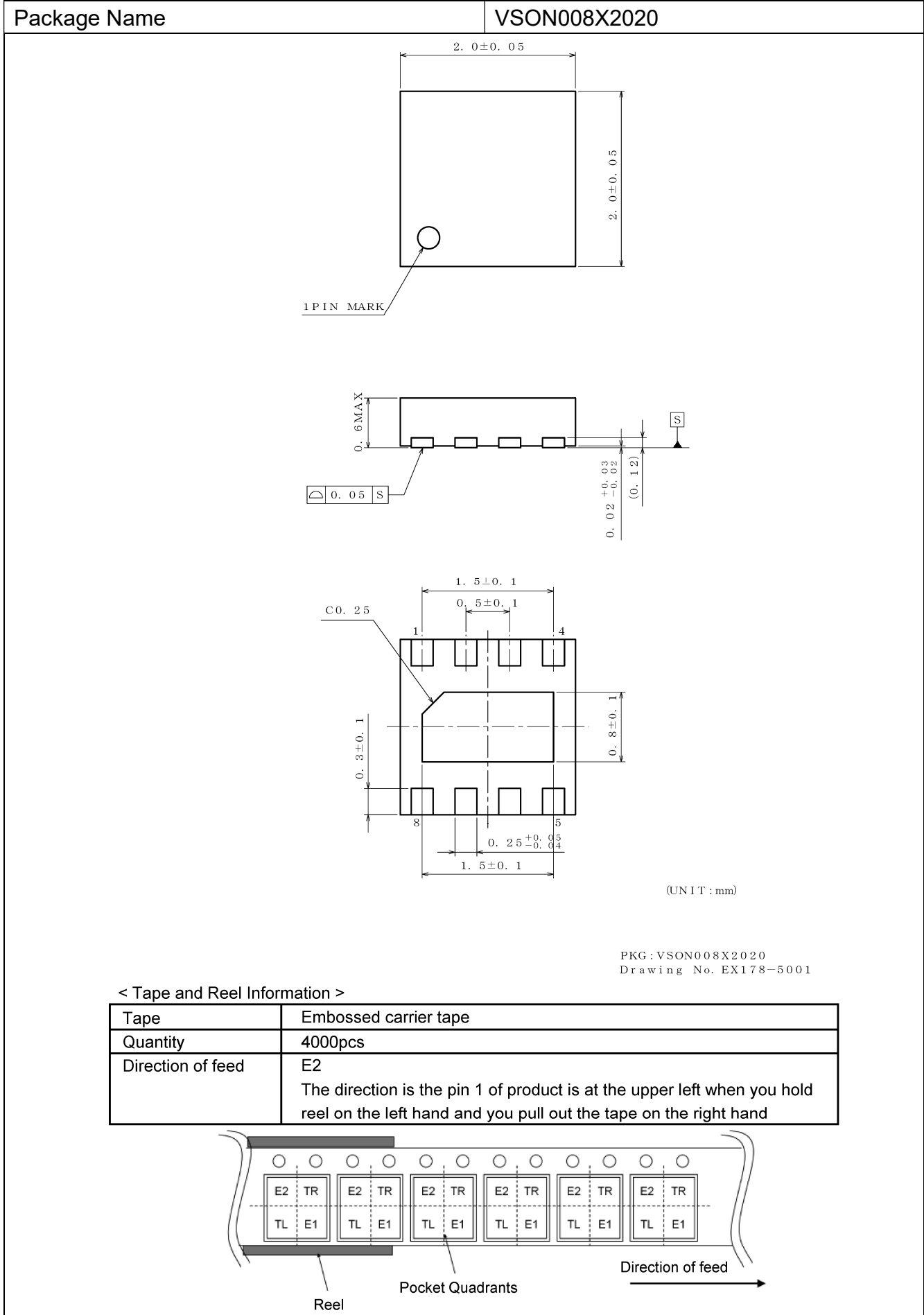

Revision History

Date	Revision	Changes
06.Apr.2022	001	New Release

Notice

Precaution on using ROHM Products

1. If you intend to use our Products in devices requiring extremely high reliability (such as medical equipment ^(Note 1), aircraft/spacecraft, nuclear power controllers, etc.) and whose malfunction or failure may cause loss of human life, bodily injury or serious damage to property ("Specific Applications"), please consult with the ROHM sales representative in advance. Unless otherwise agreed in writing by ROHM in advance, ROHM shall not be in any way responsible or liable for any damages, expenses or losses incurred by you or third parties arising from the use of any ROHM's Products for Specific Applications.

(Note1) Medical Equipment Classification of the Specific Applications

JAPAN	USA	EU	CHINA
CLASS III	CLASS III	CLASS II b	CLASS III
CLASS IV		CLASS III	

2. ROHM designs and manufactures its Products subject to strict quality control system. However, semiconductor products can fail or malfunction at a certain rate. Please be sure to implement, at your own responsibilities, adequate safety measures including but not limited to fail-safe design against the physical injury, damage to any property, which a failure or malfunction of our Products may cause. The following are examples of safety measures:
 - [a] Installation of protection circuits or other protective devices to improve system safety
 - [b] Installation of redundant circuits to reduce the impact of single or multiple circuit failure
3. Our Products are not designed under any special or extraordinary environments or conditions, as exemplified below. Accordingly, ROHM shall not be in any way responsible or liable for any damages, expenses or losses arising from the use of any ROHM's Products under any special or extraordinary environments or conditions. If you intend to use our Products under any special or extraordinary environments or conditions (as exemplified below), your independent verification and confirmation of product performance, reliability, etc, prior to use, must be necessary:
 - [a] Use of our Products in any types of liquid, including water, oils, chemicals, and organic solvents
 - [b] Use of our Products outdoors or in places where the Products are exposed to direct sunlight or dust
 - [c] Use of our Products in places where the Products are exposed to sea wind or corrosive gases, including Cl₂, H₂S, NH₃, SO₂, and NO₂
 - [d] Use of our Products in places where the Products are exposed to static electricity or electromagnetic waves
 - [e] Use of our Products in proximity to heat-producing components, plastic cords, or other flammable items
 - [f] Sealing or coating our Products with resin or other coating materials
 - [g] Use of our Products without cleaning residue of flux (Exclude cases where no-clean type fluxes is used. However, recommend sufficiently about the residue.); or Washing our Products by using water or water-soluble cleaning agents for cleaning residue after soldering
 - [h] Use of the Products in places subject to dew condensation
4. The Products are not subject to radiation-proof design.
5. Please verify and confirm characteristics of the final or mounted products in using the Products.
6. In particular, if a transient load (a large amount of load applied in a short period of time, such as pulse, is applied, confirmation of performance characteristics after on-board mounting is strongly recommended. Avoid applying power exceeding normal rated power; exceeding the power rating under steady-state loading condition may negatively affect product performance and reliability.
7. De-rate Power Dissipation depending on ambient temperature. When used in sealed area, confirm that it is the use in the range that does not exceed the maximum junction temperature.
8. Confirm that operation temperature is within the specified range described in the product specification.
9. ROHM shall not be in any way responsible or liable for failure induced under deviant condition from what is defined in this document.

Precaution for Mounting / Circuit board design

1. When a highly active halogenous (chlorine, bromine, etc.) flux is used, the residue of flux may negatively affect product performance and reliability.
2. In principle, the reflow soldering method must be used on a surface-mount products, the flow soldering method must be used on a through hole mount products. If the flow soldering method is preferred on a surface-mount products, please consult with the ROHM representative in advance.

For details, please refer to ROHM Mounting specification

Precautions Regarding Application Examples and External Circuits

1. If change is made to the constant of an external circuit, please allow a sufficient margin considering variations of the characteristics of the Products and external components, including transient characteristics, as well as static characteristics.
2. You agree that application notes, reference designs, and associated data and information contained in this document are presented only as guidance for Products use. Therefore, in case you use such information, you are solely responsible for it and you must exercise your own independent verification and judgment in the use of such information contained in this document. ROHM shall not be in any way responsible or liable for any damages, expenses or losses incurred by you or third parties arising from the use of such information.

Precaution for Electrostatic

This Product is electrostatic sensitive product, which may be damaged due to electrostatic discharge. Please take proper caution in your manufacturing process and storage so that voltage exceeding the Products maximum rating will not be applied to Products. Please take special care under dry condition (e.g. Grounding of human body / equipment / solder iron, isolation from charged objects, setting of Ionizer, friction prevention and temperature / humidity control).

Precaution for Storage / Transportation

1. Product performance and soldered connections may deteriorate if the Products are stored in the places where:
 - [a] the Products are exposed to sea winds or corrosive gases, including Cl₂, H₂S, NH₃, SO₂, and NO₂
 - [b] the temperature or humidity exceeds those recommended by ROHM
 - [c] the Products are exposed to direct sunshine or condensation
 - [d] the Products are exposed to high Electrostatic
2. Even under ROHM recommended storage condition, solderability of products out of recommended storage time period may be degraded. It is strongly recommended to confirm solderability before using Products of which storage time is exceeding the recommended storage time period.
3. Store / transport cartons in the correct direction, which is indicated on a carton with a symbol. Otherwise bent leads may occur due to excessive stress applied when dropping of a carton.
4. Use Products within the specified time after opening a humidity barrier bag. Baking is required before using Products of which storage time is exceeding the recommended storage time period.

Precaution for Product Label

A two-dimensional barcode printed on ROHM Products label is for ROHM's internal use only.

Precaution for Disposition

When disposing Products please dispose them properly using an authorized industry waste company.

Precaution for Foreign Exchange and Foreign Trade act

Since concerned goods might be fallen under listed items of export control prescribed by Foreign exchange and Foreign trade act, please consult with ROHM in case of export.

Precaution Regarding Intellectual Property Rights

1. All information and data including but not limited to application example contained in this document is for reference only. ROHM does not warrant that foregoing information or data will not infringe any intellectual property rights or any other rights of any third party regarding such information or data.
2. ROHM shall not have any obligations where the claims, actions or demands arising from the combination of the Products with other articles such as components, circuits, systems or external equipment (including software).
3. No license, expressly or implied, is granted hereby under any intellectual property rights or other rights of ROHM or any third parties with respect to the Products or the information contained in this document. Provided, however, that ROHM will not assert its intellectual property rights or other rights against you or your customers to the extent necessary to manufacture or sell products containing the Products, subject to the terms and conditions herein.

Other Precaution

1. This document may not be reprinted or reproduced, in whole or in part, without prior written consent of ROHM.
2. The Products may not be disassembled, converted, modified, reproduced or otherwise changed without prior written consent of ROHM.
3. In no event shall you use in any way whatsoever the Products and the related technical information contained in the Products or this document for any military purposes, including but not limited to, the development of mass-destruction weapons.
4. The proper names of companies or products described in this document are trademarks or registered trademarks of ROHM, its affiliated companies or third parties.

General Precaution

1. Before you use our Products, you are requested to carefully read this document and fully understand its contents. ROHM shall not be in any way responsible or liable for failure, malfunction or accident arising from the use of any ROHM's Products against warning, caution or note contained in this document.
2. All information contained in this document is current as of the issuing date and subject to change without any prior notice. Before purchasing or using ROHM's Products, please confirm the latest information with a ROHM sales representative.
3. The information contained in this document is provided on an "as is" basis and ROHM does not warrant that all information contained in this document is accurate and/or error-free. ROHM shall not be in any way responsible or liable for any damages, expenses or losses incurred by you or third parties resulting from inaccuracy or errors of or concerning such information.