

PRODUCT NUMBER

SEE P/N SCHEME

(0.64 TYP)

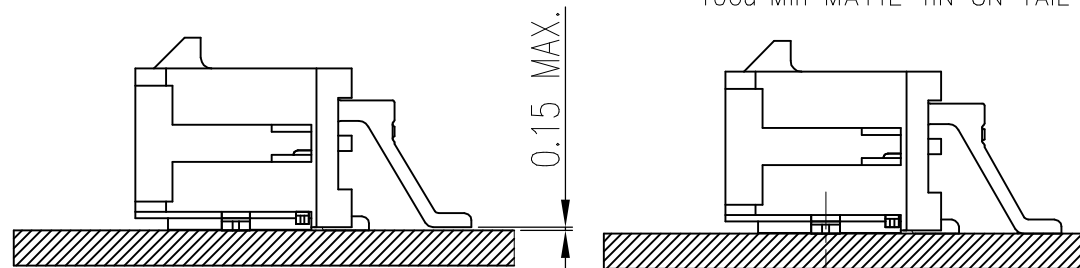
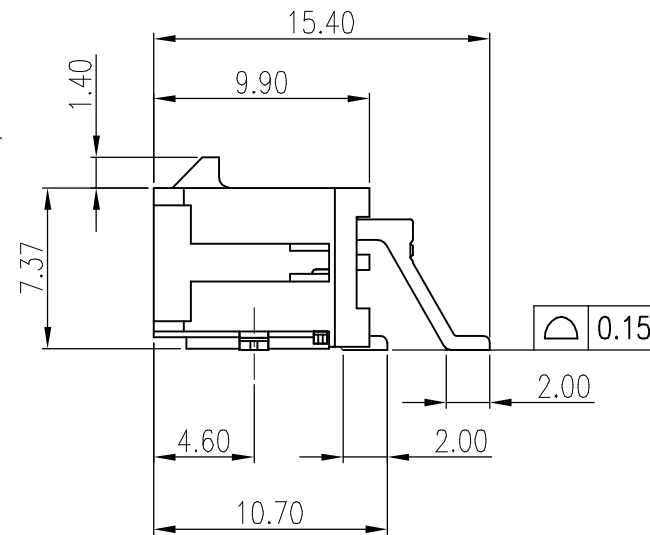
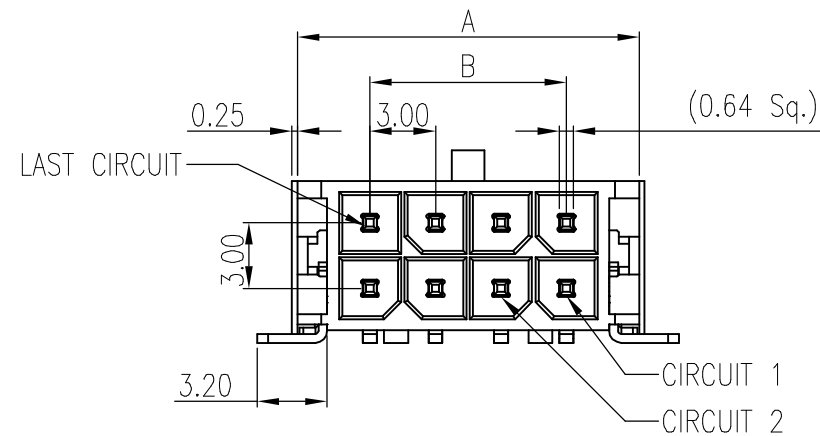
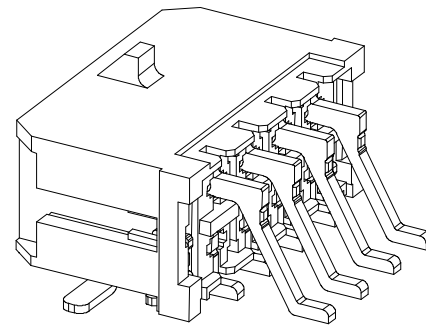
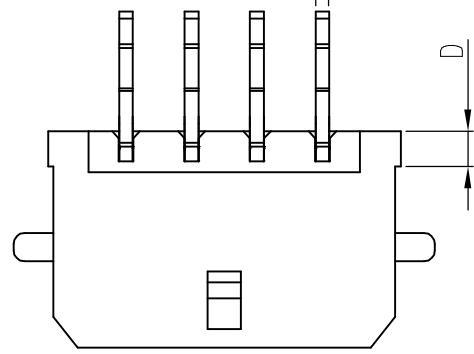

COPLANARITY DETAIL
(SEE NOTE #8)

LOCATION DETAIL
(SEE NOTE #9)

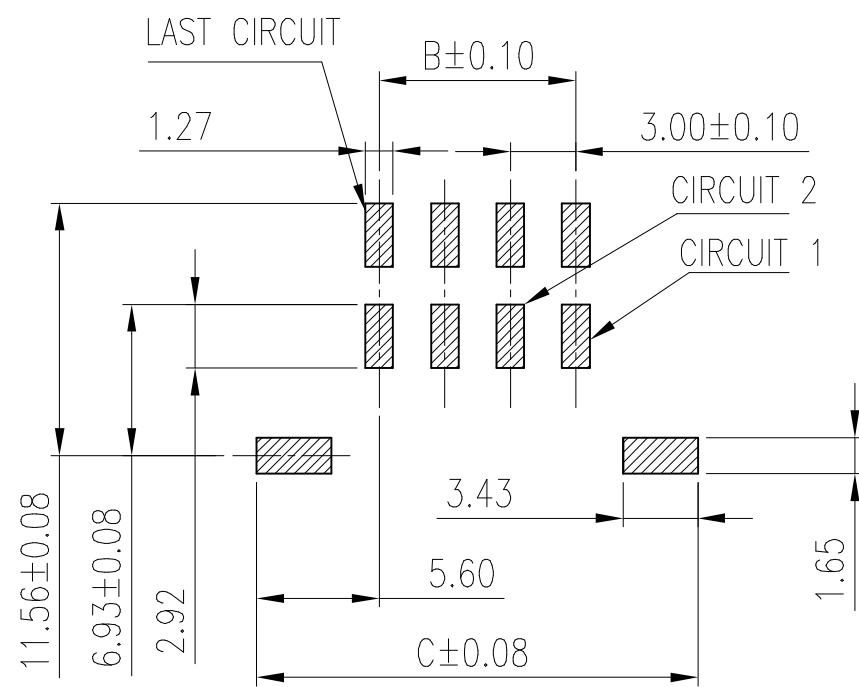

RECOMMENDED PCB LAYOUT
GENERAL TOLERANCE: ±0.05

NOTE:

- MATERIAL:
HOUSING: LCP, UL94V-0, HALOGEN FREE, COLOR: BLACK
CONTACT: COPPER ALLOY.
HOLD DOWN: COPPER ALLOY
- CONTACT FINISH: NICKEL 50u" Min. UNDERPLATED OVERALL.
OPTIONAL PLATING ON CONTACT AREA, 100u" MIN MATTE TIN ON SOLDER TAIL.
HOLD DOWN: 100u" MIN MATTE TIN OVER 50u" Min. NICKEL
- REFER GS-20-0399 APPLICATION SPECIFICATION FOR MATING CONNECTOR.
- PRODUCT SPECIFICATION: GS-12-1177.
- TAPE & REEL PACKAGE SPECIFICATION: GS-14-2359.
- APPLICATION SPECIFICATION: GS-20-0399
- THE HOUSING WILL WITHSTAND EXPOSURE TO 260°C PEAK TEMPERATURE FOR 10 SECONDS IN A REFLOW OVEN.
- THE COPLANARITY DIMENSION IS ESTABLISHED BY PLACING THE ASSEMBLY ON A FLAT SURFACE. THE DISTANCE FROM THAT SURFACE TO THE BOTTOM OF ANY TERMINAL OR NAIL MUST NOT EXCEED 0.15mm.
- TO AVOID INTERFERENCE BETWEEN RECEPTACLE AND PCB, HEADER MUST BE PLACED WITHIN 10.16mm MAX. FROM EDGE OF PCB, AS SHOWN IN LOCATION DETAIL.
- LEAD FREE PRODUCTS MEET EUROPEAN UNION DIRECTIVES AND OTHER COUNTRY REGULATIONS AS DESCRIBED IN GS-47-0004
- PART NUMBER SCHEME:

10137924- XX X X X LF

POS. CODE:
02: 2 POS
04: 4 POS
24: 24 POS

LEAD FREE
PACKAGING OPTION:
BLANK: TAPE & REEL
Q: CUSTOMER SPECIAL TAPE & REEL
GLOW WIRE COMPATIBLE:
1: COMPATIBLE
2: NON-COMPATIBLE

- PLATING CODE:
- 100u" Min. MATTE TIN OVERALL
 - GOLD FLASH ON CONTACT AREA, 100u" Min MATTE TIN ON TAIL
 - 15u" Min Au ON CONTACT AREA, 100u" Min MATTE TIN ON TAIL
 - 30u" Min Au ON CONTACT AREA, 100u" Min MATTE TIN ON TAIL

P/N & DIMENSION TABLE

PART NO.	POS	A	B	C	D
10137924-02XXXLF	02	6.65	NA	11.20	6.74
10137924-04XXXLF	04	9.65	3.00	14.20	
10137924-06XXXLF	06	12.65	6.00	17.20	
10137924-08XXXLF	08	15.65	9.00	20.20	1.60
10137924-10XXXLF	10	18.65	12.00	23.20	
10137924-12XXXLF	12	21.65	15.00	26.20	
10137924-14XXXLF	14	24.65	18.00	29.20	
10137924-16XXXLF	16	27.65	21.00	32.20	
10137924-18XXXLF	18	30.65	24.00	35.20	
10137924-20XXXLF	20	33.65	27.00	38.20	1.60
10137924-22XXXLF	22	36.65	30.00	41.20	
10137924-24XXXLF	24	39.65	33.00	44.20	

mat'l. code		surface		tolerance		projection		product family	
		ISO 1302		ISO 406 ISO 1101		mm		MINITEK PWR3.0	
ltr ecn no dr date		tolerances unless otherwise specified		angles linear		scale N.T.S		title	
A		TAI	2015-11-30	.0±.30				MINITEK PWR 3.0 R/A HEADER, DUAL ROW SMT TAIL & HOLD DOWN	
B	ELX-N-24982	TAI	2016-09-21	.00±.20					
C	ELX-N-26477	TONY	2017-03-27	0°±2'					
D	ELX-N-29860	TONY	2018-04-16	dr	KENNY TAI	2015-11-26	dwg no sheet 1 of 2 size		
E	ELX-I-43460	AKHIL	2022-01-21	engr	AKHIL RAJAN	2022-01-21	10137924 A3		
				chr	MITHUN PAUL	2022-01-21	type Product Customer Drawing		
				appd	SPK	2022-01-21			
sheet index	revision sheet	E	E						
		1	2						



Amphenol
FCi

© 2016 AFci

1

2 3

4

5

6

A

B

C

D

A

B

C

D

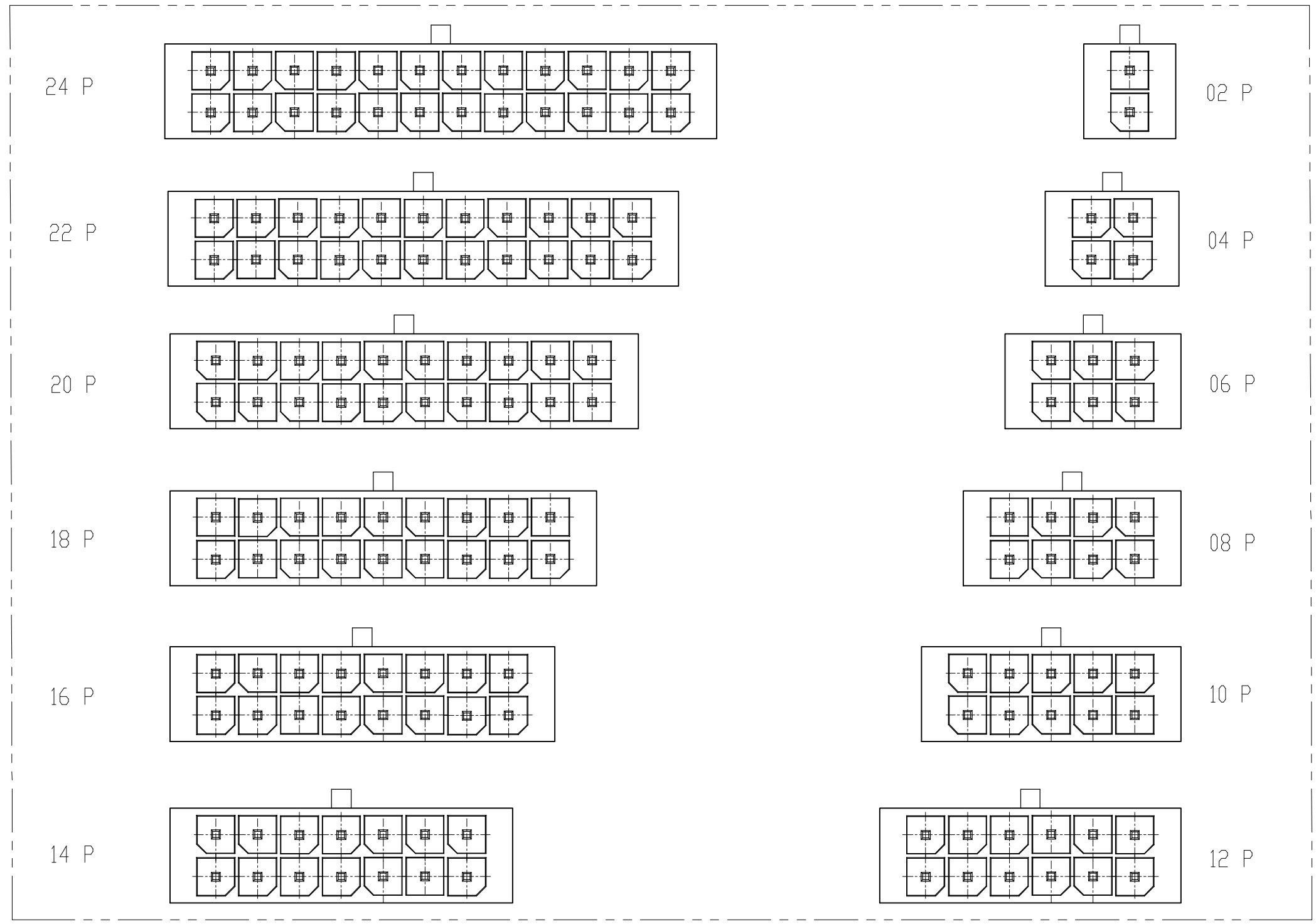
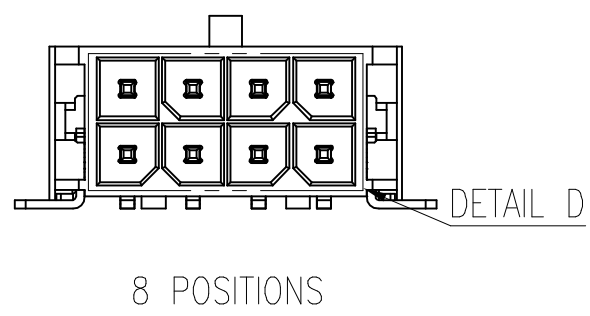

DETAIL D

mat'l. code		surface		tolerance		projection		product family	
		ISO 1302		ISO 406 ISO 1101				MINITEK PWR3.0	
ltr		ecn no		dr		date		title	
								MINITEK PWR 3.0 R/A HEADER, DUAL ROW SMT TAIL & HOLD DOWN	
		angles		linear		mm		dwg no	
		0°±2'				scale N.T.S		sheet 2 of 2	
		dr		KENNY TAI		2015-11-26		size	
		enr		AKHIL RAJAN		2022-01-21		10137924	
		chr		MITHUN PAUL		2022-01-21		A3	
		app		SPK		2022-01-21		type	
		Product Customer Drawing							
sheet index		revision sheet		E 1		E 2			