

ClearClock™ Oscillator Family | Low Jitter | 3.2x2.5mm XO

AX3

Request Samples



Check Inventory



ESD Sensitive



3.2 x 2.5 x 1.0 mm

RoHS/RoHS II Compliant

MSL Level = 1

Features

- Exceptionally Low RMS Jitter: < 80fs Typ (150fs Max @ 156.25MHz)
- Available in industry standard frequencies between 100MHz and 212.5MHz
- Lowest power consumption in its class(16mA Typ LVDS @ 156.25MHz)
- ±25ppm stability over industrial operating temperature (-40 to +85°C)
- 3.3V, 2.5V, 1.8V supply voltage options
- LVPECL, LVDS, HCSL differential outputs
- Industry standard 3.2 x 2.5 x 1.0 mm footprint
- Available in Abracon's Global Distribution Network

Applications

- PCI Express
- 10G/40G/100G optical Ethernet
- Networking & communication
- RF systems, base stations (BTS)
- Data center
- Test & measurement

Key Electrical Specifications

Parameters		Min.	Typ.	Max.	Unit	Notes
Frequency Range		100		212.500	MHz	
Standard Available Frequencies		100, 114.285, 122.88, 125, 148.5, 150, 155.52, 156.25, 200, 212.500			MHz	Contact Abracon for availability of frequencies not listed
Supply Voltage (Vdd) ^[Note 1]		2.97	3.3	3.63	V	Option "A"
		2.37	2.5	2.62		Option "B"
		1.71	1.8	1.89		Option "C"
Supply Current (Idd)	LVPECL		30	50	mA	@ 200MHz; @ Vdd=3.3V
	LVDS		16	27		@ 200MHz; @ Vdd=3.3V
	HCSL		17	30		@ 200MHz; @ Vdd=3.3V
Operating Temperature Range		-20		70	°C	Option "D"
		-40		85		Option "F" or "Q"
Storage Temperature		-55		150	°C	
Frequency Accuracy (Initial Set-Tolerance) ^[Note 2] at time of shipment (Pre-Reflow) @ +25°C		-10	< ±5	10	ppm	Relative to carrier frequency
Frequency Stability over ^[Note 3] Operating Temperature Range		-15		15	ppm	Option "D" (-20°C to +70°C)
		-20		20		Option "Q" (-40°C to +85°C)
		-25		25		Option "F" (-40°C to +85°C)
Aging over 20 Year Product Life ^[Note 4]		-15		15	ppm	



5101 Hidden Creek Ln Spicewood TX 78669
 Phone: 512-371-6159 | Fax: 512-351-8858
 For terms and conditions of sales, please visit:
www.abracon.com

REVISED: 02-25-22

ABRACON IS
 ISO9001-2015
 CERTIFIED

ClearClock™ Oscillator Family | Low Jitter | 3.2x2.5mm XO

AX3

Request Samples



Check Inventory



ESD Sensitive



3.2 x 2.5 x 1.0 mm
RoHS/RoHS II Compliant
MSL Level = 1

Parameters		Min.	Typ.	Max.	Unit	Notes
All-Inclusive Frequency Accuracy (Total Stability) over 20 Year Product Life [Notes 4,5]		-40		40	ppm	Option "D" (-20°C to +70°C)
		-45		45		Option "Q" (-40°C to +85°C)
		-50		50		Option "F" (-40°C to +85°C)
Rise (Tr) / Fall (Tf) Time 20% to 80% of Waveform	LVPECL		0.2	0.4	ns	@ Vdd=3.3V, RL=50Ω
			0.3	0.6		@ Vdd=2.5V, RL=50Ω
	LVDS		0.15	0.4		@ Vdd=3.3V, RL=100Ω
			0.15	0.4		@ Vdd=2.5V, RL=100Ω
			0.3	0.5		@ Vdd=1.8V, RL=100Ω
	HCSL		0.3	0.5		@ Vdd=3.3V, RL=50Ω to GND
			0.3	0.5		@ Vdd=2.5V, RL=50Ω to GND
			0.3	0.6		@ Vdd=1.8V, RL=50Ω to GND
Duty Cycle		45		55	%	
Start-up Time [Note 2]			< 2	5	ms	

Note 1: Supply voltage (Vdd) = 1.8V option not available with LVPECL output

Note 2: Relative to initial measured frequency @ +25°C

Note 3: Option Q only available in select frequencies. Please contact Abracon for availability

Note 4: Relative to post-reflow frequency

Note 5: Includes temperature stability, initial frequency accuracy, load pulling, power supply variation, and 20-year aging



5101 Hidden Creek Ln Spicewood TX 78669
 Phone: 512-371-6159 | Fax: 512-351-8858
 For terms and conditions of sales, please visit:
www.abracon.com

REVISED: 02-25-22

ABRACON IS
 ISO9001-2015
 CERTIFIED

ClearClock™ Oscillator Family | Low Jitter | 3.2x2.5mm XO

AX3

Request Samples



Check Inventory



ESD Sensitive



3.2 x 2.5 x 1.0 mm
RoHS/RoHS II Compliant
 MSL Level = 1

Parameters		Min.	Typ.	Max.	Unit	Notes
Differential Output High Voltage (VOH) Output Low Voltage (VOL)	LVPECL	V _{OH}	V _{dd} -1.03		V _{dd} -0.88	V R _L =50Ω to V _{dd} -2.0V R _L =100Ω between both outputs R _L =50Ω to ground on each output
		V _{OL}	V _{dd} -1.85		V _{dd} -1.60	
	LVDS	V _{OH}		1.40	1.60	
		V _{OL}	0.90	1.10		
	HCSL	V _{OH}	0.40	0.74	0.85	
		V _{OL}	-0.15	0.00	0.15	
Output Voltage Swing			0.595	0.750	0.930	V LVPECL
			0.250	0.350	0.450	V LVDS
			0.620	0.700	0.780	V HCSL
Output Enable & Disable Control			0.7*(V _{dd})			V Output Enable or No Connect
					0.3*(V _{dd})	V Output Disable (High Impedance)
Output Enable Time			< 1	5.0	ms	
Output Disable Time				0.2	μs	
Output Disable Current Consumption				< 10	μA	OE ≤ 0.3V



5101 Hidden Creek Ln Spicewood TX 78669
 Phone: 512-371-6159 | Fax: 512-351-8858
 For terms and conditions of sales, please visit:
www.abracon.com

REVISED: 02-25-22

ABRACON IS
 ISO9001-2015
 CERTIFIED

ClearClock™ Oscillator Family | Low Jitter | 3.2x2.5mm XO

AX3

Request Samples



Check Inventory



ESD Sensitive



3.2 x 2.5 x 1.0 mm
RoHS/RoHS II Compliant
MSL Level = 1

RMS Phase Jitter 12kHz – 20MHz BW, Vdd=3.3V [Note 6, 7, 8]

Frequency (MHz)	Output	RMS Jitter	
		Typ. (fs)	Max (fs)
100	HCSL	153	200
	LVPECL	211	300
	LVDS	304	500
114.285	LVPECL	264	500
	LVDS	239	500
122.88	HCSL	122	200
	LVPECL	228	300
	LVDS	198	300
125	HCSL	138	200
	LVPECL	91	150
	LVDS	186	300
148.5	LVPECL	154	200
	LVDS	158	200
150	LVPECL	154	200
	LVDS	153	200
155.52	LVPECL	121	150
156.25	HCSL	113	150
	LVPECL	75	150
	LVDS	115	150
200	LVDS	70	150
	LVPECL	140	200
	HCSL	140	200
212.5	LVDS	60	150
	LVPECL	130	200
	HCSL	130	200

Note 6: Guaranteed by characterization; RMS Phase Jitter specifications are inclusive of any spurs

Note 7: Phase jitter measured with Keysight E5052B Signal Source Analyzer

Note 8: Refer to the next section for phase noise test setup and representative phase noise plots



5101 Hidden Creek Ln Spicewood TX 78669
Phone: 512-371-6159 | Fax: 512-351-8858
For terms and conditions of sales, please visit:
www.abracon.com

REVISED: 02-25-22

ABRACON IS
ISO9001-2015
CERTIFIED

ClearClock™ Oscillator Family | Low Jitter | 3.2x2.5mm XO

AX3

Request Samples



Check Inventory



ESD Sensitive



3.2 x 2.5 x 1.0 mm
RoHS/RoHS II Compliant
MSL Level = 1

Phase Noise Test Setup

- Keysight E5052B Signal Source Analyzer
- Integration Bandwidth = 12kHz to 20MHz
- Spurious Activity (entire plot trace) = Not omitted (Normalized in dBc/Hz)
- Specified Spur Omission Function = Not enabled
- IF Gain = 20dB
- Correlation = 5
- Average = 3



5101 Hidden Creek Ln Spicewood TX 78669
Phone: 512-371-6159 | Fax: 512-351-8858
For terms and conditions of sales, please visit:
www.abracon.com

REVISED: 02-25-22

ABRACON IS
ISO9001-2015
CERTIFIED

ClearClock™ Oscillator Family | Low Jitter | 3.2x2.5mm XO

AX3

Request Samples



Check Inventory



ESD Sensitive



3.2 x 2.5 x 1.0 mm

RoHS/RoHS II Compliant

MSL Level = 1

Representative Phase Noise Plots @ +25°C [Note 10]

F=156.2500MHz
Vdd=3.3V
LVPECL
RMS Phase Jitter = 75 fs

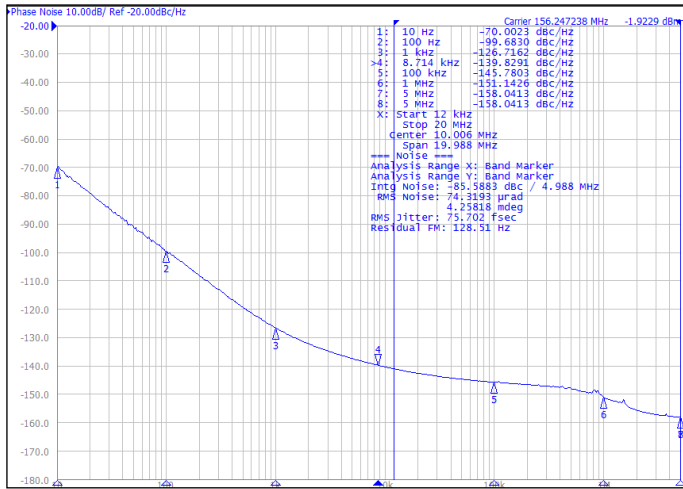

F=156.2500MHz
Vdd=3.3V
HCSL
RMS Phase Jitter = 113 fs

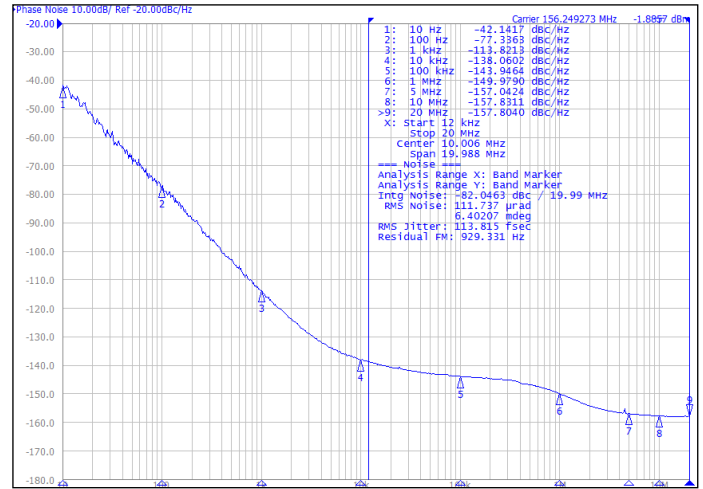

F=156.2500MHz
Vdd=3.3V
LVDS
RMS Phase Jitter = 115 fs

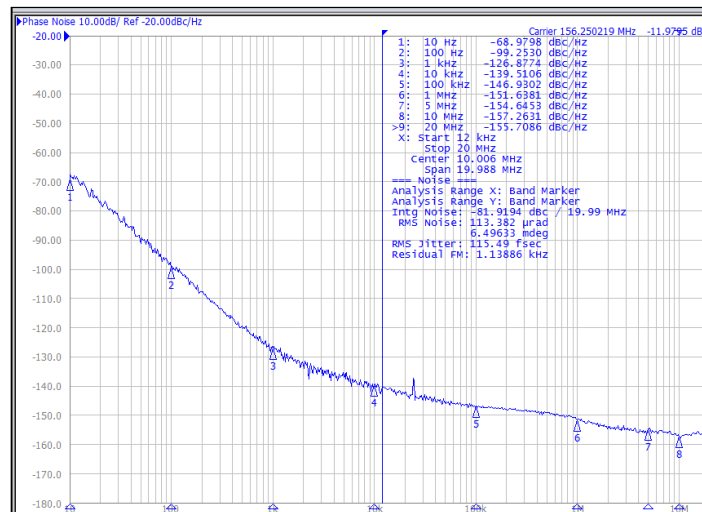

Note 9: Contact Abracon for phase noise plots at alternative supply voltage (V_{dd}) & differential output formats



5101 Hidden Creek Ln Spicewood TX 78669
 Phone: 512-371-6159 | Fax: 512-351-8858
 For terms and conditions of sales, please visit:
www.abracon.com

REVISED: 02-25-22

ABRACON IS
 ISO9001-2015
 CERTIFIED

ClearClock™ Oscillator Family | Low Jitter | 3.2x2.5mm XO

AX3

Request Samples



Check Inventory



ESD Sensitive



3.2 x 2.5 x 1.0 mm

RoHS/RoHS II Compliant

MSL Level = 1

F=100.0000MHz
Vdd=3.3V
LVPECL
RMS Phase Jitter = 211 fs

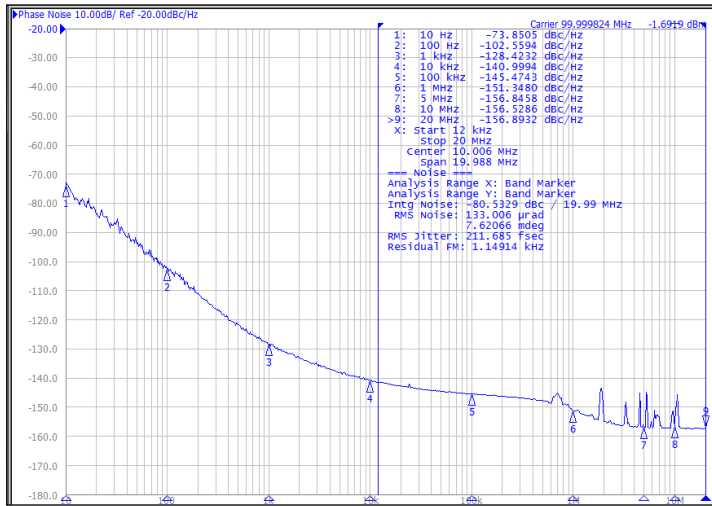

F=100.0000MHz
Vdd=3.3V
LVDS
RMS Phase Jitter = 304 fs

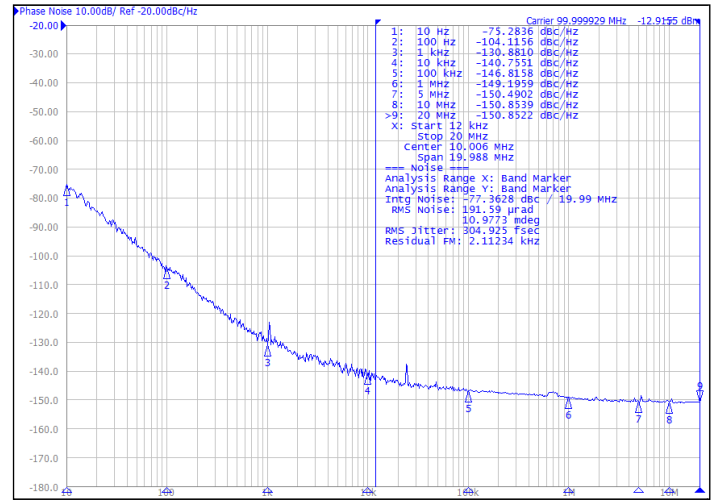

F=100.0000MHz
Vdd=3.3V
HCSL
RMS Phase Jitter = 153 fs

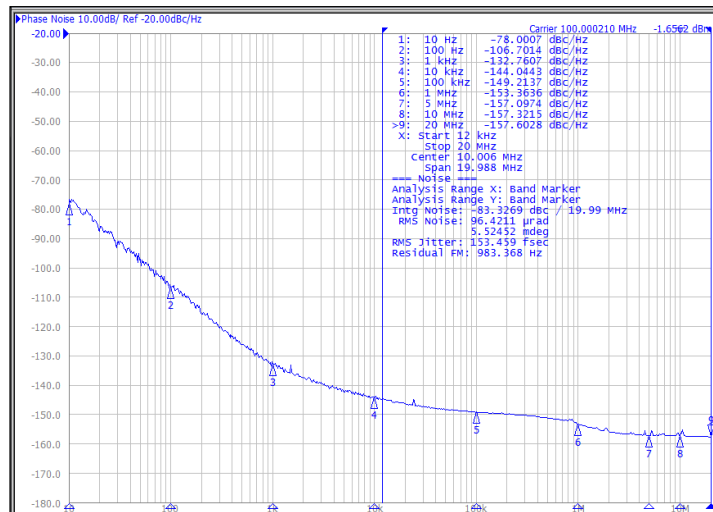

Note 9: Contact Abracon for phase noise plots at alternative supply voltage (V_{dd}) & differential output formats



5101 Hidden Creek Ln Spicewood TX 78669
 Phone: 512-371-6159 | Fax: 512-351-8858
 For terms and conditions of sales, please visit:
www.abracon.com

REVISED: 02-25-22

ABRACON IS
 ISO9001-2015
 CERTIFIED

ClearClock™ Oscillator Family | Low Jitter | 3.2x2.5mm XO

AX3

Request Samples



Check Inventory



ESD Sensitive



3.2 x 2.5 x 1.0 mm

RoHS/RoHS II Compliant

MSL Level = 1

F=125.0000MHz
Vdd=3.3V
LVDS
RMS Phase Jitter = 186 fs

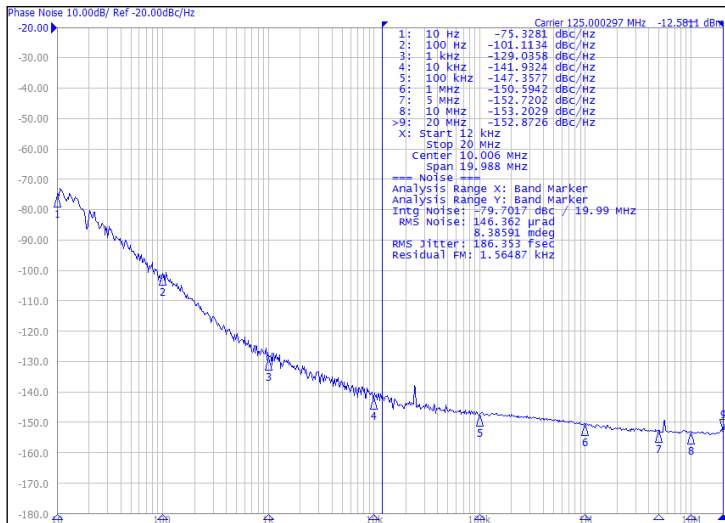

F=125.0000MHz
Vdd=3.3V
HCSL
RMS Phase Jitter = 138 fs

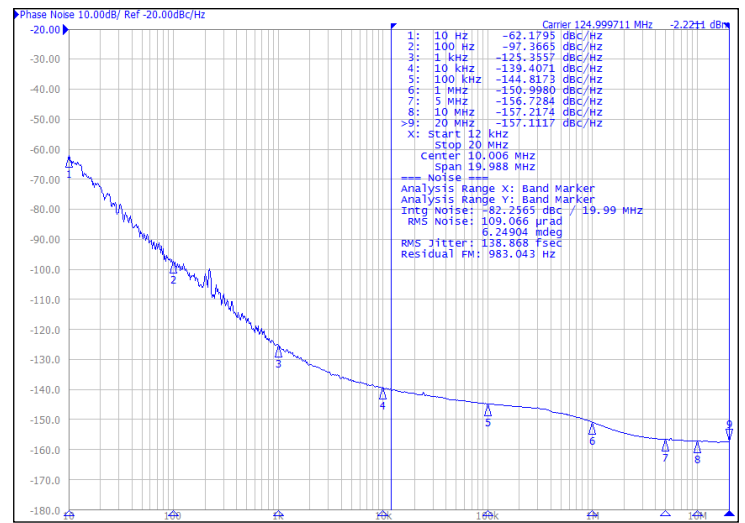

F=125.0000MHz
Vdd=3.3V
LVPECL
RMS Phase Jitter = 91 fs

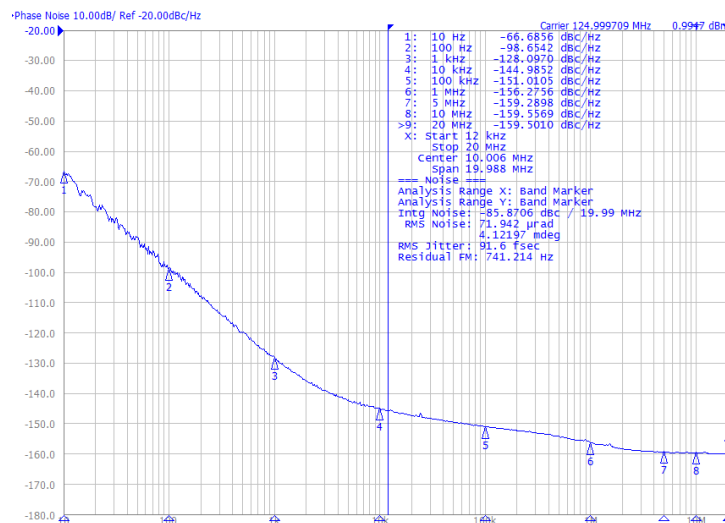

F=212.5000MHz
Vdd=3.3V
LVDS
RMS Phase Jitter = 57 fs

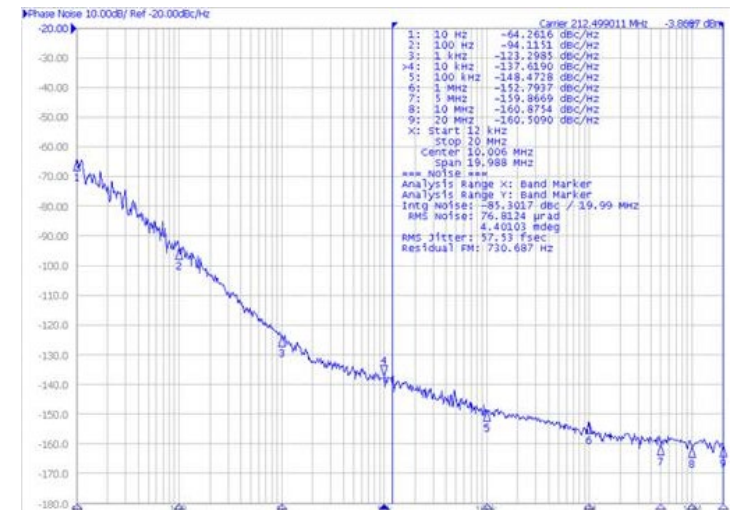

Note 9: Contact Abracon for phase noise plots at alternative supply voltage (V_{dd}) & differential output formats



5101 Hidden Creek Ln Spicewood TX 78669
 Phone: 512-371-6159 | Fax: 512-351-8858
 For terms and conditions of sales, please visit:
www.abracon.com

REVISED: 02-25-22

ABRACON IS
 ISO9001-2015
 CERTIFIED

ClearClock™ Oscillator Family | Low Jitter | 3.2x2.5mm XO

AX3

Request Samples



Check Inventory



ESD Sensitive



3.2 x 2.5 x 1.0 mm
RoHS/RoHS II Compliant
MSL Level = 1

Options and Part Identification [\[Note 1\]](#)

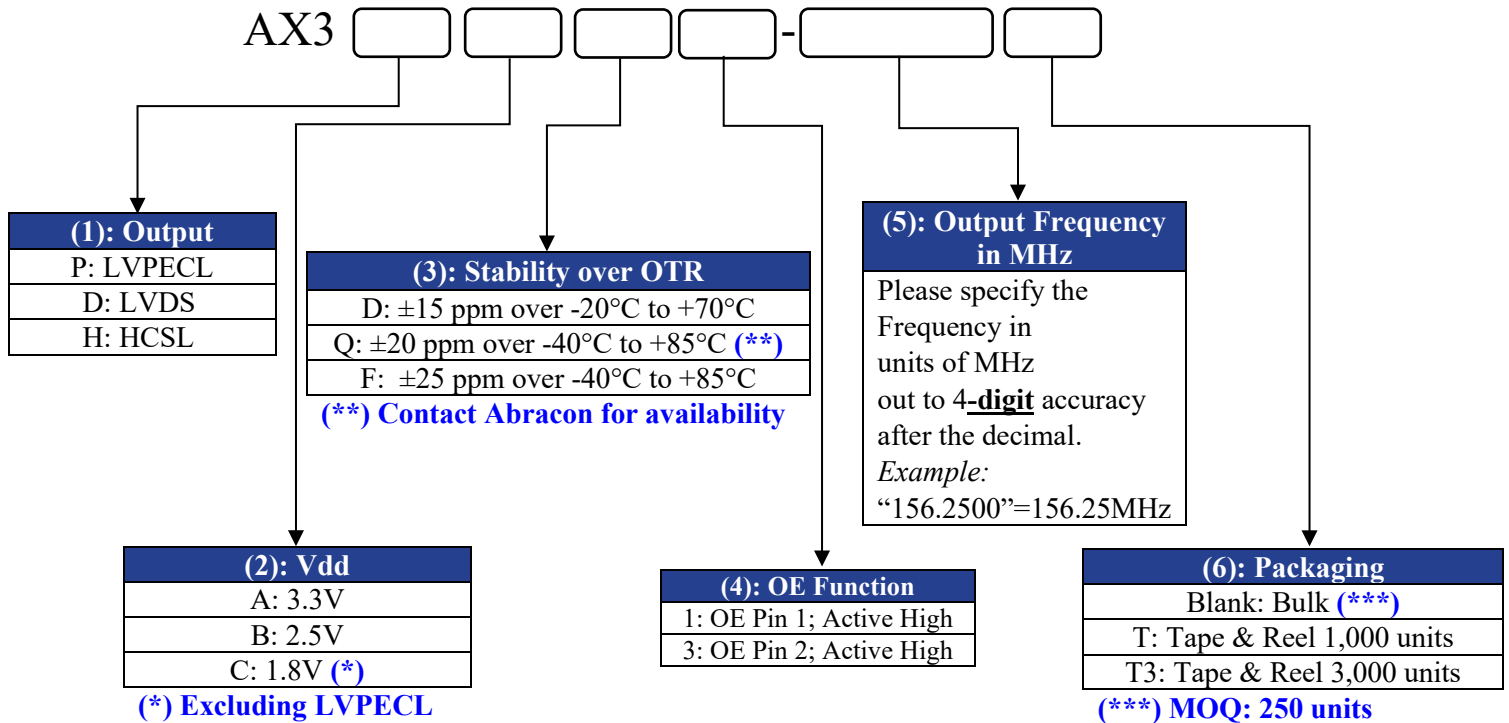

Part Number Example:

AX3PAF1-156.2500
AX3PAF1-156.2500T
AX3PAF1-156.2500T3

Note 1: Contact Abracon for non-standard part number configurations and/or requests with carrier frequency callouts up to 5 & 6 digit accuracy after the decimal



5101 Hidden Creek Ln Spicewood TX 78669
Phone: 512-371-6159 | Fax: 512-351-8858
For terms and conditions of sales, please visit:
www.abracon.com

REVISED: 02-25-22

ABRACON IS
ISO9001-2015
CERTIFIED

ClearClock™ Oscillator Family | Low Jitter | 3.2x2.5mm XO

AX3

Request Samples



Check Inventory



ESD Sensitive



3.2 x 2.5 x 1.0 mm
RoHS/RoHS II Compliant
MSL Level = 1

Typical Frequency vs. Temperature Characteristics

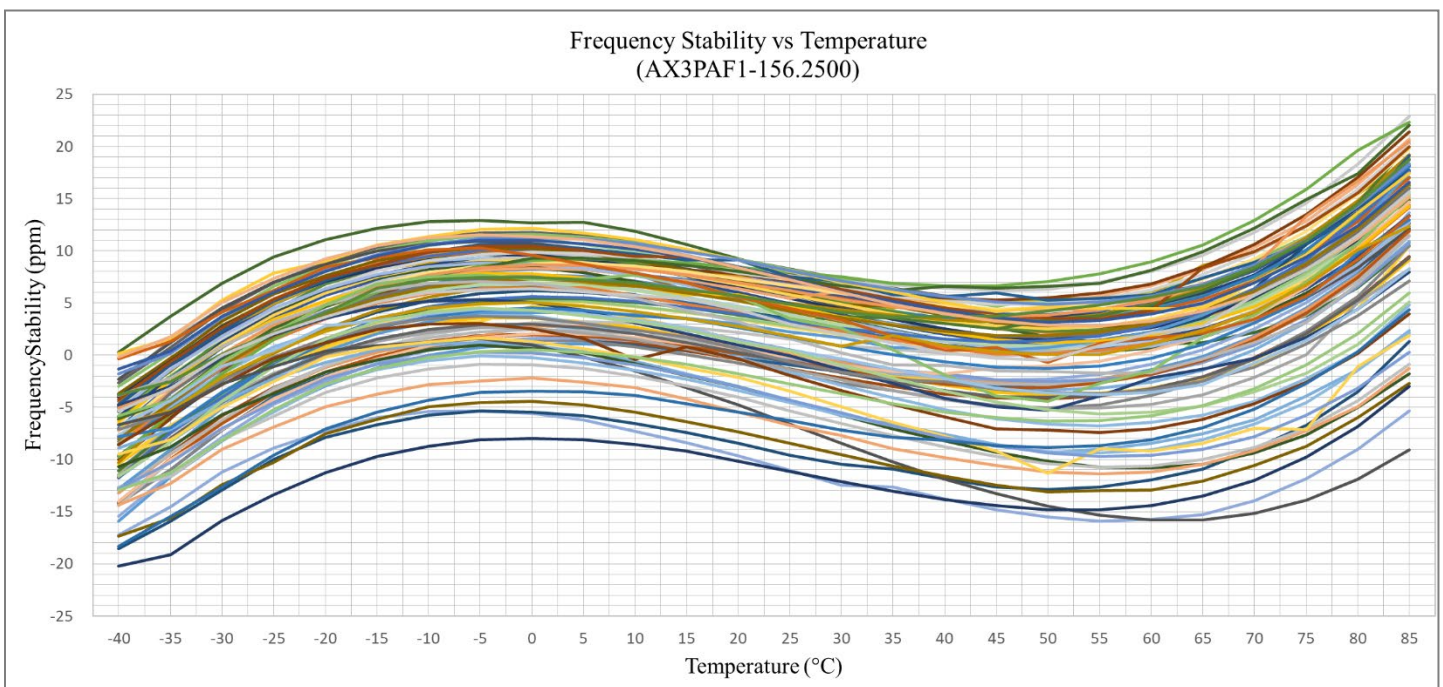
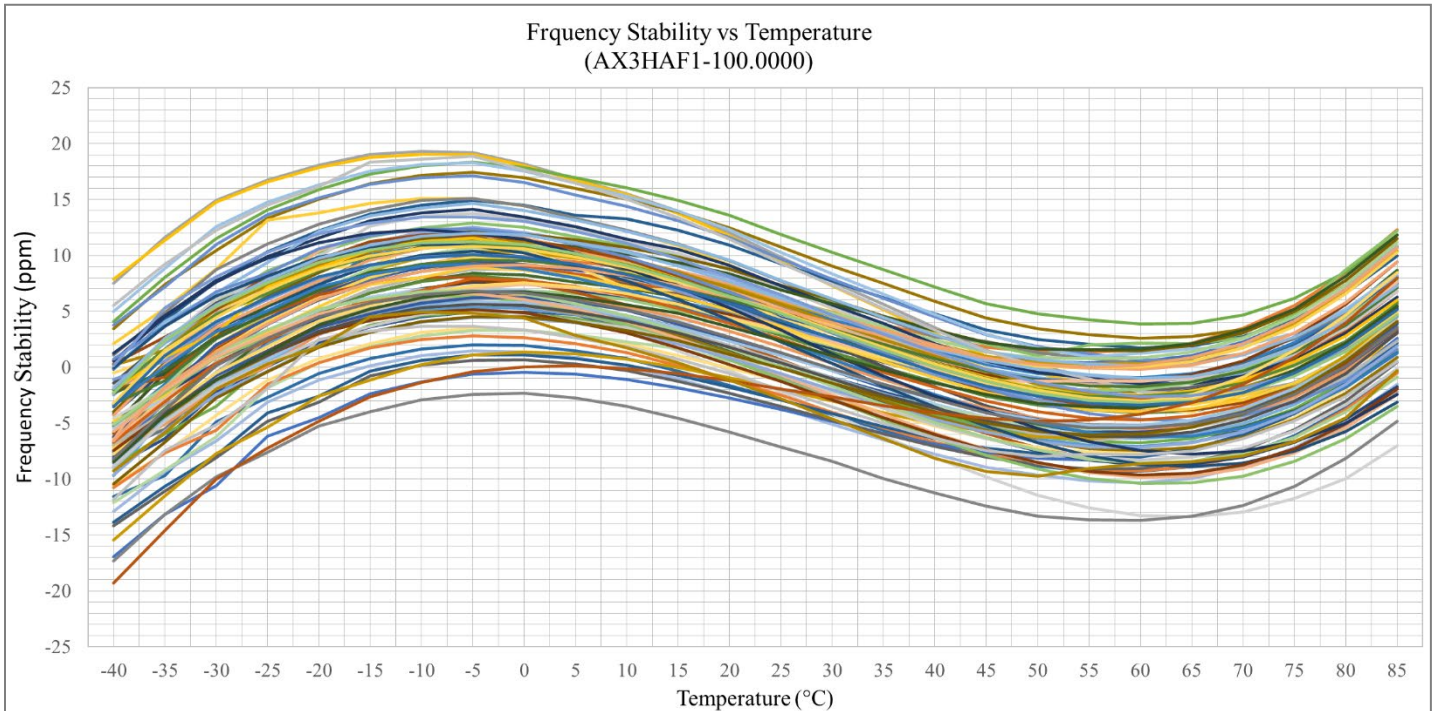

5101 Hidden Creek Ln Spicewood TX 78669
Phone: 512-371-6159 | Fax: 512-351-8858
For terms and conditions of sales, please visit:
www.abracon.com

REVISED: 02-25-22

ABRACON IS
ISO9001-2015
CERTIFIED

ClearClock™ Oscillator Family | Low Jitter | 3.2x2.5mm XO

AX3

Request Samples



Check Inventory



ESD Sensitive



3.2 x 2.5 x 1.0 mm
RoHS/RoHS II Compliant
MSL Level = 1

Differential Output Waveform

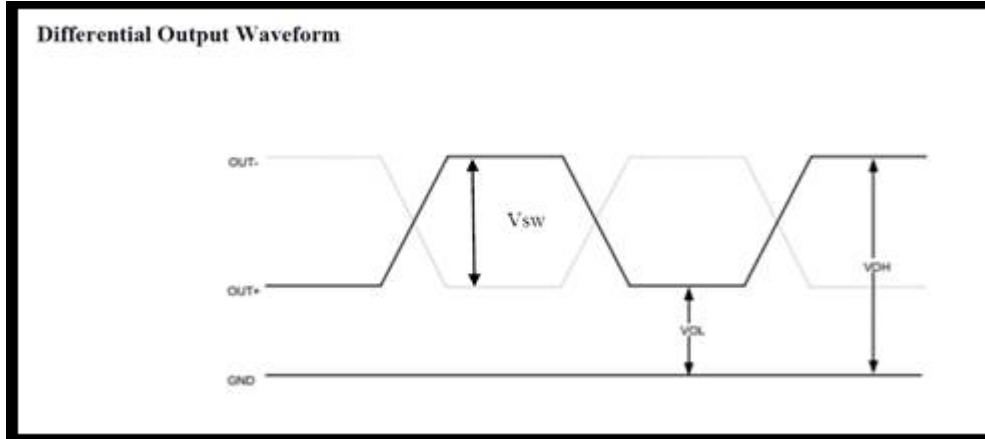

ClearClock™ Oscillator Family | Low Jitter | 3.2x2.5mm XO

AX3

Request Samples



Check Inventory



ESD Sensitive



3.2 x 2.5 x 1.0 mm
RoHS/RoHS II Compliant
MSL Level = 1

Recommended Test Circuit [\[Note 11\]](#)

LVPECL

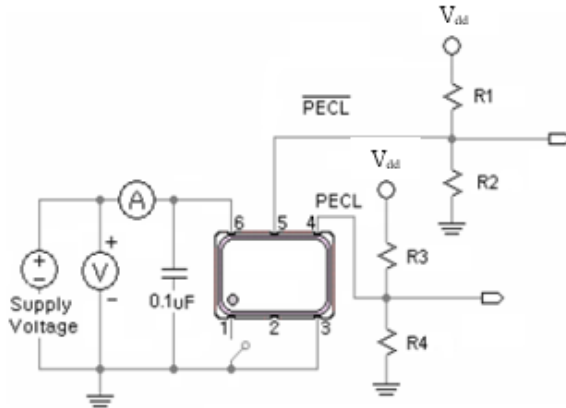

V_{dd}= 3.3V: R1=R3=127Ω; R2=R4=82.5Ω
V_{dd}= 2.5V: R1=R3=250Ω; R2=R4=62.5Ω

LVDS

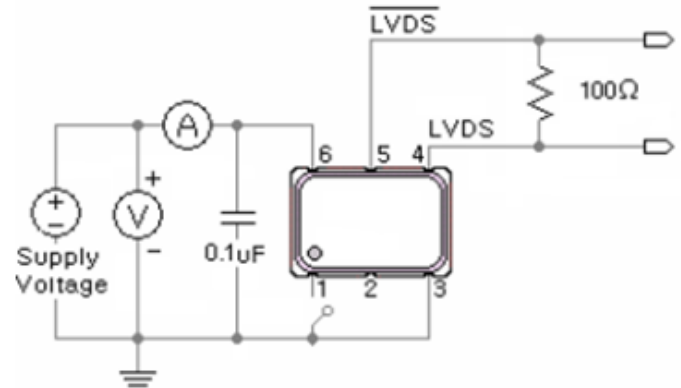

HCSL

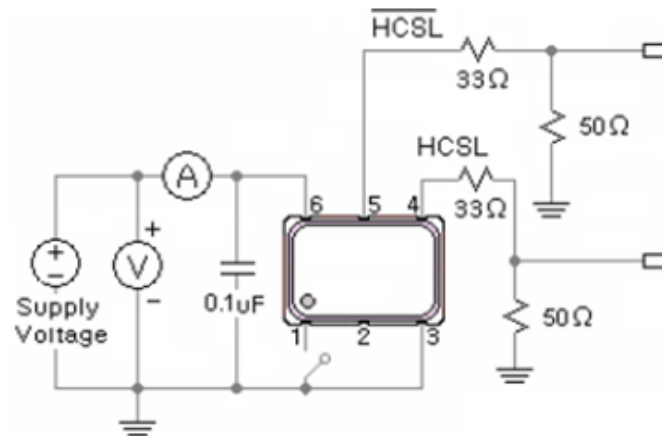

Note 11: Recommended test circuit images are representative of when the OE Function is located on Pin 1; when the OE Function is located on Pin 2, then Pin 1=No Connect & Pin 2=OE or No Connect.



5101 Hidden Creek Ln Spicewood TX 78669
Phone: 512-371-6159 | Fax: 512-351-8858
For terms and conditions of sales, please visit:
www.abracon.com

REVISED: 02-25-22

ABRACON IS
ISO9001-2015
CERTIFIED

ClearClock™ Oscillator Family | Low Jitter | 3.2x2.5mm XO

AX3

Request Samples



Check Inventory



ESD Sensitive



3.2 x 2.5 x 1.0 mm
RoHS/RoHS II Compliant
MSL Level = 1

Mechanical Dimensions

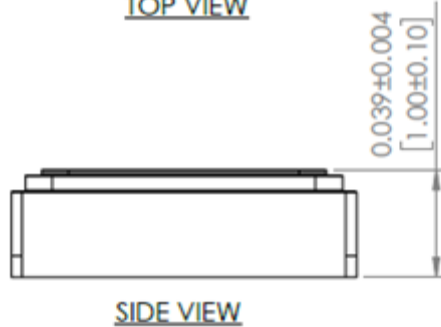
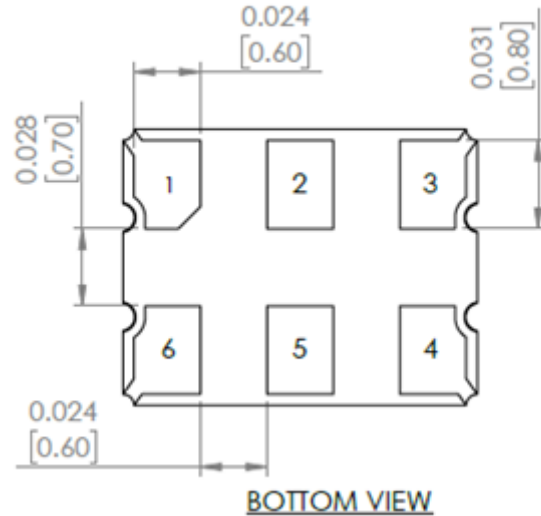
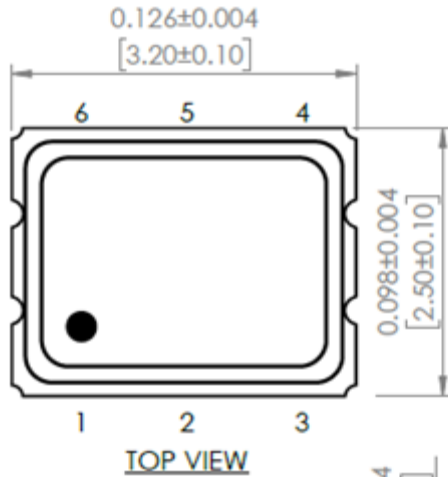

Recommended Land Pattern

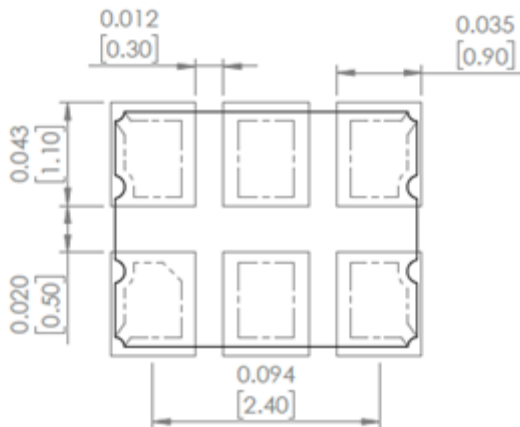

Dimensions: inches [mm]

Case 1 Pin #1=Output Enable/Disable Function where OE is Active HIGH		Case 2 Pin #2=Output Enable/Disable Function where OE is Active HIGH	
Pin	Description	Pin	Description
# 1	Output Enable = Logic High, "1", Vdd	# 1	No Connect
	Output Disable = Logic Low, "0", GND	# 2	Output Enable = Logic High, "1", Vdd
# 2	No Connect		Output Enable = Logic Low, "0", GND
# 3	GND	# 3	GND
# 4	Output	# 4	Output
# 5	Complementary output	# 5	Complementary output
# 6	Supply Voltage (Vdd)	# 6	Supply Voltage (Vdd)



5101 Hidden Creek Ln Spicewood TX 78669
Phone: 512-371-6159 | Fax: 512-351-8858
For terms and conditions of sales, please visit:
www.abracon.com

REVISED: 02-25-22

ABRACON IS
ISO9001-2015
CERTIFIED

ClearClock™ Oscillator Family | Low Jitter | 3.2x2.5mm XO

AX3

Request Samples



Check Inventory



ESD Sensitive



3.2 x 2.5 x 1.0 mm
RoHS/RoHS II Compliant
MSL Level = 1

Reflow Profile [JEDEC J-STD-020]

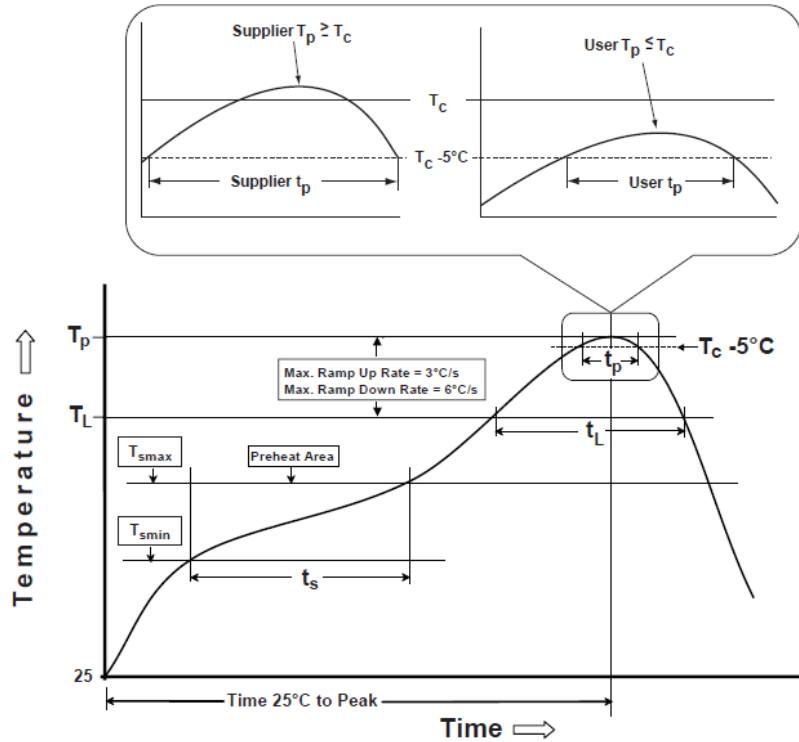

Table 1

SnPb Eutectic Process

Classification Temperatures (T_c)

Package Thickness	Volume mm ³ <350	Volume mm ³ ≥350
<2.5 mm	235 °C	220 °C
≥2.5 mm	220 °C	220 °C

Table 2

Pb-Free Process

Classification Temperatures (T_c)

Package Thickness	Volume mm ³ <350	Volume mm ³ 350-2000	Volume mm ³ >2000
<1.6 mm	260 °C	260 °C	260 °C
1.6 mm - 2.5 mm	260 °C	250 °C	245 °C
>2.5 mm	250 °C	245 °C	245 °C

Profile Feature	Sn-Pb Eutectic Assembly	Pb-Free Assembly
Preheat / soak		
Temperature minimum (T _{smin})	100°C	150°C
Temperature maximum (T _{smax})	150°C	200°C
Time (T _{smin} to T _{smax}) (t _s)	60 - 120 sec.	60 - 120 sec.
Average ramp-up rate (T _{smax} to T _p)	3°C/sec. max	3°C/sec. max
Liquidous temperature (T _L)	183°C	217°C
Time at liquidous (t _L)	60 - 150 sec.	60 - 150 sec.
Peak package body temperature (T _p)*	see Table 1	see Table 2
Time (t _p)** within 5°C of the specified classification temperature (T _c)	20 sec.	30 sec.
Ramp-down rate (T _p to T _{smax})	6°C/sec. max	6°C/sec. max
Time 25°C to peak temperature	6 min. max	8 min. max
Reflow cycles	2 max	2 max

*Tolerance for peak profile temperature (T_p) is defined as a supplier minimum and a user maximum.

**Tolerance for time at peak profile temperature (t_p) is defined as supplier minimum and a user maximum.



5101 Hidden Creek Ln Spicewood TX 78669
Phone: 512-371-6159 | Fax: 512-351-8858
For terms and conditions of sales, please visit:
www.abracon.com

REVISED: 02-25-22

ABRACON IS
ISO9001-2015
CERTIFIED

ClearClock™ Oscillator Family | Low Jitter | 3.2x2.5mm XO

AX3

Request Samples



Check Inventory



ESD Sensitive



3.2 x 2.5 x 1.0 mm
RoHS/RoHS II Compliant
MSL Level = 1

Packaging

Blank = Bulk (MOQ=250 units)
T = Tape & Reel 1,000 units/reel
T3 = Tape & Reel 3,000 units/reel

Feeding (PULL) Direction →

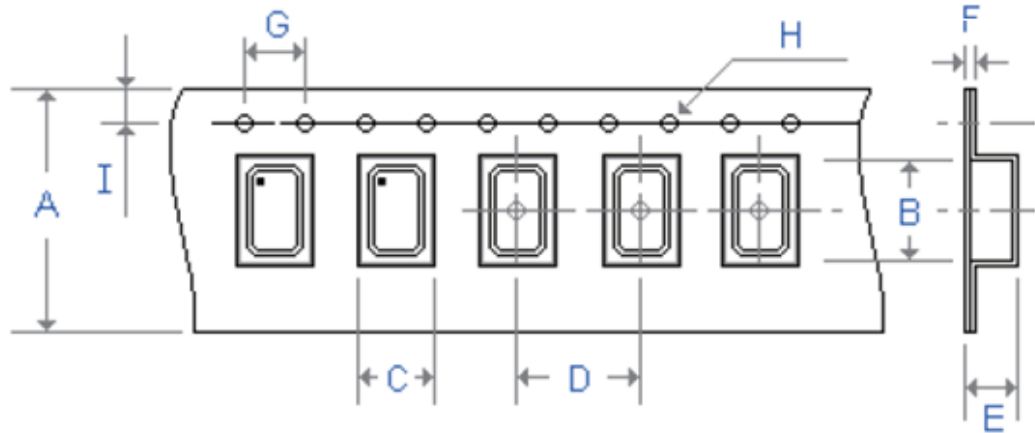

Tape Dimensions	
A	8.00
B	3.40
C	2.70
D	4.00
E	1.40
F	0.30
G	4.00
H	Ø1.55
I	1.75
Reel Dimensions	
J	180.00
K	10.90
L	11.40
M	13.20
N	2.20
O	22.00

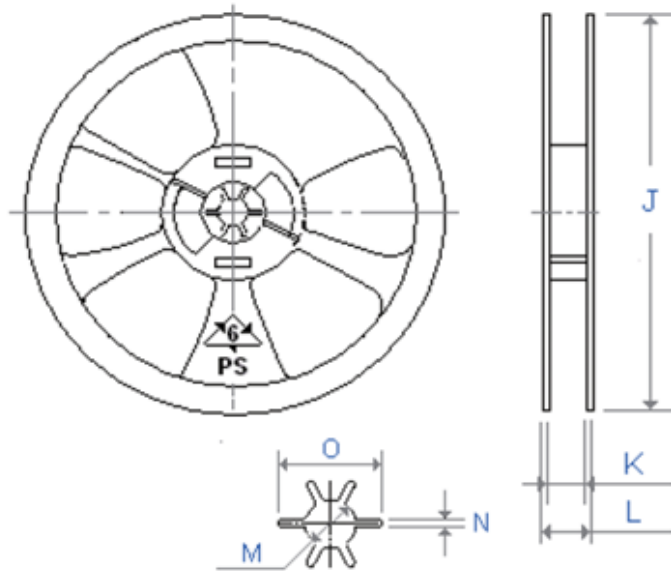

Dimensions: mm

ATTENTION: Abracon LLC's products are COTS – Commercial-Off-The-Shelf products; suitable for Commercial, Industrial and, where designated, Automotive Applications. Abracon's products are not specifically designed for Military, Aviation, Aerospace, Life-dependent Medical applications or any application requiring high reliability where component failure could result in loss of life and/or property. For applications requiring high reliability and/or presenting an extreme operating environment, written consent and authorization from Abracon LLC is required. Please contact Abracon LLC for more information.



5101 Hidden Creek Ln Spicewood TX 78669
Phone: 512-371-6159 | Fax: 512-351-8858
For terms and conditions of sales, please visit:
www.abracon.com

REVISED: 02-25-22

ABRACON IS
ISO9001-2015
CERTIFIED