

Rheostats

(Potentiometers) Wirewound

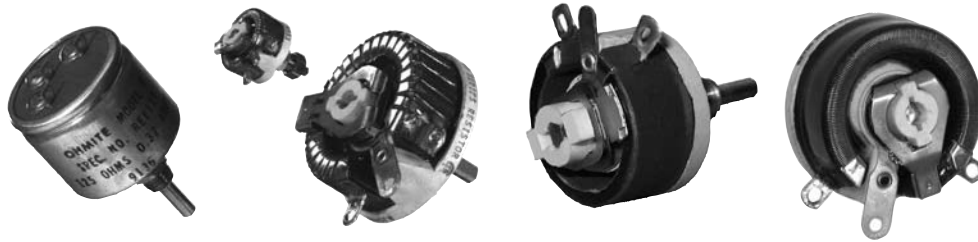

MODEL C

Model Type	Watts	Ohmic range	Core	Max. Voltage (RMS)*	Behind panel "B" (in./mm Ref.)	Diameter "D" (in./mm Ref.)	Dimension "C" (in./mm Ref.)	Shaft torque	Rotation (±5°)
C RCS/RCL	7.5	10.0-5K	enclosed	305	0.875/22.23	0.515/ 13.08	—	0.25-3 oz. in.	300°

• See Catalog #203 for complete details.

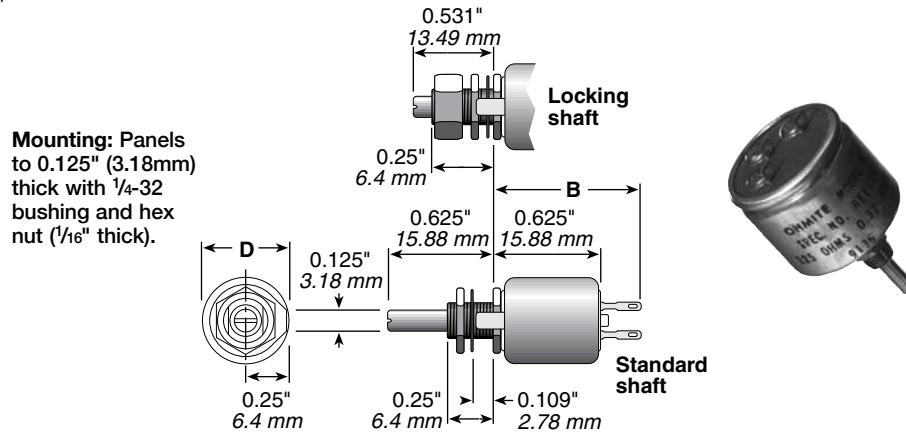

MODEL E

Model Type	Watts	Ohmic range	Core	Max. Voltage (RMS)*	Behind panel "B" (in./mm Ref.)	Diameter "D" (in./mm Ref.)	Dimension "C" (in./mm Ref.)	Shaft torque	Rotation (±5°)
E RES/REL	12.5	1.0-15K	open	305	0.688/17.46	0.875/ 22.23	0.594/15.08	1-6 oz. in.	300°
E REE	12.5	1.0-15K	enclosed	305	1.219/30.96	1.047/ 26.59	—	1-6 oz. in.	300°

• See Catalog #203 for complete details.

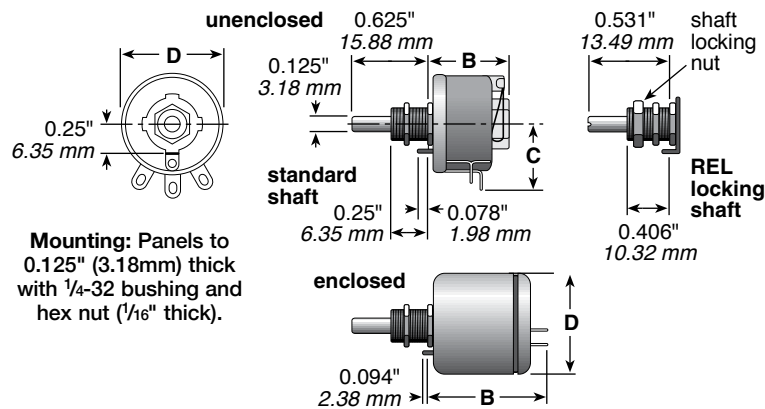

Dimensions for reference only; consult factory for details.

Since all rheostats/potentiometers are electro-mechanical devices, they are subject to mechanical wear and, therefore, have a finite life.

Models H, J, K, L and N are listed under UL File No. E-10946 and CSA File No. 21309 unless noted otherwise.

All rheostats are 10% tolerance.

Rheostats

(Potentiometers) Wirewound

MODELS H, J, G, K, L

Model	Type	Watts	Ohmic range	Core	Max. Voltage (RMS)*	Behind panel "B" (in./mm Ref.)	Diameter "D" (in./mm Ref.)	Dimension "C" (in./mm Ref.)	Shaft torque	Rotation (±5°)
H	RHS/RHL	25	1.0-25K	open	500	1.375/34.93	1.560/ 39.62	0.940/23.88	0.25-0.5 lb. in.	300°
J	RJS	50	0.5-50K	open	750	1.375/34.93	2.31 / 58.67	1.56 /39.62	0.25-2 lb. in.	300°
G	RGS	75	0.5-50K	open	900	1.750/44.45	2.75 / 69.25	1.78 /45.21	0.5-2 lb. in.	300°
K	RKS	100	0.5-50K	open	1000	1.750/44.45	3.125/ 79.38	1.91 /48.51	0.5-2 lb. in.	300°
L	RLS	150	0.5-50K	open	1200	2.000 / 50.8	4.00 /101.60	2.28 /57.91	0.5-3 lb. in.	300°

• Models H, J, G, and K also available in enclosed versions.

• See Catalog #203 for complete details.

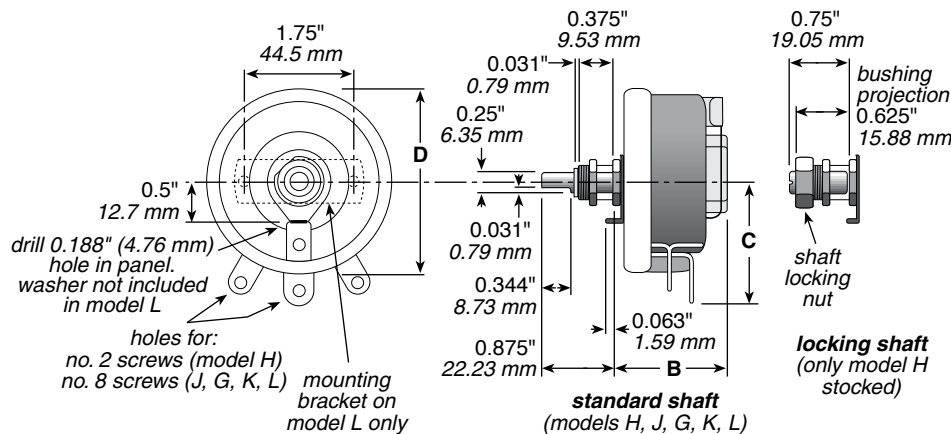

Mounting: Panels to 0.25" (6.35mm) thick with $\frac{3}{8}$ -32 bushing and hex nut ($\frac{3}{32}$ " thick) (or with 10-32 x 0.75 flat-head screws for model L only).

MODELS P, N, R, U

Model	Type	Watts	Ohmic range	Core	Max. Voltage (RMS)*	Behind panel "B" (in./mm Ref.)	Diameter "D" (in./mm Ref.)	Dimension "C" (in./mm Ref.)	Shaft torque	Rotation (±5°)
P	RPS	225	1.0-30K	open	1300	2.125/53.98	5.00 /127.00	2.97 /75.44	2.5-4 lb. in.	310°
N	RNS	300	1.0-50K	open	1225	2.375/60.33	6.00 /152.40	3.44 /87.38	2.5-5 lb. in.	320°
R	RRS	500	1.0-20K	open	1450	2.125/53.98	8.00 /203.20	4.31/109.47	4.5-7 lb. in.	325°
U	RUS	1000	1.0-20K	open	1600	3.000 / 76.2	12.00 /304.80	6.38/162.05	3.5-7 lb. in.	335°

• See Catalog #203 for complete details.

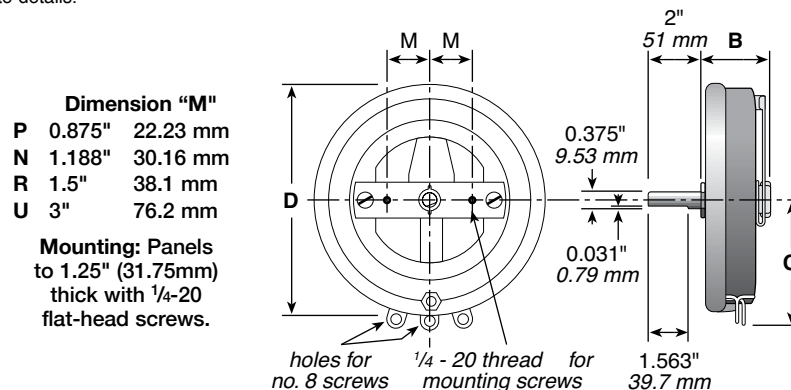

(continued)

