

**FEATURES****Supports multiband wireless applications**

- 3 bypassable, complex data input channels per RF DAC**
- 3.08 GSPS maximum complex input data rate per input channel**
- 1 independent NCO per input channel**

**Proprietary, low spurious and distortion design**

- 2-tone IMD3 = -83 dBc at 1.84 GHz, -7 dBFS/tone RF output**
- SFDR <-80 dBc at 1.84 GHz, -7 dBFS RF output**

**Flexible 8-lane, 15.4 Gbps JESD204B interface**

- Supports single-band and multiband use cases**
- Supports 12-bit high density mode for increased data throughput**

**Multiple chip synchronization**

- Supports JESD204B Subclass 1**

**Selectable interpolation filter for a complete set of input data rates**

- 1x, 2x, 3x, 4x, 6x, and 8x configurable data channel interpolation**
- 1x, 2x, 4x, 6x, 8x, and 12x configurable final interpolation**

**Final 48-bit NCO that operates at the DAC rate to support frequency synthesis up to 6 GHz****Transmit enable function allows extra power saving and downstream circuitry protection****High performance, low noise PLL clock multiplier**

- Supports 12.6 GSPS DAC update rate**
- Observation ADC clock driver with selectable divide ratios**

**Low power**

- 2.54 W with 2 DACs at 12 GSPS, DAC PLL on**
- 10 mm × 10 mm, 144-ball BGA\_ED with metal enhanced thermal lid, 0.80 mm pitch**

**APPLICATIONS****Wireless communications infrastructure**

- Multiband base station radios**
- Microwave/E-band backhaul systems**

**Instrumentation, automatic test equipment (ATE)****Radars and jammers****GENERAL DESCRIPTION**

The AD9174 is a high performance, dual, 16-bit digital-to-analog converter (DAC) that supports DAC sample rates up to 12.6 GSPS. The device features an 8-lane, 15.4 Gbps JESD204B data input port, a high performance, on-chip DAC clock multiplier, and digital signal processing capabilities targeted at single-band and multiband direct to radio frequency (RF) wireless applications.

The AD9174 features three complex data input channels per RF DAC datapath. Each input channel is fully bypassable. Each data input channel (or channelizer) includes a configurable gain stage, an interpolation filter, and a channel numerically controlled oscillator (NCO) for flexible, multiband frequency planning. The AD9174 supports an input data rate of up to a 3.08 GSPS complex (inphase/quadrature (I/Q)), or up to 6.16 GSPS non-complex (real), and is capable of allocating multiple complex input data streams to the assigned channels for individual processing. Each group of three channelizers is summed into a respective main datapath for additional processing when needed. Each main datapath includes an interpolation filter and one 48-bit main NCO ahead of the RF DAC core. Using the modulator switch, the outputs of a main datapath can be either routed to DAC0 alone for operating as a single DAC, or routed to both DAC0 and DAC1 for operating as a dual, intermediate frequency DAC (IF DAC).

The AD9174 also supports ultrawide data rate modes that allow bypassing the channelizers and main datapaths to provide maximum data rates of up to 6.16 GSPS as a single, 16-bit DAC, up to 3.08 GSPS as a dual, 16-bit DAC, or up to 4.1 GSPS as a dual, 12-bit DAC.

Additionally, the main NCO blocks in the AD9174 contain a bank of 31, 32-bit NCOs, each with an independent phase accumulator. Combined with a 80 MHz serial peripheral interface (SPI) for programming the NCOs, this bank allows a phase coherent, fast frequency hopping (FFH) for applications where the NCO frequencies are continuously adjusted during operation.

The AD9174 is available in a 144-ball BGA\_ED package.

**PRODUCT HIGHLIGHTS**

1. A low power, multichannel, dual DAC design reduces power consumption in higher bandwidth and multichannel applications, while maintaining performance.
2. Supports single-band and multiband wireless applications with three bypassable complex data channels per RF DAC, or configurations that use the two main datapaths as two wideband complex data channels when using the built in modulator switch.
3. A maximum complex data rate (per I or Q) of up to 3.08 GSPS with 16-bit resolution, and up to 4.1 GSPS with 12-bit resolution. The AD9174 can be alternatively configured as a dual DAC, with each DAC operating across an independent JESD204B link, at the previously described data rates.
4. Ultrawide bandwidth single-DAC modes, supporting up to 6.16 GSPS data rates with 16-bit resolution.

Rev. B

[Document Feedback](#)

Information furnished by Analog Devices is believed to be accurate and reliable. However, no responsibility is assumed by Analog Devices for its use, nor for any infringements of patents or other rights of third parties that may result from its use. Specifications subject to change without notice. No license is granted by implication or otherwise under any patent or patent rights of Analog Devices. Trademarks and registered trademarks are the property of their respective owners.

One Technology Way, P.O. Box 9106, Norwood, MA 02062-9106, U.S.A.  
Tel: 781.329.4700 ©2018–2019 Analog Devices, Inc. All rights reserved.  
[Technical Support](#) [www.analog.com](http://www.analog.com)

## TABLE OF CONTENTS

Features .....	1	JESD204B Serial Data Interface.....	33
Applications.....	1	JESD204B Overview .....	33
General Description .....	1	Physical Layer .....	37
Product Highlights .....	1	Data Link Layer .....	39
Revision History .....	2	Syncing LMFC Signals.....	41
Functional Block Diagram .....	4	Transport Layer .....	47
Specifications.....	5	JESD204B Test Modes .....	48
DC Specifications .....	5	JESD204B Error Monitoring.....	50
Digital Specifications .....	6	Digital Datapath .....	53
Maximum DAC Sampling Rate Specifications.....	6	Total Datapath Interpolation .....	53
Power Supply DC Specifications .....	7	Channel Digital Datapath .....	55
Serial Port and CMOS Pin Specifications .....	10	Main Digital Datapath.....	58
Digital Input Data Timing Specifications .....	11	NCO Only Mode .....	62
JESD204B Interface Electrical and Speed Specifications .....	12	Modulator Switch .....	64
Input Data Rates and Signal Bandwidth Specifications .....	13	Interrupt Request Operation .....	68
AC Specifications.....	14	Interrupt Service Routine.....	68
Absolute Maximum Ratings.....	16	Analog Interface .....	69
Reflow Profile.....	16	DAC Input Clock Configurations.....	69
Thermal Characteristics .....	16	Clock Output Driver .....	71
ESD Caution.....	16	Analog Outputs .....	71
Pin Configuration and Function Descriptions.....	17	Applications Information .....	73
Typical Performance Characteristics .....	20	Hardware Considerations .....	73
Terminology .....	28	Start-Up Sequence .....	76
Theory of Operation .....	29	Register Summary .....	83
Serial Port Operation .....	31	Register Details .....	95
Data Format .....	31	Outline Dimensions .....	165
Serial Port Pin Descriptions.....	31	Ordering Guide .....	165
Serial Port Options .....	32		

## REVISION HISTORY

### 7/2019—Rev. A to Rev. B

Changes to Digital Gain Section.....	55
Changes to Table 37.....	56
Changes to Table 43.....	60
Changes to NCO Only Mode Section.....	62
Changes to DAC Full-Scale Power Section.....	71
Changes to Table 56.....	79
Changes to Table 57.....	80
Changes to Table 62.....	105

### 5/2019—Rev. 0 to Rev. A

Change to Input Data Rate Per Input Channel Parameter, Table 8 .....	12
---	----

### Changes to Noise Spectral Density (NSD) Parameters,

Table 9 .....	13
Changes to Figure 16 Caption and Figure 17 Caption .....	21
Change to Table 17 .....	33
Changes to SYSREF± Sampling Section.....	41
Changes to Subclass 1 Section .....	42
Changes to Figure 73 and Table 37 .....	55
Change to Complex Modulator Switch Configurations Section.....	65
Changes to DAC On-Chip PL Section .....	69
Change to M_DIVIDER_1 Bit Description, Table 52 .....	75
Change to SPI_CHIPGRADE Register, Table 61 .....	82

Change to DATAPATH\_NCO\_SYNC\_CFG Register,  
Table 61 .....85  
Change to SPI\_CHIPGRADE Register, Table 62 .....94  
Changes to DATAPATH\_NCO\_SYNC\_CFG Register,  
Table 62 .....114

Changes to DACPLL\_CTRL1 Register, Table 62 .....155

**11/2018—Revision 0: Initial Version**

FUNCTIONAL BLOCK DIAGRAM

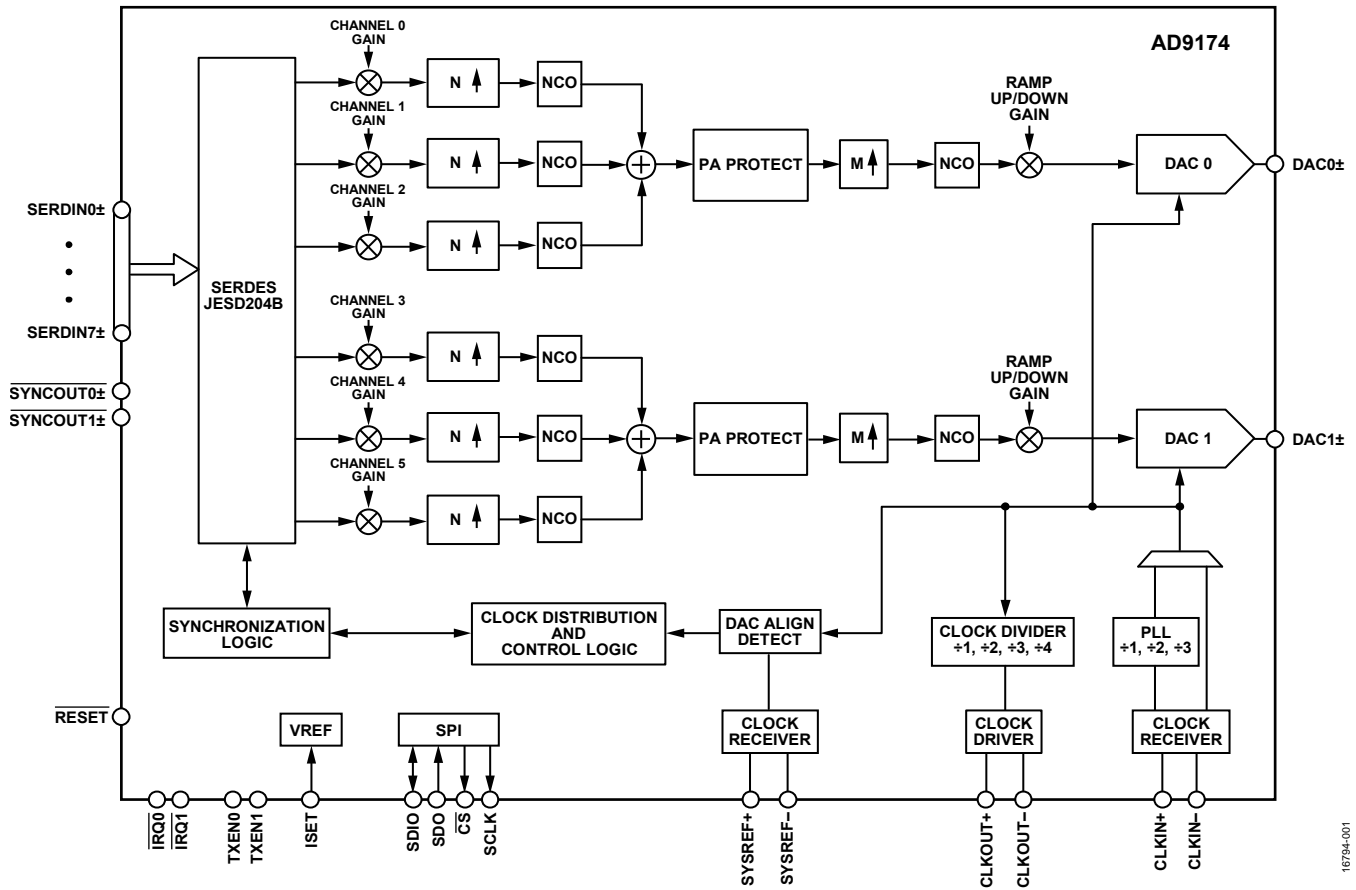

Figure 1.

16734-001

## SPECIFICATIONS

### DC SPECIFICATIONS

AVDD1.0 = 1.0 V, AVDD1.8 = 1.8 V, DVDD1.0 = 1.0 V, DVDD1.8 = 1.8 V, SVDD1.0 = 1.0 V, and DAC output full-scale current ( $I_{OUTFS}$ ) = 20 mA, unless otherwise noted. For the minimum and maximum values,  $T_j = -40^{\circ}\text{C}$  to  $+118^{\circ}\text{C}$ . For the typical values,  $T_A = 25^{\circ}\text{C}$ , which corresponds to  $T_j = 51^{\circ}\text{C}$ .

Table 1.

Parameter	Test Conditions/Comments	Min	Typ	Max	Unit
RESOLUTION		16			Bit
ACCURACY					
Integral Nonlinearity (INL)			±7		LSB
Differential Nonlinearity (DNL)			±7		LSB
ANALOG OUTPUTS (DAC0+, DAC0-, DAC1+, DAC1-)					
Gain Error (with Internal ISET Reference)			±15		%
Full-Scale Output Current					
Minimum	$R_{SET} = 5\text{ k}\Omega$	14.2	16	17.8	mA
Maximum	$R_{SET} = 5\text{ k}\Omega$	23.6	26	28.8	mA
Common-Mode Voltage			0		V
Differential Impedance			100		$\Omega$
DAC DEVICE CLOCK INPUT (CLKIN+, CLKIN-)					
Differential Input Power	$R_{LOAD} = 100\text{ }\Omega$ differential on-chip				
Minimum			0		dBm
Maximum			6		dBm
Differential Input Impedance <sup>1</sup>			100		$\Omega$
Common-Mode Voltage	AC-coupled		0.5		V
CLOCK OUTPUT DRIVER (CLKOUT+, CLKOUT-)					
Differential Output Power					
Minimum			-9		dBm
Maximum			0		dBm
Differential Output Impedance			100		$\Omega$
Common-Mode Voltage	AC-coupled		0.5		V
Output Frequency		727.5		3000	MHz
TEMPERATURE DRIFT					
Gain			10		ppm/ $^{\circ}\text{C}$
REFERENCE					
Internal Reference Voltage			0.495		V
ANALOG SUPPLY VOLTAGES					
AVDD1.0		0.95	1.0	1.05	V
AVDD1.8		1.71	1.8	1.89	V
DIGITAL SUPPLY VOLTAGES					
DVDD1.0		0.95	1.0	1.05	V
DAVDD1.0		0.95	1.0	1.05	V
DVDD1.8		1.71	1.8	1.89	V
SERIALIZER/DESERIALIZER (SERDES) SUPPLY VOLTAGES					
SVDD1.0		0.95	1.0	1.05	V

<sup>1</sup> See the DAC Input Clock Configurations section for more details.

**DIGITAL SPECIFICATIONS**

AVDD1.0 = 1.0 V, AVDD1.8 = 1.8 V, DVDD1.0 = 1.0 V, DVDD1.8 = 1.8 V, SVDD1.0 = 1.0 V, and DAC output full-scale current ( $I_{OUTFS}$ ) = 20 mA, unless otherwise noted. For the minimum and maximum values,  $T_j = -40^{\circ}\text{C}$  to  $+118^{\circ}\text{C}$ . For the typical values,  $T_A = +25^{\circ}\text{C}$ , which corresponds to  $T_j = 51^{\circ}\text{C}$ .

**Table 2.**

Parameter	Test Conditions/Comments	Min	Typ	Max	Unit
DAC UPDATE RATE					
Minimum				2.91	GSPS
Maximum <sup>1</sup>	16-bit resolution, with interpolation	12.6			GSPS
	16-bit resolution, no interpolation	6.16			GSPS
Adjusted <sup>2</sup>	16-bit resolution, with interpolation	3.08			GSPS
	16-bit resolution, no interpolation	6.16			GSPS
DAC PHASE-LOCKED LOOP (PLL) VOLTAGE CONTROLLED OSCILLATOR (VCO) FREQUENCY RANGES					
VCO Output Divide by 1		8.74		12.42	GSPS
VCO Output Divide by 2		4.37		6.21	GSPS
VCO Output Divide by 3		2.91		4.14	GSPS
PHASE FREQUENCY DETECT INPUT FREQUENCY RANGE		25		770	MHz
DAC DEVICE CLOCK INPUT (CLKIN+, CLKIN-) FREQUENCY RANGES					
PLL Off		2.91		12.6	GHz
PLL On	M divider set to divide by 1	25		770	MHz
	M divider set to divide by 2	50		1540	MHz
	M divider set to divide by 3	75		2310	MHz
	M divider set to divide by 4	100		3080	MHz

<sup>1</sup> The maximum DAC update rate varies depending on the selected JESD204B mode and the lane rate for the given configuration used. The maximum DAC rate according to lane rate and voltage supply levels is listed in Table 3.

<sup>2</sup> The adjusted DAC update rate is calculated as  $f_{DAC}$ , divided by the minimum required interpolation factor for a given mode or the maximum channel data rate for a given mode. Different modes have different maximum DAC update rates, minimum interpolation factors, and maximum channel data rates, as shown in Table 13.

**MAXIMUM DAC SAMPLING RATE SPECIFICATIONS**

AVDD1.0 = 1.0 V, AVDD1.8 = 1.8 V, DVDD1.0 = 1.0 V, DVDD1.8 = 1.8 V, SVDD1.0 = 1.0 V, and DAC output full-scale current ( $I_{OUTFS}$ ) = 20 mA, unless otherwise noted. For the minimum and maximum values,  $T_j = -40^{\circ}\text{C}$  to  $+118^{\circ}\text{C}$ . For the typical values,  $T_A = 25^{\circ}\text{C}$ , which corresponds to  $T_j = 51^{\circ}\text{C}$ .

**Table 3.**

Parameter	Test Conditions/Comments	Min	Typ	Max	Unit
MAXIMUM DAC UPDATE RATE					
SVDD1.0 = 1.0 V $\pm$ 5%	Lane rate > 11 Gbps	11.67			GSPS
	Lane rate $\leq$ 11 Gbps	12.37			GSPS
SVDD1.0 = 1.0 V $\pm$ 2.5%	Lane rate > 11 Gbps	11.79			GSPS
	Lane rate $\leq$ 11 Gbps <sup>1</sup>	12.6			GSPS

<sup>1</sup> If using the on-chip PLL, the maximum DAC speed is limited to the maximum PLL speed of 12.42 GSPS, as listed in Table 2.

**POWER SUPPLY DC SPECIFICATIONS**

AVDD1.0 = 1.0 V, AVDD1.8 = 1.8 V, DVDD1.0 = 1.0 V, DVDD1.8 = 1.8 V, SVDD1.0 = 1.0 V, and DAC output full-scale current ( $I_{OUTFS}$ ) = 20 mA, unless otherwise noted. For the minimum and maximum values,  $T_j = -40^{\circ}\text{C}$  to  $+118^{\circ}\text{C}$ . For the typical values,  $T_A = 25^{\circ}\text{C}$ , which corresponds to  $T_j = 51^{\circ}\text{C}$ .

**Table 4.**

Parameter	Test Conditions/Comments	Min	Typ	Max	Unit
<b>DUAL-LINK MODES</b>					
Mode 1 (L = 2, M = 4, NP = 16, N = 16)	11.7965 GSPS DAC rate, 184.32 MHz PLL reference clock, 32× total interpolation (4×, 8×), 40 MHz tone at $-3$ dBFS, channel gain = $-6$ dB, channel NCOs = $\pm 150$ MHz, main NCO = 2 GHz, SYNCOUTx± in LVDS mode				
AVDD1.0	All supply levels set to nominal values		725	1020	mA
	All supply levels set to 5% tolerance		775	1120	mA
AVDD1.8			110	130	mA
DVDD1.0	Combined current consumption with the DAVDD1.0 supply		1100	1670	mA
	All supply levels set to nominal values		1170	1850	mA
	All supplies at 5% tolerance		35	50	mA
DVDD1.8			290	510	mA
SVDD1.0	All supply levels set to nominal values		305	560	mA
	All supplies at 5% tolerance		2.37	3.38	W
Total Power Dissipation					
Mode 4 (L = 4, M = 4, NP = 16, N = 16)	11.7965 GSPS DAC rate, 491.52 MHz PLL reference clock, 24× total interpolation (3×, 8×), 40 MHz tone at $-3$ dBFS, channel gain = $-6$ dB, channel NCOs = $\pm 150$ MHz, main NCO = 2 GHz, SYNCOUTx± in LVDS mode				
AVDD1.0			725		mA
AVDD1.8			110		mA
DVDD1.0	Combined current consumption with the DAVDD1.0 supply		1150		mA
DVDD1.8			35		mA
SVDD1.0			425		mA
Total Power Dissipation			2.56		W
Mode 0 (L = 1, M = 2, NP = 16, N = 16)	5.89824 GSPS DAC rate, 184.32 MHz PLL reference clock, 16× total interpolation (2×, 8×), 40 MHz tone at $-3$ dBFS, channel NCO disabled, main NCO = 1.8425 GHz, SYNCOUTx± in LVDS mode				
AVDD1.0	All supply levels set to nominal values		400	670	mA
	All supplies at 5% tolerance		425	745	mA
AVDD1.8			110	130	mA
DVDD1.0	Combined current consumption with the DAVDD1.0 supply		570	960	mA
	All supply levels set to nominal values		610	1070	mA
	All supplies at 5% tolerance		35	50	mA
DVDD1.8			175	340	mA
SVDD1.0			1.40	2.15	W
Total Power Dissipation					

Parameter	Test Conditions/Comments	Min	Typ	Max	Unit
Mode 3 (L = 2, M = 2, NP = 16, N = 16)	11.7965 GSPS DAC rate, 184.32 MHz PLL reference clock, 24× total interpolation (3×, 8×), 40 MHz tone at –3 dBFS, channel NCO disabled, main NCO = 2.655 GHz, SYNCOUTx± in LVDS mode				
AVDD1.0	All supply levels set to nominal values		725		mA
	All supplies at 5% tolerance		775		mA
AVDD1.8			110		mA
DVDD1.0	Combined current consumption with the DAVDD1.0 supply				
	All supply levels set to nominal values		1020		mA
	All supplies at 5% tolerance		1070		mA
DVDD1.8			35		mA
SVDD1.0	All supply levels set to nominal values		245		mA
	All supplies at 5% tolerance		250		mA
Total Power Dissipation			2.25		W
Mode 9 (L = 4, M = 2, NP = 16, N = 16)	12 GSPS DAC rate, 187.5 MHz PLL reference clock, 8× total interpolation (1×, 8×), 10 MHz tone at –3 dBFS, channel NCO disabled, main NCO = 3.072 GHz, SYNCOUTx± in LVDS mode				
AVDD1.0	All supply levels set to nominal values		740	1030	mA
	All supplies at 5% tolerance		785	1135	mA
AVDD1.8			110	130	mA
DVDD1.0	Combined current consumption with the DAVDD1.0 supply				
	All supply levels set to nominal values		1010	1580	mA
	All supplies at 5% tolerance		1070	1740	mA
DVDD1.8			35	50	mA
SVDD1.0	All supply levels set to nominal values		530	840	mA
	All supplies at 5% tolerance		550	910	mA
Total Power Dissipation			2.54	3.63	W
Mode 2 (L = 3, M = 6, NP = 16, N = 16)	12 GSPS DAC rate, 375 MHz PLL reference clock, 48× total interpolation (6×, 8×), 30 MHz tone at –3 dBFS, channel gain = –11 dB, channel NCOs = 20 MHz, main NCO = 2.1 GHz				
AVDD1.0	All supply levels set to nominal values		735	1030	mA
	All supplies at 5% tolerance		785	1135	mA
AVDD1.8			110	130	mA
DVDD1.0	Combined current consumption with the DAVDD1.0 supply				
	All supply levels set to nominal values		1370	1800	mA
	All supplies at 5% tolerance		1460	1980	mA
DVDD1.8			35	50	mA
SVDD1.0	All supply levels set to nominal values		410	680	mA
	All supplies at 5% tolerance		430	755	mA
Total Power Dissipation			2.77	3.69	W
<b>SINGLE-LINK MODES</b>					
Mode 20 (L = 8, M = 1, NP = 16, N = 16)	6 GSPS DAC rate, 187.5 MHz PLL reference clock, 1× total interpolation (1×, 1×), 1.8 GHz tone at –3 dBFS, channel and main NCOs disabled				
AVDD1.0	All supply levels set to nominal values		400	670	mA
	All supplies at 5% tolerance		430	745	mA
AVDD1.8			75	100	mA
DVDD1.0	Combined current consumption with the DAVDD1.0 supply				
	All supply levels set to nominal values		390	700	mA
	All supplies at 5% tolerance		410	810	mA
DVDD1.8			35	50	mA
SVDD1.0	All supply levels set to nominal values		525	820	mA
	All supplies at 5% tolerance		550	880	mA

Parameter	Test Conditions/Comments	Min	Typ	Max	Unit
Total Power Dissipation			1.51	2.34	W
Mode 12 (L = 8, M = 2, NP = 12, N = 12)	4 GSPS DAC rate, 187.5 MHz PLL reference clock, 1× total interpolation (1×, 1×), 1 GHz tone at –3 dBFS, channel and main NCOs disabled				
AVDD1.0	All supply levels set to nominal values All supplies at 5% tolerance		300	550	mA
AVDD1.8			315	620	mA
DVDD1.0	Combined current consumption with the DAVDD1.0 supply All supply levels set to nominal values All supplies at 5% tolerance		75	100	mA
DVDD1.8			320	630	mA
SVDD1.0	All supply levels set to nominal values All supplies at 5% tolerance		350	725	mA
SVDD1.0			35	50	mA
SVDD1.0	All supply levels set to nominal values All supplies at 5% tolerance		525	820	mA
SVDD1.0			550	880	mA
Total Power Dissipation			1.34	2.15	W
DUAL-LINK, MODE 3 (NCO ONLY, SINGLE-CHANNEL MODE, NO SERDES)	6 GSPS DAC rate, 300 MHz PLL reference clock, 8× total interpolation (1×, 8×), no input tone (dc internal level = 0x50FF), channel NCO = 40 MHz, main NCO = 1.8425 GHz				
Mode 3					
AVDD1.0	All supply levels set to nominal values All supplies at 5% tolerance		410	660	mA
AVDD1.0			435	750	mA
AVDD1.8			110	130	mA
DVDD1.0	Combined current consumption with the DAVDD1.0 supply All supply levels set to nominal values All supplies at 5% tolerance		500	780	mA
DVDD1.0			515	950	mA
DVDD1.8			0.3	1	mA
SVDD1.0	All supply levels set to nominal values All supplies at 5% tolerance		5	100	mA
SVDD1.0			3	120	mA
Total Power Dissipation			1.11	1.671	W
DUAL-LINK, MODE 4 (NCO ONLY, DUAL-CHANNEL MODE, NO SERDES)	12 GSPS DAC rate, 500 MHz PLL reference clock, 32× total interpolation (4×, 8×), no input tone (dc internal level = 0x2AFF), channel NCOs = ±150 MHz, main NCO = 2 GHz				
Mode 4					
AVDD1.0	All supply levels set to nominal values All supplies at 5% tolerance		750	1030	mA
AVDD1.0			790	1130	mA
AVDD1.8			110	130	mA
DVDD1.0	Combined current consumption with the DAVDD1.0 supply All supply levels set to nominal values All supplies at 5% tolerance		1200	1590	mA
DVDD1.0			1300	1750	mA
DVDD1.8			0.3	1	mA
SVDD1.0	All supply levels set to nominal values All supplies at 5% tolerance		5	100	mA
SVDD1.0			5	100	mA
Total Power Dissipation			2.15	2.851	W

## SERIAL PORT AND CMOS PIN SPECIFICATIONS

AVDD1.0 = 1.0 V, AVDD1.8 = 1.8 V, DVDD1.0 = 1.0 V, DVDD1.8 = 1.8 V, SVDD1.0 = 1.0 V, and DAC output full-scale current ( $I_{OUTFS}$ ) = 20 mA, unless otherwise noted. For the minimum and maximum values,  $T_j = -40^{\circ}\text{C}$  to  $+118^{\circ}\text{C}$ . For the typical values,  $T_A = 25^{\circ}\text{C}$ , which corresponds to  $T_j = 51^{\circ}\text{C}$ .

Table 5.

Parameter	Symbol	Test Comments/Conditions	Min	Typ	Max	Unit
<b>WRITE OPERATION</b>						
Maximum SCLK Clock Rate	$f_{SCLK}, 1/t_{SCLK}$	See Figure 51	80			MHz
SCLK Clock High	$t_{PWH}$	SCLK = 20 MHz	5.03			ns
SCLK Clock Low	$t_{PWL}$	SCLK = 20 MHz	1.6			ns
SDIO to SCLK Setup Time	$t_{DS}$		1.154			ns
SCLK to SDIO Hold Time	$t_{DH}$		0.577			ns
$\overline{CS}$ to SCLK Setup Time	$t_s$		1.036			ns
SCLK to $\overline{CS}$ Hold Time	$t_H$		-5.3			ps
<b>READ OPERATION</b>						
SCLK Clock Rate	$f_{SCLK}, 1/t_{SCLK}$	See Figure 50			48.58	MHz
SCLK Clock High	$t_{PWH}$		5.03			ns
SCLK Clock Low	$t_{PWL}$		1.6			ns
SDIO to SCLK Setup Time	$t_{DS}$		1.158			ns
SCLK to SDIO Hold Time	$t_{DH}$		0.537			ns
$\overline{CS}$ to SCLK Setup Time	$t_s$		1.036			ns
SCLK to SDIO Data Valid Time	$t_{DV}$		9.6			ns
SCLK to SDO Data Valid Time	$t_{DV}$		13.7			ns
$\overline{CS}$ to SDIO Output Valid to High-Z		Not shown in Figure 50 or Figure 51	5.4			ns
$\overline{CS}$ to SDO Output Valid to High-Z		Not shown in Figure 50 or Figure 51	9.59			ns
<b>INPUTS (SDIO, SCLK, <math>\overline{CS}</math>, RESET, TXEN0, and TXEN1)</b>						
Voltage Input						
High	$V_{IH}$		1.48			V
Low	$V_{IL}$				0.425	V
Current Input						
High	$I_{IH}$				$\pm 100$	nA
Low	$I_{IL}$		$\pm 100$			nA
<b>OUTPUTS (SDIO, SDO)</b>						
Voltage Output						
High	$V_{OH}$					
0 mA load			1.69			V
4 mA load			1.52			V
Low	$V_{OL}$					
0 mA load					0.045	V
4 mA load					0.175	V
Current Output						
High	$I_{OH}$			4		mA
Low	$I_{OL}$			4		mA
<b>INTERRUPT OUTPUTS (IRQ0, IRQ1)</b>						
Voltage Output						
High	$V_{OH}$		1.71			V
Low	$V_{OL}$				0.075	V

**DIGITAL INPUT DATA TIMING SPECIFICATIONS**

AVDD1.0 = 1.0 V, AVDD1.8 = 1.8 V, DVDD1.0 = 1.0 V, DVDD1.8 = 1.8 V, SVDD1.0 = 1.0 V, and DAC output full-scale current ( $I_{OUTFS}$ ) = 20 mA, unless otherwise noted. For the minimum and maximum values,  $T_J = -40^{\circ}\text{C}$  to  $+118^{\circ}\text{C}$ . For the typical values,  $T_A = 25^{\circ}\text{C}$ , which corresponds to  $T_J = 51^{\circ}\text{C}$ .

**Table 6.**

Parameter	Test Conditions/Comments	Min	Typ	Max	Unit
<b>LATENCY<sup>1</sup></b>					
Channel Interpolation Factor, Main Datapath Interpolation Factor	LMFC_VAR_x = 12, LMFC_DELAY_x = 12, unless otherwise noted				
	JESD204B Mode 10, <sup>3</sup> Mode 18 <sup>3</sup>		420		DAC clock cycles
1x, 1x <sup>2</sup>	JESD204B Mode 11, Mode 19		440		DAC clock cycles
	JESD204B Mode 12, Mode 19		590		DAC clock cycles
	JESD204B Mode 20 <sup>3</sup>		700		DAC clock cycles
	JESD204B Mode 21		750		DAC clock cycles
1x, 2x <sup>2</sup>	JESD204B Mode 8 <sup>3</sup>		670		DAC clock cycles
	JESD204B Mode 9		700		DAC clock cycles
1x, 4x <sup>2</sup>	JESD204B Mode 8 <sup>3</sup>		1090		DAC clock cycles
	JESD204B Mode 9		1140		DAC clock cycles
1x, 6x <sup>2</sup>	JESD204B Mode 8 <sup>3</sup>		1460		DAC clock cycles
	JESD204B Mode 9		1530		DAC clock cycles
1x, 8x <sup>2</sup>	JESD204B Mode 3		1390		DAC clock cycles
	JESD204B Mode 8 <sup>3</sup>		1820		DAC clock cycles
	JESD204B Mode 9		1920		DAC clock cycles
1x, 12x <sup>2</sup>	JESD204B Mode 8 <sup>3</sup>		2700		DAC clock cycles
	JESD204B Mode 9		2840		DAC clock cycles
2x, 6x <sup>2</sup>	JESD204B Mode 3, Mode 4		1970		DAC clock cycles
	JESD204B Mode 5		1770		DAC clock cycles
2x, 8x <sup>2</sup>	JESD204B Mode 0		2020		DAC clock cycles
	JESD204B Mode 3, Mode 4		2500		DAC clock cycles
3x, 6x <sup>2</sup>	JESD204B Mode 3, Mode 4		2880		DAC clock cycles
	JESD204B Mode 5, Mode 6		2630		DAC clock cycles
3x, 8x <sup>2</sup>	JESD204B Mode 3, Mode 4		3310		DAC clock cycles
	JESD204B Mode 5, Mode 6		2980		DAC clock cycles
4x, 6x <sup>2</sup>	JESD204B Mode 0, Mode 1, Mode 2		2410		DAC clock cycles
4x, 8x <sup>2</sup>	JESD204B Mode 0, Mode 1, Mode 2		3090		DAC clock cycles
6x, 6x <sup>2</sup>	JESD204B Mode 0, Mode 1, Mode 2		3190		DAC clock cycles
6x, 8x <sup>2</sup>	JESD204B Mode 0, Mode 1, Mode 2		4130		DAC clock cycles
8x, 6x <sup>2</sup>	JESD204B Mode 7		3300		DAC clock cycles
8x, 8x <sup>2</sup>	JESD204B Mode 7		4270		DAC clock cycles
<b>DETERMINISTIC LATENCY</b>					
Fixed				13	PCLK <sup>4</sup>
Variable				2	PCLK cycles
<b>SYSREF<math>\pm</math> TO LMFC DELAY</b>			0		DAC clock cycles

<sup>1</sup> Total latency (or pipeline delay) through the device is calculated as follows: total latency = interface latency + fixed latency + variable latency + pipeline delay.

<sup>2</sup> The first value listed in this specification is the channel interpolation factor, and the second value is the main datapath interpolation factor.

<sup>3</sup> LMFC\_VAR\_x = 7 and LMFC\_DELAY\_x = 4

<sup>4</sup> PCLK is the internal processing clock for the AD9174 and equals the lane rate  $\div$  40.

**JESD204B INTERFACE ELECTRICAL AND SPEED SPECIFICATIONS**

AVDD1.0 = 1.0 V, AVDD1.8 = 1.8 V, DVDD1.0 = 1.0 V, DVDD1.8 = 1.8 V, SVDD1.0 = 1.0 V, and DAC output full-scale current ( $I_{OUTFS}$ ) = 20 mA, unless otherwise noted. For the minimum and maximum values,  $T_j = -40^\circ\text{C}$  to  $+118^\circ\text{C}$ . For the typical values,  $T_A = 25^\circ\text{C}$ , which corresponds to  $T_j = 51^\circ\text{C}$ .

**Table 7.**

Parameter	Symbol	Test Conditions/Comments	Min	Typ	Max	Unit
JESD204B SERIAL INTERFACE RATE (SERIAL LANE RATE)			3		15.4	Gbps
<b>JESD204B DATA INPUTS</b>						
Input Leakage Current		$T_A = 25^\circ\text{C}$				
Logic High		Input level = $1.0\text{ V} \pm 0.25\text{ V}$		10		$\mu\text{A}$
Logic Low		Input level = $0\text{ V}$		-4		$\mu\text{A}$
Unit Interval	UI		333		66.7	ps
Common-Mode Voltage	$V_{RCM}$	AC-coupled	-0.05		+1.1	V
Differential Voltage	$R_{V_{DIFF}}$		110		1050	mV
Differential Impedance	$Z_{R_{DIFF}}$	At dc	80	100	120	$\Omega$
<b>SYSREF<math>\pm</math> INPUT</b>						
Differential Impedance				100		$\Omega$
<b>DIFFERENTIAL OUTPUTS (SYNCOUT0<math>\pm</math>, SYNCOUT1<math>\pm</math>)<sup>1</sup></b>						
Output Differential Voltage	$V_{OD}$	Driving $100\ \Omega$ differential load	320	390	460	mV
Output Offset Voltage	$V_{OS}$		1.08	1.12	1.15	V
<b>SINGLE-ENDED OUTPUTS (SYNCOUT0<math>\pm</math>, SYNCOUT1<math>\pm</math>)</b>						
Output Voltage		Driving $100\ \Omega$ differential load				
High	$V_{OH}$		1.69			V
Low	$V_{OL}$				0.045	V
Current Output						
High	$I_{OH}$			0		mA
Low	$I_{OL}$			0		mA

<sup>1</sup> IEEE Standard 1596.3 LVDS compatible.

**INPUT DATA RATES AND SIGNAL BANDWIDTH SPECIFICATIONS**

AVDD1.0 = 1.0 V, AVDD1.8 = 1.8 V, DVDD1.0 = 1.0 V, DVDD1.8 = 1.8 V, SVDD1.0 = 1.0 V, and DAC output full-scale current ( $I_{OUTFS}$ ) = 20 mA, unless otherwise noted. For the minimum and maximum values,  $T_j = -40^{\circ}\text{C}$  to  $+118^{\circ}\text{C}$ . For the typical values,  $T_A = 25^{\circ}\text{C}$ , which corresponds to  $T_j = 51^{\circ}\text{C}$ .

**Table 8.**

Parameter <sup>1</sup>	Test Conditions/Comments	Min	Typ	Max	Unit
INPUT DATA RATE PER INPUT CHANNEL	Channel datapaths bypassed (1× interpolation), single-DAC mode, 16-bit resolution			6160	MSPS
	Channel datapaths bypassed (1× interpolation), dual DAC mode, 16-bit resolution			3080	MSPS
	Channel datapaths bypassed (1× interpolation), dual DAC mode, 12-bit resolution			4100	MSPS
	1 complex channel enabled			3080	MSPS
	2 complex channels enabled			770	MSPS
	3 complex channels enabled			385	MSPS
COMPLEX SIGNAL BANDWIDTH PER INPUT CHANNEL	1 complex channel enabled ( $0.8 \times f_{DATA}$ )			1232	MHz
	2 complex channels enabled ( $0.8 \times f_{DATA}$ )			616	MHz
	3 complex channels enabled ( $0.8 \times f_{DATA}$ )			308	MHz
MAXIMUM NCO CLOCK RATE	Channel NCO			1540	MHz
	Main NCO			12.6	GHz
MAXIMUM NCO SHIFT FREQUENCY RANGE	Channel NCO	Channel summing node = 1.575 GHz, channel interpolation rate > 1×	-770	+770	MHz
	Main NCO	$f_{DAC} = 12.6$ GHz, main interpolation rate > 1×	-6.3	+6.3	GHz
MAXIMUM FREQUENCY SPACING ACROSS INPUT CHANNELS	Maximum NCO output frequency × 0.8			1232	MHz

<sup>1</sup> Values listed for these parameters are the maximum possible when considering all JESD204B modes of operation. Some modes are more limiting, based on other parameters.

## AC SPECIFICATIONS

AVDD1.0 = 1.0 V, AVDD1.8 = 1.8 V, DVDD1.0 = 1.0 V, DVDD1.8 = 1.8 V, SVDD1.0 = 1.0 V, and DAC output full-scale current ( $I_{OUTFS}$ ) = 20 mA, unless otherwise noted. For the minimum and maximum,  $T_j = -40^\circ\text{C}$  to  $+118^\circ\text{C}$ . For the typical values,  $T_A = 25^\circ\text{C}$ , which corresponds to  $T_j = 51^\circ\text{C}$ .

Table 9.

Parameter	Test Conditions/Comments	Min	Typ	Max	Unit
<b>SPURIOUS-FREE DYNAMIC RANGE (SFDR)</b>					
Single Tone, $f_{DAC} = 12000$ MSPS, Mode 1 (L = 2, M = 4)	-7 dBFS, shuffle enabled				
$f_{OUT} = 100$ MHz			-81		dBc
$f_{OUT} = 500$ MHz			-80		dBc
$f_{OUT} = 950$ MHz			-75		dBc
$f_{OUT} = 1840$ MHz			-80		dBc
$f_{OUT} = 2650$ MHz			-75		dBc
$f_{OUT} = 3700$ MHz			-67		dBc
Single Tone, $f_{DAC} = 6000$ MSPS, Mode 0 (L = 1, M = 2)	-7 dBFS, shuffle enabled				
$f_{OUT} = 100$ MHz			-85		dBc
$f_{OUT} = 500$ MHz			-85		dBc
$f_{OUT} = 950$ MHz			-78		dBc
$f_{OUT} = 1840$ MHz			-75		dBc
$f_{OUT} = 2650$ MHz			-69		dBc
Single Tone, $f_{DAC} = 3000$ MSPS, Mode 10 (L = 8, M = 2)	-7 dBFS, shuffle enabled				
$f_{OUT} = 100$ MHz			-87		dBc
$f_{OUT} = 500$ MHz			-84		dBc
$f_{OUT} = 950$ MHz			-81		dBc
Single-Band Application—Band 3 (1805 MHz to 1880 MHz)	Mode 0, 2× to 8×, $f_{DAC} = 6000$ MSPS, 368.64 MHz reference clock				
SFDR Harmonics	-7 dBFS, shuffle enabled				
In-Band			-82		dBc
Digital Predistortion (DPD) Band	DPD bandwidth = data rate × 0.8		-80		dBc
Second Harmonic			-82		dBc
Third Harmonic			-80		dBc
Fourth and Fifth Harmonic			-95		dBc
SFDR Nonharmonics	-7 dBFS, shuffle enabled				
In-Band			-74		dBc
DPD Band			-74		dBc
<b>ADJACENT CHANNEL LEAKAGE RATIO</b>					
4-Channel WCDMA	-1 dBFS digital backoff				
$f_{DAC} = 1200$ MSPS, Mode 1 (L = 2, M = 4)	$f_{OUT} = 1840$ MHz		-70		dBc
	$f_{OUT} = 2650$ MHz		-68		dBc
	$f_{OUT} = 3500$ MHz		-66		dBc
$f_{DAC} = 6000$ MSPS, Mode 0 (L = 1, M = 2)	$f_{OUT} = 1840$ MHz		-71		dBc
	$f_{OUT} = 2650$ MHz		-66		dBc
<b>THIRD-ORDER INTERMODULATION DISTORTION (IMD3)</b>					
$f_{DAC} = 12000$ MSPS, Mode 1 (L = 2, M = 4)	Two-tone test, -7 dBFS/tone, 1 MHz spacing				
	$f_{OUT} = 1840$ MHz		-83		dBc
	$f_{OUT} = 2650$ MHz		-85		dBc
	$f_{OUT} = 3700$ MHz		-77		dBc
$f_{DAC} = 6000$ MSPS, Mode 0 (L = 1, M = 2)	$f_{OUT} = 1840$ MHz		-74		dBc
	$f_{OUT} = 2650$ MHz		-72		dBc

Parameter	Test Conditions/Comments	Min	Typ	Max	Unit
NOISE SPECTRAL DENSITY (NSD)	0 dBFS, NSD measurement taken at 10% away from $f_{OUT}$ , shuffle on				
Single Tone, $f_{DAC} = 12000$ MSPS					
$f_{OUT} = 200$ MHz			-163		dBc/Hz
$f_{OUT} = 500$ MHz			-163		dBc/Hz
$f_{OUT} = 950$ MHz			-162		dBc/Hz
$f_{OUT} = 1850$ MHz			-160		dBc/Hz
$f_{OUT} = 2150$ MHz			-158		dBc/Hz
Single Tone, $f_{DAC} = 6000$ MSPS					
$f_{OUT} = 200$ MHz			-164		dBc/Hz
$f_{OUT} = 500$ MHz			-163		dBc/Hz
$f_{OUT} = 950$ MHz			-161		dBc/Hz
$f_{OUT} = 1850$ MHz			-157		dBc/Hz
$f_{OUT} = 2150$ MHz			-155		dBc/Hz
Single Tone, $f_{DAC} = 3000$ MSPS					
$f_{OUT} = 200$ MHz			-163		dBc/Hz
$f_{OUT} = 500$ MHz			-159		dBc/Hz
$f_{OUT} = 950$ MHz			-155		dBc/Hz
SINGLE-SIDEBAND PHASE NOISE OFFSET	Loop filter component values according to Figure 90 are as follows: $C1 = 22$ nF, $R1 = 232$ $\Omega$ , $C2 = 2.4$ nF, $C3 = 33$ nF; PFD frequency = 500 MHz, $f_{OUT} = 1.8$ GHz, $f_{DAC} = 12$ GHz				
1 kHz			-97		dBc/Hz
10 kHz			-105		dBc/Hz
100 kHz			-114		dBc/Hz
600 kHz			-126		dBc/Hz
1.2 MHz			-133		dBc/Hz
1.8 MHz			-137		dBc/Hz
6 MHz			-148		dBc/Hz
DAC TO DAC OUTPUT ISOLATION	Taken using the <a href="#">AD9174-FMC-EBZ</a> evaluation board				
Dual Band— $f_{DAC} = 12000$ MSPS, Mode 1 ( $L = 2$ , $M = 4$ )					
$f_{OUT} = 1840$ MHz			-77		dB
$f_{OUT} = 2650$ MHz			-70		dB
$f_{OUT} = 3700$ MHz			-68		dB

## ABSOLUTE MAXIMUM RATINGS

Table 10.

Parameter	Rating
ISET, FILT_COARSE, FILT_BYP, FILT_VCM	−0.3 V to AVDD1.8 + 0.3 V
SERDIN <sub>x±</sub>	−0.2 V to SVDD1.0 + 0.2 V
SYNCOUT <sub>0±</sub> , SYNCOUT <sub>1±</sub> , RESET, TXEN <sub>0</sub> , TXEN <sub>1</sub> , IRQ <sub>0</sub> , IRQ <sub>1</sub> , CS, SCLK, SDIO, SDO	−0.3 V to DVDD1.8 + 0.3 V
DAC <sub>0±</sub> , DAC <sub>1±</sub> , CLKIN <sub>±</sub> , CLKOUT <sub>±</sub> , FILT_FINE	−0.2 V to AVDD1.0 + 0.2 V
SYSREF <sub>±</sub>	−0.2 V to DVDD1.0 + 0.2 V
AVDD1.0, DVDD1.0, SVDD1.0 to GND	−0.2 V to +1.2 V
AVDD1.8, DVDD1.8 to GND	−0.3 V to 2.2 V
Maximum Junction Temperature (T <sub>J</sub> ) <sup>1</sup>	118°C
Storage Temperature Range	−65°C to +150°C
Reflow	260°C

<sup>1</sup> Some operating modes of the device may cause the device to approach or exceed the maximum junction temperature during operation at supported ambient temperatures. Removal of heat from the device may require additional measures such as active airflow, heat sinks, or other measures.

Stresses at or above those listed under Absolute Maximum Ratings may cause permanent damage to the product. This is a stress rating only; functional operation of the product at these or any other conditions above those indicated in the operational section of this specification is not implied. Operation beyond the maximum operating conditions for extended periods may affect product reliability.

### REFLOW PROFILE

The AD9174 reflow profile is in accordance with the JEDEC JESD20 criteria for Pb-free devices. The maximum reflow temperature is 260°C.

### THERMAL CHARACTERISTICS

Thermal performance is directly linked to printed circuit board (PCB) design and operating environment. Careful attention to PCB thermal design is required.

$\theta_{JA}$  is the natural convection junction to ambient thermal resistance measured in a one cubic foot sealed enclosure.  $\theta_{JC}$  is the junction to case thermal resistance.

Thermal resistances and thermal characterization parameters are specified vs. the number of PCB layers in different airflow velocities (in m/sec). The use of appropriate thermal management techniques is recommended to ensure that the maximum junction temperature does not exceed the limits shown in Table 10.

Use the values in Table 11 in compliance with JEDEC 51-12.

Table 11. Simulated Thermal Resistance vs. PCB Layers<sup>1</sup>

PCB Type	Airflow Velocity (m/sec)	$\theta_{JA}$	$\theta_{JC\_TOP}$	$\theta_{JC\_BOT}$	Unit
JEDEC 2s2p Board	0.0	25.3	2.4 <sup>3</sup>	3.0 <sup>4</sup>	°C/W
	1.0	22.6	N/A	N/A	°C/W
	2.5	21.0	N/A	N/A	°C/W
12-Layer PCB <sup>2</sup>	0.0	15.4	2.4	2.6	°C/W
	1.0	13.1	N/A	N/A	°C/W
	2.5	11.6	N/A	N/A	°C/W

<sup>1</sup> N/A means not applicable.

<sup>2</sup> Non JEDEC thermal resistance.

<sup>3</sup> 1SOP PCB with no vias in PCB.

<sup>4</sup> 1SOP PCB with 7 × 7 standard JEDEC vias.

### ESD CAUTION



**ESD (electrostatic discharge) sensitive device.** Charged devices and circuit boards can discharge without detection. Although this product features patented or proprietary protection circuitry, damage may occur on devices subjected to high energy ESD. Therefore, proper ESD precautions should be taken to avoid performance degradation or loss of functionality.

### PIN CONFIGURATION AND FUNCTION DESCRIPTIONS

	1	2	3	4	5	6	7	8	9	10	11	12
A	GND	SERDIN7+	SERDIN6+	SERDIN5+	SERDIN4+	GND	GND	SERDIN3+	SERDIN2+	SERDIN1+	SERDIN0+	GND
B	GND	SERDIN7-	SERDIN6-	SERDIN5-	SERDIN4-	GND	GND	SERDIN3-	SERDIN2-	SERDIN1-	SERDIN0-	GND
C	SVDD1.0	SVDD1.0	GND	GND	SVDD1.0	DVDD1.8	SVDD1.0	SVDD1.0	GND	GND	SVDD1.0	SVDD1.0
D	SYNCOUT1+	SYNCOUT1-	DVDD1.8	TXEN1	GND	SVDD1.0	GND	TXEN0	IRQ0	DVDD1.8	SYNCOUT0-	SYNCOUT0+
E	DNC	DNC	DVDD1.8	SDO	SCLK	CS	SDIO	RESET	IRQ1	DVDD1.8	DNC	DNC
F	GND	GND	GND	DAVDD1.0	DVDD1.0	DVDD1.0	DVDD1.0	DVDD1.0	DAVDD1.0	GND	GND	GND
G	GND	GND	GND	GND	GND	GND	GND	GND	GND	GND	GND	GND
H	SYSREF+	SYSREF-	AVDD1.0	AVDD1.0	AVDD1.0	FILT_FINE	FILT_COARSE	AVDD1.0	AVDD1.0	AVDD1.0	GND	CLKIN-
J	GND	DNC	GND	GND	GND	AVDD1.0	FILT_BYP	GND	GND	GND	GND	CLKIN+
K	CLKOUT+	GND	AVDD1.8	DNC	AVDD1.8	FILT_VCM	AVDD1.8	GND	GND	AVDD1.8	GND	GND
L	CLKOUT-	GND	AVDD1.8	GND	GND	AVDD1.8	AVDD1.8	GND	GND	AVDD1.8	GND	ISET
M	GND	AVDD1.0	GND	DAC1+	DAC1-	GND	GND	DAC0-	DAC0+	GND	AVDD1.0	GND

■ GROUND     
 ■ SERDES INPUT     
 ■ 1.0V DIGITAL SUPPLY     
 ■ DAC PLL LOOP FILTER PINS     
 ■ CMOS I/O  
■ 1.0V ANALOG SUPPLY     
 ■ SYSREF±/SYNCOUTx±     
■ 1.0V DIGITAL/ANALOG SUPPLY     
 ■ DAC RF OUTPUTS     
 ■ REFERENCE  
■ 1.8V ANALOG SUPPLY     
■ 1.0V SERDES SUPPLY     
■ 1.8V DIGITAL SUPPLY     
■ RF CLOCK PINS

DNC = DO NOT CONNECT

Figure 2. Pin Configuration

16734-002

Table 12. Pin Function Descriptions

Pin No.	Mnemonic	Description
1.0V Supply H3, H4, H5, H8 to H10, J6, M2, M11	AVDD1.0	1.0 V Clock and Analog Supplies. These pins supply the clock receivers, clock distribution, the on-chip DAC clock multiplier, and the DAC analog core. Clean power supply rail sources are required on these pins.
F5 to F8	DVDD1.0	1.0 V Digital Supplies. These pins supply power to the DAC digital circuitry. Clean power supply rail sources are required on these pins.
F4, F9	DAVDD1.0	1.0 V Digital to Analog Supplies. These pins can share a supply rail with the DVDD1.0 supply (electrically connected) but must have separate supply plane and decoupling capacitors for the PCB layout to improve isolation for these two pins. Clean power supply rail sources are required on these pins.
C1, C2, C5, C7, C8, C11, C12, D6	SVDD1.0	1.0 V SERDES Supplies to the JESD204B Data Interface. Clean power supply rail sources are required on these pins.
1.8V Supply K3, K5, K7, K10, L3, L6, L7, L10	AVDD1.8	1.8 V Analog Supplies to the On-Chip DAC Clock Multiplier and the DAC Analog Core. Clean power supply rail sources are required on these pins.
C6, D3, D10, E3, E10	DVDD1.8	1.8 V Digital Supplies to the JESD204B Data Interface and the Other Input/Output Circuitry, Such as the SPI. Clean power supply rail sources are required on these pins.

Pin No.	Mnemonic	Description
Ground A1, A6, A7, A12, B1, B6, B7, B12, C3, C4, C9, C10, D5, D7, F1 to F3, F10 to F12, G1 to G12, H11, J1, J3 to J5, J8 to J11, K2, K8, K9, K11, K12, L2, L4, L5, L8, L9, L11, M1, M3, M6, M7, M10, M12	GND	Device Common Ground.
RF Clock J12	CLKIN+	Positive Device Clock Input. This pin is the clock input for the on-chip DAC clock multiplier, REFCLK, when the DAC PLL is on. This pin is also the clock input for the DAC sample clock or device clock (DACCLK) when the DAC PLL is off. AC couple this input. There is an internal 100 $\Omega$ resistor between this pin and CLKIN-.
H12	CLKIN-	Negative Device Clock Input.
K1	CLKOUT+	Positive Device Clock Output. This pin is the clock output of a divided down DACCLK and is available with the DAC PLL on and off. The divide down ratios are by 1, 2, 3, or 4.
L1	CLKOUT-	Negative Device Clock Output.
System Reference H1	SYSREF+	Positive System Reference Input. It is recommended to ac couple this pin, but dc coupling is also acceptable. See the SYSREF $\pm$ specifications for the dc common-mode voltage.
H2	SYSREF-	Negative System Reference Input. It is recommended to ac couple this pin, but dc coupling is also acceptable. See the SYSREF $\pm$ specifications for the dc common-mode voltage.
On-Chip DAC PLL Loop Filter H6	FILT_FINE	On-Chip DAC Clock Multiplier and PLL Fine Loop Filter Input. If the PLL is not in use, leave this pin floating and disable the PLL via the control registers.
H7	FILT_COARSE	On-Chip DAC Clock Multiplier and PLL Coarse Loop Filter Input. If the PLL is not in use, leave this pin floating and disable the PLL via the control registers.
J7	FILT_BYP	On-Chip DAC Clock Multiplier and LDO Bypass. Add a high quality ceramic bypass capacitor between 2 $\mu$ F and 10 $\mu$ F at this node. Ideally this capacitor is 10 $\mu$ F X7R or better. If the PLL is not in use, leave this pin floating and disable the PLL via the control registers.
K6	FILT_VCM	On-Chip DAC Clock Multiplier and VCO Common-Mode Input. If the PLL is not in use, leave this pin floating and disable the PLL via the control registers.
SERDES Data Bits A2	SERDIN7+	SERDES Data Bit 7, Positive.
B2	SERDIN7-	SERDES Data Bit 7, Negative.
A3	SERDIN6+	SERDES Data Bit 6, Positive.
B3	SERDIN6-	SERDES Data Bit 6, Negative.
A4	SERDIN5+	SERDES Data Bit 5, Positive.
B4	SERDIN5-	SERDES Data Bit 5, Negative.
A5	SERDIN4+	SERDES Data Bit 4, Positive.
B5	SERDIN4-	SERDES Data Bit 4, Negative.
A8	SERDIN3+	SERDES Data Bit 3, Positive.
B8	SERDIN3-	SERDES Data Bit 3, Negative.
A9	SERDIN2+	SERDES Data Bit 2, Positive.
B9	SERDIN2-	SERDES Data Bit 2, Negative.
A10	SERDIN1+	SERDES Data Bit 1, Positive.
B10	SERDIN1-	SERDES Data Bit 1, Negative.
A11	SERDIN0+	SERDES Data Bit 0, Positive.
B11	SERDIN0-	SERDES Data Bit 0, Negative.

Pin No.	Mnemonic	Description
Sync Output		
D12	$\overline{\text{SYNCOUT0+}}$	Positive Sync (Active Low) Output Signal, Channel Link 0. This pin is LVDS or CMOS selectable.
D11	$\overline{\text{SYNCOUT0-}}$	Negative Sync (Active Low) Output Signal, Channel Link 0. This pin is LVDS or CMOS selectable.
D1	$\overline{\text{SYNCOUT1+}}$	Positive Sync (Active Low) Output Signal, Channel Link 1. This pin is LVDS or CMOS selectable.
D2	$\overline{\text{SYNCOUT1-}}$	Negative Sync (Active Low) Output Signal, Channel Link 1. This pin is LVDS or CMOS selectable.
Serial Port Interface		
E4	SDO	Serial Port Data Output (CMOS Levels with Respect to DVDD1.8).
E7	SDIO	Serial Port Data Input/Output (CMOS Levels with Respect to DVDD1.8).
E5	SCLK	Serial Port Clock Input (CMOS Levels with Respect to DVDD1.8).
E6	$\overline{\text{CS}}$	Serial Port Chip Select, Active Low (CMOS Levels with Respect to DVDD1.8).
E8	$\overline{\text{RESET}}$	Reset, Active Low (CMOS Levels with Respect to DVDD1.8).
Interrupt Request		
D9	$\overline{\text{IRQ0}}$	Interrupt Request 0. This pin is an open-drain, active low output (CMOS levels with respect to DVDD1.8). Connect a pull-up resistor to DVDD1.8 to prevent this pin from floating when inactive.
E9	$\overline{\text{IRQ1}}$	Interrupt Request 1. This pin is an open-drain, active low output (CMOS levels with respect to DVDD1.8). Connect a pull-up resistor to DVDD1.8 to prevent this pin from floating when inactive.
CMOS Input/Outputs		
D8	TXEN0	Transmit Enable for DAC0. The CMOS levels are determined with respect to DVDD1.8.
D4	TXEN1	Transmit Enable for DAC1. The CMOS levels are determined with respect to DVDD1.8.
DAC Analog Outputs		
M9	DAC0+	DAC0 Positive Current Output.
M8	DAC0-	DAC0 Negative Current Output.
M4	DAC1+	DAC1 Positive Current Output.
M5	DAC1-	DAC1 Negative Current Output.
Reference		
L12	ISET	Device Bias Current Setting Pin. Connect a 5 k $\Omega$ resistor from this pin to GND, preferably with <0.1% tolerance and $\pm 25$ ppm/ $^{\circ}\text{C}$ temperature coefficient.
Do Not Connect		
E1, E2, E11, E12, J2, K4	DNC	Do Not Connect. Do not connect to these pins.

### TYPICAL PERFORMANCE CHARACTERISTICS

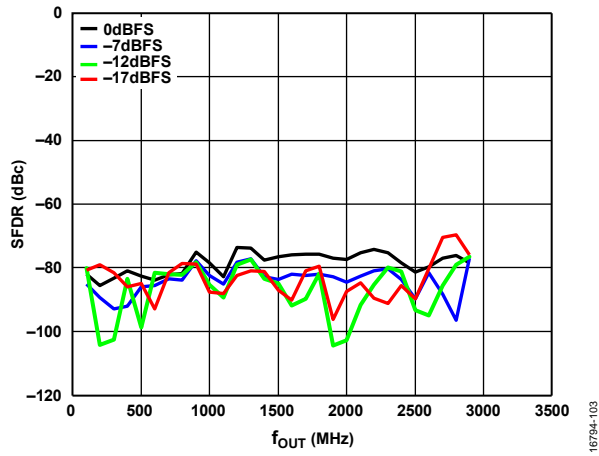

Figure 3. Second Harmonic (SFDR) vs.  $f_{OUT}$  over Digital Scale (Mode 0), 6 GHz DAC Sample Rate, Channel Interpolation 2x, Main Interpolation 8x

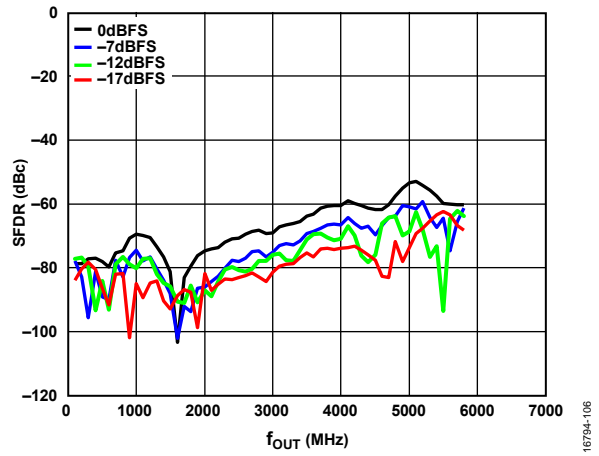

Figure 6. Second Harmonic (SFDR) vs.  $f_{OUT}$  over Digital Scale (Mode 1), 12 GHz DAC Sample Rate, Channel Interpolation 4x, Main Interpolation 8x

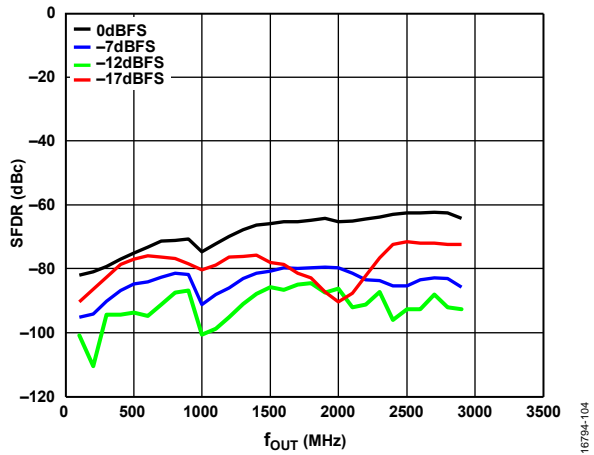

Figure 4. Third Harmonic (SFDR) vs.  $f_{OUT}$  over Digital Scale (Mode 0), 6 GHz DAC Sample Rate, Channel Interpolation 2x, Main Interpolation 8x

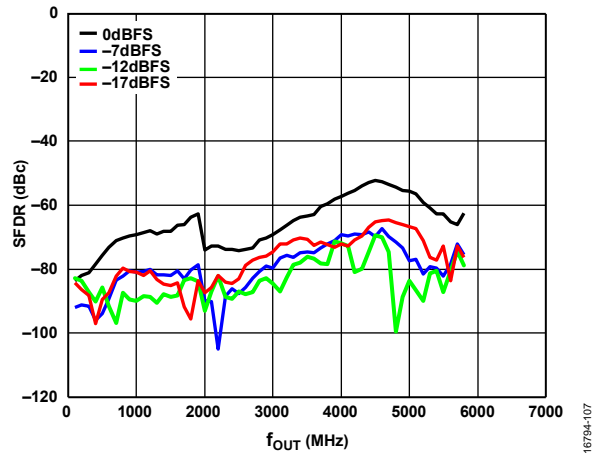

Figure 7. Third Harmonic (SFDR) vs.  $f_{OUT}$  over Digital Scale (Mode 1), 12 GHz DAC Sample Rate, Channel Interpolation 4x, Main Interpolation 8x

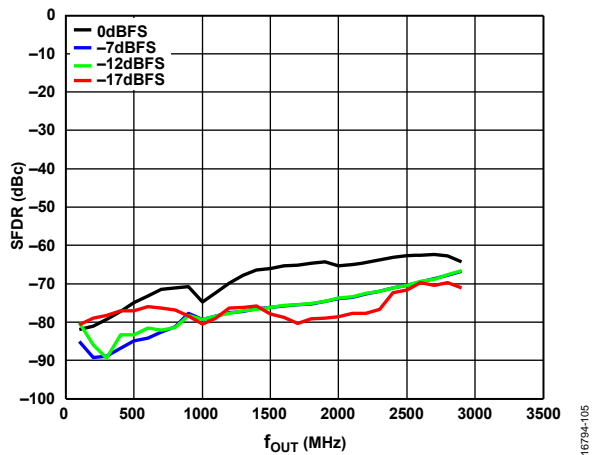

Figure 5. Worst Harmonic (SFDR) vs.  $f_{OUT}$  over Digital Scale (Mode 0), 6 GHz DAC Sample Rate, Channel Interpolation 2x, Main Interpolation 8x

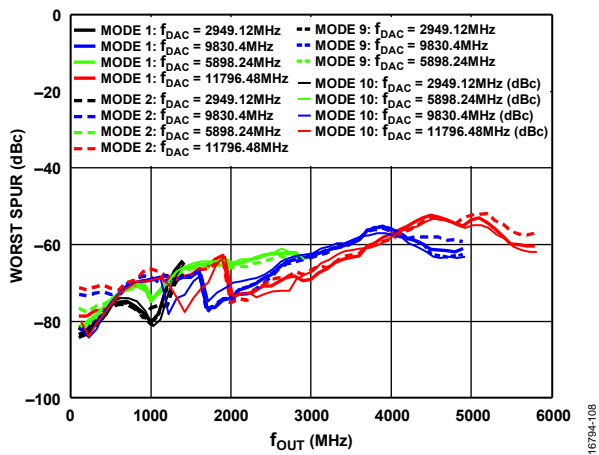

Figure 8. Worst Spur vs.  $f_{OUT}$  over  $f_{DAC}$  (All Modes), 0 dB Digital Scale

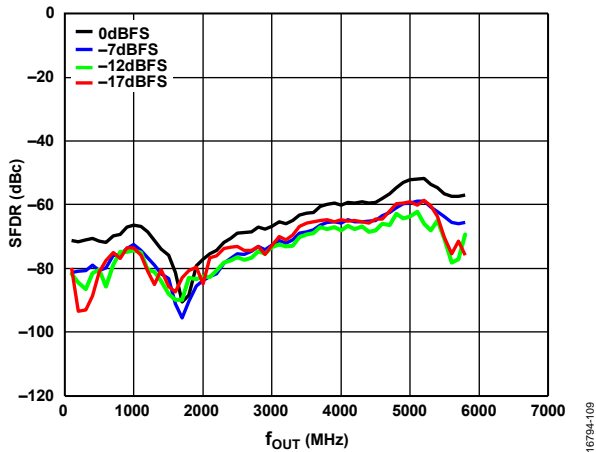

Figure 9. Second Harmonic (SFDR) vs.  $f_{OUT}$  over Digital Scale (Mode 2), 12 GHz DAC Sample Rate, Channel Interpolation 4x, Main Interpolation 8x

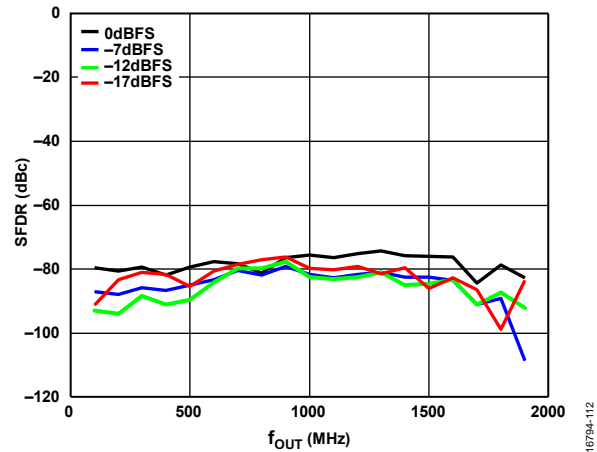

Figure 12. Second Harmonic (SFDR) vs.  $f_{OUT}$  over Digital Scale (Mode 12), 4 GHz DAC Sample Rate, Channel Interpolation 1x, Main Interpolation 1x, 12-Bit Resolution

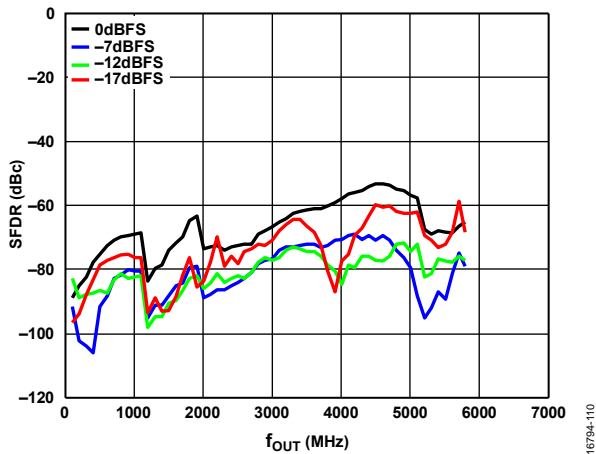

Figure 10. Third Harmonic (SFDR) vs.  $f_{OUT}$  over Digital Scale (Mode 2), 12 GHz DAC Sample Rate, Channel Interpolation 4x, Main Interpolation 8x

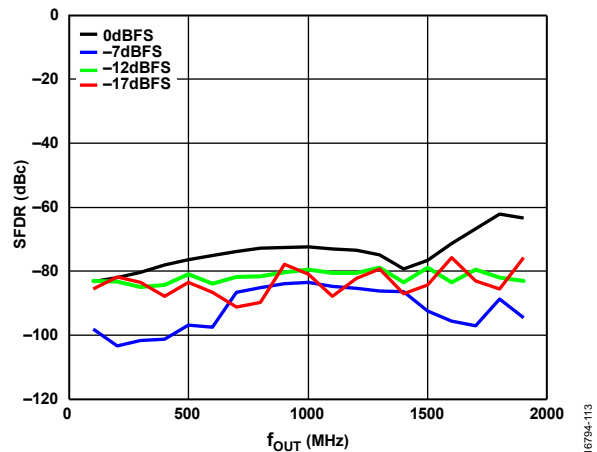

Figure 13. Third Harmonic (SFDR) vs.  $f_{OUT}$  over Digital Scale (Mode 12), 4 GHz DAC Sample Rate, Channel Interpolation 1x, Main Interpolation 1x, 12-Bit Resolution

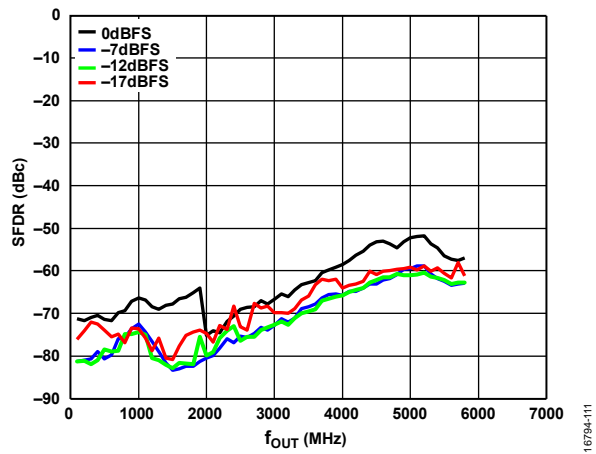

Figure 11. Worst Harmonic (SFDR) vs.  $f_{OUT}$  over Digital Scale (Mode 2), 12 GHz DAC Sample Rate, Channel Interpolation 4x, Main Interpolation 8x

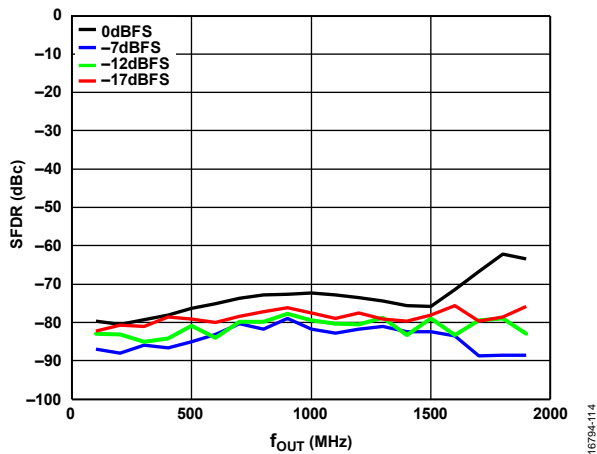
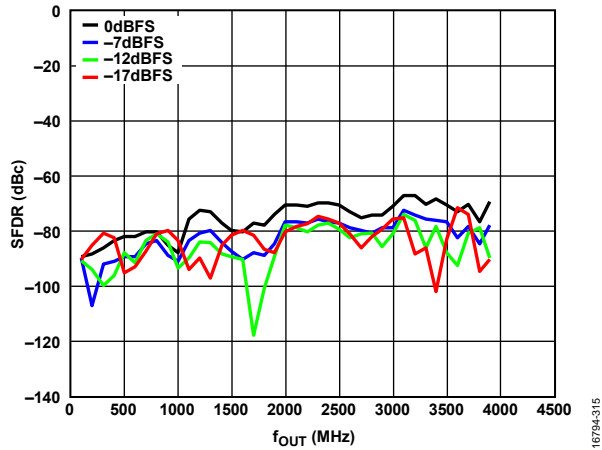
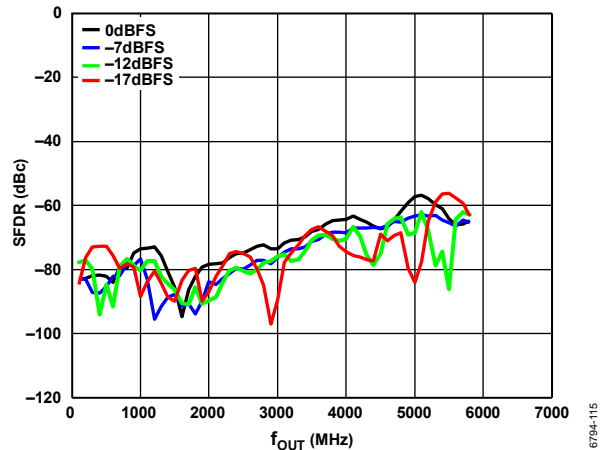

Figure 14. Worst Harmonic (SFDR) vs.  $f_{OUT}$  over Digital Scale (Mode 12), 4 GHz DAC Sample Rate, Channel Interpolation 1x, Main Interpolation 1x, 12-Bit Resolution



16794-315

Figure 15. Second Harmonic (SFDR) vs.  $f_{OUT}$  over Digital Scale (Mode 12), 8 GHz DAC Sample Rate, Channel Interpolation 1 $\times$ , Main Interpolation 2 $\times$ , 12-Bit Resolution



16794-115

Figure 18. Second Harmonic (SFDR) vs.  $f_{OUT}$  over Digital Scale (Mode 9), 12 GHz DAC Sample Rate, Channel Interpolation 1 $\times$ , Main Interpolation 8 $\times$

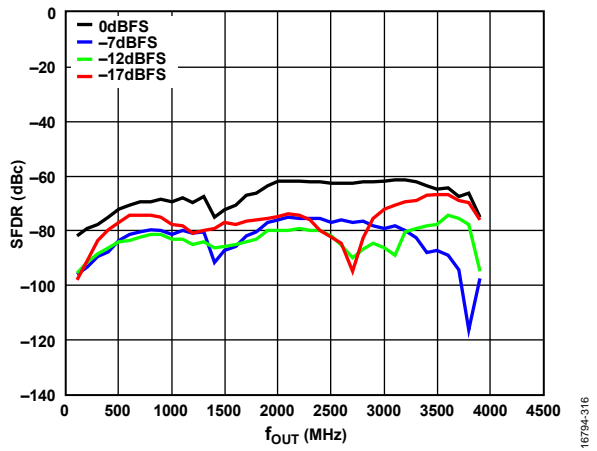

16794-316

Figure 16. Third Harmonic (SFDR) vs.  $f_{OUT}$  over Digital Scale (Mode 12), 8 GHz DAC Sample Rate, Channel Interpolation 1 $\times$ , Main Interpolation 2 $\times$ , 12-Bit Resolution

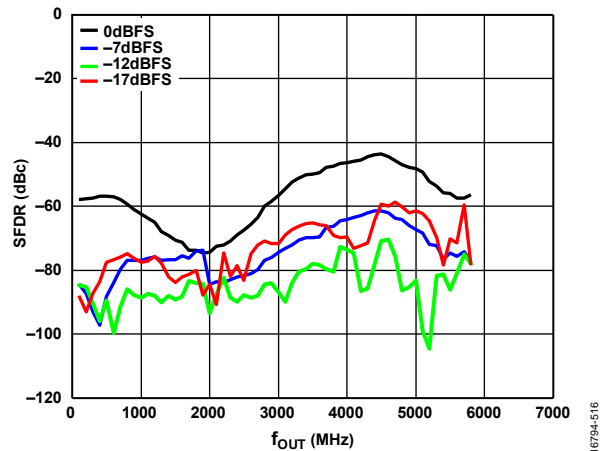

16794-516

Figure 19. Third Harmonic (SFDR) vs.  $f_{OUT}$  over Digital Scale (Mode 9), 12 GHz DAC Sample Rate, Channel Interpolation 1 $\times$ , Main Interpolation 8 $\times$

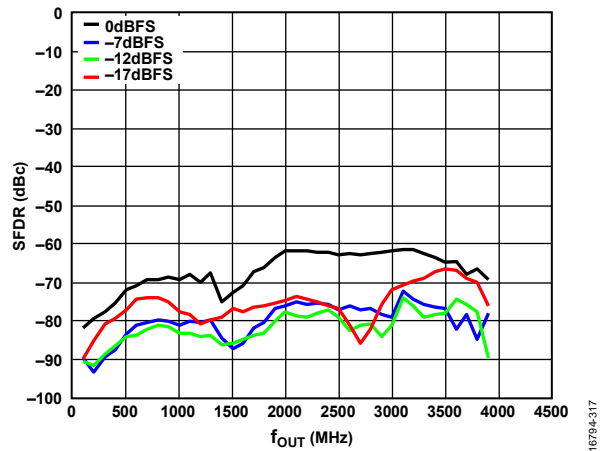

16794-317

Figure 17. Worst Harmonic (SFDR) vs.  $f_{OUT}$  over Digital Scale (Mode 12), 8 GHz DAC Sample Rate, Channel Interpolation 1 $\times$ , Main Interpolation 2 $\times$ , 12-Bit Resolution

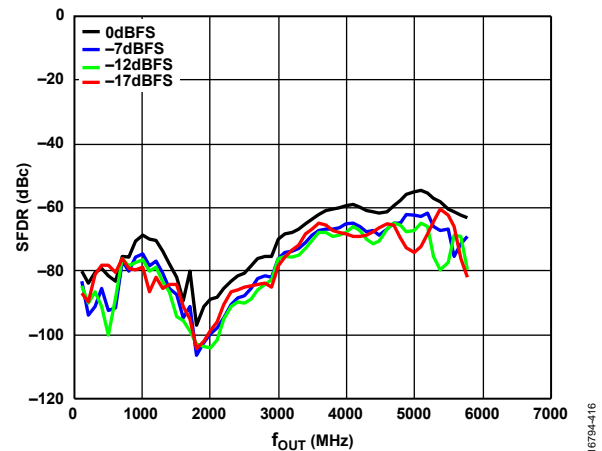

16794-416

Figure 20. Second Harmonic (SFDR) vs.  $f_{OUT}$  over Digital Scale (Mode 10), 12 GHz DAC Sample Rate, Channel Interpolation 1 $\times$ , Main Interpolation 4 $\times$

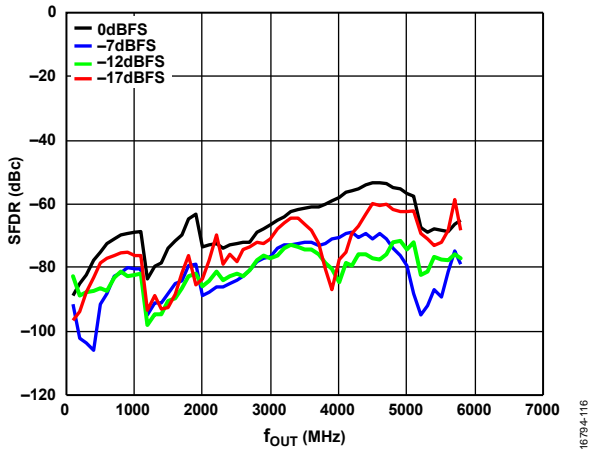

Figure 21. Third Harmonic (SFDR) vs.  $f_{OUT}$  over Digital Scale (Mode 10), 12 GHz DAC Sample Rate, Channel Interpolation 1x, Main Interpolation 4x

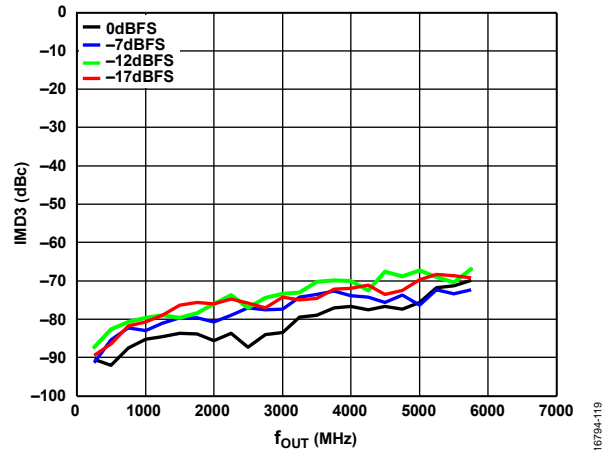

Figure 24. IMD3 vs.  $f_{OUT}$  over Digital Scale (Mode 1), 12 GHz DAC Sample Rate, Channel Interpolation 4x, Main Interpolation 8x, 1 MHz Tone Spacing

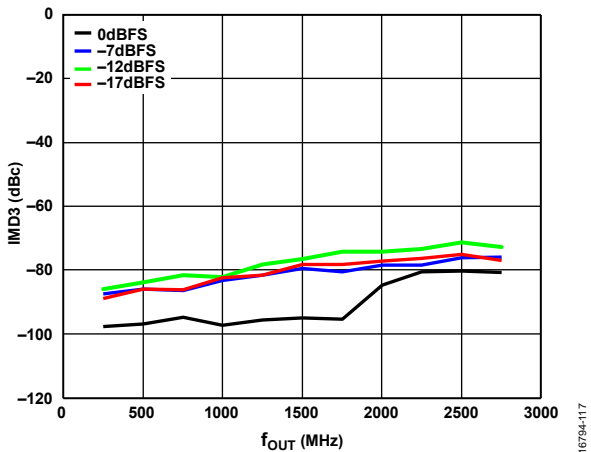

Figure 22. IMD3 vs.  $f_{OUT}$  over Digital Scale (Mode 0) 6 GHz DAC Sample Rate, Channel Interpolation 2x, Main Interpolation 8x, 1 MHz Tone Spacing

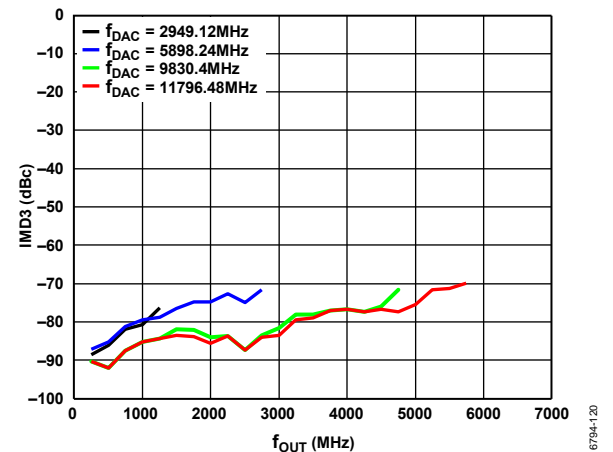

Figure 25. IMD3 vs.  $f_{OUT}$  over  $f_{DAC}$  (Mode 1), Channel Interpolation 4x, Main Interpolation 8x, 1 MHz Tone Spacing, -7 dB Digital Scale

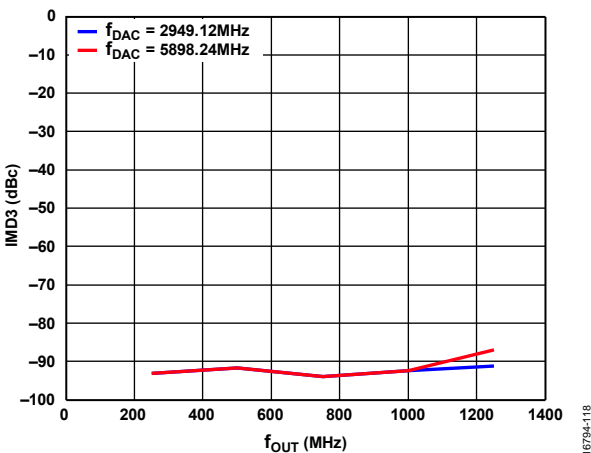

Figure 23. IMD3 vs.  $f_{OUT}$  over  $f_{DAC}$  (Mode 0), Channel Interpolation 2x, Main Interpolation 8x, 1 MHz Tone Spacing

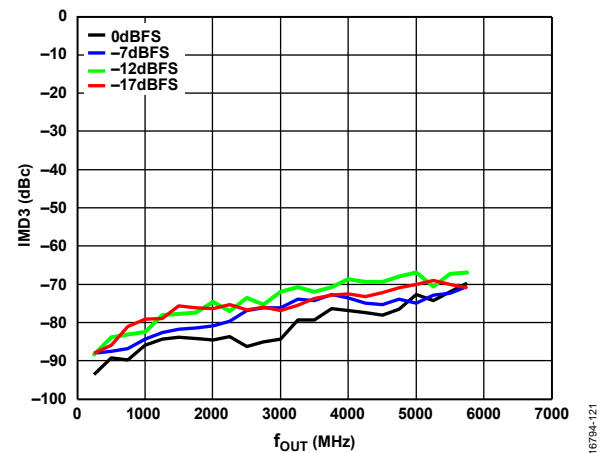

Figure 26. IMD3 vs.  $f_{OUT}$  over Digital Scale (Mode 2), 12 GHz DAC Sample Rate, Channel Interpolation 4x, Main Interpolation 8x, 1 MHz Tone Spacing

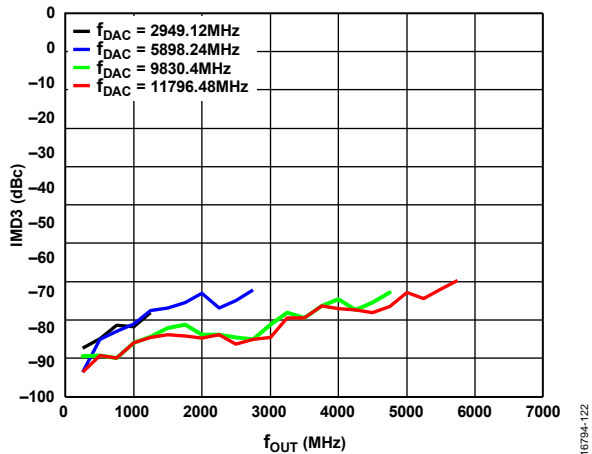

Figure 27. IMD3 vs.  $f_{OUT}$  over  $f_{DAC}$  (Mode 2), Channel Interpolation 4 $\times$ , Main Interpolation 8 $\times$ , 1 MHz Tone Spacing

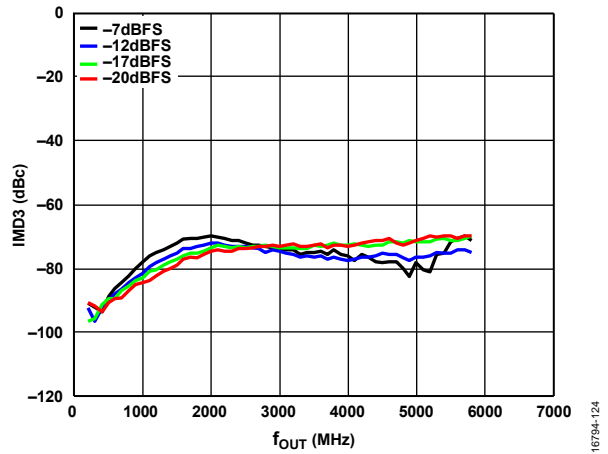

Figure 30. IMD3 vs.  $f_{OUT}$  over Digital Scale (Mode 10), 12 GHz DAC Sample Rate, Channel Interpolation 1 $\times$ , Main Interpolation 4 $\times$ , 1 MHz Tone Spacing

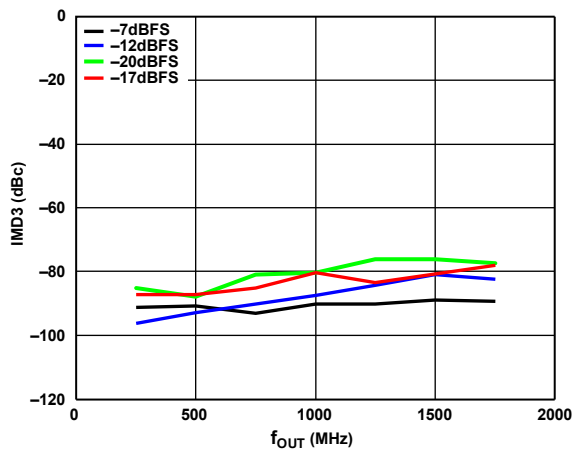

Figure 28. IMD3 vs.  $f_{OUT}$  over Digital Scale (Mode 12), 4 GHz DAC Sample Rate, Channel Interpolation 1 $\times$ , Main Interpolation 1 $\times$ , 1 MHz Tone Spacing, 12-Bit Resolution

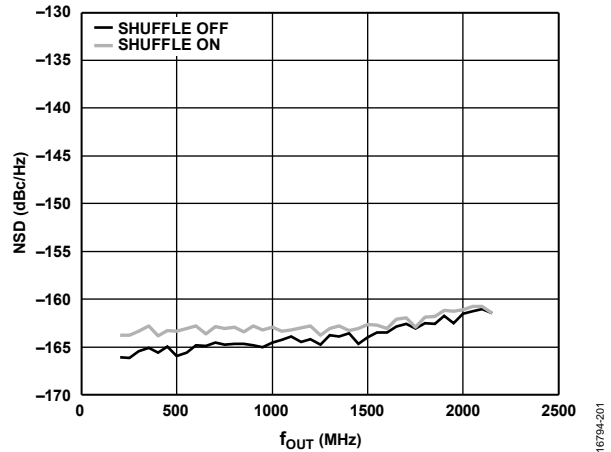

Figure 31. Single-Tone NSD Measured at 70 MHz vs.  $f_{OUT}$ , 11796.48 MHz  $f_{DAC}$ , 16-Bit Resolution, for Different Shuffle Options

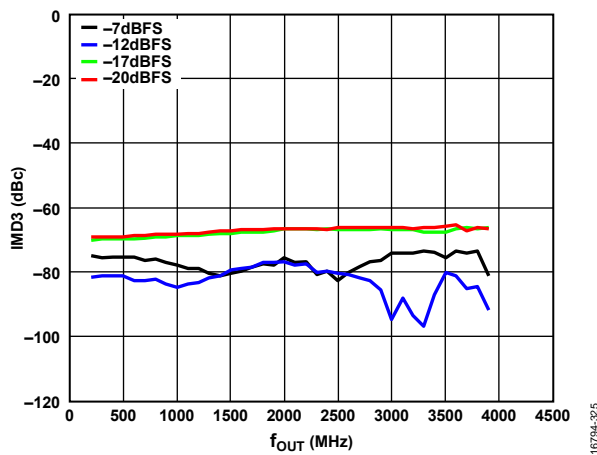

Figure 29. IMD3 vs.  $f_{OUT}$  over Digital Scale (Mode 12), 8 GHz DAC Sampling Rate, Channel Interpolation 1 $\times$ , Main Interpolation 2 $\times$ , 1 MHz Tone Spacing

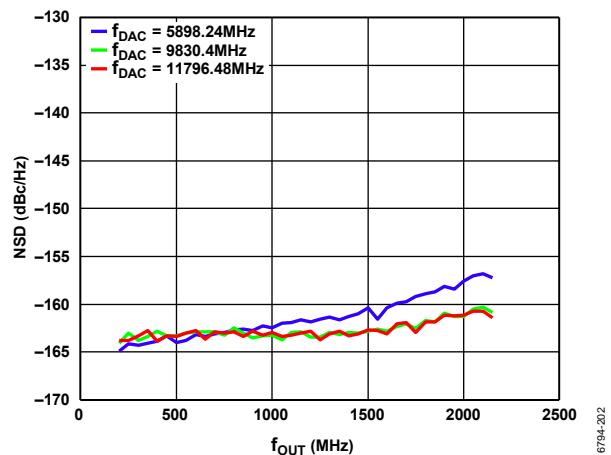

Figure 32. NSD vs.  $f_{OUT}$  over  $f_{DAC}$ , 16-Bit Resolution, Shuffle On, Single Tone Measured at 70 MHz

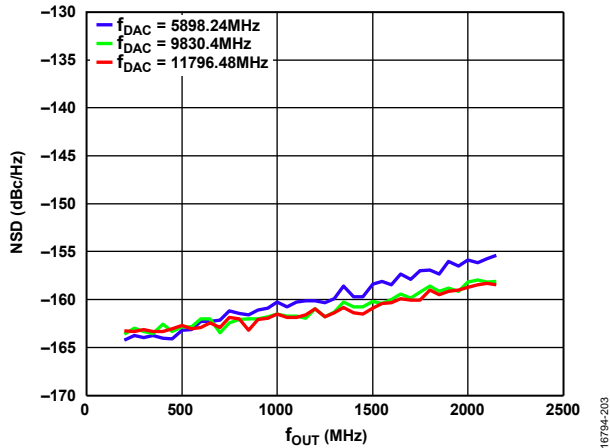

Figure 33. NSD vs.  $f_{OUT}$  over  $f_{DAC}$ , 16-Bit Resolution, Shuffle On, Single-Tone, Measured at 10% Offset from  $f_{OUT}$

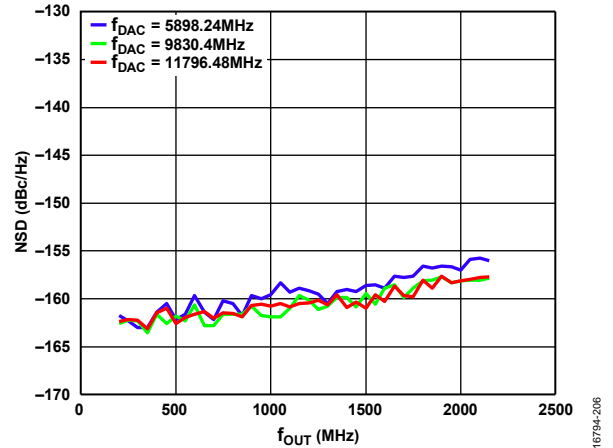

Figure 36. NSD vs.  $f_{OUT}$  over  $f_{DAC}$ , 12-Bit Resolution, Shuffle On, Single-Tone, Measured at 10% Offset from  $f_{OUT}$

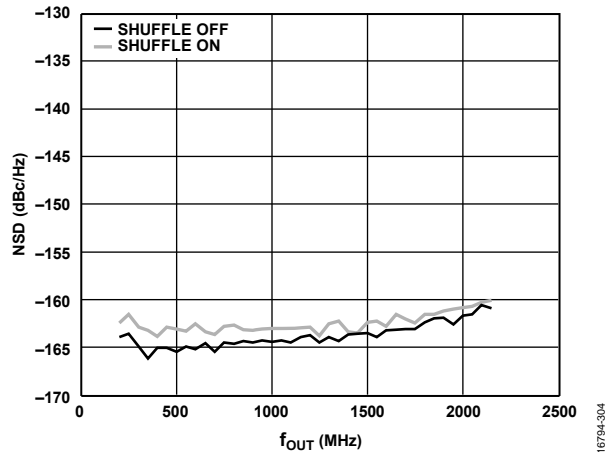

Figure 34. NSD vs.  $f_{OUT}$ , 11796.48 MHz  $f_{DAC}$ , 12-Bit Resolution, for Different Shuffle Options, Single-Tone, Measured at 70 MHz

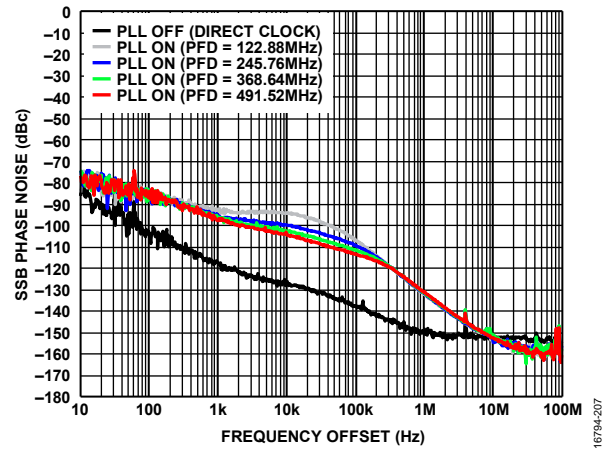

Figure 37. Single-Sideband (SSB) Phase Noise vs. Offset over  $f_{OUT}$ , over PFD Frequency,  $f_{DAC} = 12$  GHz,  $f_{OUT} = 1.8$  GHz, PLL On, PLL Reference Clock = 500 MHz

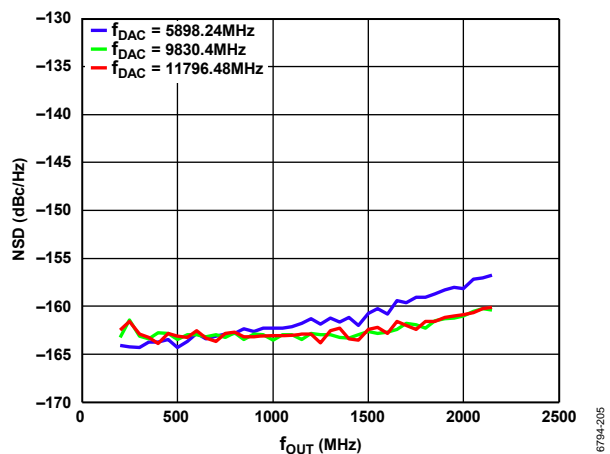

Figure 35. NSD vs.  $f_{OUT}$  over  $f_{DAC}$ , 12-Bit Resolution, Shuffle On, Single-Tone, Measured at 70 MHz

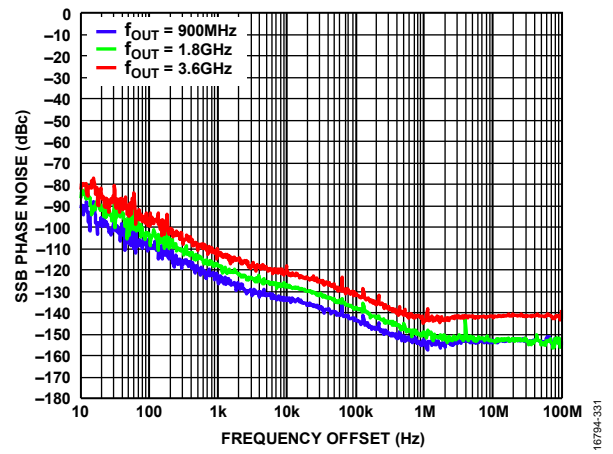

Figure 38. SSB Phase Noise vs. Frequency Offset over  $f_{OUT}$ ,  $f_{DAC} = 12$  GHz, Direct Clock (PLL Off)

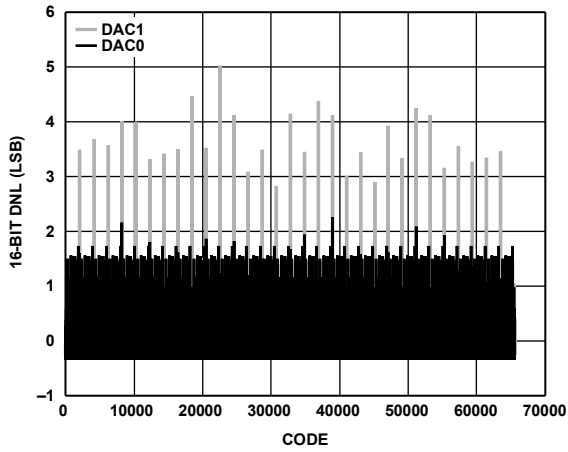

Figure 39. DNL,  $I_{OUTFS} = 26 \text{ mA}$ , 16-Bit Resolution

16794-208

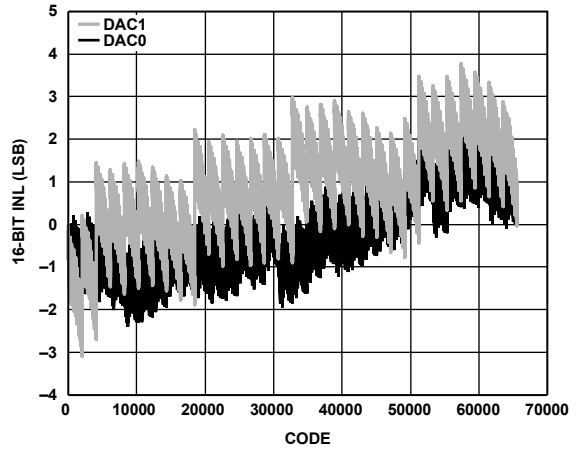

Figure 42. INL,  $I_{OUTFS} = 20 \text{ mA}$ , 16-Bit Resolution

16794-211

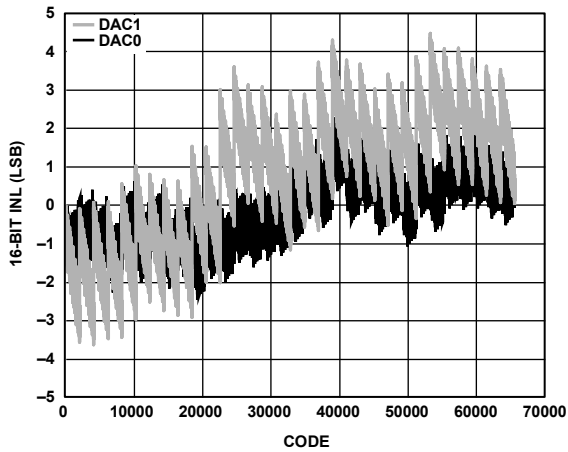

Figure 40. INL,  $I_{OUTFS} = 26 \text{ mA}$ , 16-Bit Resolution

16794-209

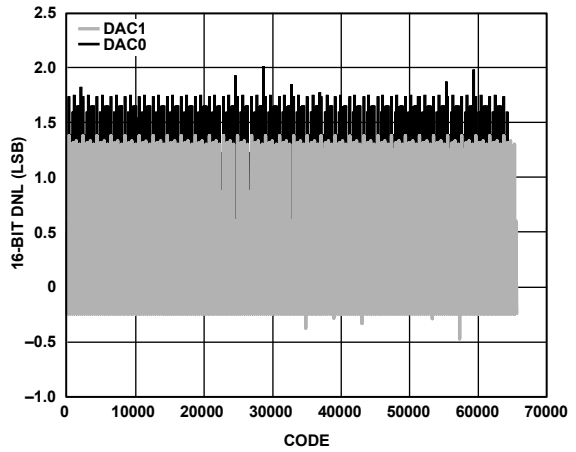

Figure 43. DNL,  $I_{OUTFS} = 15.6 \text{ mA}$ , 16-Bit Resolution

16794-212

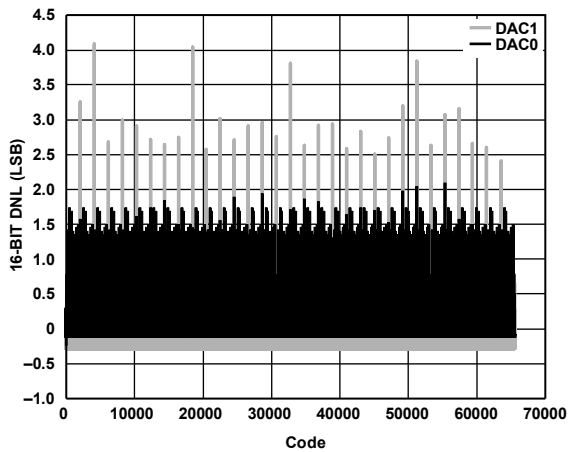

Figure 41. DNL,  $I_{OUTFS} = 20 \text{ mA}$ , 16-Bit Resolution

16794-210

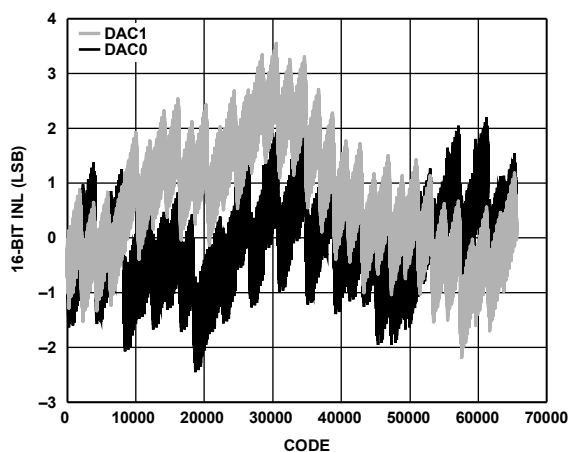

Figure 44. INL,  $I_{OUTFS} = 15.6 \text{ mA}$ , 16-Bit Resolution

16794-213

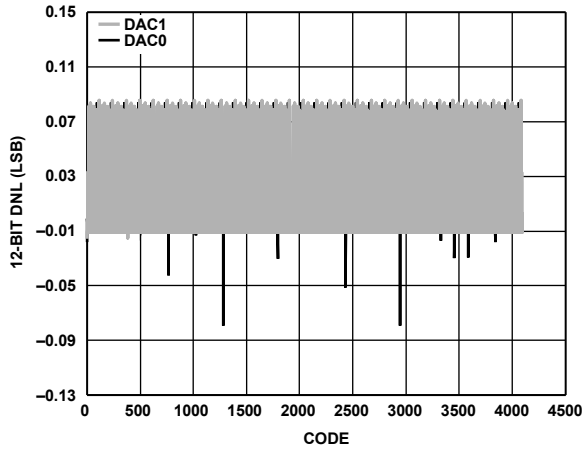

Figure 45. DNL,  $I_{OUTFS} = 20\text{ mA}$ , 12-Bit Resolution

16794-214

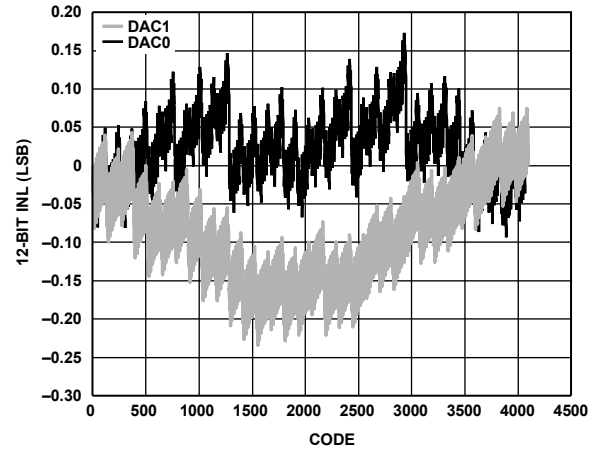

Figure 46. INL,  $I_{OUTFS} = 20\text{ mA}$ , 12-Bit Resolution

16794-215

## TERMINOLOGY

### Integral Nonlinearity (INL)

INL is the maximum deviation of the actual analog output from the ideal output, determined by a straight line drawn from zero scale to full scale.

### Differential Nonlinearity (DNL)

DNL is the measure of the variation in analog value, normalized to full scale, associated with a 1 LSB change in digital input code.

### Offset Error

Offset error is the deviation of the output current from the ideal value of 0 mA. For DACx+, a 0 mA output is expected when all inputs are set to 0. For DACx-, a 0 mA output is expected when all inputs are set to 1.

### Gain Error

Gain error is the difference between the actual and ideal output span. The actual span is determined by the difference between the output when the input is at its minimum code and the output when the input is at its maximum code.

### Output Compliance Range

The output compliance range is the range of allowable voltages at the output of a current output DAC. Operation beyond the maximum compliance limits can cause either output stage saturation or breakdown, resulting in nonlinear performance.

### Temperature Drift

Temperature drift is specified as the maximum change from the ambient (25°C) value to the value at either  $T_{MIN}$  or  $T_{MAX}$ . For offset and gain drift, the drift is reported in ppm of full-scale range (FSR) per degree Celsius. For reference drift, the drift is reported in ppm per degree Celsius.

### Settling Time

Settling time is the time required for the output to reach and remain within a specified error band around its final value, measured from the start of the output transition.

### Spurious-Free Dynamic Range (SFDR)

SFDR is the difference, in decibels, between the peak amplitude of the output signal and the peak spurious signal within the dc to Nyquist frequency of the DAC. Typically, energy in this band is rejected by the interpolation filters. This specification, therefore, defines how well the interpolation filters work and the effect of other parasitic coupling paths on the DAC output.

### Signal-to-Noise Ratio (SNR)

SNR is the ratio of the rms value of the measured output signal to the rms sum of all other spectral components below the Nyquist frequency, excluding the first six harmonics and dc. The value for SNR is expressed in decibels.

### Interpolation Filter

If the digital inputs to the DAC are sampled at a multiple rate of the interpolation rate ( $f_{DATA}$ ), a digital filter can be constructed that has a sharp transition band near  $f_{DATA}/2$ . Images that typically appear around the output data rate ( $f_{DAC}$ ) can be greatly suppressed.

### Channel Datapath

The channel datapath, sometimes referred to as a channelizer, is a complex (IQ) datapath. There are six channelizers within the chip, with three channelizers summed in each main datapath. The channelizers can be bypassed if unused, depending on the mode of operation. When the channelizers are in use, a complex (I/Q) input data stream is required. Each channel datapath includes an independently controlled gain stage and a channel NCO. A selectable channel interpolation block is configurable according to the mode of operation. All channels must be set to the same interpolation rate.

### Main Datapath

The main datapath refers to the portion of the digital datapath after the summing node in the chip, up to each of the main DAC analog cores. Each of these main datapaths includes an optional PA protection block with a feed forward to the ramp up/down gain stage block for muting the DAC outputs before damaging a power amplifier in the transmit path. There is a selectable main interpolation block that is configurable (same setting for both main interpolation blocks) depending on the mode of operation chosen. Each main datapath also contains an individually programmable main NCO per main DAC datapath that can be optionally used depending on the mode of operation.

### Adjacent Channel Leakage Ratio (ACLR)

ACLR is the ratio in decibels relative to the carrier (dBc) between the measured power within a channel relative to its adjacent channel.

### Adjusted DAC Update Rate

The adjusted DAC update rate is the DAC update rate divided by the smallest interpolating factor. For clarity on DACs with multiple interpolating factors, the adjusted DAC update rate for each interpolating factor may be given.

### Physical (PHY) Lane

Physical Lane x refers to  $SERDIN_{x\pm}$ .

### Logical Lane

Logical Lane x refers to physical lanes after optionally being remapped by the crossbar block (Register 0x308 to Register 0x30B).

### Link Lane

Link Lane x refers to logical lanes considered per link. When paging Link 0 (Register 0x300[2] = 0), Link Lane x = Logical Lane x. When paging Link 1 (Register 0x300[2] = 1, dual link only), Link Lane x = Logical Lane x + 4.

## THEORY OF OPERATION

The AD9174 is a 16-bit, dual RF DAC with a high speed JESD204B SERDES interface, compliant with Subclass 0 and Subclass 1 operation. Figure 1 shows a functional block diagram of the AD9174. Each DAC core has three individually bypassable channels that support up to 1.575 GSPS of complex data rate input per channel. The JESD204B interface can be configured for either single-link or a dual-link operation, in which each of the eight high speed serial ports can carry data at a maximum of 15.4 Gbps to the channel datapaths, referred to as channelizers. Compared to either LVDS or CMOS interfaces, the SERDES interface simplifies pin count, board layout, and input clock requirements to the device.

The local clock for the SERDES interface is derived from the device clock (CLKIN± pins) as required by the JESD204B specification. The device clock either acts as a reference for the on-chip PLL to provide a DAC clock, or the PLL can be bypassed and the DAC clock can be provided directly from a high fidelity, external clock source. The SERDES interface can be configured to operate in one, two, three, four, or eight lane per link modes, depending on the required input data rate. In dual-link operation, each link can occupy a maximum of four lanes each.

The digital datapath of the AD9174 includes bypassable (1×) interpolation blocks in both the channel datapaths and the main datapaths. Depending on the desired mode, there are also 2×, 3×, 4×, 6×, and 8× interpolation options for the channel datapaths, and 2×, 4×, 6×, 8×, and 12× interpolation options for the main datapaths. See Table 13 for a summary of the various supported processing modes, as well as the associated interpolation options.

Unless 1× interpolation (bypass) is selected, each channel digital datapath allows the user to individually control the gain stages and NCO blocks at each channel. The NCO blocks have a 48-bit modulus NCO option to enable digital frequency shifts of signals with near infinite precision. At the end of the three channelizer datapaths, there is a summation node that combines the three channelizers together at a maximum of 1.575 GSPS, sent as an input to the respective main DAC datapaths for further digital processing.

Each main DAC datapath contains an optional power amplifier (PA) protection block, a main datapath interpolation block, a main NCO with an optional modulus feature, and a ramp-up/ramp-down gain block that is fed by the PA protection block. Additionally, there is an optional calibration tone feature, as well as four modulator switch modes that are part of the main NCO block.

Each NCO can operate as a standalone NCO in direct digital synthesis (DDS) mode. The level of the NCO tone can be either individually assigned by providing digital data from the SERDES interface, or collectively assigned to all NCOs using a SPI-programmable register. The frequency can be individually controlled.

The AD9174 is also capable of FFH, which allows quick hopping between 31 additional NCOs, each operating at a 32-bit precision. Various modes of operation exist where either coherence or phase continuity can be maintained between hops. Only a single SPI write is required to hop to the next frequency, assuming each frequency tuning word (FTW) is preloaded.

The AD9174 is also capable of multichip synchronization that can both synchronize multiple DACs and establish a constant and deterministic latency (latency locking) path for the DACs. The latency for each DAC remains constant to within several DAC clock cycles from link establishment to link establishment. An external alignment signal (SYSREF±) makes the AD9174 JESD204B Subclass 1 compliant. Several methods of SYSREF± signal handling are available for use in the system.

An SPI port configures the various functional blocks and monitors their status. The various functional blocks and the data interface must be set up in a predetermined sequence for proper operation (see the Start-Up Sequence section). Simple SPI initialization routines set up the JESD204B link and are included in the [AD9174-FMC-EBZ](#) evaluation board package. This data sheet describes the various blocks of the AD9174 in detail. Descriptions of the JESD204B interface, control parameters, and various registers to set up and monitor the device are provided. The recommended start-up routine reliably sets up the data link.

Table 13. JESD204B Supported Operating Modes and Interpolation Combinations

Application	JESD204B Operation Modes			Channel Datapath			Main DAC Datapath		Maximum Instantaneous Bandwidth (MHz) <sup>3</sup>
	Link Modes	JESD204B Modes	Lanes per Link	Channels per DAC	Maximum Channel Data Rate (MSPS) <sup>1</sup>	Channel Interpolation	Main Datapath Interpolation	Maximum DAC Rate (GSPS) <sup>2</sup>	
Channelizer Modes (All Complex)									
375 MHz (N = 16 Bits)									
Single-Channel	Single, dual	0	1	1	385	2x	8x	6.16	308
		0	1	1	385	4x, 6x	6x, 8x	12.6	308
Dual-Channel	Single, dual	1	2	2	385	4x, 6x	6x, 8x	12.6	616
Triple-Channel	Single, dual	2	3	3	385	4x, 6x	6x, 8x	12.6	924
500 MHz (N = 12 Bits)									
Single-Channel	Single, dual	5	1	1	513	2x	6x	6.16	410.4
		5	1	1	513	3x	6x, 8x	12.6	410.4
Dual-Channel	Single, dual	6	2	2	513	3x	6x, 8x	12.6	
750 MHz (N = 16 Bits)									
Single-Channel	Single, dual	3	2	1	770	1x	8x	6.16	616
		3	2	1	770	2x, 3x	6x, 8x	12.6	616
Dual-Channel	Single, dual	4	4	2	770	2x, 3x	6x, 8x	12.6	616
		4	4	2	385	4x	8x	12.6	308
187 MHz (N = 16 Bits)									
Dual-Channel	Single, dual	7	1	2	192.5	8x	6x, 8x	12.6	154
Wideband Modes (Complex or Real)									
3000 MHz (N = 16 Bits)									
Complex	Single	10, 11	8	1	3080	1x	2x, 4x	12.6	2464
Real, Dual-DAC	Single	10, 11	8	1	3080	1x	1x	3.08	1540
Real, Single- or Dual-DAC	Single, dual	18, 19	4	1	3080	1x	1x	3.08	1540
1500 MHz (N = 16 Bits)									
Complex, Dual-DAC	Single, dual	8, 9	4	2 <sup>4</sup>	1540	1x	2x, 4x, 6x, 8x, 12x	12.6	2464 <sup>4</sup>
4000 MHz (N = 12 Bits)									
Complex	Single	12	8	1	4100	1x	2x <sup>5</sup>	8.2	3280
Real, Dual-DAC	Single	12	8	1	4100	1x	1x	4.1	2050
2000 MHz (N = 12 Bits)									
Complex, Dual-DAC	Single, dual	22	4	2 <sup>4</sup>	2050	1x	4x, 6x	12.6	3280 <sup>4</sup>
6000 MHz (N = 16 Bits)									
Real, Single-DAC	Single	20, 21	8	1	6160	1x	1x	6.16	3080

<sup>1</sup> The maximum data rate is calculated based on a maximum lane rate as listed in Table 7. The data rate is calculated based on the formula lane rate = (10/8) × NP × data rate × (M/L), where the NP, M, and L values depend on the selected mode.

<sup>2</sup> The maximum DAC rate per mode depends on the voltage tolerance as well as the lane rate for a given configuration, as listed in Table 3. The maximum possible lane rate is according to Table 7.

<sup>3</sup> For complex modes, instantaneous bandwidth (IBW) is the bandwidth that both I and Q occupy (referred to as the combined I/Q bandwidth). The bandwidth for complex modes is in part limited by the bandwidth of the interpolation filters. When the interpolation filters are bypassed to configure the AD9174 in real only mode, IBW = ½ × data rate.

<sup>4</sup> With a correct modulator switch configuration, the AD9174 can be configured to operate as a wideband, dual-channel DAC, with each channel to include its own main datapath NCO. In this case, the modulator switch is configured to act as a summing node that feeds complex data from two datapaths to a single DAC core.

<sup>5</sup> Only supported when JESD204B is configured for Subclass 1 operation.

## SERIAL PORT OPERATION

The serial port is a flexible, synchronous serial communications port that allows easy interfacing with many industry-standard microcontrollers and microprocessors. The serial input/output is compatible with most synchronous transfer formats, including both the Motorola, Inc., SPI and Intel® SSR protocols. The interface allows read and write access to all registers that configure the AD9174. MSB first or LSB first transfer formats are supported. The serial port interface can be configured as a 4-wire interface or a 3-wire interface in which the input and output share a single pin input/output (SDIO). Data can be transferred either one byte at a time, with the address specified for each read/write operation, or can be transferred in multibyte mode, with the address incremented automatically at the end of each transfer cycle, thus increasing link throughput when multiple read/write operations to register addresses are sequential.

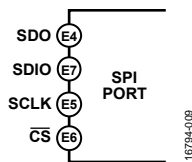

Figure 47. Serial Port Interface Pins (144-Ball BGA\_ED)

There are two phases to a communication cycle with the AD9174. Phase 1 is the instruction cycle (the writing of an instruction byte into the device), coincident with the first 16 SCLK rising edges. The instruction word provides the serial port controller with information needed for Phase 2 of the communication cycle, namely the data transfer cycle. The instruction word defines the starting register address for the following data transfer and flags, whether the upcoming data transfer is a read operation or a write operation.

A logic high on the  $\overline{CS}$  pin followed by a logic low resets the serial port timing to the initial state of the instruction cycle. From this state, the next 16 rising SCLK edges represent the instruction bits of the current input/output operation.

The remaining SCLK edges are for Phase 2 of the communication cycle. Phase 2 is the actual data transfer between the device and the system controller. Phase 2 of the communication cycle is a transfer of one or more data bytes. Eight  $\times$  N SCLK cycles are required to transfer N bytes during the transfer cycle. The registers update (latch) their data immediately upon writing to the last bit of each transfer byte.

The FTW and NCO phase offsets change only when the frequency tuning word load request bit (DDSM\_FT\_W\_LOAD\_REQ or DDSC\_FT\_W\_LOAD\_REQ) is set.

## DATA FORMAT

The instruction byte contains the information shown in Table 14.

Table 14. Serial Port Instruction Word

I15 (MSB)	I[14:0]
R/W	A[14:0]

$\overline{R/W}$ , Bit 15 of the instruction word, determines whether a read or a write data transfer occurs after the instruction word write. Logic 1 indicates a read operation, and Logic 0 indicates a write operation.

A14 to A0, Bit I14 to Bit I0 of the instruction word, determine the register that is accessed during the data transfer portion of the communication cycle.

For multibyte transfers, A[14:0] is the starting address. The remaining register addresses are generated by the device based on the address increment bit. If the address increment bits are set high (Register 0x000, Bit 5 and Bit 2), multibyte SPI writes start on A[14:0] and increment by 1 every eight bits sent/received. If the address increment bits are set to 0, the address decrements by 1 every eight bits.

## SERIAL PORT PIN DESCRIPTIONS

### Serial Clock (SCLK)

The serial clock pin synchronizes data to and from the device and runs the internal state machines. The maximum frequency of SCLK is 80 MHz. All data input is registered on the rising edge of SCLK. All data is driven out on the falling edge of SCLK.

### Chip Select ( $\overline{CS}$ )

An active low input starts and gates a communication cycle.  $\overline{CS}$  allows more than one device to be used on the same serial communications lines. The SDIO pin goes to a high impedance state when this input is high. During the communication cycle, the chip select must stay low.

### Serial Data Input/Output (SDIO)

This pin is a bidirectional data line. In 4-wire mode, this pin acts as the data input and SDO acts as the data output.

**SERIAL PORT OPTIONS**

The serial port can support both MSB first and LSB first data formats. This functionality is controlled by the LSB first bit (Register 0x000, Bit 6 and Bit 1). The default is MSB first (LSBFIRST bit = 0).

When the LSB first bits = 0 (MSB first), the instruction and data bits must be written from MSB to LSB.  $R/\overline{W}$  is followed by A[14:0] as the instruction word, and D[7:0] is the data-word. When the LSB first bits = 1 (LSB first), the opposite is true. A[0:14] is followed by  $R/\overline{W}$ , which is subsequently followed by D[0:7].

The serial port supports a 3-wire or 4-wire interface. When the SDO active bits = 1 (Register 0x000, Bit 4 and Bit 3), a 4-wire interface with a separate input pin (SDIO) and output pin (SDO) is used. When the SDO active bits = 0, the SDO pin is unused and the SDIO pin is used for both the input and the output.

Multibyte data transfers can be performed as well by holding the  $\overline{CS}$  pin low for multiple data transfer cycles (eight SCLKs) after the first data transfer word following the instruction cycle. The first eight SCLKs following the instruction cycle read from or write to the register provided in the instruction cycle. For each additional eight SCLK cycles, the address is either incremented or decremented and the read/write occurs on the new register. The direction of the address can be set using ADDRINC or ADDRINC\_M (Register 0x000, Bit 5 and Bit 2). When ADDRINC or ADDRINC\_M is 1, the multicycle addresses are incremented. When ADDRINC or ADDRINC\_M is 0, the addresses are decremented. A new write cycle can always be initiated by bringing  $\overline{CS}$  high and then low again.

To prevent confusion and to ensure consistency between devices, the chip tests the first nibble following the address phase, ignoring the second nibble. This test is completed independently from the LSB first bits and ensures that there are extra clock cycles following the soft reset bits (Register 0x000, Bit 0 and Bit 7). This test of the first nibble only applies when writing to Register 0x000.

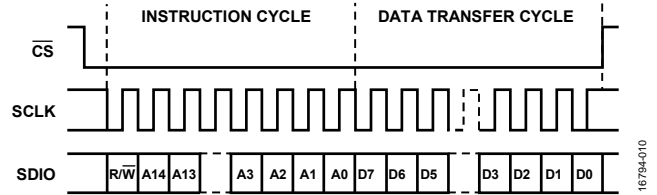

Figure 48. Serial Register Interface Timing, MSB First, Register 0x000, Bit 6 and Bit 1 = 0

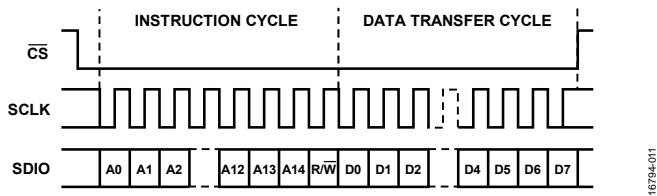

Figure 49. Serial Register Interface Timing, LSB First, Register 0x000, Bit 6 and Bit 1 = 1

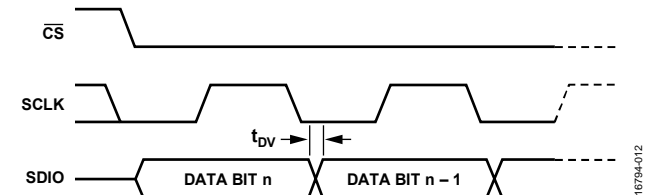

Figure 50. Timing Diagram for Serial Port Register Read

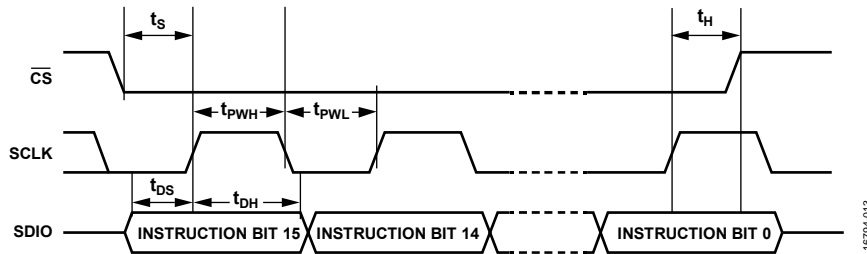

Figure 51. Timing Diagram for Serial Port Register Write

## JESD204B SERIAL DATA INTERFACE

### JESD204B OVERVIEW

The AD9174 has eight JESD204B SERDES data ports that receive the input sample data to the device. The eight JESD204B ports can be combined to form either one (single-link) or two (dual-link) identical JESD204B links. Each link can provide data to its own datapath with its own set of channelizers.

Both single- and dual-link JESD204B modes align their individual (local) clocks to the same system reference ( $\overline{\text{SYSREF}}_{\pm}$ ) and device clock ( $\overline{\text{CLKIN}}_{\pm}$ ) signals. However, the  $\overline{\text{SYNCOUT0}}_{\pm}$  and  $\overline{\text{SYNCOUT1}}_{\pm}$  signals are specific to their respective JESD204B link, and in dual-link mode the two links can operate independently from one another.

The JESD204B serial interface hardware is grouped into three layers: the physical layer, the data link layer, and the transport layer. Figure 52 shows the three communication layers implemented in the AD9174 serial data interface to recover the clock and deserialize, descramble, and deframe the data before it is sent to each of the digital signal processing channelizers of the device.

The communication layers are described as follows:

- The physical layer establishes a reliable channel between the transmitter and the receiver.
- The data link layer is responsible for unpacking the data into octets and descrambling the data.
- The transport layer receives the descrambled JESD204B frames and converts them to DAC samples.

A detailed description of each layer is provided in the subsequent sections, including information for configuring each aspect of the interface.

A number of JESD204B parameters (L, F, K, M, N, NP, S, HD) defines how the data is packed and tells the device how to turn the serial data into samples. These parameters are described in detail in the Transport Layer section. The AD9174 also has a descrambling option (see the Descrambler section for more information). To increase the maximum data rate achievable by the SERDES interface, the AD9174 has the ability to use a 12-bit packing mode ( $NP = 12$ ,  $N = 11$  or  $12$ ) for applications that do not require 16-bit data.

The AD9174 has multiple JESD204B modes, which include single- and dual-link modes, and allow configuration of the device depending on the number channels, number of DAC cores, and link speed requirements. These modes and their respective JESD204B link parameters are described in Table 15 and Table 16. Various combinations of channel interpolation

and main datapath interpolation are available, depending on the mode. Table 13 lists all the possible link and interpolation combinations available as well as the maximum supported data rate for each mode.

The AD9174 has two DAC cores, each with its own analog output. Each DAC core is supplied with data from as many as three complex channelizers. The effective number of converters, as seen by the JESD204B link, is the number of noncomplex channels in the given mode of operation, as represented by the M parameter of the JESD204B standard. Therefore, a single noncomplex channel is represented by  $M = 1$ , a complex channel is represented by  $M = 2$ , a group of two complex channels is represented by  $M = 4$ , and so on. When the total datapath interpolation is set to  $1\times$ , the complex channels are bypassed and the data input is assumed to be noncomplex (real). In this case only,  $M = 2$  represents the actual number of DAC cores, and the complex data is not required.

For a particular JESD204B mode of operation, the following relationships exist:

$$\text{Total Interpolation} = \text{Channel Interpolation} \times \text{Main Interpolation}$$

$$\text{Data Rate} = \text{DAC Rate} / \text{Total Interpolation}$$

$$\text{Lane Rate} = (M/L) \times NP \times (10/8) \times \text{Data Rate}$$

where:

*Lane Rate* must be between 3 Gbps and 15.4 Gbps.

*M*, *L*, and *NP* are JESD204B link parameters for the chosen JESD204B operating mode.

Achieving and maintaining synchronous operation between the JESD204B transmitter and the JESD204B receiver is critical for maintaining a reliable link. After the link is established, the stability and phase relationship between the various system clocks becomes important. If a particular clock slips relative to a common reference, the link may be lost and may need to be reestablished. Similarly, if a particular lane becomes asynchronous relative to other lanes within the link, this link may be lost as well. To simplify the process of establishing or reestablishing a link, the AD9174 designates an independent master synchronization signal for each JESD204B link. The  $\overline{\text{SYNCOUT0}}_{\pm}$  and  $\overline{\text{SYNCOUT1}}_{\pm}$  pins are used as the master flag signal for all the lanes in the particular link. If the data arriving on the various lanes appears to be out of synchronization,  $\overline{\text{SYNCOUTx}}_{\pm}$  is deasserted and the transmitter is expected to stop sending data and instead begin sending synchronization characters to all the lanes in that link until resynchronization is achieved.

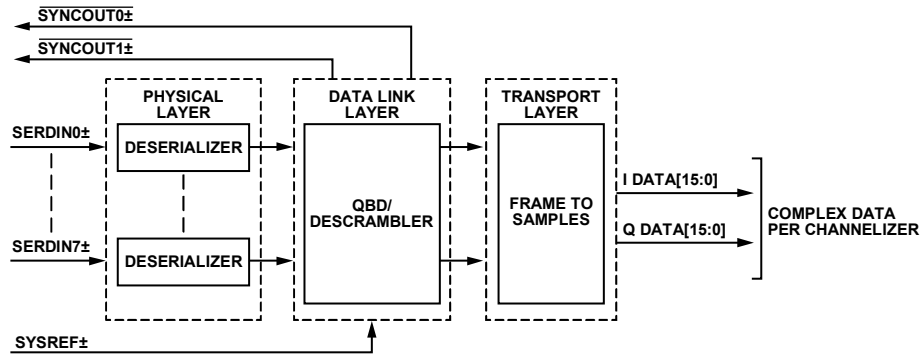

Figure 52. Functional Block Diagram of Serial Link Receiver

Table 15. Single-Link JESD204B Operating Modes

Parameter	Single-Link JESD204B Modes																	
	0	1	2	3	4	5	6	7	8	9	10	11	12	18	19	20	21	22
L (Lane Count)	1	2	3	2	4	1	2	1	4	4	8	8	8	4	4	8	8	4
M (Converter Count)	2	4	6	2	4	2	4	4	2	2	2	2	2	1	1	1	1	2
F (Octets per Frame per Lane)	4	4	4	2	2	3	3	8	1	2	1	2	3	1	2	1	2	3
S (Samples per Converter per Frame)	1	1	1	1	1	1	1	1	1	2	2	4	8	2	4	4	8	4
NP (Total Number of Bits per Sample)	16	16	16	16	16	12	12	16	16	16	16	16	12	16	16	16	16	12
N (Converter Resolution)	16	16	16	16	16	12	12	16	16	16	16	16	12	16	16	16	16	12
K (Frames per Multiframe)	32	32	32	32	32	32	32	32	32	32	32	32	32	32	32	32	32	32
HD (High Density User Data Format)	1	1	1	1	1	1	1	1	1	1	1	1	1	1	1	1	1	1

Table 16. Dual-Link JESD204B Operating Modes

Parameter	Dual-Link JESD204B Modes													
	0	1	2	3	4	5	6	7	8	9	18	19	22	
L (Lane Count)	1	2	3	2	4	1	2	1	4	4	4	4	4	
M (Converter Count)	2	4	6	2	4	2	4	4	2	2	1	1	2	
F (Octets per Frame per Lane)	4	4	4	2	2	3	3	8	1	2	1	2	3	
S (Samples per Converter per Frame)	1	1	1	1	1	1	1	1	1	2	2	4	4	
NP (Total Number of Bits per Sample)	16	16	16	16	16	12	12	16	16	16	16	16	12	
N (Converter Resolution)	16	16	16	16	16	12	12	16	16	16	16	16	12	
K (Frames per Multiframe)	32	32	32	32	32	32	32	32	32	32	32	32	32	
HD (High Density User Data Format)	1	1	1	1	1	1	1	1	1	1	1	1	1	

Table 17. Data Structure per Lane for F = 1 JESD204B Operating Modes<sup>1</sup>

JESD204B Mode and Parameters	Link Logical Lane	Frame 0, Octet 0	Frame 1, Octet 0
L = 4, M = 2, S = 1, NP = 16, N = 16 Mode 8: N = 16	Lane 0	M0S0[15:8]	M0S1[15:8]
	Lane 1	M0S0[7:0]	M0S1[7:0]
	Lane 2	M1S0[15:8]	M1S1[15:8]
	Lane 3	M1S0[7:0]	M1S1[7:0]
Mode 10 (L = 8, M = 2, S = 2, NP = 16, N = 16)	Lane 0	M0S0[15:8]	M0S2[15:8]
	Lane 1	M0S0[7:0]	M0S2[7:0]
	Lane 2	M0S1[15:8]	M0S3[15:8]
	Lane 3	M0S1[7:0]	M0S3[7:0]
	Lane 4	M1S0[15:8]	M1S2[15:8]
	Lane 5	M1S0[7:0]	M1S2[7:0]
	Lane 6	M1S1[15:8]	M1S3[15:8]
	Lane 7	M1S1[7:0]	M1S3[7:0]

JESD204B Mode and Parameters	Link Logical Lane	Frame 0, Octet 0	Frame 1, Octet 0
Mode 18 (L = 4, M = 1, S = 2, NP = 16, N = 16)	Lane 0	M0S0[15:8]	M0S2[15:8]
	Lane 1	M0S0[7:0]	M0S2[7:0]
	Lane 2	M0S1[15:8]	M0S3[15:8]
	Lane 3	M0S1[7:0]	M0S3[7:0]
Mode 20 (L = 8, M = 1, S = 4, NP = 16, N = 16)	Lane 0	M0S0[15:8]	M0S4[15:8]
	Lane 1	M0S0[7:0]	M0S4[7:0]
	Lane 2	M0S1[15:8]	M0S5[15:8]
	Lane 3	M0S1[7:0]	M0S5[7:0]
	Lane 4	M0S2[15:8]	M0S6[15:8]
	Lane 5	M0S2[7:0]	M0S6[7:0]
	Lane 6	M0S3[15:8]	M0S7[15:8]
	Lane 7	M0S3[7:0]	M0S7[7:0]

<sup>1</sup> Mx is the converter number and Sy is the sample number. For example, M0S0 means Converter 0, Sample 0.

**Table 18. Data Structure per Lane for F = 2 JESD204B Operating Modes<sup>1</sup>**

JESD204B Mode and Parameters	Link Logical Lane	Frame 0		Frame 1	
		Octet 0	Octet 1	Octet 0	Octet 2
Mode 3 (L = 2, M = 2, S = 1, NP = 16, N = 16)	Lane 0	M0S0[15:8]	M0S0[7:0]	M0S1[15:8]	M0S1[7:0]
	Lane 1	M1S0[15:8]	M1S0[7:0]	M1S1[15:8]	M1S1[7:0]
Mode 4 (L = 4, M = 4, S = 1, NP = 16, N = 16)	Lane 0	M0S0[15:8]	M0S0[7:0]	M0S1[15:8]	M0S1[7:0]
	Lane 1	M1S0[15:8]	M1S0[7:0]	M1S1[15:8]	M1S1[7:0]
	Lane 2	M2S0[15:8]	M2S0[7:0]	M2S1[15:8]	M2S1[7:0]
	Lane 3	M3S0[15:8]	M3S0[7:0]	M3S1[15:8]	M3S1[7:0]
Mode 9 (L = 4, M = 2, S = 2, NP = 16, N = 16)	Lane 0	M0S0[15:8]	M0S0[7:0]	M0S2[15:8]	M0S2[7:0]
	Lane 1	M0S1[15:8]	M0S1[7:0]	M0S3[15:8]	M0S3[7:0]
	Lane 2	M1S0[15:8]	M1S0[7:0]	M1S2[15:8]	M1S2[7:0]
	Lane 3	M1S1[15:8]	M1S1[7:0]	M1S3[15:8]	M1S3[7:0]
Mode 11 (L = 8, M = 2, S = 4, NP = 16, N = 16)	Lane 0	M0S0[15:8]	M0S0[7:0]	M0S4[15:8]	M0S4[7:0]
	Lane 1	M0S1[15:8]	M0S1[7:0]	M0S5[15:8]	M0S5[7:0]
	Lane 2	M0S2[15:8]	M0S2[7:0]	M0S6[15:8]	M0S6[7:0]
	Lane 3	M0S3[15:8]	M0S3[7:0]	M0S7[15:8]	M0S7[7:0]
	Lane 4	M1S0[15:8]	M1S0[7:0]	M1S4[15:8]	M1S4[7:0]
	Lane 5	M1S1[15:8]	M1S1[7:0]	M1S5[15:8]	M1S5[7:0]
	Lane 6	M1S2[15:8]	M1S2[7:0]	M1S6[15:8]	M1S6[7:0]
	Lane 7	M1S3[15:8]	M1S3[7:0]	M1S7[15:8]	M1S7[7:0]
Mode 19 (L = 4, M = 1, S = 4, NP = 16, N = 16)	Lane 0	M0S0[15:8]	M0S0[7:0]	M0S4[15:8]	M0S4[7:0]
	Lane 1	M0S1[15:8]	M0S1[7:0]	M0S5[15:8]	M0S5[7:0]
	Lane 2	M0S2[15:8]	M0S2[7:0]	M0S6[15:8]	M0S6[7:0]
	Lane 3	M0S3[15:8]	M0S3[7:0]	M0S7[15:8]	M0S7[7:0]
Mode 21 (L = 8, M = 1, S = 8, NP = 16, N = 16)	Lane 0	M0S0[15:8]	M0S0[7:0]	M0S8[15:8]	M0S8[7:0]
	Lane 1	M0S1[15:8]	M0S1[7:0]	M0S9[15:8]	M0S9[7:0]
	Lane 2	M0S2[15:8]	M0S2[7:0]	M0S10[15:8]	M0S10[7:0]
	Lane 3	M0S3[15:8]	M0S3[7:0]	M0S11[15:8]	M0S11[7:0]
	Lane 4	M0S4[15:8]	M0S4[7:0]	M0S12[15:8]	M0S12[7:0]
	Lane 5	M0S5[15:8]	M0S5[7:0]	M0S13[15:8]	M0S13[7:0]
	Lane 6	M0S6[15:8]	M0S6[7:0]	M0S14[15:8]	M0S14[7:0]
	Lane 7	M0S7[15:8]	M0S7[7:0]	M0S15[15:8]	M0S15[7:0]

<sup>1</sup> Mx is the converter number and Sy is the sample number. For example, M0S0 means Converter 0, Sample 0.

Table 19. Data Structure per Lane for F = 3 JESD204B Operating Modes<sup>1</sup>

JESD204B Mode and Parameters	Link Logical Lane	Frame 0					
		Octet 0		Octet 1		Octet 2	
		Nibble 0	Nibble1	Nibble 0	Nibble1	Nibble 0	Nibble1
Mode 5 (L = 1, M = 2, S = 1, NP = 12, N = 12)	Lane 0	M0S0[11:8]	M0S0[7:4]	M0S0[3:0]	M1S0[11:8]	M1S0[7:4]	M1S0[3:0]
Mode 6 (L = 2, M = 4, S = 1, NP = 12, N = 12)	Lane 0	M0S0[11:8]	M0S0[7:4]	M0S0[3:0]	M1S0[11:8]	M1S0[7:4]	M1S0[3:0]
	Lane 1	M2S0[11:8]	M2S0[7:4]	M2S0[3:0]	M3S0[11:8]	M3S0[7:4]	M3S0[3:0]
Mode 22 (L = 4, M = 2, S = 4, NP = 12, N = 12)	Lane 0	M0S0[11:8]	M0S0[7:4]	M0S0[3:0]	M0S1[11:8]	M0S1[7:4]	M0S1[3:0]
	Lane 1	M0S2[11:8]	M0S2[7:4]	M0S2[3:0]	M0S3[11:8]	M0S3[7:4]	M0S3[3:0]
	Lane 2	M1S0[11:8]	M1S0[7:4]	M1S0[3:0]	M1S1[11:8]	M1S1[7:4]	M1S1[3:0]
	Lane 3	M1S2[11:8]	M1S2[7:4]	M1S2[3:0]	M1S3[11:8]	M1S3[7:4]	M1S3[3:0]
Mode 12 (L = 8, M = 2, S = 8, NP = 12, N = 12)	Lane 0	M0S0[11:8]	M0S0[7:4]	M0S0[3:0]	M0S1[11:8]	M0S1[7:4]	M0S1[3:0]
	Lane 1	M0S2[11:8]	M0S2[7:4]	M0S2[3:0]	M0S3[11:8]	M0S3[7:4]	M0S3[3:0]
	Lane 2	M0S4[11:8]	M0S4[7:4]	M0S4[3:0]	M0S5[11:8]	M0S5[7:4]	M0S5[3:0]
	Lane 3	M0S6[11:8]	M0S6[7:4]	M0S6[3:0]	M0S7[11:8]	M0S7[7:4]	M0S7[3:0]
	Lane 4	M1S0[11:8]	M1S0[7:4]	M1S0[3:0]	M1S1[11:8]	M1S1[7:4]	M1S1[3:0]
	Lane 5	M1S2[11:8]	M1S2[7:4]	M1S2[3:0]	M1S3[11:8]	M1S3[7:4]	M1S3[3:0]
	Lane 6	M1S4[11:8]	M1S4[7:4]	M1S4[3:0]	M1S5[11:8]	M1S5[7:4]	M1S5[3:0]
Lane 7	M1S6[11:8]	M1S6[7:4]	M1S6[3:0]	M1S7[11:8]	M1S7[7:4]	M1S7[3:0]	

<sup>1</sup> Mx is the converter number and Sy is the sample number. For example, M0S0 means Converter 0, Sample 0.

Table 20. Data Structure per Lane for F = 4 JESD204B Operating Modes<sup>1</sup>

JESD204B Mode and Parameters	Link Logical Lane	Frame 0				Frame 1			
		Octet 0	Octet 1	Octet 2	Octet 3	Octet 0	Octet 1	Octet 2	Octet 3
Mode 0 (L = 1, M = 2, S = 1, NP = 16, N = 16)	Lane 0	M0S0[15:8]	M0S0[7:0]	M1S0[15:8]	M1S0[7:0]	M0S1[15:8]	M0S1[7:0]	M1S1[15:8]	M1S1[7:0]
Mode 1 (L = 2, M = 4, S = 1, NP = 16, N = 16)	Lane 0	M0S0[15:8]	M0S0[7:0]	M1S0[15:8]	M1S0[7:0]	M0S1[15:8]	M0S1[7:0]	M1S1[15:8]	M1S1[7:0]
	Lane 1	M2S0[15:8]	M2S0[7:0]	M3S0[15:8]	M3S0[7:0]	M2S1[15:8]	M2S1[7:0]	M3S1[15:8]	M3S1[7:0]
Mode 2 (L = 3, M = 6, S = 1, NP = 16, N = 16)	Lane 0	M0S0[15:8]	M0S0[7:0]	M1S0[15:8]	M1S0[7:0]	M0S1[15:8]	M0S1[7:0]	M1S1[15:8]	M1S1[7:0]
	Lane 1	M2S0[15:8]	M2S0[7:0]	M3S0[15:8]	M3S0[7:0]	M2S1[15:8]	M2S1[7:0]	M3S1[15:8]	M3S1[7:0]
	Lane 2	M4S0[15:8]	M4S0[7:0]	M5S0[15:8]	M5S0[7:0]	M4S1[15:8]	M4S1[7:0]	M5S1[15:8]	M5S1[7:0]

<sup>1</sup> Mx is the converter number and Sy is the sample number. For example, M0S0 means Converter 0, Sample 0.

Table 21. Data Structure per Lane for F = 8 JESD204B Operating Modes<sup>1</sup>

JESD204B Mode and Parameters	Link Logical Lane	Frame 0							
		Octet 0	Octet 1	Octet 2	Octet 3	Octet 4	Octet 5	Octet 6	Octet 7
Mode 7 (L = 1, M = 4, S = 1, NP = 16, N = 16)	Lane 0	M0S0[15:8]	M0S0[7:0]	M1S0[15:8]	M1S0[7:0]	M2S0[15:8]	M2S0[7:0]	M3S0[15:8]	M3S0[7:0]

<sup>1</sup> Mx is the converter number and Sy is the sample number. For example, M0S0 means Converter 0, Sample 0.

**PHYSICAL LAYER**

The physical layer of the JESD204B interface, hereafter referred to as the deserializer, has eight identical channels. Each channel consists of the termination, an equalizer, a clock and data recovery (CDR) circuit, and the 1:40 demux function (see Figure 53).

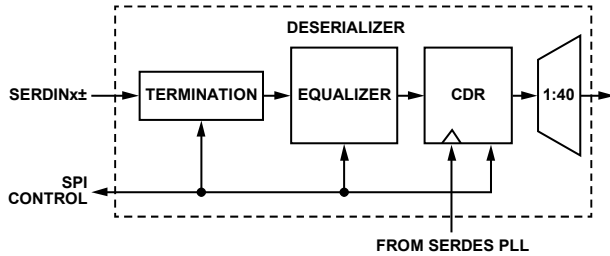

Figure 53. Deserializer Block Diagram

JESD204B data is input to the AD9174 via the SERDINx± differential input pins, per the JESD204B specification.

**Interface Power-Up and Input Termination**

Before using the JESD204B interface, it must be powered up by setting Register 0x200, Bit 0 = 0. In addition, each physical lane (PHY) that is not being used (SERDINx±) must be powered down. To do so, set the corresponding Bit x for Physical Lane x in Register 0x201 to 0 if the physical lane is being used, and to 1 if it is not being used.

The AD9174 autocalibrates the input termination to 100 Ω at dc. This calibration routine is performed automatically when the JESD204B interface blocks are configured and does not require any additional SPI register writes.

**Receiver Eye Mask**

The AD9174 is compatible with the JESD204B specification regarding the receiver eye mask and is capable of capturing data that complies with the mask in Figure 54. Figure 54 shows the receiver eye normalized to the data rate interval. The AD9174 also supports an increased insertion loss limit, as defined in the Equalization section.

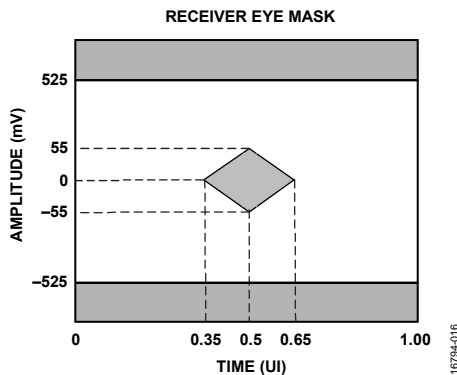

Figure 54. Receiver Eye Mask

**Clock Relationships**

The following clocks rates are used throughout the rest of the JESD204B section. The relationship between any of the clocks can be derived from the following equations:

$$Data\ Rate = DAC\ Rate / Total\ Interpolation$$

$$Lane\ Rate = (M/L) \times NP \times (10/8) \times Data\ Rate$$

$$Byte\ Rate = Lane\ Rate / 10$$

This relationship comes from 8-bit/10-bit encoding, where each byte is represented by 10 bits.

$$PCLK\ Rate = Byte\ Rate / 4 = Lane\ Rate / 40$$

The processing clock is used for a quad-byte decoder.

$$Frame\ Rate = Byte\ Rate / F$$

where *F* is defined as octets per frame per lane.

$$PCLK\ Factor = Frame\ Rate / PCLK\ Rate = 4 / F$$

where:

*M* is the JESD204B parameter for converters per link, which is the effective number of converters as seen by the JESD204B interface (not necessarily equal to the number of DAC cores).

*L* is the JESD204B parameter for lanes per link.

*F* is the JESD204B parameter for octets per frame per lane.

*NP* is the JESD204B parameter for the total number of bits per sample.

**SERDES PLL**

**Functional Overview of the SERDES PLL**

The independent SERDES PLL uses integer N techniques to achieve clock synthesis. The entire SERDES PLL is integrated on chip, including the VCO and the loop filter. The SERDES PLL is capable of providing quadrature clocks to allow a wide range of data rates (3 Gbps to 15.4 Gbps) with no gaps. These clocks are the input to the CDR block that is described in the Clock and Data Recovery section.

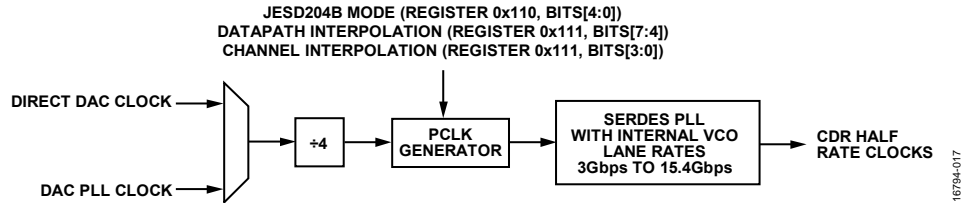

Figure 55. SERDES PLL Synthesizer Block Diagram Including VCO Divider Block

The reference clock to the SERDES PLL is always running at a frequency,  $f_{REF}$ , that is equal to  $1/40$  of the lane rate (PCLK rate). For more information about the SERDES circuitry setup and relevant register writes, see the Start-Up Sequence section. The SERDES PLL block automatically tunes to the appropriate divider range for the lane rate based on the SERDES mode being used. It takes the DAC clock generated by either the DAC PLL, if in use, or from the direct clock being sourced at the  $CLKIN_{\pm}$  pins, divides the DAC clock frequency by 4, and uses the JESD204B parameters corresponding to the mode and interpolation values programmed in Register 0x110 and Register 0x111 to determine the proper dividers for generating the PCLK frequency (lane rate  $\div$  40), as shown in Figure 55.

Confirm that the SERDES PLL is working by reading Register 0x281. If Register 0x281, Bit 0 = 1, the SERDES PLL has locked.

### Clock and Data Recovery

The deserializer is equipped with a CDR circuit. Instead of recovering the clock from the JESD204B serial lanes, the CDR recovers the clocks from the SERDES PLL. The SERDES PLL in turn uses the PCLK as its reference, where the PCLK is derived from the DAC clock. It is thus critical to lock the JESD204B transmitter clock to the device clock of the AD9174.

The CDR circuit synchronizes the phase used to sample the data on each serial lane independently. This independent phase adjustment per serial interface ensures accurate data sampling and eases the implementation of multiple serial interfaces on a PCB.

### Power-Down Unused PHYs

Any unused physical and enabled lanes consume extra power unnecessarily. Each lane that is not being used ( $SERDIN_{x\pm}$ ) must be powered off by writing a 1 to the corresponding bit of  $PHY\_PD$  (Register 0x201).

### Equalization

To compensate for signal integrity distortions for each PHY channel due to PCB trace length and impedance, the AD9174 employs an easy to use, low power equalizer on each JESD204B channel. The AD9174 equalizers operating at the maximum lane rate of 15.4 Gbps can compensate for up to 16 dB of insertion loss.

This equalizer performance is shown in Figure 56 for 15.4 Gbps, near the maximum baud rate for the AD9174. The channel must also meet the insertion loss deviation (also known as spectral ripple) requirement of the JESD204B specification (less than 1.5 dB from 50 MHz to 0.75 times the baud rate).

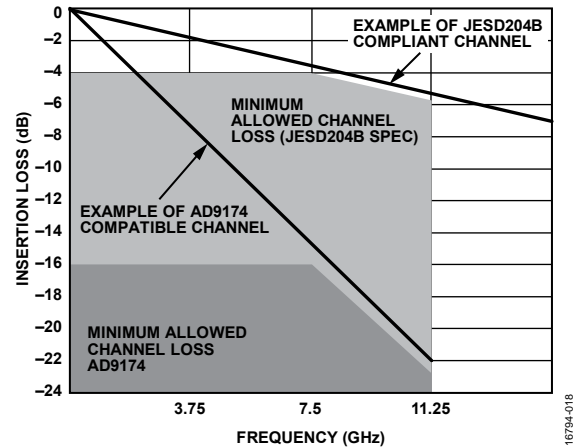

Figure 56. Insertion Loss Allowed

To ensure the AD9174 compensates for the amount of insertion loss in the system, set the equalizer block appropriately. Table 22 shows the settings for the equalizer boost, equalizer gain, and feedback controls, depending on the level of insertion loss in the system. The equalizer boost setting is programmed for each PHY lane (2-bit control for each) being used in Register 0x240 and Register 0x241. Similarly, the equalizer gain settings are programmed for each PHY lane (2-bit control for each) used in Register 0x242 and Register 0x243. The feedback control is programmed per PHY lane (5-bit control for each, one control per register) in Register 0x244 to Register 0x24B.

Table 22. Equalizer Register Control Settings per PHY Control

Insertion Loss	$\leq 11$ dB	$> 11$ dB
Equalizer Boost	0x02	0x03
Equalizer Gain	0x01	0x03
Feedback	0x1F	0x1F

Figure 57 and Figure 58 are provided as points of reference for hardware designers and show the insertion loss for various lengths of well laid out stripline and microstrip transmission lines, respectively. See the Hardware Considerations section for specific layout recommendations for the JESD204B channel.

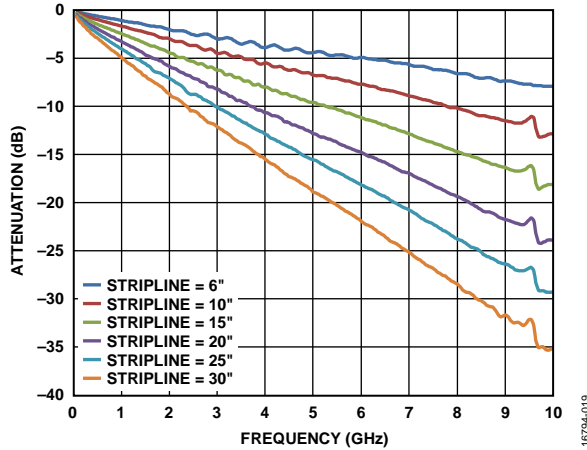

Figure 57. Insertion Loss of 50  $\Omega$  Striplines on FR4

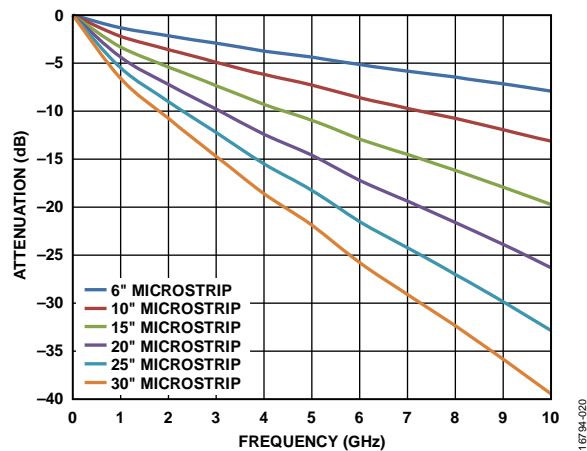

Figure 58. Insertion Loss of 50  $\Omega$  Microstrips on FR4

### DATA LINK LAYER

The data link layer of the AD9174 JESD204B interface accepts the deserialized data from the PHYs and deframes and descrambles the data so that data octets are presented to the transport layer to be recombined into the original data samples ahead of the DAC core. The architecture of the data link layer is shown in Figure 59. The data link layer consists of a synchronization FIFO for each lane, a crossbar switch, a deframer, and a descrambler.

The AD9174 can be set up to receive data from either a single-link or dual-link high speed JESD204B serial data interface. When operating in dual-link mode, the data link layer abstracts the interface to appear as two independent JESD204B links to the user, each occupying a maximum of four lanes. In either mode, all eight lanes of the JESD204B interface handle link layer communications such as code group synchronization (CGS), frame alignment, and frame synchronization.

The AD9174 decodes 8-bit/10-bit control characters, which mark the edges of the frame and help maintain alignment between serial lanes. Each AD9174 serial interface link can issue a synchronization request by setting its SYNCOUTx± signals low. The synchronization protocol follows Section 4.9 of the JESD204B standard. When a stream of four consecutive /K/ symbols is received, the AD9174 deactivates the synchronization request by setting the SYNCOUTx± signals high at the next internal LMFC rising edge. Then, the AD9174 waits for the transmitter to issue an initial lane alignment sequence (ILAS). During the ILAS, all lanes are aligned using the /A/ to /R/ character transition as described in the JESD204B Serial Link Establishment section. Elastic buffers hold early arriving lane data until the alignment character of the latest lane arrives. At this point, the buffers for all lanes are released and all lanes are aligned (see Figure 60).

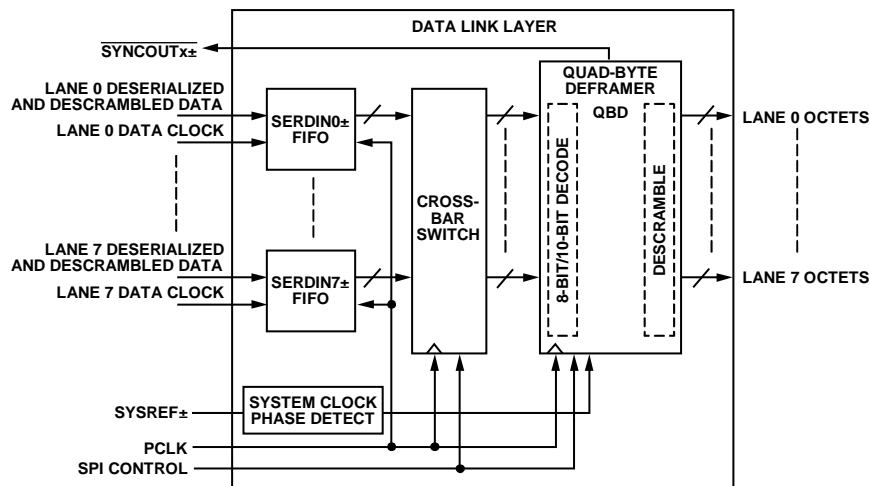

Figure 59. Data Link Layer Block Diagram

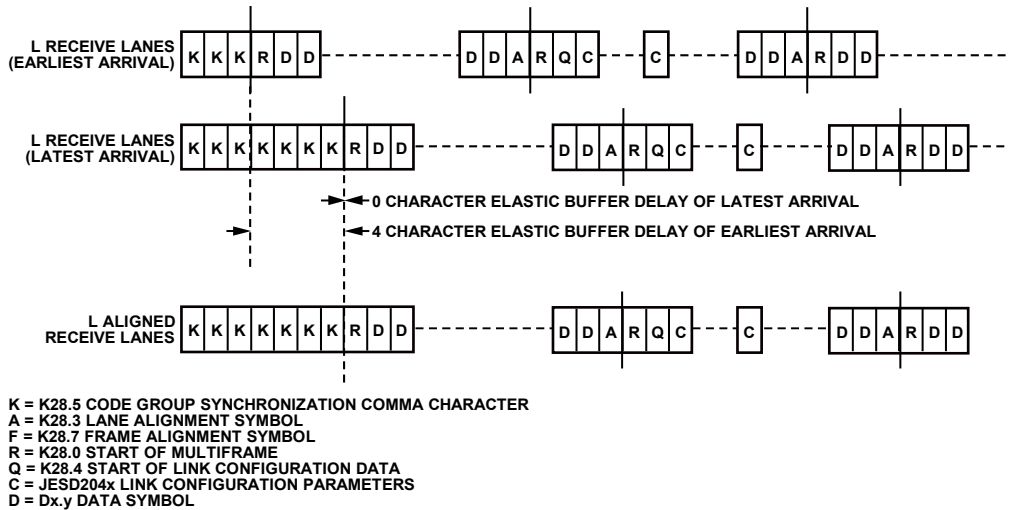

Figure 60. Lane Alignment During ILAS

### JESD204B Serial Link Establishment

A brief summary of the high speed serial link establishment process for Subclass 1 is provided. See Section 5.3.3 of the JESD204B specification document for complete details.

#### Step 1—Code Group Synchronization

Each receiver must locate /K/ (K28.5) characters in its input data stream. After four consecutive /K/ characters are detected on all link lanes, the receiver block deasserts the  $\overline{\text{SYNCOUTx}}_{\pm}$  signals to the transmitter block at the receiver LMFC edge.

The transmitter captures the change in the  $\overline{\text{SYNCOUTx}}_{\pm}$  signals and at a future transmitter LMFC rising edge, starts the ILAS.

#### Step 2—Initial Lane Alignment Sequence

The main purposes of this phase are to align all the lanes of the link and to verify the parameters of the link.

Before the link is established, write each of the link parameters to the receiver device to designate how data is sent to the receiver block.

The ILAS consists of four or more multiframe. The last character of each multiframe is a multiframe alignment character, /A/. The first, third, and fourth multiframe are populated with predetermined data values. Section 8.2 of the JESD204B specifications document describes the data ramp that is expected during the ILAS. The deframer uses the final /A/ of each lane to align the ends of the multiframe within the receiver. The second multiframe contains an /R/ (K.28.0), /Q/ (K.28.4), and then data corresponding to the link parameters. Additional multiframe can be added to the ILAS if needed by the receiver. By default, the AD9174 uses four multiframe in the ILAS (this can be changed in Register 0x478). If using Subclass 1, exactly four multiframe must be used.

After the last /A/ character of the last ILAS, multiframe data begins streaming. The receiver adjusts the position of the /A/ character such that it aligns with the internal LMFC of the receiver at this point.

#### Step 3—Data Streaming

In this phase, data is streamed from the transmitter block to the receiver block.

Optionally, data can be scrambled. Scrambling does not start until the first octet following the ILAS.

The receiver block processes and monitors the data it receives for errors, including the following:

- Bad running disparity (8-bit/10-bit error)
- Not in table (8-bit/10-bit error)
- Unexpected control character
- Bad ILAS
- Interlane skew error (through character replacement)

If any of these errors exist, they are reported back to the transmitter in one of the following ways (see the JESD204B Error Monitoring section for details):

- $\overline{\text{SYNCOUTx}}_{\pm}$  signal assertion: resynchronization ( $\overline{\text{SYNCOUTx}}_{\pm}$  signals pulled low) is requested at each error for the last two errors. For the first three errors, an optional resynchronization request can be asserted when the error counter reaches a set error threshold.
- For the first three errors, each multiframe with an error in it causes a small pulse on the respective  $\overline{\text{SYNCOUTx}}_{\pm}$  pins.
- Errors can optionally trigger an interrupt request (IRQ) event, which can be sent to the transmitter.

For more information about the various test modes for verifying the link integrity, see the JESD204B Test Modes section.

### Lane First In/First Out (FIFO)

The FIFOs in front of the crossbar switch and deframer synchronize the samples sent on the high speed serial data interface with the deframer clock by adjusting the phase of the incoming data. The FIFO absorbs timing variations between the data source and the deframer, which allows up to two PCLK cycles of drift from the transmitter. The FIFO\_STATUS\_REG\_0 register and FIFO\_STATUS\_REG\_1 register (Register 0x30C and Register 0x30D, respectively) can be monitored to identify whether the FIFOs are full or empty.

### Lane FIFO IRQ

An aggregate lane FIFO error bit is also available as an IRQ event. Use Register 0x020, Bit 2 to enable the lane FIFO error bit, and then use Register 0x024, Bit 2 to read back its status and reset the IRQ signal. See the Interrupt Request Operation section for more information.

### Crossbar Switch

Register 0x308 to Register 0x30B allow arbitrary mapping of physical lanes (SERDIN $x\pm$ ) to logical lanes used by the SERDES deframers.

**Table 23. Crossbar Registers**

Address	Bits	Logical Lane
0x308	[2:0]	SRC_LANE0
0x308	[5:3]	SRC_LANE1
0x309	[2:0]	SRC_LANE2
0x309	[5:3]	SRC_LANE3
0x30A	[2:0]	SRC_LANE4
0x30A	[5:3]	SRC_LANE5
0x30B	[2:0]	SRC_LANE6
0x30B	[5:3]	SRC_LANE7

Write each SRC\_LANE $y$  with the number ( $x$ ) of the desired physical lane (SERDIN $x\pm$ ) from which to obtain data. By default, all logical lanes use the corresponding physical lane as their data source. For example, by default, SRC\_LANE0 = 0. Therefore, Logical Lane 0 obtains data from Physical Lane 0 (SERDIN0 $\pm$ ). To use SERDIN4 $\pm$  as the source for Logical Lane 0 instead, the user must write SRC\_LANE0 = 4.

### Lane Inversion

Register 0x334 allows inversion of desired logical lanes, which can be used to ease routing of the SERDIN $x\pm$  signals. For each Logical Lane  $x$ , set Bit  $x$  of Register 0x334 to 1 to invert it.

### Deframer

The AD9174 consists of two quad-byte deframers (QBDs) paged by the LINK\_PAGE control in Register 0x300, Bit 2. The deframer accepts the 8-bit/10-bit encoded data from the deserializer (via the crossbar switch), decodes it, and descrambles it into JESD204B frames before passing it to the transport layer to be converted to DAC samples. The deframer processes four symbols (or octets) per processing clock (PCLK) cycle.

The deframer uses the JESD204B parameters that the user has programmed into the register map to identify how the data is packed, and unpacks it. The JESD204B parameters are described in detail in the Transport Layer section. Many of the parameters are also needed in the transport layer to convert JESD204B frames into samples.

### Descrambler

The AD9174 provides an optional descrambler block using a self synchronous descrambler with the following polynomial:  
 $1 + x^{14} + x^{15}$ .

Enabling data scrambling reduces spectral peaks that are produced when the same data octets repeat from frame to frame. It also makes the spectrum data independent so that possible frequency selective effects on the electrical interface do not cause data dependent errors. Descrambling of the data is enabled by setting the SCR bit (Register 0x453, Bit 7) to 1.

### SYNCING LMFC SIGNALS

The AD9174 requires a synchronization (sync) to align the LMFC and other internal clocks before the SERDES links are brought online. The synchronization is a one-shot sync, where the synchronization process begins on the next edge of the alignment signal following the assertion of the SYSREF\_MODE\_ONESHOT control in Register 0x03A, Bit 1.

In Subclass 1, the SYSREF $\pm$  rising edge acts as the alignment edge. In Subclass 0, an internal processing clock acts as the alignment edge. When a sync has completed, the SYNC\_ROTATION\_DONE (Register 0x03A, Bit 4) bit is asserted and remains asserted until another sync is requested.

After a synchronization occurs, the JESD204B link can be enabled. In Subclass 1, the latency of the JESD204B system is deterministic and allows synchronization across multiple devices, if desired.

### SYSREF $\pm$ Signal

The SYSREF $\pm$  signal is a differential source synchronous input that synchronizes the LMFC signals in both the transmitter and receiver in a JESD204B Subclass 1 system to achieve deterministic latency.

The SYSREF $\pm$  signal is a rising edge sensitive signal that is sampled by the device clock rising edge. It is best practice that the device clock and SYSREF $\pm$  signals be generated by the same source, such as the HMC7044 clock generator, so that the phase alignment between the signals is fixed. When designing for optimum deterministic latency operation, consider the timing distribution skew of the SYSREF $\pm$  signal in a multipoint link system (multichip).

The AD9174 supports a periodic SYSREF± signal. The periodicity can be continuous, strobed, or gapped periodic. The SYSREF± signal can be dc-coupled with a common-mode voltage of 0.6 V to 2.2 V and differential swing of 200 mV p-p to 1 V p-p. When dc-coupled, a small amount of common-mode current (up to 0.3 mA) is drawn from the SYSREF± pins. See Figure 61 and Figure 62 for the SYSREF± internal circuit for dc-coupled and a c-coupled configurations. Ensure that the SYSREF\_INPUTMODE bit (Register 0x084, Bit 6) is set to 1, dc-coupled, to prevent overstress on the SYSREF± receiver pins.

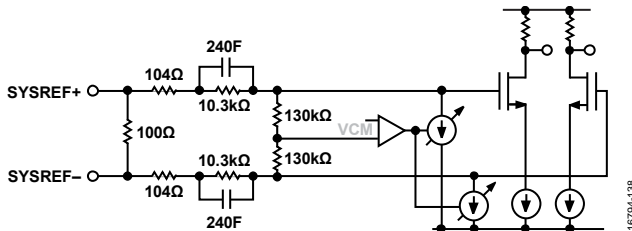

Figure 61. DC-Coupled SYSREF± Receiver Circuitry

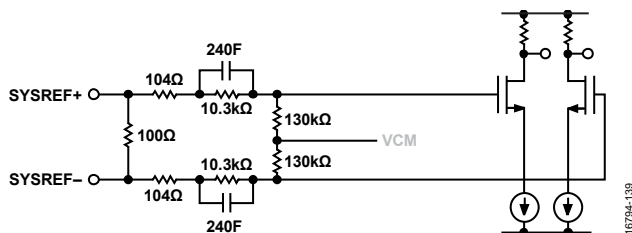

Figure 62. AC-Coupled SYSREF± Receiver Circuitry

To avoid this common-mode current draw, the SYSREF± receiver can be ac-coupled using a 50% duty cycle periodic SYSREF± signal with ac coupling capacitors. If ac-coupled, the ac coupling capacitors combine with the resistors shown in Figure 62 to make a high-pass filter with an RC time constant of  $\tau = RC$ . Select C such that  $\tau > 4/\text{SYSREF}\pm$  frequency. In addition, the edge rate must be sufficiently fast to allow SYSREF± sampling clocks to correctly sample the rising SYSREF± edge before the next sample clock.

When ac coupling the SYSREF± inputs, ensure that the SYSREF\_INPUTMODE bit (Register 0x084, Bit 6) is set to 0, ac-coupled, to enable the internal receiver biasing circuitry and prevent overstress on the SYSREF± receiver pins. AC coupling allows a differential voltage swing from 200 mV to 1 V on the SYSREF± pins.

### SYSREF± Sampling

The SYSREF± signal is sampled by a divide by 4 version of the DAC clock. Thus, the minimum pulse width of the SYSREF± signal must exceed 4 DAC clock periods to ensure accurate sampling. The delay between the SYSREF± and DAC clock input signal does not need to be timing constrained.

By default, the first SYSREF± rising edge at the SYSREF± inputs that is detected after asserting the SYSREF\_MODE\_ONESHOT bit (Register 0x03A, Bit 1) begins the synchronization and aligns the internal LMFC signal with the sampled SYSREF± edge.

Register 0x036 (SYSREF\_COUNT) indicates how many captured SYSREF± edges are ignored after the SYSREF\_MODE\_ONESHOT bit is asserted before the synchronization takes place. For example, if SYSREF\_COUNT is set to 3, the AD9174 does not sync after the SYSREF\_MODE\_ONESHOT bit is asserted until the arrival of the 4th SYSREF± edge.

### SYSREF± Jitter IRQ

In Subclass 1, after the one-shot synchronization occurs, the SYSREF± signal is monitored to ensure that the subsequent SYSREF± edges do not deviate from the internal LMFC clock by more than a target amount.

Register 0x039 (SYSREF\_ERR\_WINDOW) indicates the size of the error window allowed, in DAC clock units. If a SYSREF± edge varies from the internal LMFC clock by more than the number of DAC clock units set in SYSREF\_ERR\_WINDOW, the IRQ\_SYSREF\_JITTER is asserted.

Table 24. SYSREF± Jitter Window Tolerance

SYSREF± Jitter Window Tolerance (DAC Clock Cycles)	SYSREF_ERR_WINDOW (Register 0x039, Bits[5:0]) <sup>1</sup>
±½	0x00
±4	0x04
±8	0x08
±12	0x0C
±16	0x10
±20	0x14
+24	0x18
±28	0x1C

<sup>1</sup> The two least significant digits are ignored because the SYSREF± signal is sampled with a divide by 4 version of the DAC clock. As a result, the jitter window is set by this divide by 4 clock rather than the DAC clock. It is recommended that at least a four-DAC clock SYSREF± jitter window be chosen.

The IRQ\_SYSREF\_JITTER can be configured as described in the Interrupt Request Operation section to indicate the SYSREF± signal has varied, and to request the SPI sequence for a sync be performed again.

### Sync Procedure

The procedure for enabling the sync is as follows:

1. Set up the DAC and the SERDES PLL, and enable the CDR (see the Start-Up Sequence section).
2. Set Register 0x03B to 0xF1 to enable the synchronization circuitry. If using the soft on/off feature, set Register 0x03B to 0xF3 to ramp the datapath data before and after the synchronization.

3. If Subclass 1, configure the SYSREF± settings as follows:
  - a. Set Register 0x039 (SYSREF± jitter window). See Table 24 for settings.
  - b. Set Register 0x036 = SYSREF\_COUNT. Leave the setting as 0 to bypass.
4. Perform a one-shot sync.
  - a. Set Register 0x03A = 0x00. Clear one-shot mode if already enabled.
  - b. Set Register 0x03A = 0x02. Enable one-shot sync mode.
5. If Subclass 1, send a SYSREF± edge. If pulse counting, multiple SYSREF± edges are required. Sending SYSREF± edges triggers the synchronization.
6. Read back the SYNC\_ROTATION\_DONE bit (Register 0x03A, Bit 4) to confirm the rotation occurred.

**Resynchronizing LMFC Signals**

If desired, the sync procedure can be repeated to realign the LMFC clock to the reference signal by repeating Step 2 to Step 6, described in the Sync Procedure section. When the one-shot sync is armed (writing Register 0x03A = 0x02), the SYNCOUTx± signals deassert to drop the JESD204B links and reassert after the rotation completes.

**Deterministic Latency**

JESD204B systems contain various clock domains distributed throughout. Data traversing from one clock domain to a different clock domain can lead to ambiguous delays in the JESD204B link. These ambiguities lead to nonrepeatable latencies across the link from power cycle to power cycle with each new link establishment. Section 6 of the JESD204B specification addresses the issue of deterministic latency with mechanisms defined as Subclass 1 and Subclass 2.

The AD9174 supports JESD204B Subclass 0 and Subclass 1 operation, but not Subclass 2. Write the subclass to Register 0x458, Bits[7:5].

**Subclass 0**

Subclass 0 mode provides deterministic latency to within several PCLK cycles. It does not require any signal on the SYSREF± pins, which can be left disconnected.

Subclass 0 still requires that all lanes arrive within the same LMFC cycle and the dual DACs must be synchronized to each other.

**Subclass 1**

This mode gives deterministic latency and allows the link to be synchronized to within a few DAC clock cycles. Across the full operating range, for both supply and temperature, it is within ±2.5 DAC clock periods for a 6 GHz DAC clock rate or ±4 DAC clock periods for a 12.6 GHz DAC clock rate. If both supply and temperature stability are maintained, the link can be synchronized to within ±1.5 DAC clock periods for a 6 GHz DAC clock rate or ±2.5 DAC clock periods for a 12.6 GHz DAC clock rate. Achieving this latency requires an external, low jitter SYSREF± signal that is accurately phase aligned to the DAC clock.

**Deterministic Latency Requirements**

Several key factors are required for achieving deterministic latency in a JESD204B Subclass 1 system, as follows:

- The SYSREF± signal distribution skew within the system must be less than the desired uncertainty.
- The total latency variation across all lanes, links, and devices must be ≤12 PCLK periods, which includes both variable delays and the variation in fixed delays from lane to lane, link to link, and device to device in the system.

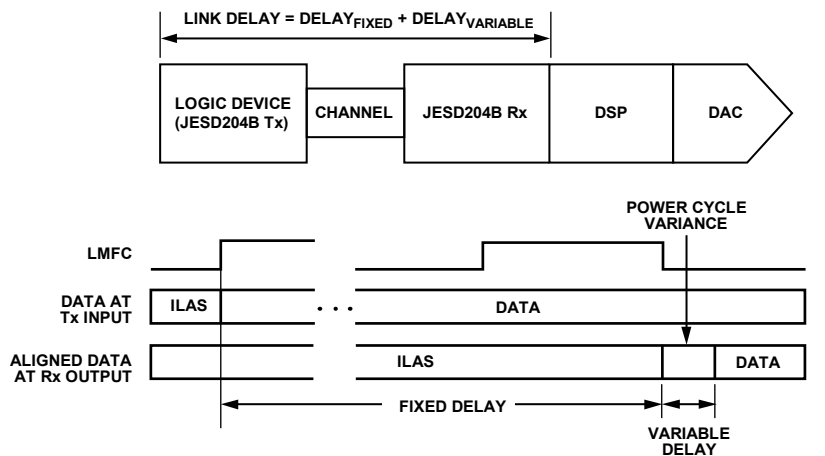

Figure 63. JESD204B Link Delay = Fixed Delay + Variable Delay

## Link Delay

The link delay of a JESD204B system is the sum of the fixed and variable delays from the transmitter, channel, and receiver as shown in Figure 63.

For proper functioning, all lanes on a link must be read during the same LMFC period. Section 6.1 of the JESD204B specification states that the LMFC period must be larger than the maximum link delay. For the AD9174, this is not necessarily the case. Instead, the AD9174 use a local LMFC for each link ( $LMFC_{Rx}$ ) that can be delayed from the  $SYSREF_{\pm}$  aligned LMFC. Because the LMFC is periodic, this delay can account for any amount of fixed delay. As a result, the LMFC period must only be larger than the variation in the link delays, and the AD9174 can achieve proper performance with a smaller total latency. Figure 64 and Figure 65 show a case where the link delay is greater than an LMFC period. The link delay can be accommodated by delaying  $LMFC_{Rx}$ .

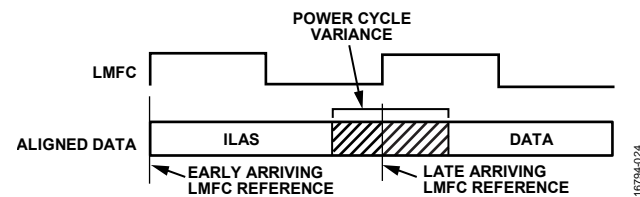

Figure 64. Link Delay > LMFC Period Example

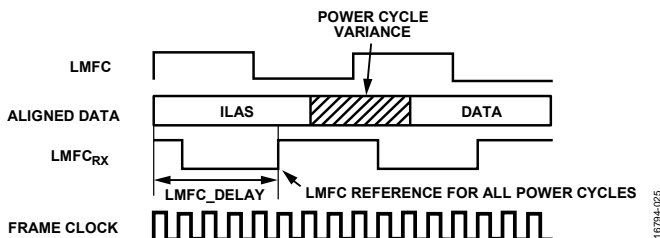

Figure 65.  $LMFC\_DELAY_x$  to Compensate for Link Delay > LMFC

The method to select the  $LMFCDel$  (Register 0x304) and  $LMFCVar$  (Register 0x306) variables is described in the Link Delay Setup Example, with Known Delays section and the Link Delay Setup Example, Without Known Delay section. The setting for  $LMFCDel$  must not equal or exceed the number of PCLK cycles per LMFC period in the current mode. Similarly,  $LMFCVar$  must not exceed the number of PCLK cycles per LMFC period in the current mode or be set to <12 (whichever value is smaller).

Setting  $LMFCDel$  appropriately ensures that all the corresponding data samples arrive in the same LMFC period. Then,  $LMFCVar$  is written into the receive buffer delay (RBD) to absorb all link delay variation. This write ensures that all data samples arrived before reading. By setting these to fixed values across runs and devices, deterministic latency is achieved.

The RBD described in the JESD204B specification takes values from one frame clock cycle to  $/K/$  frame clock cycles, and the RBD of the AD9174 takes values from 0 PCLK cycle to 12 PCLK cycles. As a result, up to 12 PCLK cycles of total delay variation can be absorbed.  $LMFCVar$  and  $LMFCDel$  are both in PCLK

cycles. The PCLK factor, or number of frame clock cycles per PCLK cycle, is equal to  $4/f$ . For more information on this relationship, see the Clock Relationships section.

Two examples follow that show how to determine  $LMFCVar$  and  $LMFCDel$ . After they are calculated, write  $LMFCDel$  into Register 0x304 for all devices in the system, and write  $LMFCVar$  to Register 0x306 for all devices in the system.

### Link Delay Setup Example, with Known Delays

All the known system delays can be used to calculate  $LMFCVar$  and  $LMFCDel$ .

The example shown in Figure 66 is demonstrated in the following steps. This example is in Subclass 1 to achieve deterministic latency, and the example uses the case for  $F = 2$ . Therefore, the number of PCLK cycles per multiframe = 16. Because  $PCBFixed \ll PCLK$  Period,  $PCBFixed$  is negligible in this example and not included in the calculations.

- Find the receiver delays using Table 6.
 
$$RxFixed = 13 \text{ PCLK cycles}$$

$$RxVar = 2 \text{ PCLK cycles}$$
  - Find the transmitter delays. The equivalent table in the example JESD204B core (implemented on a GTH or GTX gigabit transceiver on a Virtex-6 FPGA) states that the delay is  $56 \pm 2$  byte clock cycles.
 
$$TxFixed = 54/4 = 13.5 \text{ PCLK cycles}$$

$$TxVar = 4/4 = 1 \text{ PCLK cycle}$$
  - Calculate  $MinDelayLane$  as follows:
 
$$MinDelayLane = \text{floor}(RxFixed + TxFixed + PCBFixed)$$

$$= \text{floor}(13 + 13.5 + 0)$$

$$= \text{floor}(26.5)$$

$$MinDelayLane = 26$$
  - Calculate  $MaxDelayLane$  as follows:
 
$$MaxDelayLane = \text{ceiling}(RxFixed + RxVar + TxFixed + TxVar + PCBFixed)$$

$$= \text{ceiling}(13 + 2 + 13.5 + 1 + 0)$$

$$= \text{ceiling}(29.5)$$

$$MaxDelayLane = 30$$
  - Calculate  $LMFCVar$  as follows:
 
$$LMFCVar = (MaxDelay + 1) - (MinDelay - 1)$$

$$= (30 + 1) - (26 - 1) = 31 - 25$$

$$LMFCVar = 6 \text{ PCLK cycles}$$
  - Calculate  $LMFCDel$  as follows:
 
$$LMFCDel = (MinDelay - 1) \% (PCLKsperMF)$$

$$= ((26 - 1)) \% 16$$

$$= 25 \% 16$$

$$LMFCDel = 9 \text{ PCLK cycles}$$
- Write  $LMFCDel$  to Register 0x304 for all devices in the system. Write  $LMFCVar$  to Register 0x306 for all devices in the system.

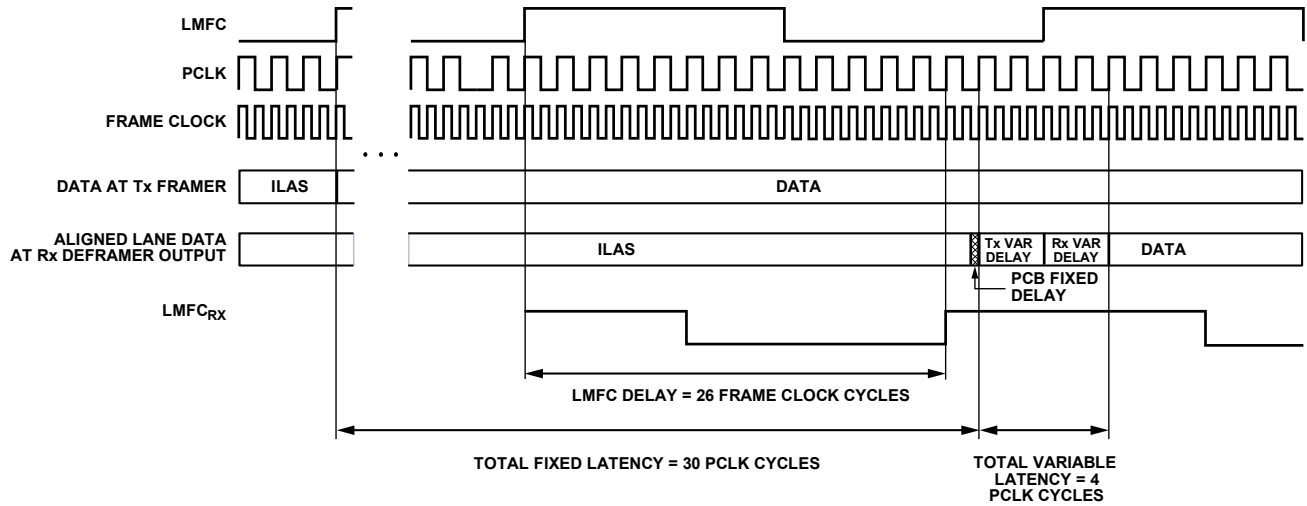

Figure 66. LMFC Delay Calculation Example

16794-026

**Link Delay Setup Example, Without Known Delay**

If the system delays are not known, the AD9174 can read back the link latency between LMFC<sub>Rx</sub> for each link (with the LMFCDel setting subtracted out) and the SYSREF± aligned LMFC. This information is then used to calculate LMFCVar and LMFCDel.

Figure 68 shows how DYN\_LINK\_LATENCY\_0 (Register 0x302) provides a readback showing the delay (in PCLK cycles) between LMFC<sub>Rx</sub> minus the LMFC\_DELAY\_x (fixed delay) setting set in the SPI at that time and the transition from the ILAS to the first data sample. By repeatedly power cycling and taking this measurement, the minimum and maximum delays across power cycles can be determined and used to calculate LMFCVar and LMFCDel.

In Figure 68, for Link A, Link B, and Link C, the system containing the AD9174 (including the transmitter) is power cycled and configured 20 times. The AD9174 is configured as described in the Sync Procedure section. Because the purpose of this exercise is to determine LMFCDel and LMFCVar, the LMFCDel value is programmed to 0 and the DYN\_LINK\_LATENCY\_0 value is read from Register 0x302. The variation in the link latency over the 20 runs is shown in Figure 68, described as follows:

- Link A gives readbacks of 6, 7, 0, and 1. The set of recorded delay values rolls over the edge of a multiframe at the boundary of K/PCLK factor = 8. Add the number of PCLK cycles per multiframe = 8 to the readback values of 0 and 1 because they rolled over the edge of the multiframe. Delay values range from 6 to 9.
- Link B gives delay values from 5 to 7.
- Link C gives delay values from 4 to 7.

The example shown in Figure 68 is demonstrated in the following steps. This example is in Subclass 1 to achieve deterministic latency, and the example uses the case for F = 1. Therefore, the number of PCLK cycles per multiframe = 8.

1. Calculate the minimum of all delay measurements across all power cycles, links, and devices as follows:  
 $MinDelay = \min(\text{all Delay values}) = 4$
2. Calculate the maximum of all delay measurements across all power cycles, links, and devices as follows:  
 $MaxDelay = \max(\text{all Delay values}) = 9$
3. Set LMFCVar to the maximum of 12 PCLK cycles. If latency is required to be minimized for a given application, calculate the total delay variation (with 2 PCLK cycles of guard band on each end) across all power cycles, links, and devices as follows:  
 $LMFCVar = (MaxDelay + 2) - (MinDelay - 2)$   
 $= (9 + 2) - (4 - 2) = 11 - 2 = 9 \text{ PCLK cycles}$
4. Calculate the minimum delay in PCLK cycles (with 2 PCLK cycles of guard band) across all power cycles, links, and devices as follows:  
 $LMFCDel = (MinDelay - 2) \% (PCLKsperMF)$   
 $= (4 - 2) \% 8$   
 $= 2 \% 8 = 2 \text{ PCLK cycles}$
5. Write LMFCDel to Register 0x304 for all devices in the system. Write LMFCVar to Register 0x306 for all devices in the system.

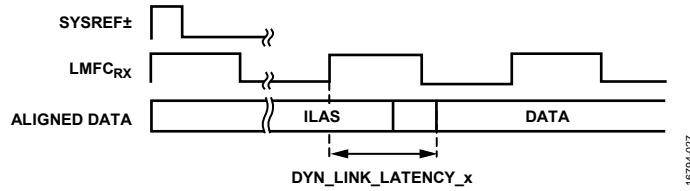

Figure 67. DYN\_LINK\_LATENCY\_x Illustration

16794-027

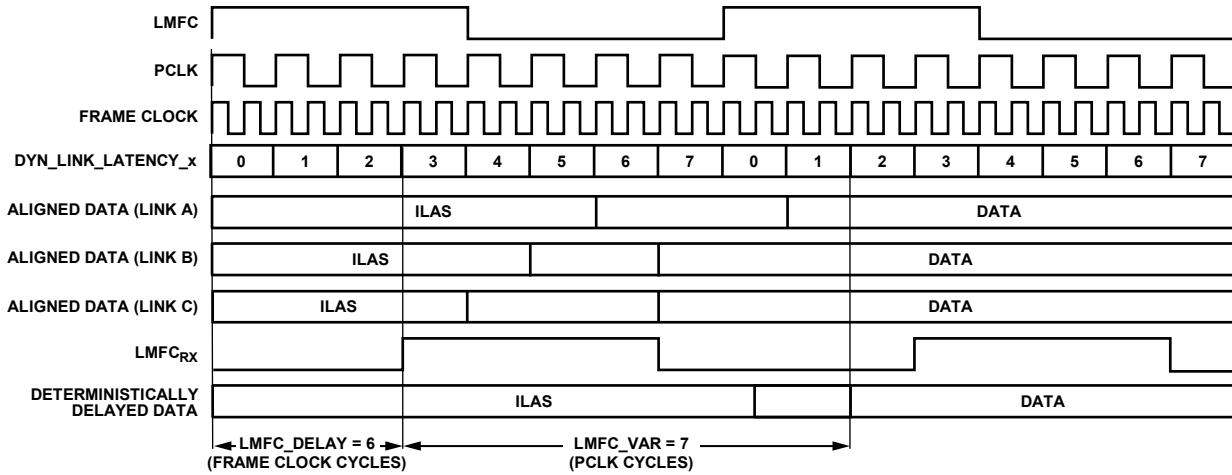

Figure 68. Multilink Synchronization Settings, Derived Method Example

16794-028

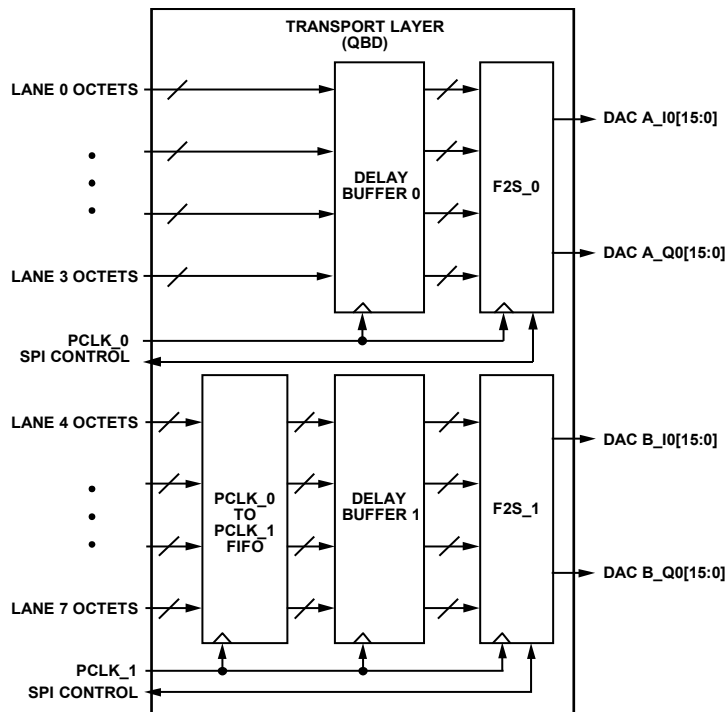

Figure 69. Transport Layer Block Diagram

16794-029

**TRANSPORT LAYER**

The transport layer receives the descrambled JESD204B frames and converts them to DAC samples based on the programmed JESD204B parameters shown in Table 25. The device parameters are defined in Table 26.

**Table 25. JESD204B Transport Layer Parameters**

Parameter	Description
F	Number of octets per frame per lane: 1, 2, 3, 4 or 8.
K	Number of frames per multiframe: $K = 32$ .
L	Number of lanes per converter device (per link), as follows: 1, 2, 3, 4 or 8.
M	Number of converters per device (per link), as follows: For real data modes, M is the number of real data converters (if total interpolation is 1x). For complex data modes, M is the number of complex data subchannels, I or Q.
S	Number of samples per converter, per frame: 1, 2, 4 or 8.

**Table 26. JESD204B Device Parameters**

Parameter	Description
CF	Number of control words per device clock per link. Not supported, must be 0.
CS	Number of control bits per conversion sample. Not supported, must be 0.
HD	High density user data format. This parameter is always set to 1.
N	Converter resolution.
N' (or NP)	Total number of bits per sample.

Certain combinations of these parameters are supported by the AD9174. See Table 28 and Table 29 for a list of supported single-link and dual-link modes, respectively. Table 28 and Table 29 lists the JESD204B parameters for each of the modes. Table 27 lists JESD204B parameters that have fixed values.

**Table 27. JESD204B Parameters with Fixed Values**

Parameter	Value
K	32
CF	0
HD	1
CS	0

**Table 28. Single-Link JESD204B Operating Modes**

Parameter	Single-Link JESD204B Modes																	
	0	1	2	3	4	5	6	7	8	9	10	11	12	18	19	20	21	22
L (Lane Count)	1	2	3	2	4	1	2	1	4	4	8	8	8	4	4	8	8	4
M (Converter Count)	2	4	6	2	4	2	4	4	2	2	2	2	2	1	1	1	1	2
F (Octets per Frame per Lane)	4	4	4	2	2	3	3	8	1	2	1	2	3	1	2	1	2	3
S (Samples per Converter per Frame)	1	1	1	1	1	1	1	1	1	2	2	4	8	2	4	4	8	4
NP (Total Number of Bits per Sample)	16	16	16	16	16	12	12	16	16	16	16	16	12	16	16	16	16	12
N (Converter Resolution)	16	16	16	16	16	12	12	16	16	16	16	16	12	16	16	16	16	12

**Table 29. Dual-Link JESD204B Operating Modes**

Parameter	Dual-Link JESD204B Modes													
	0	1	2	3	4	5	6	7	8	9	18	19	22	
L (Lane Count)	1	2	3	2	4	1	2	1	4	4	4	4	4	
M (Converter Count)	2	4	6	2	4	2	4	4	2	2	1	1	2	
F (Octets per Frame per Lane)	4	4	4	2	2	3	3	8	1	2	1	2	3	
S (Samples per Converter per Frame)	1	1	1	1	1	1	1	1	1	2	2	4	4	
NP (Total number of Bits per Sample)	16	16	16	16	16	12	12	16	16	16	16	16	12	
N (Converter Resolution)	16	16	16	16	16	12	12	16	16	16	16	16	12	

### Configuration Parameters

The AD9174 modes refer to the link configuration parameters for L, K, M, N, NP, S, and F. Table 30 provides the description and addresses for these settings.

**Table 30. Configuration Parameters**

JESD204B Setting	Description	Address
L – 1	Number of lanes minus 1.	Register 0x453, Bits[4:0]
F – 1	Number of ((octets per frame) per lane) minus 1.	Register 0x454, Bits[7:0]
K – 1	Number of frames per multiframe minus 1.	Register 0x455, Bits[4:0]
M – 1	Number of converters minus 1.	Register 0x456, Bits[7:0]
N – 1	Converter bit resolution minus 1.	Register 0x457, Bits[4:0]
NP – 1	Bit packing per sample minus 1.	Register 0x458, Bits[4:0]
S – 1	Number of ((samples per converter) per frame) minus 1.	Register 0x459, Bits[4:0]
HD	High density format. Set to 1.	Register 0x45A, Bit 7
DID	Device ID. Match the device ID sent by the transmitter.	Register 0x450, Bits[7:0]
BID	Bank ID. Match the bank ID sent by the transmitter.	Register 0x451, Bits[7:0]
LID0	Lane ID for Lane 0. Match the Lane ID sent by the transmitter on Logical Lane 0.	Register 0x452, Bits[4:0]
JESDV	JESD204x version. Match the version sent by the transmitter (0x0 = JESD204A, 0x1 = JESD204B).	Register 0x459, Bits[7:5]

The AD9174 truncates the output of the main digital datapath to the value of N bits for the selected mode, which is then sent to the DAC core. It is possible to send the value of NP number of bits worth of data with the lower NP – N LSBs padded as 0s, or to send the full NP number of bits data across the SERDES lanes. In either case, the lower NP – N LSBs are truncated prior to the DAC core.

### Data Flow Through the JESD204B Receiver

The link configuration parameters determine how the serial bits on the JESD204B receiver interface are deframed and passed on to the DACs as data samples.

### Deskewing and Enabling Logical Lanes

After proper configuration, the logical lanes are automatically deskewed. All logical lanes are enabled or not based on the number of lanes for the mode setting chosen in Register 0x110, Bits[4:0]. The physical lanes are all powered up by default. To disable power to physical lanes that are not being used, set Bit x in Register 0x201 to 1 to disable Physical Lane x, and keep it at 0 to enable it. The logical lanes must be enabled and deskewed on a per link basis using the LINK\_PAGE control (Register 0x300, Bit 2). Set Bit x in Register 0x46C to 1 to deskew Link Logical Lane x for the selected link page.

### JESD204B TEST MODES

#### PRBS Testing

The JESD204B receiver on the AD9174 includes a PRBS pattern checker on the back end of the PHY layer. The pattern checker supports PRBS7, PRBS15, and PRBS31 data patterns, as defined in the JESD204B specifications. The PRBS pattern can be sourced from an external JESD204B transmitter, such as a field-programmable gate array (FPGA), or alternatively generated by the internal PRBS7 generator as described in the Internal PRBS7 Generator section. This functionality allows testing of the bit error rate (BER) on each physical lane of the AD9174 as well as the JESD204B PHY as a whole. Low BER during PRBS testing confirms proper clocking and clock synchronization, and confirms that the interconnections (traces, connectors, and cabling) between the JESD204B transmitter and receiver is of sufficient quality. Although the PHY PRBS pattern checker does not require that the JESD204B link be fully established, the JESD204B mode on the AD9174 must be configured so that the physical lanes are properly clocked and are ready to receive PRBS data. The PRBS data must not be 8-bit/10-bit encoded. PRBS pattern verification can be performed on multiple lanes at once or on one lane at a time. The error count for each failing JESD204B lane is reported independently.

The process for enabling the PRBS checker on the AD9174 is as follows:

1. Start sending a PRBS7, PRBS15, or PRBS31 looped pattern, either from a JESD204B transmitter, or from the internal PRBS7 generator of the AD9174.
2. Select the appropriate PRBS pattern to be received by writing to Register 0x316, Bits[3:2], as shown in Table 31.
3. Enable the PHY test for all lanes being tested by writing to PHY\_TEST\_EN (Register 0x315). Each bit of Register 0x315 enables the PRBS test for the corresponding lane. For example, writing a 1 to Bit 0 enables the PRBS test for Physical Lane 0. Any running JESD204B link is interrupted at this point.
4. Toggle PHY\_TEST\_RESET (Register 0x316, Bit 0) from 0 to 1 then back to 0 to reset the status registers to the default value.
5. Set PHY\_PRBS\_TEST\_THRESHOLD\_xBITS (Register 0x319 to Register 0x317, Bits[23:0]) as desired.
6. Write a 0 and then a 1 to PHY\_TEST\_START (Register 0x316, Bit 1). The rising edge of PHY\_TEST\_START starts the test.
  - a. In some cases, it may be necessary to repeat Step 4 at this point. Toggle PHY\_TEST\_RESET (Register 0x316, Bit 0) from 0 to 1, then back to 0.
7. Wait to accumulate the desired number of bits, or at least 500 ms.
8. Stop the test by writing PHY\_TEST\_START (Register 0x316, Bit 1) = 0.

9. Read the PRBS test results from the PRBS status registers:
  - a. Each bit of PHY\_PRBS\_PASS (Register 0x31D) corresponds to one SERDES lane (0 = fail, 1 = pass). The default value following a reset is pass. To confirm that the reported results are not a false positive, force a fail condition on one or all of the lanes before running a lengthy BER test. Either temporarily disable some or all of the lanes for which the test was previously enabled and confirm that the test fails, or select a PRBS pattern of the incorrect type in Step 2 to observe failures on all lanes. Then, reconfigure the test appropriately and run the test to accumulate BER results.
  - b. The number of PRBS errors seen on each failing lane can be read by writing the lane number to check (0 to 7) in PHY\_SRC\_ERR\_CNT (Register 0x316, Bits[6:4]) and reading the PHY\_PRBS\_ERR\_CNT\_xBITS (Register 0x31A to Register 0x31C). The maximum error count is  $2^{24-1}$ . If all bits of Register 0x31A to Register 0x31C are high, the maximum error count on the selected lane is exceeded.

**Table 31. PHY PRBS Pattern Selection**

PHY_PRBS_PAT_SEL Setting (Register 0x316, Bits[3:2])	PRBS Pattern
0b00 (default)	PRBS7
0b01	PRBS15
0b10	PRBS31

### Internal PRBS7 Generator

The AD9174 integrates one internal PRBS7 generator that can be used to test the JESD204B PHYs without an external PRBS data input from a JESD204B transmitter. Although this approach only confirms the portion of the PHY internal to the AD9174, it does confirm that both the PRBS checker and internal clock domains are running and are configured correctly. The internal PRBS test is ideally followed by a more thorough, external PHY PRBS test, in which case the pattern is sourced by a JESD204B transmitter device.

The process for configuring the internal PRBS7 generator on the AD9174 is as follows:

1. Set the EQ\_BOOST\_PHYx bits (Register 0x240, Bits[7:0] and Register 0x241, Bit[7:0]) to 0.
  2. Set SEL\_IF\_PARDATAINV\_DES\_RC\_CH bits (Register 0x234, Bits[7:0]) to 0 to make sure lanes not inverted.
  3. Enable the loop back test for all lanes being tested by writing to EN\_LBT\_DES\_RC\_CH (Register 0x250). Each bit of Register 0x250 enables the loop back test for the corresponding lane. For example, writing a 1 to Bit 0 enables the test for Physical Lane 0.
  4. For halfrate, set EN\_LBT\_HALFRATE\_DES\_RC (Register 0x251, Bit 1) to 1. Otherwise, set this bit to 0.
  5. Toggle INIT\_LBT\_SYNC\_DES\_RC (Register 0x251, Bit 0) from 0 to 1 then back to 0.
6. Refer to the PRBS Testing section for information on how to configure the PRBS checker for a PRBS7 test.

### Transport Layer Testing

The JESD204B receiver in the AD9174 supports the short transport layer (STPL) test as described in the JESD204B standard. Use this test to verify the data mapping between the JESD204B transmitter and receiver. To perform this test, this function must be implemented and enabled in the logic device. Before running the test on the receiver side, the link must be established and running without errors.

The STPL test ensures that each sample from each converter is mapped appropriately according to the number of converters (M) and the number of samples per converter (S). As specified in the JESD204B standard, the converter manufacturer specifies the test samples that are transmitted. Each sample must have a unique value. For example, if  $M = 2$  and  $S = 2$ , four unique samples are transmitted repeatedly until the test is stopped. The expected sample must be programmed into the device and the expected sample is compared to the received sample one sample at a time until all are tested. The process for performing this test on the AD9174 is described as follows:

1. Synchronize and establish a JESD204B link between the transmitter and the AD9174.
2. Enable the STPL test at the JESD204B transmitter. Depending on JESD204B mode, there may be up to six data streams per link, to feed up to three complex sub-channels ( $M = 6$ ), and each frame can contain up to eight samples ( $S = 8$ ).
3. Configure the SHORT\_TPL\_REF\_SP\_MSB bits (Register 0x32E) and the SHORT\_TPL\_REF\_SP\_LSB bits (Register 0x32D) to match one of the samples within a single frame. For  $N = 12$  modes, the integer value of the expected sample is multiplied by 16 (binary, 4-bit shift operation).
4. If testing a dual-link JESD204B, set SHORT\_TPL\_LINK\_SEL (Register 0x32F, Bit 7) to select whether Link 0 (DAC0 datapath(s)) or Link 1 (DAC1 datapath(s)) is tested.
5. Set SHORT\_TPL\_CHAN\_SEL (Register 0x32C, Bits[3:2]) to select the channel.
6. Set SHORT\_TPL\_IQ\_PATH\_SEL (Register 0x32F, Bit 6) to select the I or Q stream of the channel under test.
7. Set SHORT\_TPL\_SP\_SEL (Register 0x32C, Bits[7:4]) to select which sample within each frame is expected to have the value indicated in Step 3.
8. Set SHORT\_TPL\_TEST\_EN (Register 0x32C, Bit 0) to 1.
9. Set SHORT\_TPL\_TEST\_RESET (Register 0x32C, Bit 1) to 1, then back to 0.
10. Wait for the desired time. The desired time is calculated as  $1/(\text{sample rate} \times \text{BER})$ . For example, given  $\text{BER} = 1 \times 10^{-10}$  and a sample rate = 1 GSPS, the desired time = 10 sec.
11. Read the test result at SHORT\_TPL\_FAIL (Register 0x32F, Bit 0).

- Choose another sample for the same or another M to continue with the test, until all samples for both converters from one frame are verified.

### Repeated CGS and ILAS Test

As per Section 5.3.3.8.2 of the JESD204B specification, the AD9174 can check that a constant stream of /K28.5/ characters is being received, or that CGS followed by a constant stream of ILAS is being received.

To run a repeated CGS test, send a constant stream of /K28.5/ characters to the AD9174 SERDES inputs. Next, set up the device and enable the links. Ensure that the /K28.5/ characters are being received by verifying that SYNCOUT± is deasserted and that CGS has passed for all enabled link lanes by reading Register 0x470.

To run the CGS followed by a repeated ILAS sequence test, follow the procedure to set up the links, but before performing the last write (enabling the links), enable the ILAS test mode by writing a 1 to Register 0x477, Bit 7. Then, enable the links. When the device recognizes four CGS characters on each lane, it deasserts the SYNCOUT±. At this point, the transmitter starts sending a repeated ILAS sequence.

Read Register 0x473 to verify that the initial lane synchronization has passed for all enabled link lanes.

## JESD204B ERROR MONITORING

### Disparity, Not in Table, and Unexpected Control (K) Character Errors

As per Section 7.6 of the JESD204B specification, the AD9174 can detect disparity errors, not in table (NIT) errors, and unexpected control character errors, and can optionally issue a sync request and reinitialize the link when errors occur.

Several other interpretations of the JESD204B specification are noted in this section. When three NIT errors are injected to one lane and QUAL\_RDERR (Register 0x476, Bit 4) = 1, the readback values of the bad disparity error (BDE) count register is 1.

Reporting of disparity errors that occur at the same character position of an NIT error is disabled. No such disabling is performed for the disparity errors in the characters after an NIT error. Therefore, it is expected behavior that an NIT error may result in a BDE error.

### Checking Error Counts

The error count can be checked for disparity errors, NIT errors, and unexpected control character errors. The error counts are on a per lane and per error type basis. Each error type and lane has a register dedicated to it. To check the error count, the following steps must be performed:

- Choose and enable which errors to monitor by selecting them in Register 0x480, Bits[5:3] to Register 0x487, Bits[5:3]. Unexpected K (UEK) character, BDE, and NIT error monitoring can be selected for each lane by writing a 1 to

the appropriate bit, as described in Table 62. These bits are enabled by default.

- The corresponding error counter reset bits are in Register 0x480, Bits[2:0] to Register 0x487, Bits[2:0]. Write a 1 to the corresponding bit to reset that error counter.
- Registers 0x488, Bits[2:0] to Register 0x48F, Bits[2:0] have the terminal count hold indicator for each error counter. If this flag is enabled, when the terminal error count of 0xFF is reached, the counter ceases counting and holds that value until reset. Otherwise, it wraps to 0x00 and continues counting. Select the desired behavior and program the corresponding register bits per lane.

### Check for Error Count Over Threshold

To check for the error count over threshold, follow these steps:

- Define the error counter threshold. The error counter threshold can be set to a user defined value in Register 0x47C, or left to the default value of 0xFF. When the error threshold is reached, an IRQ is generated, SYNCOUT± is asserted, or both, depending on the mask register settings. This one error threshold is used for all three types of errors (UEK, NIT, and BDE).
- Set the SYNC\_ASSERT\_MASK bits. The SYNCOUT± assertion behavior is set in Register 0x47D, Bits[2:0]. By default, when any error counter of any lane is equal to the threshold, it asserts SYNCOUT± (Register 0x47D, Bits[2:0] = 0b111). When setting the SYNC\_ASSERT\_MASK bits, LINK\_PAGE (Register 0x300, Bit 2) must be set to 1.
- Read the error count reached indicator. Each error counter has a terminal count reached indicator, per lane. This indicator is set to 1 when the terminal count of an error counter for a particular lane is reached. These status bits are located in Register 0x490, Bits[2:0] to Register 0x497, Bits[2:0]. Bit 3 can be read back to indicate whether a particular lane is active.

### Error Counter and IRQ Control

For error counter and IRQ control, follow these steps:

- Enable the interrupts. Enable the JESD204B interrupts. The interrupts for the UEK, NIT, and BDE error counters are in Register 0x4B8, Bits[7:5]. There are other interrupts to monitor when bringing up the link, such as lane deskewing, initial lane sync, good check sum, frame sync, code group sync (Register 0x4B8, Bits[4:0]), and configuration mismatch (Register 0x4B9, Bit 0). These bits are off by default but can be enabled by writing 0b1 to the corresponding bit.
- Read the JESD204B interrupt status. The interrupt status bits are in Register 0x4BA, Bits[7:0] and Register 0x4BB, Bit 0, with the status bit position corresponding to the enable bit position.

- It is recommended to enable all interrupts that are planned to be used prior to bringing up the JESD204B link. When the link is up, the interrupts can be reset and then used to monitor the link status.

### Monitoring Errors via SYNCOUTx±

When one or more disparity, NIT, or unexpected control character errors occur, the error is reported on the SYNCOUTx± pin as per Section 7.6 of the JESD204B specification. The JESD204B specification states that the SYNCOUTx± signal is asserted for exactly two frame periods when an error occurs. For the AD9174, the width of the SYNCOUTx± pulse can be programmed to ½, 1, or 2 PCLK cycles. The settings to achieve a SYNCOUTx± pulse of two frame clock cycles are given in Table 32.

**Table 32. Setting SYNCOUTx± Error Pulse Duration**

F	PCLK Factor (Frames/PCLK)	SYNC_ERR_DUR (Register 0x312, Bits[7:4]) Setting <sup>1</sup>
1	4	0 (default)
2	2	1
3	1.5	2
4	1	2
8	0.5	4

<sup>1</sup> These register settings assert the SYNCOUTx± signal for two frame clock cycle pulse widths.

### Unexpected Control Character, NIT, Disparity IRQs

For UEK character, NIT, and disparity errors, error count over the threshold events are available as IRQ events. Enable these events by writing to Register 0x4B8, Bits[7:5]. The IRQ event status can be read at Register 0x4BA, Bits[7:5] after the IRQs are enabled.

See the Error Counter and IRQ Control section for information on resetting the IRQ. See the Interrupt Request Operation section for more information on IRQs.

### Errors Requiring Reinitializing

A link reinitialization automatically occurs when four invalid disparity characters or four NIT characters are received as per Section 7.1 of the JESD204B specification. When a link reinitialization occurs, the resync request is at least five frames and nine octets long.

The user can optionally reinitialize the link when the error count for disparity errors, NIT errors, or UEK character errors reaches a programmable error threshold. The process to enable the reinitialization feature for certain error types is as follows:

- Choose and enable which errors to monitor by selecting them in Register 0x480, Bits[5:3] to Register 0x487, Bits[5:3]. UEK, BDE, and NIT error monitoring can be selected for each lane by writing a 1 to the appropriate bit, as described in Table 33. These are enabled by default.
- Write a 0 to the corresponding bit to Register 0x480, Bits[2:0] to Register 0x487, Bits[2:0] to take counter out of reset.

- Enable the sync assertion mask for each type of error by writing to SYNC\_ASSERT\_MASK (Register 0x47D, Bits[2:0]) according to Table 33.
- Program the desired error counter threshold into ERRORTHRES (Register 0x47C).
- For each error type enabled in the SYNC\_ASSERT\_MASK register, if the error counter on any lane reaches the programmed threshold, SYNCOUTx± falls, issuing a sync request. All error counts are reset when a link reinitialization occurs. The IRQ does not reset and must be reset manually.

**Table 33. Sync Assertion Mask (SYNC\_ASSERT\_MASK)**

Addr.	Bit No.	Bit Name	Description
0x47D	2	BDE	Set to 1 to assert SYNCOUTx± if the disparity error count reaches the threshold
	1	NIT	Set to 1 to assert SYNCOUTx± if the NIT error count reaches the threshold
	0	UEK	Set to 1 to assert SYNCOUTx± if the UEK character error count reaches the threshold

### CGS, Frame Sync, Checksum, and ILAS Monitoring

Register 0x470 to Register 0x473 can be monitored to verify that each stage of the JESD204B link establishment has occurred.

Bit x of CODE\_GRP\_SYNC (Register 0x470) is high if Link Lane x received at least four K28.5 characters and passed code group synchronization.

Bit x of FRAME\_SYNC (Register 0x471) is high if Link Lane x completed initial frame synchronization.

Bit x of GOOD\_CHECKSUM (Register 0x472) is high if the checksum sent over the lane matches the sum of the JESD204B parameters sent over the lane during ILAS for Link Lane x. The parameters can be added either by summing the individual fields in registers or summing the packed register. The calculated checksums are the lower eight bits of the sum of the following fields: DID, BID, LID, SCR, L – 1, F – 1, K – 1, M – 1, N – 1, SUBCLASSV, NP – 1, JESDV, S – 1, and HD.

Bit x of INIT\_LANE\_SYNC (Register 0x473) is high if Link Lane x passed the initial lane alignment sequence.

### CGS, Frame Sync, Checksum, and ILAS IRQs

Fail signals for CGS, frame sync, checksum, and ILAS are available as IRQ events. Enable them by writing to Register 0x4B8, Bits[3:0]. The IRQ event status can be read at Register 0x4BA, Bits[3:0] after the IRQs are enabled. Write a 1 to Register 0x4BA, Bit 0 to reset the CGS IRQ. Write a 1 to Register 0x4BA, Bit 1 to reset the frame sync IRQ. Write a 1 to Register 0x4BA, Bit 2 to reset the checksum IRQ. Write a 1 to Register 0x4BA, Bit 3 to reset the ILAS IRQ.

See the Interrupt Request Operation section for more information.

### Configuration Mismatch IRQ

The AD9174 has a configuration mismatch flag that is available as an IRQ event. Use Register 0x4B9, Bit 0 to enable the mismatch flag (it is enabled by default), and then use Register 0x4BB, Bit 0 to read back its status and reset the IRQ signal. See the Interrupt Request Operation section for more information.

The configuration mismatch event flag is high when the link configuration settings (in Register 0x450 to Register 0x45D) do not match the JESD204B settings received by the device (Register 0x400 to Register 0x40D).

This function is different from the good checksum flags in Register 0x472. The good checksum flags ensure that the transmitted checksum matches a calculated checksum based on the transmitted settings. The configuration mismatch event ensures that the transmitted settings match the configured settings.

## DIGITAL DATAPATH

The AD9174 has two independent digital datapaths, each typically supplying data samples to the respective DACx core. However, there are modulator switch configurations that allow additional ways to route the samples to either DAC0, DAC1, or both DACs. See the Modulator Switch section for more details.

Each digital datapath consists of multiple channel datapaths (channelizers) that sum into a single datapath (main datapath), which in turn connects to its respective DAC core by default (see Figure 1). The channelizers and the main datapaths are fully bypassable, depending on the JESD204B mode selected by the user. There are a variety of digital processing blocks available within the channelizers and the main datapaths, including interpolation filters, bypassable NCOs that allow either digital I/Q modulation of samples or standalone (DDS) operation, PA protection blocks (power detection and protection (PDP) block), and digital gain blocks to ramp or set the sample gain.

### TOTAL DATAPATH INTERPOLATION

The AD9174 contains two stages of interpolation filters: one stage is located within each channel datapath and is set to a single value across all channels, and one stage is located within each main datapath. The total interpolation for a complete digital datapath can be determined by multiplying the channel interpolation factor by the main datapath interpolation factor. The relationship between the DAC sample rate and input data rate is shown in the following equation:

$$\text{Total Interpolation} = \text{Channel Interpolation} \times \text{Main Interpolation}$$

$$f_{\text{DATA}} = f_{\text{DAC}} / (\text{Channel Interpolation} \times \text{Main Interpolation})$$

Each of the various cascaded half-band interpolation filters covers 80% of the total bandwidth (BW) occupied by the incoming data. Therefore, if using interpolation (total interpolation > 1), the available signal BW is 80% of the data rate. If the interpolation stages are bypassed (total interpolation = 1), the available signal BW is 50% of the data rate because complex data is not used.

The signal bandwidth is calculated as follows:

$$\text{Signal BW} = 0.8 \times f_{\text{DATA}}, \text{ if total interpolation} > 1$$

$$\text{Signal BW} = 0.5 \times f_{\text{DATA}}, \text{ if total interpolation} = 1$$

The interpolation values are programmed as shown in the Table 34.

Table 34. Interpolation Factor Register Settings

Interpolation Factor	Main Datapath, Register 0x111, Bits[7:4]	Channel Datapath, Register 0x111, Bits[3:0]
1x	0x1	0x1
2x	0x2	0x2
3x	Not applicable	0x3
4x	0x4	0x4
6x	0x6	0x6
8x	0x8	0x8
12x	0xC	Not applicable

Table 35. Interpolation Modes and Useable Bandwidth

Total Interpolation	Available Signal Bandwidth	f <sub>DATA</sub>
1x (Bypass)	0.5 × f <sub>DATA</sub>	f <sub>DAC</sub>
2x, 4x, 6x, 8x, 12x, 16x, 18x, 24x, 32x, 36x, 48x, 64x	0.8 × f <sub>DATA</sub>	f <sub>DAC</sub> /total interpolation

### Filter Performance

The interpolation filters interpolate the incoming data samples so that changes in the incoming data are minimized, while suppressing any interpolation images.

The usable bandwidth, as shown in Table 35, is defined as the frequency band over which the filters have a pass-band ripple of less than ±0.001 dB and an image rejection of greater than 85 dB. Conceptual drawings that shows the relative bandwidth of each of the filters are shown in Figure 70 and Figure 71. The maximum pass-band amplitude of all filters is the same. In Figure 70 and Figure 71, the amplitudes are intentionally shown to be different to improve understanding, and in reality the amplitude across all filters is constant and uniform regardless of the interpolation rate selected by the user.

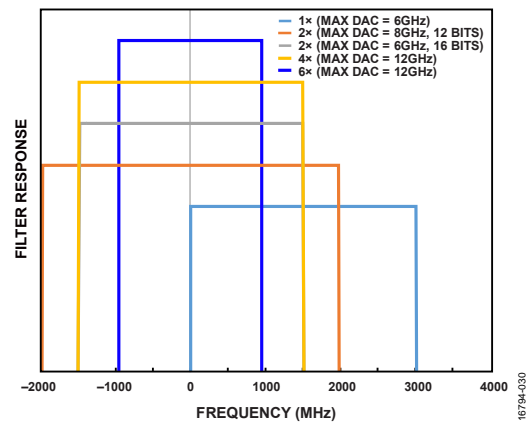

Figure 70. Band Responses of Total Interpolation Rates for 1x, 2x, 4x, and 6x at Each Respective Maximum Achievable DAC Rate and Resolution

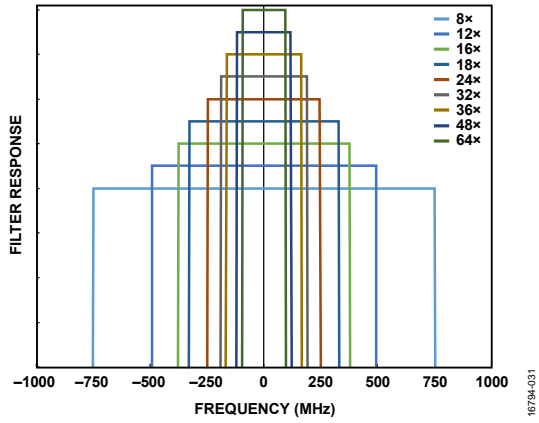

Figure 71. Band Responses of Total Interpolation Rates for 8x, 12x, 16x, 18x, 24x, 32x, 36x, 48x, and 64x at a 12 GHz DAC Rate

**CHANNEL DIGITAL DATAPATH**

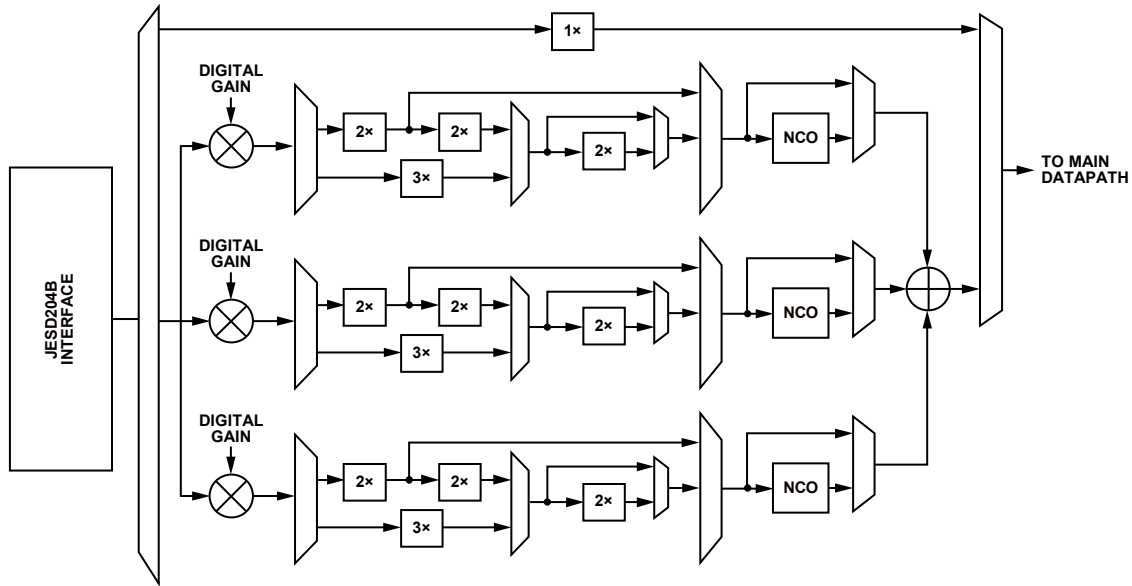

Figure 72. Block Diagram of the Channel Digital Datapath per the Main DAC Output

Whether one or all of the channelizers in each datapath are enabled is defined by the JESD204B mode selected by the user. Each channelizer consists of a digital gain stage, complex interpolation block, and a complex 48-bit modulus NCO. The channelizers and the summing node can be fully bypassed (1× interpolation selected). The interpolation rate selection is applied to all channelizers and cannot be independently controlled. However, the gain stage and complex NCO settings can all be controlled independently. The controls for these blocks are paged by the channel paging mask in the CHANNEL\_PAGE bits (Register 0x008, Bits[5:0]), as described in Table 36. Each bit of the page mask corresponds to a channel datapath. The channelizers can be either paged individually to apply settings that are unique to a specific channel, or can be paged as a group to address multiple channelizers using a single set of SPI writes.

**Table 36. Channel Page Mask**

CHANNEL_PAGE (Register 0x008, Bits[5:0])	Channel Paged	Channel Datapath Updated
0x01 (Bit 0)	Channel 0	Channel 0 of DAC0
0x02 (Bit 1)	Channel 1	Channel 1 of DAC0
0x04 (Bit 2)	Channel 2	Channel 2 of DAC0
0x08 (Bit 3)	Channel 3	Channel 0 of DAC1
0x10 (Bit 4)	Channel 4	Channel 1 of DAC1
0x20 (Bit 5)	Channel 5	Channel 2 of DAC1

Each of the digital blocks in the channels is described in more detail in the following sections.

**Digital Gain**

Each channelizer has an independent gain control that allows unique gain scaling for each complex data stream. The gain code for each channel is 12-bit resolution, located in Register 0x146 and Register 0x147, and can be calculated by the following formulas:

$$0 \leq \text{Gain} \leq (2^{12} - 1)/2^{11}$$

$$-\infty \text{ dB} < \text{dB Gain} \leq +6.018 \text{ dB}$$

$$\text{Gain} = \text{Gain Code} \times (1/2048)$$

$$\text{dB Gain} = 20 \times \log_{10}(\text{Gain})$$

$$\text{Gain Code} = 2048 \times \text{Gain} = 2^{11} \times 10^{(\text{dB Gain}/20)}$$

The gain code control (CHNL\_GAIN) is paged with the channel page mask (CHANNEL\_PAGE) in Register 0x008, Bits[5:0].

Because the output of all three channels is summed ahead of the main datapath, take extra care when setting the gain to avoid sample clipping if the combined amplitude exceeds full scale after being summed. For example, if all three channels are used and all three data streams contain samples that are >1/3 full scale, clipping may occur. In other words, at any specific point in time, the sum of the samples at the output of all enabled channels must be between  $-2^{15}$  and  $(2^{15} - 1)$ .

The digital gain feature is available in all JESD204B modes, except when 1× channel interpolation is used because the channel digital processing features are bypassed in that mode, as shown in Figure 73.

### Channel Interpolation

The channel interpolation options available are bypass (1×), 2×, 3×, 4×, 6×, and 8×. Each of the half-band filters used for interpolation has up to 80% bandwidths with 85 dB of stop band rejection. The channel half-band cascaded configuration is shown in Figure 73, with each of the useable bandwidths of the channel interpolation filters listed in Table 37.

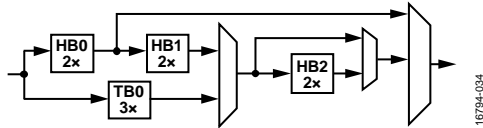

Figure 73. Channel Interpolation Half-Band Filter Block Diagram

Table 37. Channel Interpolation Useable Bandwidths and Rejection

Half-Band Filter	Bandwidth ( $\times f_{\text{IN\_FILTER}}^1$ ) (%)	Stop Band Rejection (dB)
HB0	80	85
TB0	54	85
HB1	40	85
HB2	27	85

<sup>1</sup>  $f_{\text{IN\_FILTER}}$  is the frequency at the input of the half-band filter.

### Channel Digital Modulation

Each channelizer includes a 48-bit dual-modulus NCO to allow I/Q modulation of each channel data to an independent carrier frequency, each with its own phase offset control. The 48-bit NCO can be configured into either integer or modulus (DDS) mode. In modulus mode, the A/B ratio added to the integer FTW of the NCO allows the frequency to be synthesized with near infinite precision. See the 48-Bit Integer/Modulus NCO section for more details. NCO mode is selected as shown in Table 38. These controls are paged per the channel page masks in the CHANNEL\_PAGE bits (Register 0x008, Bits[5:0]).

Table 38. Channel Modulation Mode Selection

Modulation Mode	Modulation Type	
	Register 0x130, Bit 6	Register 0x130, Bit 2
None	0b0	0b0
48-Bit Integer NCO	0b1	0b0
48-Bit Dual Modulus NCO	0b1	0b1

The channel NCO blocks also contain sideband selection controls as well as options for how the FTW and phase offset controls are updated. The phase offset word control can be calculated as follows:

$$-180^\circ \leq \text{Degrees Offset} \leq +180^\circ$$

$$\text{Degrees Offset} = 180^\circ \times (\text{DDSC\_NCO\_PHASE\_OFFSET}/2^{15})$$

where DDSC\_NCO\_PHASE\_OFFSET is a 16-bit twos complement value programmed in the registers listed in Table 39.

Table 39. Channel NCO Phase Offset Registers

Address	Value	Description
0x138	DDSC_NCO_PHASE_OFFSET[7:0]	8 LSBs of phase offset
0x139	DDSC_NCO_PHASE_OFFSET[15:8]	8 MSBs of phase offset

### 48-Bit Integer/Modulus NCO

The 48-bit integer/modulus NCO combines an NCO block, a phase shifter, and a complex modulator to modulate the signal onto a user defined carrier frequency, as shown in Figure 74. This configuration allows output signals to be shifted anywhere across the output spectrum up to  $\pm f_{\text{NCO}}/2$  with very fine frequency resolution.

The NCO produces a quadrature carrier to translate the input signal to a new center frequency. A quadrature carrier is a pair of sinusoidal waveforms of the same frequency, offset 90° from each other. The frequency of the quadrature carrier is set using the FTW. The quadrature carrier is mixed with the I and Q data and then summed into the I and Q datapaths, as shown in Figure 74.

Each of the channel 48-bit NCOs can be configured to run in integer mode (that is, when only the FTW value defines the NCO output frequency). The value of the FTW in part depends on the clock speed at which the NCO block is running ( $f_{\text{NCO,CLK}}$ ). For any channel NCO, the clock rate is equal to the rate of the summing node (maximum of 1.575 GSps) and can be calculated by using the following formulas:

$$f_{\text{NCO,CLK}} = f_{\text{DATA}} \times \text{Channel Interpolation}$$

or

$$f_{\text{NCO,CLK}} = f_{\text{DAC/Main Interpolation}} = f_{\text{SUMMING\_NODE}}$$

The FTWs for each individual NCO can be programmed separately and are calculated by using the following formula:

$$-f_{\text{NCO,CLK}}/2 \leq f_{\text{CARRIER}} < +f_{\text{NCO,CLK}}/2$$

$$\text{DDSC\_FTW} = (f_{\text{CARRIER}}/f_{\text{NCO,CLK}}) \times 2^{48}$$

where:

DDSC\_FTW is a 48-bit, twos complement number.

$f_{\text{CARRIER}}$  is the output frequency of the NCO.

$f_{\text{NCO,CLK}}$  is the sampling clock frequency of the NCO.

The frequency tuning word is set as shown in Table 40.

Table 40. Channel NCO FTW Registers

Address	Value	Description
0x132	DDSC_FTW[7:0]	8 LSBs of FTW
0x133	DDSC_FTW[15:8]	Next eight bits of FTW
0x134	DDSC_FTW[23:16]	Next eight bits of FTW
0x135	DDSC_FTW[31:24]	Next eight bits of FTW
0x136	DDSC_FTW[39:32]	Next eight bits of FTW
0x137	DDSC_FTW[47:40]	8 MSBs of FTW

Unlike other NCO control registers, the FTW registers are not applied to the NCO block immediately upon writing the control register. Instead, the FTW registers are applied on the rising edge of DDSC\_FTW\_LOAD\_REQ (Register 0x131, Bit 0). After an update request, DDSC\_FTW\_LOAD\_ACK (Register 0x131, Bit 1) must indicate a status high to acknowledge that the FTW has been updated.

The DDSC\_SEL\_SIDE BAND bit (Register 0x130, Bit 1 = 0b1) is a convenience bit that controls whether the lower- or upper-sideband of the modulated data is used, which is equivalent to flipping the sign of the FTW.

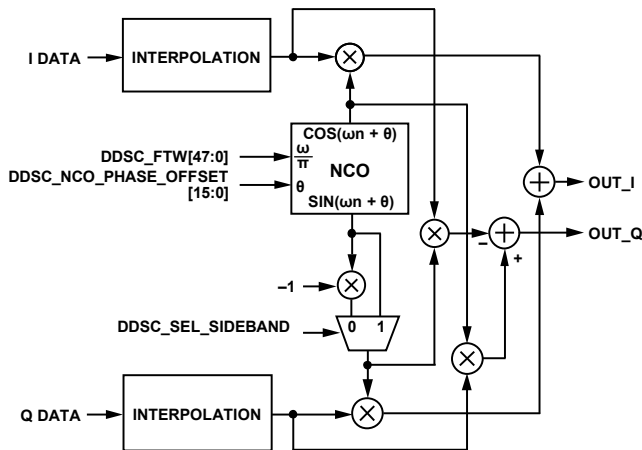

Figure 74. NCO Modulator Block Diagram

### Channel Modulus NCO Mode (Direct Digital Synthesis (DDS) Mode)

Each 48-bit channel NCO can also be used in a dual modulus mode to create fractional frequencies beyond the 48-bit accuracy that integer mode provides, which may be of interest in applications where the NCO is running for prolonged periods of time without being reset, thus possibly resulting in a noticeable phase drift relative to other clocks in the system, even given the small initial frequency error of the 48-bit, integer NCO. The modulus mode is enabled by programming the DDSC\_MODULUS\_EN bit in the DDSC\_DATAPATH\_CFG register to 1 (Register 0x130, Bit 2 = 0b1).

The frequency ratio for the programmable modulus DDS is very similar to that of the typical accumulator-based DDS. The only difference is that N is not required to be a power of two (as for integer NCOs) for the programmable modulus, but can be an arbitrary integer. In practice, hardware constraints place limits on the range of values for N. As a result, the modulus extends the use of the NCO to applications that require exact rational frequency synthesis. The underlying function of the programmable modulus technique is to alter the accumulator modulus.

Implementation of the programmable modulus function within the AD9174 is such that the fraction,  $M/N$ , is expressible by the following equation. The form of the equation implies a compound frequency tuning word with X representing the integer part and A/B representing the fractional part.

$$\frac{f_{CARRIER}}{f_{NCO,CLK}} = \frac{M}{N} = \frac{X + \frac{A}{B}}{2^{48}}$$

where:

X is the FTW, programmed in Register 0x132 to Register 0x137.

A is programmed in Register 0x140 to Register 0x145.

B is programmed in Register 0x13A to Register 0x13F.

Because X, A, and B are 48-bit words, modulus mode allows the user to set the NCO output frequency ( $f_{CARRIER}$ ) with a precision of  $(f_{NCO,CLK})/2^{(2 \times 48)}$ .

### Programmable Modulus Example

Consider the case in which  $f_{NCO,CLK} = 1500$  MHz and the desired value of  $f_{CARRIER}$  is 150 MHz. This scenario synthesizes an output frequency that is not a power of two submultiple of the sample rate, namely  $f_{CARRIER} = (1/10) f_{NCO,CLK}$ , which is not possible with a typical accumulator-based DDS. The frequency ratio,  $f_{CARRIER}/f_{NCO,CLK}$ , leads directly to M and N, which are determined by reducing the fraction (150,000,000/1,500,000,000) to its lowest terms, that is,

$$M/N = 150,000,000/1,500,000,000 = 1/10$$

Therefore,  $M = 1$  and  $N = 10$ .

After calculation,  $X = 28,147,497,671,065$ ,  $A = 3$ , and  $B = 5$ . Programming these values into the registers for X, A, and B (X is programmed in Register 0x132 to Register 0x137 for DDSC\_FTWSx, B is programmed in Register 0x13A to Register 0x13F for DDSC\_ACC\_MODULUSx, and A is programmed in Register 0x140 to Register 0x145 for DDSC\_ACC\_DELTAx) causes the NCO to produce an output frequency of exactly 150 MHz given a 1500 MHz sampling clock. For more details, refer to the [AN-953 Application Note](#).

### NCO Reset

Resetting an NCO is useful when determining the start time and phase of a particular NCO. Each Channel NCO can be configured to reset in response to one of several events: a direct request via SPI (Register 0x131, Bit 0), a change to one of the FTW register values, or on the next SYSREF± rising edge. The reset method is controlled by Register 0x131. See the detailed description for Register 0x131 for more information.

### Channel Summing Node

The outputs of the channelizers are combined at the summing node junction before being routed to the respective main datapath. The summation of any number of channels being used must not exceed a value range of  $\pm 2^{15}$  to avoid clipping (binary overflow) of the 16-bit data samples that are summed into the main datapath. The maximum data rate for each channel when the channel interpolation is  $>1\times$  is limited by the maximum speed of summing node junction, namely 1.575 GSPS. If the channel datapaths are bypassed (channel interpolation is  $1\times$ ), the summing node block is also bypassed, as shown in Figure 72. Bypassing the channelizer(s) allows passing data to the main digital datapath at a higher data rate. See Table 13 for JESD204B modes and the corresponding maximum data rates.

## MAIN DIGITAL DATAPATH

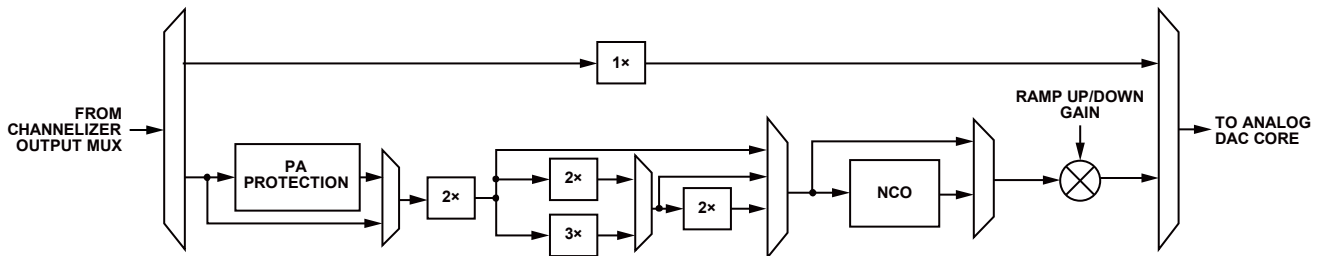

Figure 75. Block Diagram of the Main Digital Datapath per Main DAC Output

16794-036

Each main digital datapath consists of a power amplifier (PA) protection block, a set of complex interpolation filters, a 48-bit complex main datapath NCO, and a ramp-up/ramp-down gain stage. The main datapaths are bypassable (1× interpolation selected), which bypasses all the digital processing blocks included in the main datapath. The interpolation selection is set to the same value for all main datapaths and cannot be independently controlled. However, the PA protection block, complex NCO settings, and gain ramp can all be configured independently.

The controls for these blocks are paged by the main DAC datapath paging mask, MAINDAC\_PAGE (Register 0x008, Bits[7:6]), as listed in Table 41. Each bit of the page mask corresponds to a main DAC datapath. The datapaths can be either paged individually to apply settings that are unique to a specific main datapath, or can be paged as a group to address both datapaths using a single set of SPI writes.

Table 41. Main DAC Datapath Page Mask

MAINDAC_PAGE (Register 0x008, Bits[7:6])	DAC Paged	DAC Datapath Updated
0x40 (Bit 6)	DAC0	DAC0
0x80 (Bit 7)	DAC1	DAC1

Each digital block in the main datapath is described in more detail in the following sections.

**Downstream Protection (PA Protection)**

The AD9174 has several circuits designed to quickly reduce (or squelch) the amplitude of the samples that are to arrive at either DAC core, and thus protect PAs or other external system components located downstream from the AD9174 outputs. The DACx outputs can be either gradually ramped up or ramped down, or turned on or off in response to the following trigger signals, as shown in Figure 76:

- PDP\_PROTECT. This signal asserts when the calculated digital sample amplitude exceeds a programmable threshold.
- INTERFACE\_PROTECT. This signal asserts when specific JESD204B errors occur.
- SPI\_PROTECT. This signal asserts when the user writes the SPI control register directly.
- BSM\_PROTECT. This signal triggers the blanking state machine (BSM) module, which flushes the datapath on the rising edge of the TXEN0 or TXEN1 signal, which may come from a SPI write or the external TXEN0 or TXEN1 pin.

A number of flags are raised in response to the trigger events, that can also be routed to the IRQx I/O pins (IRQ0 and IRQ1), to possibly shut down other external downstream components or simply serve as indicators.

The DAC output on/off feature is similarly implemented through a feedforward trigger signal to the ramp-up/ramp-down digital gain block at the end of the main datapath before the analog DAC core, which allows the DAC to be turned on or off gradually (or quickly).

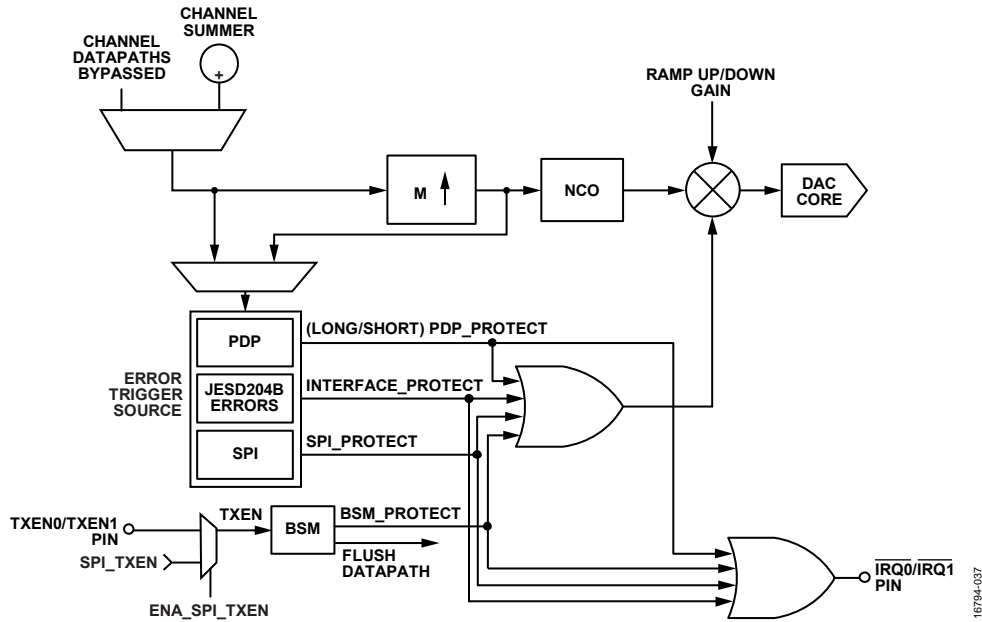

Figure 76. Block Diagram of Downstream Protection Triggers

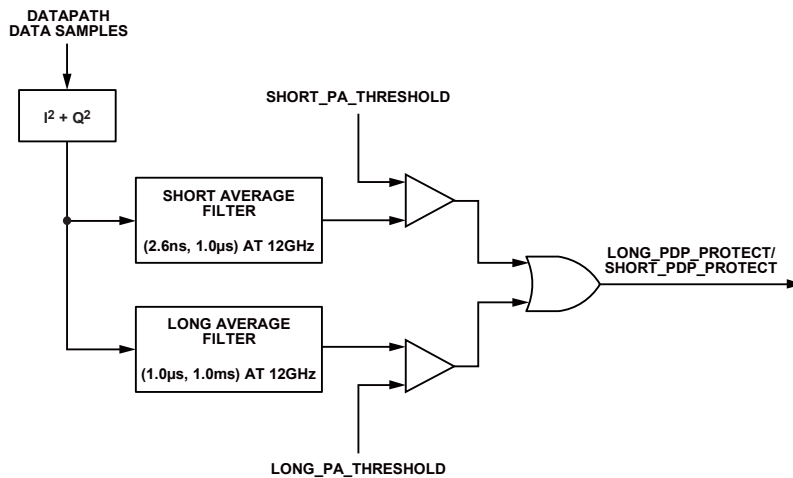

Figure 77. PDP Block Diagram

**Power Detection and Protection (PDP) Block**

The PDP block calculates the anticipated average power at the DACx core output and prevents overrange signals from being output from the AD9174, to avoid a potentially destructive breakdown of power sensitive devices, such as PAs. The protection block provides a signal, PDP\_PROTECT, that can be used ramp down the DAC output and/or be routed to an I/O pin to flag external components to shut down.

The PDP block uses a separate path with a shorter latency than the datapath to ensure that PDP\_PROTECT is triggered before the overrange signal reaches the analog DAC cores (with the exception when the total interpolation is 1x). The sum of I<sup>2</sup> and Q<sup>2</sup> are calculated as a representation of the input signal power (to improve response time, only the top six MSBs of data samples are used). The calculated sample power values are accumulated through a moving average filter with an output that is the average of the input signal power across a certain

number of samples. There are two types of average filters with different lengths: a short filter that detects high power pulses that may result in voltage breakdown, and a long filter that detects sustained high power signals that may last longer than the thermal constant of the PA or another device.

When the output of the averaging filter is larger than the threshold, the internal signal, PDP\_PROTECT, goes high, which can optionally be configured to trigger an IRQ flag and turn off the DAC output through the ramp-up/ramp-down.

The PDP block function is illustrated in Figure 77.

The long and short averaging times are configured by the LONG\_PA\_AVG\_TIME (Register 0x585, Bits[3:0]) and the SHORT\_PA\_AVG\_TIME (Register 0x58A, Bits[1:0]) controls. Use the following calculations to determine the average window size times:

$$\text{Length of Long Average Window} = 2^{\text{LONG\_PP\_AVG\_TIME} + 9}$$

$$\text{Length of Short Average Window} = 2^{\text{SHORT\_PA\_AVG\_TIME}}$$

When the calculated average power exceeds a specified threshold, a trigger signal is issued. The registers to program the thresholds for the long and short average filters, along with their respective detected power calculation readbacks, are listed in Table 42.

**Table 42. PDP Threshold and Power Calculation Controls**

Register	Bits	Control
0x583	[7:0]	LONG_PA_THRESHOLD[7:0]
0x584	[4:0]	LONG_PA_THRESHOLD[12:8]
0x586	[7:0]	LONG_PA_POWER[7:0]
0x587	[4:0]	LONG_PA_POWER[12:8]
0x588	[7:0]	SHORT_PA_THRESHOLD[7:0]
0x589	[4:0]	SHORT_PA_THRESHOLD[12:8]
0x58B	[7:0]	SHORT_PA_POWER[7:0]
0x58C	[4:0]	SHORT_PA_POWER[12:8]

### Main Datapath Interpolation

The interpolation options available within the main datapath are bypass (1×), 2×, 4×, 6×, 8× and 12×. Each of the half-band filters used for interpolation have up to 80% bandwidths with 85 dB of stop band rejection. The channel half-band cascaded configuration is shown in Figure 78, with each of the useable bandwidths of the interpolation filters listed in Table 43.

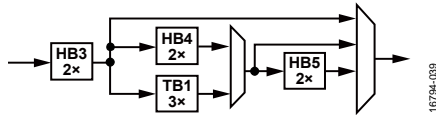

Figure 78. Main Datapath Interpolation Half-Band Filter Block Diagram

**Table 43. Main Datapath Interpolation Useable Bandwidths and Rejection**

Half-Band Filter	Bandwidth (× $f_{IN\_FILTER}$ )	Stop Band Rejection (dB)
HB3	80%	85
HB4	40%	85
TB1	27%	85
HB5	20%	85

### Main Datapath Digital Modulation

The main datapath 48-bit NCOs architecture is largely identical to the channelizer NCOs that were described in earlier sections. Their operation is similar as well. However, unlike the channelizer NCOs, the main datapath NCOs operate at a higher clock rate, the same rate as the analog DAC cores ( $f_{DAC}$ ), which allows the NCOs to generate frequencies across a wider range. See the 48-Bit Integer/Modulus NCO section for more details

NCO mode is selected as shown in Table 44. These controls are paged per the main DAC page masks, MAINDAC\_PAGE (Register 0x008, Bits[7:6]).

**Table 44. Main Modulation Mode Selection**

Modulation Mode	Modulation Type	
	Register 0x112, Bit 3	Register 0x112, Bit 2
None	0b0	0b0
48-Bit Integer NCO	0b1	0b0
48-Bit Dual Modulus NCO	0b1	0b1

The main NCO blocks also contain sideband selection controls as well as options for how the FTW and phase offset controls are updated.

The phase offset word control can be calculated as follows:

$$-180^\circ \leq \text{Degrees Offset} \leq +180^\circ$$

$$\text{Degrees Offset} = 180^\circ \times (\text{DDSM\_NCO\_PHASE\_OFFSET}/2^{15})$$

where  $\text{DDSM\_NCO\_PHASE\_OFFSET}$  is a 16-bit twos complement value programmed in the registers listed in Table 45.

**Table 45. Main Datapath NCO Phase Offset Registers**

Address	Value	Description
0x11C	DDSM_NCO_PHASE_OFFSET[7:0]	8 LSBs of phase offset
0x11D	DDSM_NCO_PHASE_OFFSET [15:8]	8 MSBs of phase offset

### 48-Bit Integer/Modulus NCO

The main datapath NCOs use a similar architecture to the channelizer NCOs, as shown in Figure 74. Because the main datapath NCOs are clocked at the same rate as  $f_{DAC}$ , this configuration allows output signals to be placed anywhere in the output spectrum up to  $\pm f_{DAC}/2$  with very fine frequency resolution.

The NCO produces a quadrature carrier to translate the input signal to a new carrier frequency, similar to the channelizer NCOs. Refer to the corresponding channelizer NCO section for more details.

The FTW for the main datapath NCOs is calculated in the same manner as the FTW for the channelizer NCOs. An important distinction is that the clock rate of the main datapath NCOs ( $f_{NCO,CLK}$ ) is equal to the DAC sample rate ( $f_{DAC}$ , 12.6 GSPS maximum). Calculate  $f_{NCO,CLK}$  using the following formula:

$$f_{NCO,CLK} = f_{DAC} = f_{DATA} \times \text{Channel Interpolation} \times \text{Main Interpolation}$$

The FTWs for each individual NCO can be programmed separately and are calculated using the following formula:

$$-f_{NCO,CLK}/2 \leq f_{CARRIER} < +f_{NCO,CLK}/2$$

$$\text{DDSM\_FTW} = (f_{CARRIER}/f_{NCO,CLK}) \times 2^{48}$$

where:

$f_{CARRIER}$  is the output frequency of the NCO.

$f_{NCO,CLK}$  is the sampling clock frequency of the NCO.

$\text{DDSC\_FTW}$  is a 48-bit, twos complement number.

The frequency tuning word is set as shown in Table 46.

**Table 46. Main Datapath NCO FTW Registers**

Address	Value	Description
0x114	DDSM_FTW[7:0]	8 LSBs of FTW
0x115	DDSM_FTW[15:8]	Next 8 bits of FTW
0x116	DDSM_FTW[23:16]	Next 8 bits of FTW
0x117	DDSM_FTW[31:24]	Next 8 bits of FTW
0x118	DDSM_FTW[39:32]	Next 8 bits of FTW
0x119	DDSM_FTW[47:40]	8 MSBs of FTW

Unlike other NCO control registers, the FTW registers are not applied to the NCO block immediately on writing the control register. Instead, the FTW registers are applied (reset) on the rising edge of DDSM\_FTW\_LOAD\_REQ (Register 0x113, Bit 0). After an update request, DDSM\_FTW\_LOAD\_ACK (Register 0x113, Bit 1) must indicate a high status to acknowledge that the FTW is updated.

The DDSM\_SEL\_SIDE BAND bit Register 0x112, Bit 1 = 0b1) is a convenience bit that controls whether the lower or upper sideband of the modulated data is used, which is equivalent to flipping the sign of the FTW.

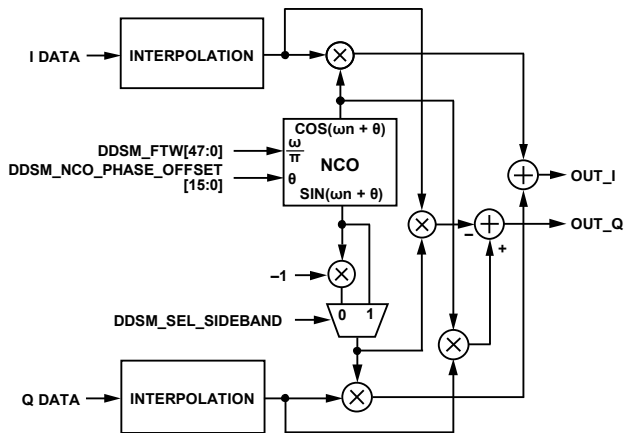

Figure 79. NCO Modulator Block Diagram, Main Datapath Modulus NCO Mode (DDS)

Each of the main datapath 48-bit NCOs can also be used in a dual modulus mode to create fractional frequencies beyond the 48-bit accuracy. The modulus mode is enabled by programming the DDSM\_MODULUS\_EN bit in the DDSM\_DATAPATH\_CFG register to 1 (Register 0x112, Bit 2 = 0b1).

The main datapath modulus NCOs are of a similar architecture to the channel modulus NCOs, and the X (FTW), A, and B values are calculated in a similar manner:

$$\frac{f_{CARRIER}}{f_{NCO,CLK}} = \frac{M}{N} = \frac{X + \frac{A}{B}}{2^{48}}$$

where:

X is the FTW, programmed in Register 0x114 to Register 0x119.

A is programmed in Register 0x12A to Register 0x12F.

B is programmed in Register 0x124 to Register 0x129.

For more details and examples, see the Channel Modulus NCO Mode (Direct Digital Synthesis (DDS) Mode) section. The main datapath NCOs operate at a higher clock rate ( $f_{NCO,CLK}$ ) than the channel NCOs, and are addressed from a different set of SPI registers.

**NCO Reset**

Resetting the main datapath NCOs can be useful when determining the start time and phase of an NCO. Each NCO can be configured to reset in response to one of several events: a direct request via SPI (Register 0x113, Bit 0), a change to one of the FTW register values, or on the next SYSREF± rising edge. The reset method is controlled by Register 0x113. See the detailed description of Register 0x113 in Table 62 for more information.

**Fast Frequency Hopping (FFH)**

Each main datapath NCO in the AD9174 has several features that allow FFH between preconfigured carrier frequencies. The main 48-bit NCO is a general-purpose NCO, combined with a bank of 31 FFH NCOs, with 32 bits each.

**FFH NCO**

Each FFH NCO is implemented within the main 48-bit NCO, with an associated bank of 31 FTWs located in Register 0x806 to Register 0x881. The FTW registers can be preloaded with tuning words that are loaded into the hopping frequency register bank when the particular NCO is reset. Any of the 32 FTWs can be selected by a single register write to the HOPF\_SEL bits in the DDSM\_HOPF\_CTRL register (Register 0x800, Bits[4:0]). The manner in which the phase of a particular NCO transitions as it hops between carrier frequencies is determined by the NCO frequency change mode. These modes include phase continuous hopping, phase discontinuous hopping, and phase coherent hopping. The hopping modes are controlled by Register 0x800, Bits[7:6], as described in Table 47.

**Table 47. NCO Frequency Change Mode**

Register 0x800, Bits[7:6]	Description
0b00	Phase continuous switch
0b01	Phase discontinuous switch (reset NCO accumulator)
0b10	Phase coherent switch

In phase discontinuous mode, the FTW of the NCO is updated and the phase accumulator is reset, resulting in an abrupt phase change each time the NCO hops to a new frequency. The discontinuous phase may result in an undesirable glitch at the transition point. Alternatively, in phase continuous switching, the frequency tuning word of the NCO is updated, while the main phase accumulator maintains count throughout the update, resulting in a smooth phase transition between carrier frequencies.

In phase coherent mode, a bank of 31 additional phase accumulators is enabled, which maintains count regardless of which accumulator value is applied to the main accumulator. The result is that the phase of all 32 FTWs is known at all times for each carrier frequency, thus allowing to maintain phase coherency between hops, relative to Time 0 (the time when the NCO was last reset). Therefore, it is recommended to preload all FTWs and only then select the phase coherent switch mode so that the NCO phase accumulators start at the same time.

To conserve power, each of the 31 additional NCOs is enabled only when its corresponding FTW is programmed to a value other than 0x0. All NCO FTWs have a default value of 0x0. Note that the main phase accumulator (corresponding to the 48-bit FTW, namely FTW0), is concurrently enabled by the DDSM\_NCO\_EN bit in the DDSM\_DATAPATH\_CFG register (Register 0x112, Bit 3 = 0b1).

Each of the 32-bit NCOs can be powered down at the convenience of the user. If a 32-bit NCO is initially powered up, it is recommended to first program the FTW to 0x0001 to flush the accumulator from any residual values, and only then program the FTW to 0x0000, which powers down the NCO output, but not the accumulator. This method avoids the possibility of any residual spurious tones appearing at the output of adjacent NCOs during power-down, however unlikely.

#### **Calibration NCO**

In addition to the 48-bit NCO and the 31, 32-bit NCOs, there is a 32-bit calibration NCO, which is also part of the main datapath NCO block, shown in Figure 74. This NCO is separate from the 48-bit NCO, allowing a convenient method for generating a calibration tone without the need to modify the configuration of the main datapath. Similar to all other NCOs, this NCO can be used in NCO only mode, or used to translate incoming data to a new carrier frequency. Register 0x1E6, Bit 0 controls whether the 32-bit calibration NCO is connected to the main datapath, or whether the normal 48-bit main NCO is connected instead. To use the 32-bit calibration NCO, first enable the calibration NCO accumulator by setting Register 0x1E6, Bit 2 = 1. Then, program the calibration NCO FTW in Register 0x1E2 to Register 0x1E5 and update the FTW to take effect by toggling Register 0x113, Bit 0 from 0 to 1. Select the calibration NCO to be used instead of the main NCO by setting Register 0x1E6, Bit 0 = 1. Similar to other NCOs, the calibration NCO can be configured to operate in NCO only mode, which is enabled by setting Register 0x1E6, Bit 1 = 1.

Set the amplitude of the tone can be set in Registers 0x148 and Register 0x149. Refer to the NCO Only Mode section for more details.

#### **NCO ONLY MODE**

The AD9174 NCOs can operate in standalone mode, where the JESD204B link is disconnected (or disabled) and one or more NCO tones are output from DAC0 and/or DAC1. The correct JESD204B mode must still be selected to configure the corresponding channelizer and/or main datapath clock domains. In NCO only mode, a single-tone sine wave is generated by each NCO by modulating the NCO output with dc samples that are generated internally. The amplitude of the dc samples directly corresponds to the amplitude of the NCO tone output by the DAC core. The amplitude of each channel NCO can be controlled independently by paging the correct channel register (Register 0x148 and Register 0x149). Note that the main NCO amplitude is controlled by paging Channel 0 for Channel NCO0 and Channel 1 for Channel NCO1 (the dc word is shared between Channel NCOx and the main NCOx channel).

The data source of the digital datapaths in NCO only mode is the dc data word, meaning that whether the JESD204B link is initially brought up or not, the data from the link is not passed to the datapaths. However, the input to the datapaths is easily switched between the dc data input and SERDES block input, by either Register 0x130 or Register 0x1E6, depending on the datapath. The connection can be made on-the-fly, assuming that a JESD204B link is previously configured and proper data samples are supplied. During the transition, sensitive external components can be protected using the PA protection block as previously described.

To use any of the NCOs in NCO only mode, the user can elect to configure the AD9174 to operate in JESD204B Mode 0, Mode 1, or Mode 2, depending on the desired number of channel NCOs. Any other JESD204B mode can be selected instead, as long as the NCO is not bypassed (interpolation = 1). To enable the NCOs that connect to DAC1, a dual-link JESD204B mode can be configured. It is not necessary to establish the JESD204B link with an external source, such as an FPGA, and instead only a few SPI register writes are needed to enable the necessary JESD204B mode to set up the clock domains corresponding to each NCO.

In general, NCO only mode is useful to bring up a transmitter radio signal chain without requiring a digital data source initially, or in applications where a sine wave output is all that is required (also known as DDS mode), such as in local oscillator (LO) generation or radar applications.

There is an additional optional calibration NCO block that can be used as part of the initial system calibration without otherwise making changes to the configuration of the digital datapath.

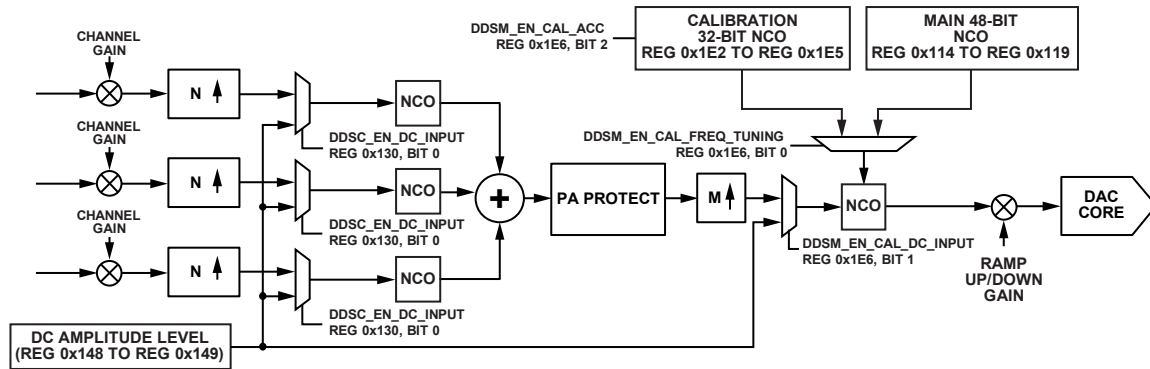

Figure 80. DC Amplitude Injection for NCO Only Mode Block Diagram

16794-148

**MODULATOR SWITCH**

For added flexibility, the final NCO block (NCO0 and NCO1, to correspond to the DAC core they feed by default, in Configuration 0) includes a modulator switch that allows the user to route the desired I and/or Q sample to one or all DAC cores. NCO<sub>x</sub> are located near the output of their respective main digital datapaths. The switch has four configurations, as shown in Figure 81 through Figure 84. Some configurations bypass the NCO altogether and route the complex I and Q samples from each datapath to the DAC

core(s), whereas other modes route the output of the NCOs instead. Of particular interest may be Configuration 2, shown in Figure 83, where I samples are sent to DAC0 and Q samples are sent to DAC1, to operate the AD9174 as a traditional IF DAC. Configuration 3 routing also depends on whether NCO1 and/or DAC1 is enabled. The configurations are set via Register 0x112, Bits[5:4] and are paged by the MAINDAC\_PAGE register control.

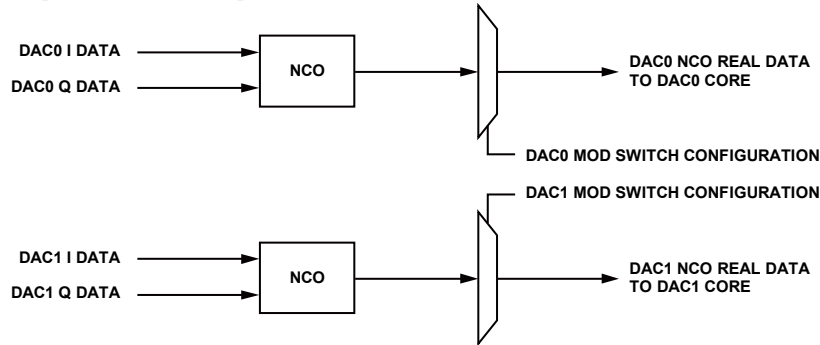

Figure 81. Configuration 0—DAC0 = I0, DAC1 = I1

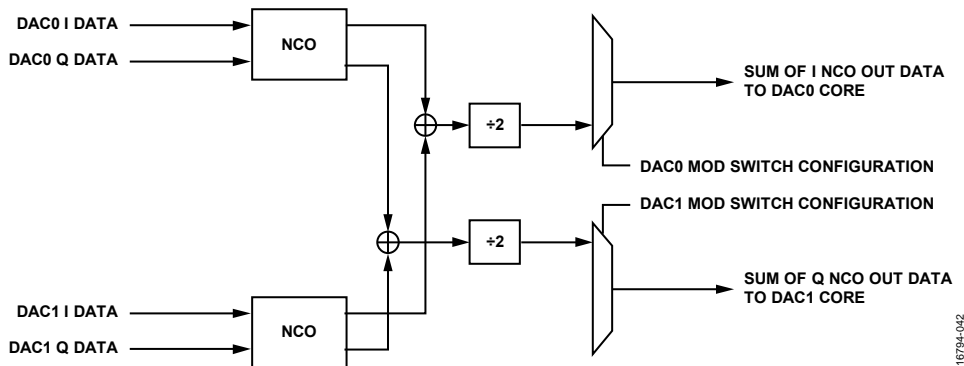

Figure 82. Configuration 1, CMLX\_MOD\_DIV2\_DISABLE = 0—DAC0 = I0 + I1, DAC1 = Q0 + Q1

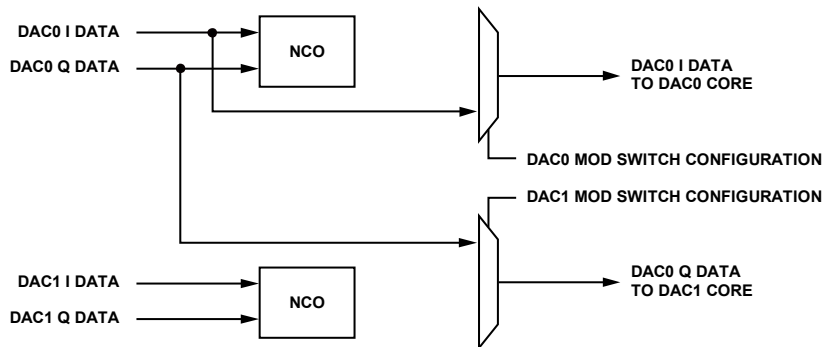

Figure 83. Configuration 2—DAC0 = I0, DAC1 = Q0

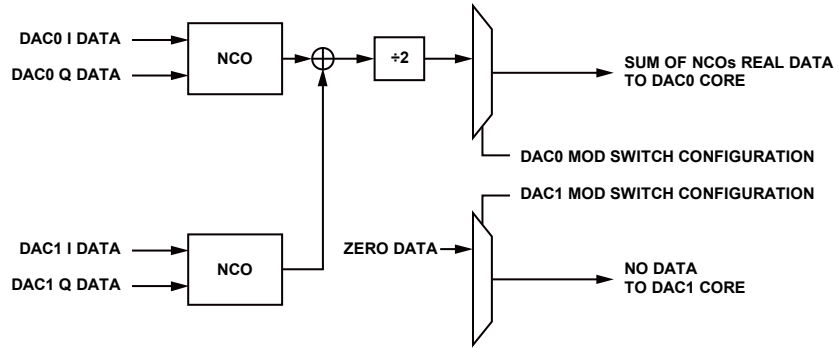

Figure 84. Configuration 3,  $CMPLEX\_MOD\_DIV2\_DISABLE = 0$ —DAC0 = I0 + I1, DAC1 = 0

1679A-014

**Complex Modulator Switch Configurations**

The switch configurations described previously only support complex samples with the NCO bypassed. To support complex samples where the NCO is used, Configuration 3 can be additionally reconfigured to operate on complex samples at the output of the NCO(s), controlled by the EN\_CMPLX\_MOD bit (Register 0x112, Bit 6). The specific configuration also depends on whether NCO1 is enabled, as shown in Figure 85 and Figure 86.

To set up Configuration 3A, set the EN\_CMPLX\_MOD bit to 1 and set the switch to Configuration 3, with both NCO0 and NCO1 enabled. The quadrature output of the NCO from each main datapath is also routed to DAC1 (no longer sends zero data out of DAC1 as in the default Configuration 3, shown in Figure 84). If NCO1 is disabled and EN\_CMPLX\_MOD = 1,

the real output of NCO0 is sent to DAC0 and the quadrature output of the NCO0 is set to DAC 1. This setup is similar to Configuration 2, but with the samples picked up at the output of NCO0 (see Figure 85 and Figure 86).

The divide by 2 block at the input of the mux switch can be disabled using the CMPLX\_MOD\_DIV2\_DISABLE bit in Register 0x0FF. Otherwise, the output at DAC0 and DAC1 is 6 dB lower than anticipated because the divide by 2 block is enabled by default.

The complete list of SPI writes required to enable each configuration is shown in Table 48.

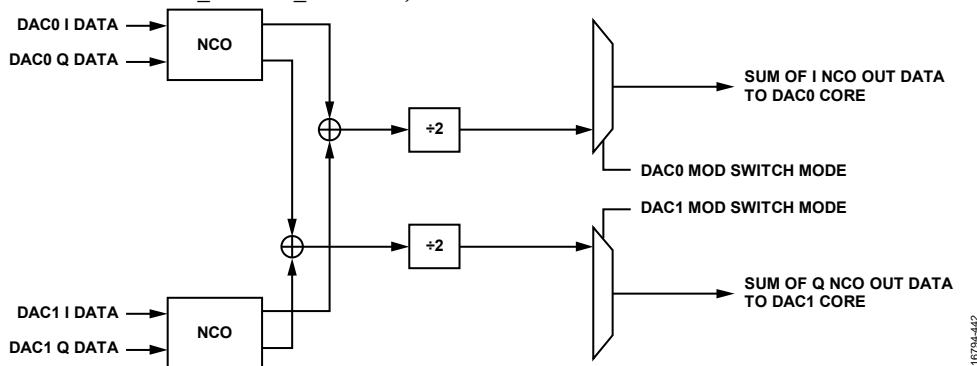

Figure 85. Configuration 3A, EN\_CMPLX\_MOD = 1, CMPLX\_MOD\_DIV2\_DISABLE = 0, both Main NCOs Enabled—DAC0 = I0\_NCO + I1\_NCO, DAC1 = Q0\_NCO + Q1\_NCO

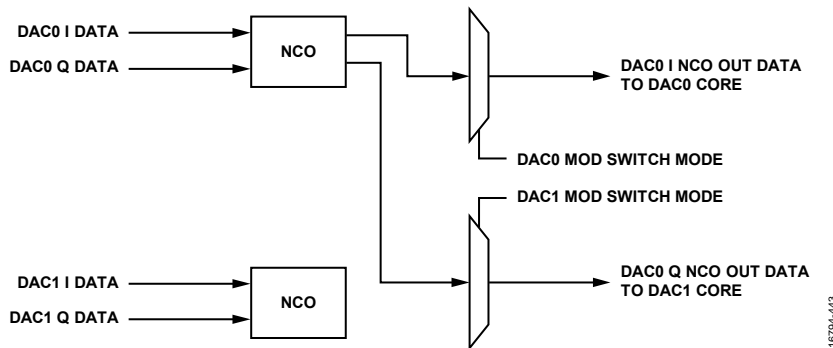

Figure 86. Configuration 3B, EN\_CMPLX\_MOD = 1, CMPLX\_MOD\_DIV2\_DISABLE = 1, DAC 1 Main NCO Disabled—DAC0 = I0\_NCO, DAC1 = Q0\_NCO

**Table 48. Required SPI Writes for Each Modulator Switch Configuration**

Configuration	Register 0x112, Bit 6 (EN_COMPLEX_MOD)	Register 0x112, Bits[5:4] (DDSM_MODE)	Register 0x112, Bit 3 (Paged)		Register 0x0FF, Bit 1 (CMPLX_MOD_DIV2_DISABLE)
			NCO0 Enable	NCO1 Enable	
Configuration 0	0	0	1	1	0
Configuration 1	0	1	0	0	0
Configuration 2	0	2	0	0	0
Configuration 3	0	3	1	1	0
Complex Configuration 3A	1	3	1	1	0
Complex Configuration 3B	1	3	1	0	1

**Ramp-Up/Ramp-Down Gain Block**

A ramp-up/ramp-down gain block is located at the output of each main datapath and before the samples are routed to the analog DAC core(s) for decoding. This block is an extension of the PDP block, and together these blocks protect downstream components from large signal peaks or sustained average power that exceeds a user defined threshold.

Various trigger methods can be configured in the PA protection block to trigger a gain ramp-down to mute the data being transmitted out of the AD9174, as shown in Figure 76. The ramp-up and ramp-down steps can be configured via the SPI in Register 0x580, Bits[2:0]. The equation for the ramp-up and ramp-down occurs in 32 steps over  $2^{(\text{CODE} + 8)}$  DAC clock periods. This control can be configured individually for each of the DAC ramp blocks via the MAINDAC\_PAGE control in Register 0x008.

After the data is ramped down due to a trigger event, it can be ramped back up in two different ways, assuming the trigger event (error) was cleared. If the SPI protection control bit triggered the interrupt for a ramp-down, the data can be ramped-up by toggling Register 0x582, Bit 7 from 0 to 1, and then back to 0. Alternatively, an option exists to mute the digital data during a digital clock rotation if the ROTATE\_SOFT\_OFF\_EN control in Register 0x581, Bit 2 is set to 1. When this bit is set, a synchronization logic rotation triggers the ramp-up/ramp-down block to ramp the output down, rotates the digital clocks, and then ramps the output back up. These actions occur only if Bit 1 of the ROTATION\_MODE control in Register 0x03B is set to 1 to enable a datapath clock rotation when the synchronization logic rotates.

## INTERRUPT REQUEST OPERATION

The AD9174 provides an interrupt request output signal ( $\overline{\text{IRQ}}$ ) on Pin D9 ( $\overline{\text{IRQ0}}$ ) and Pin E9 ( $\overline{\text{IRQ1}}$ ) that can be used to notify an external host processor of significant device events. The  $\overline{\text{IRQ}}$  output can be switched between the  $\overline{\text{IRQ0}}$  pin or the  $\overline{\text{IRQ1}}$  pin by setting the corresponding bit for the  $\overline{\text{IRQ}}$  signal in Register 0x028, Register 0x029, Register 0x02A, and Register 0x02B. Upon assertion of the interrupt, query the device to determine the precise event that occurred. The  $\overline{\text{IRQx}}$  pins are open-drain, active low outputs. Pull the  $\overline{\text{IRQx}}$  pins high, external to the device. These pins can be tied to the interrupt pins of other devices with open-drain outputs to wire. OR these pins together.

Figure 87 shows a simplified block diagram of how the  $\overline{\text{IRQx}}$  blocks works. If  $\overline{\text{IRQ\_EN}}$  is low, the  $\text{INTERRUPT\_SOURCE}$  signal is set to 0. If  $\overline{\text{IRQ\_EN}}$  is high, any rising edge of  $\text{EVENT}$  causes the  $\text{INTERRUPT\_SOURCE}$  signal to be set high. If any  $\text{INTERRUPT\_SOURCE}$  signal is high, the  $\overline{\text{IRQx}}$  pin is pulled low.  $\text{INTERRUPT\_SOURCE}$  can be reset to 0 by either an  $\overline{\text{IRQ\_RESET}}$  signal or a  $\overline{\text{DEVICE\_RESET}}$  signal.

Depending on the  $\text{STATUS\_MODE}$  signal,  $\text{EVENT\_STATUS}$  reads back an event signal or an  $\text{INTERRUPT\_SOURCE}$  signal. The AD9174 has several  $\overline{\text{IRQ}}$  register blocks that can monitor up to 86 events, depending on the device configuration. Certain details vary by  $\overline{\text{IRQ}}$  register block, as described in Table 49. Table 50 shows the source registers of the  $\overline{\text{IRQ\_EN}}$ ,  $\overline{\text{IRQ\_RESET}}$ , and  $\text{STATUS\_MODE}$  signals in Figure 87, as well as the address where  $\text{EVENT\_STATUS}$  is read back.

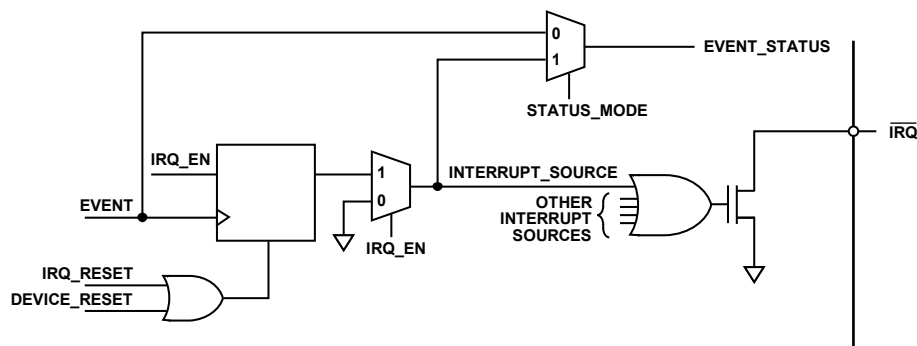

Figure 87. Simplified Schematic of  $\overline{\text{IRQx}}$  Circuitry

Table 50.  $\overline{\text{IRQ}}$  Register Block Address of  $\overline{\text{IRQ}}$  Signal Details

Register Block	Address of $\overline{\text{IRQ}}$ Signals <sup>1</sup>			
	$\overline{\text{IRQ\_EN}}$	$\overline{\text{IRQ\_RESET}}$	$\text{STATUS\_MODE}$	$\text{EVENT\_STATUS}$
0x020 to 0x023	0x020 to 0x023; R/W per chip	0x024 to 0x027; per chip	$\text{STATUS\_MODE} = \overline{\text{IRQ\_EN}}$	0x024 to 0x027; R per chip
0x4B8 to 0x4BB	0x4B8, 0x4B9; W per error type	0x4BA, 0x4BB; W per error type	Not applicable, $\text{STATUS\_MODE} = 1$	0x4BA, 0x4BB; W per chip
0x470 to 0x473	0x470 to 0x473; W per error type	0x470 to 0x473; W per link	Not applicable, $\text{STATUS\_MODE} = 1$	0x470 to 0x473; W per link

<sup>1</sup> R is read, W is write, and R/W is read/write.

Table 49.  $\overline{\text{IRQ}}$  Register Block Details

Register Block	Event Reported	$\text{EVENT\_STATUS}$
0x020 to 0x027	Per chip	$\text{INTERRUPT\_SOURCE}$ if $\overline{\text{IRQ}}$ is enabled; if not, it is an event
0x4B8 to 0x4BB; 0x470 to 0x473	Per link and lane	$\text{INTERRUPT\_SOURCE}$ if $\overline{\text{IRQ}}$ is enabled; if not, 0

### INTERRUPT SERVICE ROUTINE

Interrupt request management starts by selecting the set of event flags that require host intervention or monitoring. Enable the events that require host action so that the host is notified when they occur. For events requiring host intervention upon  $\overline{\text{IRQ}}$  activation, run the following routine to clear an interrupt request:

1. Read the status of the event flag bits that are being monitored.
2. Disable the interrupt by writing 0 to  $\overline{\text{IRQ\_EN}}$ .
3. Read the event source.
4. Perform any actions that may be required to clear the cause of the event. In many cases, no specific actions may be required.
5. Verify that the event source is functioning as expected.
6. Clear the interrupt by writing 1 to  $\overline{\text{IRQ\_RESET}}$ .
7. Enable the interrupt by writing 1 to  $\overline{\text{IRQ\_EN}}$ .

# ANALOG INTERFACE

## DAC INPUT CLOCK CONFIGURATIONS

The AD9174 DAC sample clock or device clock (DACCLK) can be received directly through CLKIN± (Pin H12 and Pin J12) or generated using an integer PLL/VCO, integrated on-chip, with the reference clock provided through the same CLKIN± differential input pins. The DACCLK serves as a reference for all the clock domains within the AD9174.

The AD9174 uses a low jitter, differential clock receiver that is capable of interfacing directly to a differential or single-ended clock source. Because the input is self biased, with a nominal impedance of 100 Ω, it is recommended that the clock source be ac-coupled to the CLKIN± input pins. Phase noise performance can be improved with higher clock input levels (larger swing, resulting in higher effective slew rate), up to the recommended maximum limits. Because the DACCLK is the sampling clock for data within the analog cores (DACx), the quality of the clock signal at the AD9174 clock input pins is paramount and directly impacts the analog ac performance of the DAC. Select a clock source with phase noise and spur characteristics that meet the target application requirements. Generally, the use of a PLL/VCO or other clock multipliers, internal or external to the DAC, also multiplies the resulting phase noise (jitter). The best phase noise performance is typically achieved using an external clock running at the desired DAC clock rate, with the PLL/VCO bypassed.

In cases where low phase noise is not a critical requirement, the PLL/VCO provides a convenient way to operate the AD9174 at DAC clock rates as high as 12.4 GHz without the need for complex, multigigahertz clocking solutions. The PLL reference frequency at CLKIN± can be typically orders of magnitude lower than the operating DACCLK rate. The PLL then generates a control voltage for a downstream VCO, which in effect multiplies the reference clock up to the desired DACCLK frequency.

The typical phase noise performance when the AD9174 is directly clocked and the input clock duty cycle correction is on (enabled by default) is shown in Figure 88, compared with the phase noise due to the on-chip PLL/VCO.

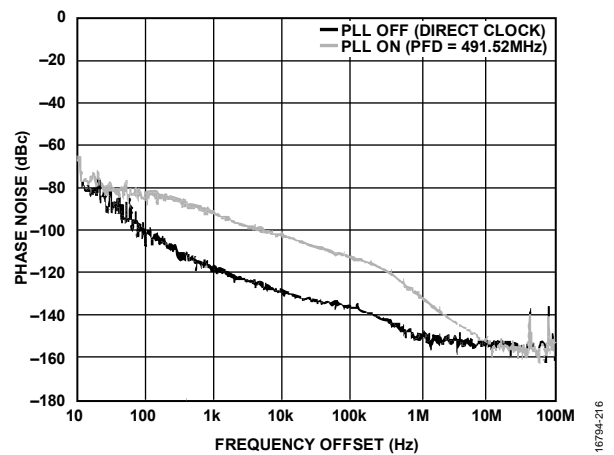

Figure 88. Phase Noise vs. Frequency Offset; Direct Clock and PLL Phase Noise, 12 GHz DAC Sample Rate, 1.65 GHz Output Frequency

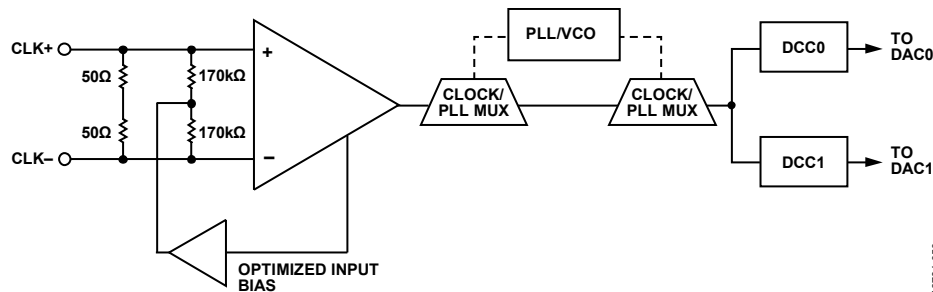

Figure 89. Clock Receiver Input Simplified Equivalent Circuit

### DAC On-Chip PLL

The AD9174 includes an integer PLL/VCO block that allows generating a DAC clock ( $f_{DAC}$ ) from an external reference frequency ( $f_{REF}$ ) between 25 MHz and 3080 MHz, applied to the CLKIN± pins (see Figure 90). When using the on-chip PLL, select the predivider ( $M$ ) via Register 0x793, Bits[1:0] to internally divide the reference frequency to be within the range of 25 MHz to 770 MHz of the phase frequency detector (PFD) circuitry block input. Enable the DAC PLL synthesizer by setting Register 0x095, Bit 0 to 0.

The internal VCO operates over a frequency range of 8.74 GHz to 12.4 GHz, with additional divider settings if a lower DACCLK is required by the application. The DAC clock rate is user configurable to be the VCO frequency (8.74 GHz to 12.4 GHz), the VCO frequency divided by 2 (4.37 GHz to 6.2 GHz), or the VCO frequency divided by 3 (2.92 GHz to 4.1 GHz) by setting Register 0x094, Bits[1:0]. See the Start-Up Sequence section for instructions on how to program the PLL.

To generate the required VCO control voltage from the charge pump (CP) output, the AD9174 DAC PLL requires an external loop filter. The recommended filter is a passive low-pass filter of a topology similar to the one shown in Figure 90. Generally, the pass band width of the filter (bandwidth) trades off loop response time during a frequency change with loop stability after the initial frequency lock occurs. For proper filter layout and component selection, which results in optimal performance for most applications, refer to the documentation of the [AD9174-FMC-EBZ](#) evaluation board. The user may however customize the filter to fit a specific application, according to the PFD

frequency, reference clock phase noise, and DAC output phase noise requirements. For example, to lower DACCLK jitter when using the PLL, a higher PFD frequency minimizes the contribution of in band noise from the PLL. Set the PLL filter bandwidth such that the in band noise of the PLL intersects with the open-loop noise of the VCO to minimize the contributions of both blocks to the overall noise.

The best jitter performance is typically achieved when using an external, high performance clock source.

The DAC PLL uses an integer type synthesizer to generate the DACCLK for both DAC0 and DAC1, implying that the generated DACCLK must be an integer multiple of the input reference clock. The relationship between DAC clock and the reference clock is as follows:

$$f_{DAC} = (8 \times N \times f_{REF}) / (M / (\text{Register } 0x094, \text{ Bits}[1:0] + 1))$$

where:

$f_{DAC}$  is the desired DAC clock rate.

$N$  is the VCO feedback divider ratio, ranging from 2 to 50.

$f_{REF}$  is the reference clock.

$M$  is the reference clock divider ratio. The valid values for reference clock divider (predivider) are 1, 2, 3, or 4 by setting Register 0x793, Bits[1:0].

The VCO automatic calibration is triggered by the falling edge of Register 0x792, Bit 1 transitioning from a logic high to logic low. A lock detector bit (Register 0x7B5, Bit 0) is provided to indicate that the DAC PLL achieved lock. If Register 0x7B5, Bit 0 = 1, the PLL has locked.

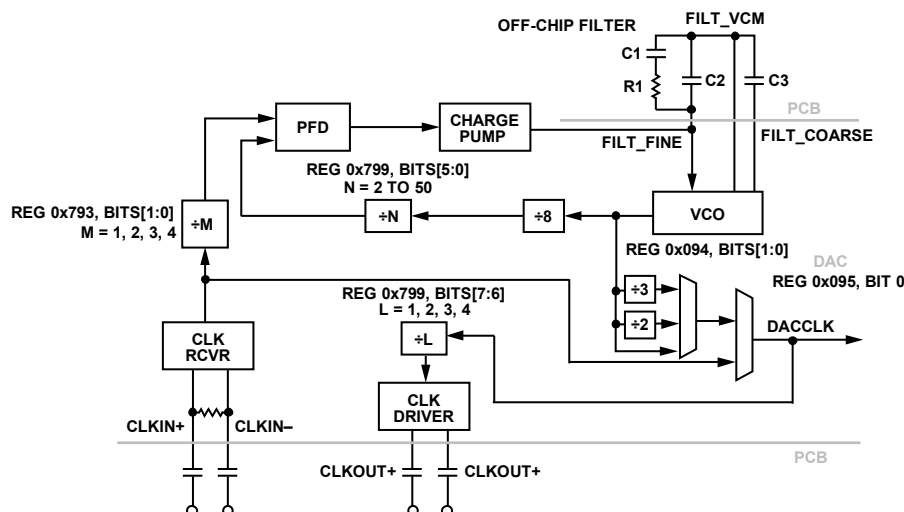

Figure 90. DAC PLL and Clock Path Block Diagram

## CLOCK OUTPUT DRIVER

The AD9174 is capable of generating a high quality, divided down version of the DACCLK, which can be used to clock critical system components, such as a companion ADC. The integer clock divider supports divide ratios of 1, 2, 3, and 4 and can be programmed by Register 0x799, Bits[7:6] to set the desired output frequency. The 3 dB bandwidth of the clock driver is between 727.5 MHz and 3 GHz, although frequencies outside this range can be generated with some penalty to both power and spurious performance at the clock output.

The clock driver does not have an impact on the performance of the DACx analog outputs.

## ANALOG OUTPUTS

The AD9174 provides two fully independent DAC cores, DAC0 and DAC1, each with a differential output. Figure 91 shows an equivalent output circuit for a single DAC core. Each output is internally terminated with a 100  $\Omega$  resistor ( $R_{INT}$ ) that eliminates the need to resistively terminate the DAC output externally on the PCB. To properly dc bias the output stage, two RF chokes, one for each output branch, are required to provide a dc current path for the standing current of each DACx output. The inductance value of the choke depends on the desired output frequency range. In general, a larger choke provides a lower cutoff output frequency.

Due to parasitic capacitances and inductances at the output, a constant 100  $\Omega$  termination impedance cannot be easily maintained across the full operating frequency range of the AD9174, which can be anywhere between dc and >6 GHz, depending on the application. The output impedance of each DAC can be determined through measurement. Generally, when matching the DAC output to a typical single-ended 50  $\Omega$  load, a 2:1 balun is recommended when operating below ~2 GHz. A 1:1 balun is recommended when operating above ~2 GHz, which also extends the 3 dB roll-off of the output beyond 4 GHz with proper PCB layout techniques.

### DAC Full-Scale Power

$I_{OUTFS}$  is the full-scale current output at the positive and negative branch of the DACx output, denoted as  $I_P$  and  $I_N$  in Figure 91 to Figure 93. The default full-scale current is set to 19.531 mA, although it can be adjusted from 15.625 mA to 25.977 mA by programming the appropriate value in Register 0x05A.

$$I_{OUTFS} = 15.625 \text{ mA} + FSC\_CTRL \times (25/256) \text{ (mA)}$$

As shown in Figure 91 to Figure 93, the amount of power delivered to an external load depends on multiple factors, such as the  $I_{OUTFS}$  setting, the internal impedance of the DAC, and the external loading and parasitic inductances and capacitances that the PCB and other components present at the output. The true power that can be delivered to a load is determined by measurements.

Alternatively, the DAC output power can be estimated from the DAC equivalent model, by making certain assumptions about the parasitic loading presented by a particular PCB design. The

DAC output can be modeled as a pair of dc current sources that continuously provide dc, set to  $I_{OUTFS}/2$ , summed with a parallel ac source set by the incoming data samples, namely DACCODE, that are sampled to the analog output at the rate of DACCLK. Together, the three current sources model the output switch network internal to each analog output, which define the instantaneous current out of the positive and negative branches of each differential output ( $I_P$  and  $I_N$ , respectively).

Assuming that parasitic capacitances and inductances are negligible (which may not always be the case, especially at output frequencies above ~2 GHz), the output current presented to the load can be calculated as follows:

$$I_P = (DACCODE + 2^{N-1}) \times I_{LSB}$$

$$I_N = ((2^{N-1} - 1) - DACCODE) \times I_{LSB}$$

and,

$$I_{LOAD} = (I_P - I_N) \times R_{INT} / (R_{INT} + R_{LOAD})$$

where,

$$I_{LSB} = I_{OUTFS} / 2^N$$

DACCODE is a sample value between  $-2^{N-1}$  and  $2^{N-1} - 1$  (as a signed decimal representation of twos complement data).

For a single-tone output (pure sinewave), the rms power delivered to the load can be calculated as follows:

$$I_{LOAD(RMS)} = I_{LOAD\_MAX} / \sqrt{2}$$

where  $I_{LOAD\_MAX}$  is the maximum load current delivered at the maximum DACCODE, as calculated previously, and,

$$P_{LOAD} \text{ (W)} = (I_{LOAD(RMS)})^2 \times R_{LOAD}$$

$$P_{LOAD} \text{ (dBm)} = 10 \times \log(P_{LOAD} \text{ (W)} \times 1000)$$

### MSB Shuffle

Depending on the analog signal level, some or all of the MSB current sources from the DAC may be static (unused). Particularly at lower signal levels, when most MSBs are static, any mismatch errors specific to the few MSBs that are dynamic may appear as a degradation to spurious performance at the analog outputs. On average, spurious performance is improved when the active MSBs are continuously remapped (or shuffled) and randomly selected from the total number of available MSBs before sampling at the DACx analog outputs. MSB shuffle is a form of error averaging. Because the cumulative errors are pseudorandom, the improved SFDR comes at the expense of higher NSD.

Shuffling is only feasible when there are spare MSBs available that are otherwise static, so that they can be randomly switched in. Therefore, the benefit from shuffling is diminished as the number of dynamic MSBs is increased, such as for signals that experience frequent peaks near the full-scale current of the DAC. With a sinusoidal output at full-scale, for example, the benefit from MSB shuffling is largely nonexistent when compared to performance with traditional (thermometer) encoding.

As previously mentioned, MSB shuffling is a form of error averaging. A particular AD9174 device, with its own auto-calibration factors and unique production process variations, may show improved spurious performance at some signal levels with MSB shuffle disabled. However, when a statically meaningful set of devices is considered, the overall spurious performance is shown to improve, on average.

MSB shuffle can be enabled via the MSB\_SHUFFLE\_EN bit (Bit 4 of Register 0x151).

### DC-Coupled Operation

In certain applications, it is desirable to dc couple the analog outputs to an external device, such as a modulator or a differential amplifier. The AD9174 analog outputs can be dc-coupled without performance degradation, as long as the common-mode voltage (the dc voltage common to both the positive and negative branches of a particular analog output) is kept below 100 mV. For ac-coupled operation, the outputs are typically dc shorted to GND or 0 V through RF chokes or particular balun configurations.

Elevating the common-mode voltage to between 100 mV and 300 mV leads to performance degradation. Increasing the common-mode voltage beyond 300 mV may lead to long-term, irreversible damage of the analog outputs.

Ideally, the common-mode voltage at the analog outputs is kept near 0 V or GND, while the load impedance seen by the analog outputs is matched to their internal impedance. Replacing the RF chokes used in ac-coupled operation with 50  $\Omega$  resistors to GND is not recommended because this results in an excessive common-mode voltage, near 250 mV. Instead, tie the 50  $\Omega$  resistors to a -0.6 V reference supply, thus maintaining proper dc bias at the analog output devices internal to each DAC output.

It is possible to resistively match the 0 V common-mode output voltage of the AD9174 to a nonzero common-mode input voltage of a downstream device, such as the 0.5 V input common mode typical to some modulators. This matching inevitably leads to a loss in the maximum power that can be delivered to the downstream device, because some of the power is dissipated in the resistive matching network.

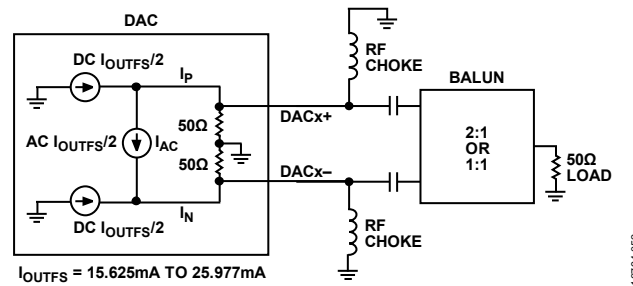

Figure 91. Equivalent DAC Output Circuit and Recommended DAC Output Network

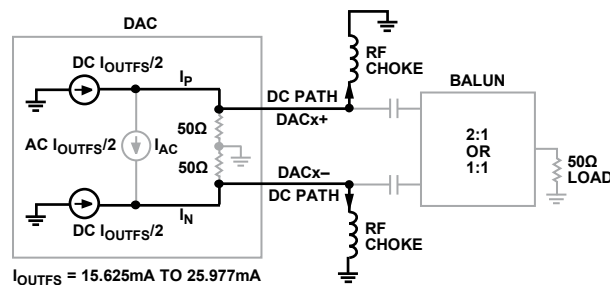

Figure 92. DACx Output, DC Path (AC-Coupled Operation)

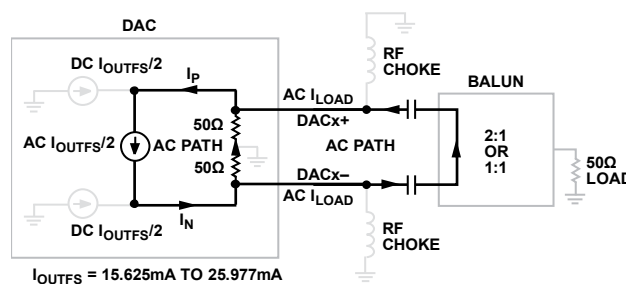

Figure 93. DACx Output, AC Path (AC-Coupled Operation)

## APPLICATIONS INFORMATION

### HARDWARE CONSIDERATIONS

#### Power Supply Recommendations

All the AD9174 supply domains must remain as noise free as possible for the best operation. Power supply noise has a frequency component that affects performance, and is specified in V rms.

An LC filter on the output of the power supply is recommended to attenuate the noise, and must be placed as close to the AD9174 as possible. The AVDD1.0 supply, which supplies the clock receiver and DAC analog core circuitry, and the AVDD1.8 supply, which powers the DAC output and DAC PLL blocks, are the most noise sensitive supplies on the device. It is highly recommended that AVDD1.0 and AVDD1.8 be supplied separately with ultralow noise regulators, such as the [ADP1763](#) and [ADM7154](#) or better to achieve the best phase noise performance possible. Noisier regulators impose phase noise onto the DAC output.

The DVDD1.0 supply provides power to the digital datapath blocks and the SVDD1.0 supply powers the SERDES circuitry on the chip. The DVDD1.8 supply powers circuitry blocks related to the SPI, SYNCOUTx± transmitter, SYSREF receiver, IRQx, RESET, and TXENx circuitry.

Take note of the maximum power consumption numbers shown in Table 4 to ensure the power supply design can tolerate temperature and IC process variation extremes. The amount of current drawn is dependent on the chosen use cases, and specifications are provided for several use cases to illustrate examples and contributions from individual blocks, and to assist in calculating the maximum required current per supply.

Another consideration for the power supply design is peak current handling capability. The AD9174 draws more current in the main digital supply when synthesizing a signal with significant amplitude variations, such as a modulated signal, as compared to when in idle mode or synthesizing a dc signal. Therefore, the power supply must be able to supply current quickly to accommodate burst signals such as GSM, TDMA, or other signals that have an on or off time domain response. Because the amount of current variation depends on the signals used, it is best to perform lab testing first to establish ranges. A typical difference can be several hundred milliamperes.

#### Power and Ground Planes

Solid ground planes are recommended to avoid ground loops and to provide a solid, uninterrupted ground reference for the high speed transmission lines that require controlled impedances. It is recommended that power planes be stacked between ground layers for high frequency filtering. Doing so adds extra filtering and isolation between power supply domains in addition to the decoupling capacitors.

Do not use segmented power planes as a reference for controlled impedances unless the entire length of the controlled impedance trace traverses across only a single segmented plane. These and additional guidelines for the topology of high speed transmission lines are described in the JESD204B Serial Interface Inputs (SERDIN0± to SERDIN7±) section.

For some applications, where highest performance and higher output frequencies are required, the choice of PCB materials significantly impacts results. For example, materials such as polyimide or materials from the Rogers Corporation can be used, for example, to improve tolerance to high temperatures and improve performance. Rogers 4350 material is used for the top three layers in some of the evaluation board designs: between the top signal layer and the ground layer below it.

#### JESD204B Serial Interface Inputs (SERDIN0± to SERDIN7±)

When considering the layout of the JESD204B serial interface transmission lines, there are many factors to consider to maintain optimal link performance. Among these factors are insertion loss, return loss, signal skew, and the topology of the differential traces.

#### Insertion Loss

The JESD204B specification limits the amount of insertion loss allowed in the transmission channel (see Figure 56). The AD9174 equalization circuitry allows significantly more loss in the channel than is required by the JESD204B specification. It is still important that the designer of the PCB minimize the amount of insertion loss by adhering to the following guidelines:

- Keep the differential traces short by placing the AD9174 as close to the transmitting logic device as possible and routing the trace as directly as possible between the devices.
- Route the differential pairs on a single plane using a solid ground plane as a reference. It is recommended to route the SERDES lanes on the same layer as the AD9174 to avoid vias being used in the SERDES lanes.
- Use a PCB material with a low dielectric constant (<4) to minimize loss, if possible.

When choosing between the stripline and microstrip techniques, keep in mind the following considerations: stripline has less loss (see Figure 57 and Figure 58) and emits less EMI, but requires the use of vias that can add complexity to the task of controlling the impedance. The microstrip technique is easier to implement (if the component placement and density allow routing on the top layer) and eases the task of controlling the impedance.

If using the top layer of the PCB is problematic or the advantages of stripline are desirable, follow these recommendations:

- Minimize the number of vias.
- If possible, use blind vias to eliminate via stub effects and use microvias to minimize via inductance.
- If using standard vias, use the maximum via length to minimize the stub size. For example, on an 8-layer board, use Layer 7 for the stripline pair (see Figure 94).
- For each via pair, place a pair of ground vias adjacent to them to minimize the impedance discontinuity (see Figure 94).

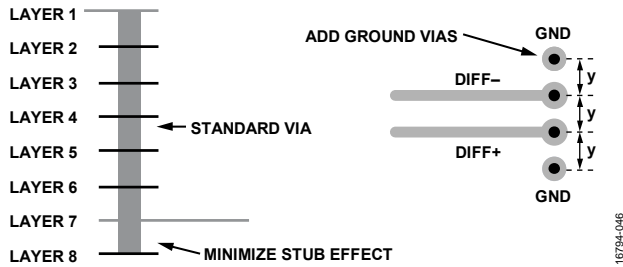

Figure 94. Minimizing Stub Effect and Adding Ground Vias for Differential Stripline Traces

### Return Loss

The JESD204B specification limits the amount of return loss allowed in a converter device and a logic device but does not specify return loss for the channel. However, make every effort to maintain a continuous impedance on the transmission line between the transmitting logic device and the AD9174. Minimizing the use of vias, or eliminating them entirely, reduces one of the primary sources for impedance mismatches on a transmission line (see the Insertion Loss section). Maintain a solid reference beneath (for microstrip) or above and below (for stripline) the differential traces to ensure continuity in the impedance of the transmission line. If the stripline technique is used, follow the guidelines listed in the Insertion Loss section to minimize impedance mismatches and stub effects.

Another primary source for impedance mismatch is at either end of the transmission line, where care must be taken to match the impedance of the termination to that of the transmission line. The AD9174 handles this matching internally with a calibrated termination scheme for the receiving end of the line. See the Interface Power-Up and Input Termination section for details on this circuit and the calibration routine.

### Signal Skew

There are many sources for signal skew, but the two sources to consider when laying out a PCB are interconnect skew within a single JESD204B link and skew between multiple JESD204B links. In each case, keeping the channel lengths matched to within 10 mm (calculated by  $12.5 \text{ mm} \times (12.5 \text{ Gbps}/15.4 \text{ Gbps})$ ) is adequate for operating the JESD204B link at speeds of up to 15.4 Gbps. This amount of channel length match is equivalent to about 85% UI on the AD9174-FMC-EBZ evaluation board. Managing the interconnect skew within a single link is straightforward. Managing multiple links across multiple

devices is more complex. However, follow the 10 mm guideline for length matching. The AD9174 can handle more skew than the 85% UI due to the 6 PCLK buffer in the JESD204B receiver, but matching the channel lengths as close as possible is still recommended.

### Topology

Structure the differential SERDIN $\pm$  pairs to achieve 50  $\Omega$  to ground for each half of the pair. Stripline vs. microstrip trade-offs are described in the Insertion Loss section. In either case, it is important to keep these transmission lines separated from potential noise sources, such as high speed digital signals and noisy supplies. If using stripline differential traces, route them using a coplanar method, with both traces on the same layer. Although this method does not offer more noise immunity than the broadside routing method (traces routed on adjacent layers), it is easier to route and manufacture so that the impedance continuity is maintained. Broadside vs. coplanar differential transmitter (Tx) lines are shown in Figure 95.

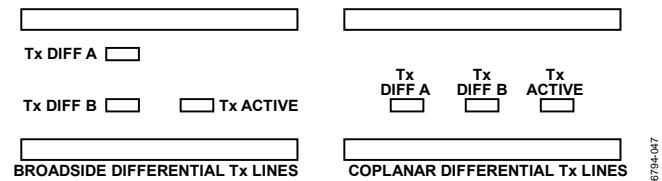

Figure 95. Broadside vs. Coplanar Differential Stripline Routing Techniques

When considering the trace width vs. copper weight and thickness, the speed of the interface must be considered. At multigigabit speeds, the skin effect of the conducting material confines the current flow to the surface. Maximize the surface area of the conductor by making the trace width wider to reduce the losses. Additionally, loosely couple differential traces to accommodate the wider trace widths. This coupling helps reduce the crosstalk and minimize the impedance mismatch when the traces must separate to accommodate components, vias, connectors, or other routing obstacles. Tightly coupled vs. loosely coupled differential traces are shown in Figure 96.

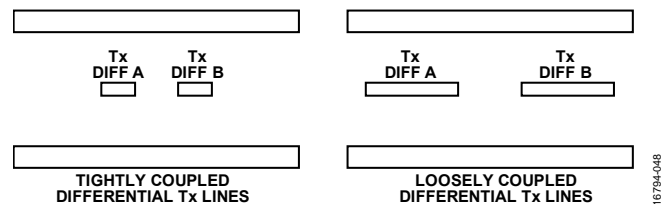

Figure 96. Tightly Coupled vs. Loosely Coupled Differential Traces

### AC Coupling Capacitors

The AD9174 requires that the JESD204B input signals be ac-coupled to the source. These capacitors must be 100 nF and placed as close as possible to the transmitting logic device. To minimize the impedance mismatch at the pads, select the package size of the capacitor so that the pad size on the PCB matches the trace width as closely as possible.

***SYNCOUT±, SYSREF±, and CLK± Signals***

The SYSREF± signal on the AD9174 is a low speed, LVDS, differential signal. The SYNCOUTx± signals are LVDS or CMOS selectable. When LVDS mode is selected, use controlled impedance traces routed as 100 Ω differential impedance and 50 Ω to ground when routing these signals. As with the SERDIN0± to SERDIN7± data pairs, it is important to keep these signals separated from potential noise sources, such as high speed digital signals and noisy supplies. Separate the

SYNCOUTx± signal from other noisy signals because noise on the SYNCOUTx± may be interpreted as a request for /K/ characters. It is important to keep similar trace lengths for the CLK± and SYSREF± signals from the clock source to each of the devices on either end of the JESD204B links (see Figure 97). If using a clock chip that can tightly control the phase of CLK± and SYSREF±, the trace length matching requirements are greatly reduced.

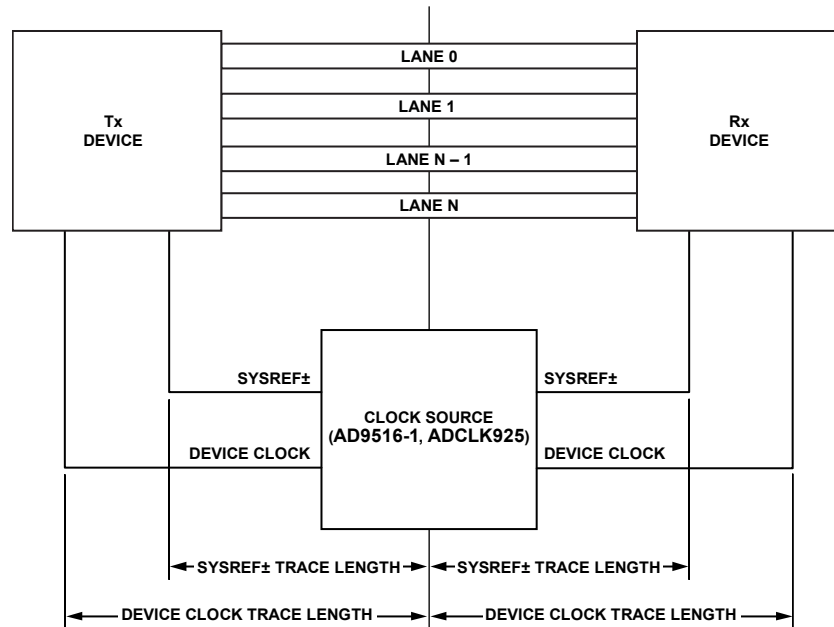

Figure 97. SYSREF± Signal and Device Clock Trace Length

18794-049

## START-UP SEQUENCE

Several steps are required to program the AD9174 to the proper operating state after the device is powered up. This sequence is divided into several steps, and is listed in Table 51 to Table 60, along with an explanation of the purpose of each step. Private

registers are reserved but must be written for proper operation. Blank cells or cells with a variable or bit field name (in all capital letters) in Table 51 to Table 60 indicate that the value depends on the result as described in the Description column.

**Table 51. Power-Up and Required Register Writes**

R/W	Register	Bits	Value	Description
W	0x000	[7:0]	0x81	Soft reset.
W	0x000	[7:0]	0x3C	Release reset and set to 4-wire SPI (optional; leave at the default of the 3-wire SPI).
W	0x091	[7:0]	0x00	Power up clock receiver.
W	0x206	[7:0]	0x01	Take PHYs out of reset.
W	0x705	[7:0]	0x01	Enable boot loader.
W	0x090	[7:0]	0x00	Power on DACs and bias circuitry.

**Table 52. DAC PLL Configuration**

R/W	Register	Bits	Value	Description
W	0x095	[7:0]	0x00 or 0x01	Bypass PLL. Set to 0x00 to use internal DAC PLL. If the user plans to supply the DAC clock directly, set this register to 0x01 and execute the following two register writes; then, skip the remaining writes in this table.
W	0x790	[7:0]	0xFF or 0x00	Write this register to 0xFF if bypassing the PLL (Register 0x095 = 0x01). If using the PLL, write this register to 0x00.
W	0x791	[7:0]	0x1F or 0x00	Write this register to 0xFF if bypassing the PLL (Register 0x095 = 0x01) and then skip the remaining register writes in this table and continue to Table 53. If using the PLL, write this register to 0x00 as well as the remainder of the register writes in this table.
W	0x796	[7:0]	0xE5	DAC PLL required write.
W	0x7A0	[7:0]	0xBC	DAC PLL required write.
W	0x794	[5:0]	DACPLL_CP	Set DAC PLL charge pump current. The recommended setting is 0x08, but can range from 0x04 to 0x10 for different phase noise performance targets.
W	0x797	[7:0]	0x10	DAC PLL required write.
W	0x797	[7:0]	0x20	DAC PLL required write.
W	0x798	[7:0]	0x10	DAC PLL required write.
W	0x7A2	[7:0]	0x7F	DAC PLL required write.
	Pause			Wait 100 ms.
W	0x799	[7:6]	ADC_CLK_DIVIDER	DAC PLL divider settings. ADC driver/clock output divide ratio. 0b00 = ÷1. 0b01 = ÷2. 0b10 = ÷3. 0b11 = ÷4.
		[5:0]	N_DIVIDER	Programmable N divider. $N\_DIVIDER = (f_{DAC} \times M\_DIVIDER) / (8 \times \text{reference clock})$ .
W	0x793	[7:2]	0x06	DAC PLL divider settings. Keep default value for these bits.
		[1:0]	M_DIVIDER_1	Programmable predivider M_DIVIDER_1 (in n – 1 notation). The relevant calculation is as follows: $PFD \text{ Frequency} = \text{reference clock} / M\_DIVIDER$ 0b00 = ÷1. 0b01 = ÷2. 0b10 = ÷3. 0b11 = ÷4.

R/W	Register	Bits	Value	Description
W	0x094	[7:2]	0x00	Keep default value for these bits.
		1	PLL_VCO_DIV3_EN	Enable PLL output clock to be divided by 3. If this bit is set to 1, DAC clock = PLL VCO frequency/3.
		0	PLL_VCO_DIV2_EN	Enable PLL output clock to be divided by 2. Either this bit or Bit 1 in this register can be set to 1, but both bits cannot be set at the same time (there is no divide by 6 option). 0b0: DAC clock = PLL VCO frequency. 0b1: DAC clock = PLL VCO frequency/2.
W	0x792	[7:0]	0x02	Reset VCO.
W	0x792	[7:0]	0x00	
	Pause			Wait 100 ms for PLL to lock.
R	0x7B5	0	0b1	Ensure PLL is locked by reading back a value of 1 for bit 0 of this register.

Table 53. Delay Lock Loop (DLL) Configuration

R/W	Register	Bits	Value	Description
W	0x0C0	[7:0]	0x00	Power-up delay line.
W	0x0DB	[7:0]	0x00	
W	0x0DB	[7:0]	0x01	Update DLL settings to circuitry.
W	0x0DB	[7:0]	0x00	
W	0x0C1	[7:0]	0x68 or 0x48	Set DLL search mode. If $f_{DAC}$ is < 4.5 GHz, set this register to 0x48. Otherwise, set this register to 0x68.
W	0x0C1	[7:0]	0x69 or 0x49	Set DLL search mode. If $f_{DAC}$ is < 4.5 GHz, set this register to 0x49. Otherwise, set this register to 0x69.
W	0x0C7	[7:0]	0x01	Enable DLL read status.
R	0x0C3	0	0b1	Ensure DLL is locked by reading back a value of 1 for Bit 0 of this register.

Table 54. Calibration

R/W	Register	Bits	Value	Description
W	0x050	[7:0]	0x2A	Optimized calibration setting register write.
W	0x061	[7:0]	0x68	Required calibration control register write.
W	0x051	[7:0]	0x82	Optimized calibration setting register write.
W	0x051	[7:0]	0x83	Required calibration control register write.
W	0x081	[7:0]	0x03	Required calibration control register write.

Table 55. JESD204B Mode Setup

R/W	Register	Bits	Value	Description
W	0x100	[7:0]	0x00	Power up digital datapath clocks when internal clocks are stable.
W	0x110	[5:0]	JESD_MODE	Bit 5 of the JESD_MODE bit field determines whether the device is operating in single link or dual link modes. 0 = single-link mode; 1 = dual-link mode. Bits[4:0] determine the SERDES JESD204B mode of operation chosen from the appropriate single-link or dual-link modes in Table 15 or Table 16.
W	0x111	[7:4]	DP_INTERP_MODE	Main datapath interpolation mode. The valid interpolation options for this control is based on the JESD_MODE selected in Register 0x110. Bit 7 of Register 0x110 equals 1 if the JESD_MODE, DP_INTERP_MODE, and CH_INTERP_MODE settings are not a valid combination.
		[3:0]	CH_INTERP_MODE	Channel datapath interpolation mode. The valid interpolation options for this control is based on the JESD_MODE selected in Register 0x110. Bit 7 of Register 0x110 equals 1 if the JESD_MODE, DP_INTERP_MODE, and CH_INTERP_MODE settings are not a valid combination.
W	0x084	6	SYSREF_INPUTMODE	SYSREF± signal input mode selection. 0b0 = ac-coupled. 0b1 = dc-coupled.
		0	SYSREF_PD	If using Subclass 0, this bit can be set to 1 to power down the SYSREF± receiver. If using Subclass 1, keep at the default of 0.
W	0x312	[7:4]		Set SYNCOUTx± error duration, depending on the selected mode.

R/W	Register	Bits	Value	Description
W	0x300	3	LINK_MODE	Corresponds to the mode selection made in Register 0x110. 0b0 = single-link mode. 0b1 = dual-link mode.
		2	0b0	Select Link 0 for setup. This bit selects the link QBD being paged. 0b0 = Link 0 (QBD0). 0b1 = Link 1 (QBD1).
		[1:0]	LINK_EN	Enables the links. 0b01 = single-link mode. 0b11 = dual link mode.
W	0x475	[7:0]	0x09	Soft reset the JESD204B quad-byte deframer.
W	0x453	7	SCR	Set scrambling option for SERDES data. 0 = disable scrambling. 1 = enable scrambling.
		[4:0]	L-1	Write the L value (in n – 1 notation) for the selected JESD_MODE.
W	0x458	[7:5]	SUBCLASSV	For Subclass 0, set this bit to 0. For Subclass 1, set this bit to 1.
		[4:0]	NP_1	Write the NP value (in n – 1 notation) for the selected JESD_MODE.
W	0x475	[7:0]	0x01	Bring the JESD204B quad-byte deframer out of reset.
W	0x300			If running in dual link mode, repeat writes for Link 1 as follows. If running in single-link mode, skip the remaining steps in this table.
		3	LINK_MODE	Corresponds to the mode selection made in Register 0x110. 0b0 = single-link mode. 0b1 = dual link mode.
		2	0b1	Select Link 1 for setup. This bit selects which link QBD is being paged. 0b0 = Link 0 (QBD0). 0b1 = Link 1 (QBD1).
		[1:0]	0b00	Keep links disabled until end of routine.
W	0x475	[7:0]	0x09	Soft reset the JESD204B quad-byte deframer.
W	0x453	7	SCR	Set scrambling option for SERDES data. 0 = disable scrambling. 1 = enable scrambling.
W	0x458	[4:0]	L_1	Write the L value (in n – 1 notation) for the selected JESD_MODE.
		[7:5]	SUBCLASSV	For Subclass 0, set this bit to 0. For Subclass 1, set this bit to 1.
		[4:0]	NP_1	Write the NP value (in n – 1 notation) for the selected JESD_MODE.
W	0x475	[7:0]	0x01	Bring the JESD204B quad-byte deframer out of reset.

Table 56 lists optional registers to configure the channel datapaths if they are being configured for a specific application. If the channel datapaths are bypassed (CH\_INTERP\_MODE = 1 for 1× channel interpolation), Table 56 can be skipped in the start-up sequence.

**Table 56. Channel Datapath Setup: Digital Gain and Channel NCOs**

R/W	Register	Bits	Value	Description
W	0x008	[5:0]		CHANNEL_PAGE. Select the channels to be programmed at the same time (or repeat this block for each channel to independently program values). Bit x of this control corresponds to the Channel x datapath.
W	0x146	[7:0]		CHNL_GAIN[7:0]. Write LSBs of channel digital gain. Configure digital gain for selected channels in Paging Register 0x008. Calculation: CHNL_GAIN = $2^{11} \times 10(\text{dB Gain}/20)$ where dB Gain is the gain value in dB for the channel gain desired.
W	0x147	[7:0]		CHNL_GAIN[11:8]. Write MSBs of channel digital gain. Calculations shown in Register 0x146.
W	0x130	6		Enable NCO for selected channels in paging Register 0x008. 0b0 = disable NCO. 0b1 = enable NCO.
		2		Enable NCO modulus for selected channels in paging Register 0x008. 0b0 = disable NCO modulus. 0b1 = enable NCO modulus.
		1		Select sideband from modulation result. 0b0 = upper sideband. 0b1 = lower sideband (spectral flip).
		0		If dc test mode or NCO test mode is desired, set this bit to 1 to enable the test tone generation. Otherwise, set this bit to the default value of 0. Integer NCO mode calculation: DDSC_FTW = $(f_{\text{CARRIER}}/f_{\text{NCO}}) \times 2^{48}$ , where $f_{\text{NCO}} = f_{\text{DATA}}/\text{CH\_INTERP\_MODE}$ .
W	0x132	[7:0]		Write DDSC_FTW[7:0].
W	0x133	[7:0]		Write DDSC_FTW[15:8].
W	0x134	[7:0]		Write DDSC_FTW[23:16].
W	0x135	[7:0]		Write DDSC_FTW[31:24].
W	0x136	[7:0]		Write DDSC_FTW[39:32].
W	0x137	[7:0]		Write DDSC_FTW[47:40].
W	0x138	[7:0]		Write DDSC_NCO_PHASE_OFFSET[7:0]. Calculation: DDSC_NCO_PHASE_OFFSET = $(\text{Degrees Offset}/180) \times 2^{15}$ .
W	0x139	[7:0]		Write DDSC_NCO_PHASE_OFFSET[15:8]. If using NCO modulus mode, also program modulus parameters. If not, skip this section. For modulus NCO mode: $(f_{\text{CARRIER}}/f_{\text{NCO}}) = (X + (A/B))/2^{48}$ where DDSC_ACC_DELTA = A, DDSC_ACC_MODULUS = B, and DDSC_FTW = X.
W	0x13A	[7:0]		Write DDSC_ACC_MODULUS[7:0].
W	0x13B	[7:0]		Write DDSC_ACC_MODULUS[15:8].
W	0x13C	[7:0]		Write DDSC_ACC_MODULUS[23:16].
W	0x13D	[7:0]		Write DDSC_ACC_MODULUS[31:24].
W	0x13E	[7:0]		Write DDSC_ACC_MODULUS[39:32].
W	0x13F	[7:0]		Write DDSC_ACC_MODULUS[47:40].
W	0x140	[7:0]		Write DDSC_ACC_DELTA[7:0].
W	0x141	[7:0]		Write DDSC_ACC_DELTA[15:8].
W	0x142	[7:0]		Write DDSC_ACC_DELTA[23:16].
W	0x143	[7:0]		Write DDSC_ACC_DELTA[31:24].
W	0x144	[7:0]		Write DDSC_ACC_DELTA[39:32].
W	0x145	[7:0]		Write DDSC_ACC_DELTA[47:40].
W	0x131	0	0b1	Update all NCO phase and FTW words.

Table 57 lists optional registers to configure the main DAC datapaths if they are being configured for a specific application. If the main DAC datapaths are bypassed (DP\_INTERP\_MODE = 1 for 1× channel interpolation), Table 57 can be skipped in the start-up sequence.

**Table 57. Main DAC Datapath Setup: PA Protect and Main NCOs**

R/W	Register	Bits	Value	Description
W	0x008	[7:6]		MAINDAC_PAGE. Select the main DAC datapath to be programmed at the same time (or repeat this block for each DAC datapath to independently program values). Bit x of this control corresponds to the DAC x datapath.
W	0x112	3		Enable NCO for selected channels in paging Register 0x008. 0b0 = disable NCO. 0b1 = enable NCO.
		2		Enable NCO modulus for selected channels in paging Register 0x008. 0b0 = disable NCO modulus. 0b1 = enable NCO modulus.
		1		Select sideband from modulation result. 0b0 = upper sideband. 0b1 = lower sideband (spectral flip).
		0		Set this bit to 0. Integer NCO mode calculation: $DDSM\_FTW = (f_{CARRIER}/f_{DAC}) \times 2^{48}$ .
W	0x114	[7:0]		Write DDSM_FTW[7:0].
W	0x115	[7:0]		Write DDSM_FTW[15:8].
W	0x116	[7:0]		Write DDSM_FTW[23:16].
W	0x117	[7:0]		Write DDSM_FTW[31:24].
W	0x118	[7:0]		Write DDSM_FTW[39:32].
W	0x119	[7:0]		Write DDSM_FTW[47:40].
W	0x11C	[7:0]		Write DDSM_NCO_PHASE_OFFSET[7:0]. Calculation: $DDSM\_NCO\_PHASE\_OFFSET = (degrees\ offset/180) \times 2^{15}$ .
W	0x11D	[7:0]		Write DDSM_NCO_PHASE_OFFSET[15:8]. If using NCO modulus mode, also program modulus parameters. If not, skip this section. For modulus NCO mode: $(f_{CARRIER}/f_{DAC}) = (X + (A/B))/2^{48}$ , where $DDSM\_ACC\_DELTA = A$ , $DDSM\_ACC\_MODULUS = B$ , and $DDSM\_FTW = X$ .
W	0x124	[7:0]		Write DDSM_ACC_MODULUS[7:0].
W	0x125	[7:0]		Write DDSM_ACC_MODULUS[15:8].
W	0x126	[7:0]		Write DDSM_ACC_MODULUS[23:16].
W	0x127	[7:0]		Write DDSM_ACC_MODULUS[31:24].
W	0x128	[7:0]		Write DDSM_ACC_MODULUS[39:32].
W	0x129	[7:0]		Write DDSM_ACC_MODULUS[47:40].
W	0x12A	[7:0]		Write DDSM_ACC_DELTA[7:0].
W	0x12B	[7:0]		Write DDSM_ACC_DELTA[15:8].
W	0x12C	[7:0]		Write DDSM_ACC_DELTA[23:16].
W	0x12D	[7:0]		Write DDSM_ACC_DELTA[31:24].
W	0x12E	[7:0]		Write DDSM_ACC_DELTA[39:32].
W	0x12F	[7:0]		Write DDSM_ACC_DELTA[47:40].
W	0x113	0	0b1	Update all NCO phase and FTW words.

Table 58. JESD204B SERDES Required Interface Setup

R/W	Register	Bits	Value	Description
W	0x240	[7:0]	0xAA or 0xFF	EQ settings determined by amount of insertion loss according to Table 22. For insertion loss $\leq$ 11 dB, set to 0xAA; otherwise, set to 0xFF.
W	0x241	[7:0]	0xAA or 0xFF	EQ settings determined by amount of insertion loss according to Table 22. For insertion loss $\leq$ 11 dB, set to 0xAA; otherwise, set to 0xFF.
W	0x242	[7:0]	0x55 or 0xFF	EQ settings determined by amount of insertion loss according to Table 22. For insertion loss $\leq$ 11 dB, set to 0x55; otherwise, set to 0xFF.
W	0x243	[7:0]	0x55 or 0xFF	EQ settings determined by amount of insertion loss according to Table 22. For insertion loss $\leq$ 11 dB, set to 0x55; otherwise, set to 0xFF.
W	0x244	[7:0]	0x1F	EQ settings.
W	0x245	[7:0]	0x1F	EQ settings.
W	0x246	[7:0]	0x1F	EQ settings.
W	0x247	[7:0]	0x1F	EQ settings.
W	0x248	[7:0]	0x1F	EQ settings.
W	0x249	[7:0]	0x1F	EQ settings.
W	0x24A	[7:0]	0x1F	EQ settings.
W	0x24B	[7:0]	0x1F	EQ settings.
W	0x201	[7:0]		Power down unused PHYs. Bit x corresponds to SERDIN $\pm$ pin power-down.
W	0x203	1	0b0	If in single-link mode, set to 0x01. If in dual-link mode and using both SYNCOUT $\pm$ signals, set to 0x00. Power up SYNCOUT $\pm$ driver by setting this bit to 0.
		0		Power up SYNCOUT $\pm$ driver by setting this bit to 0 if using dual link and both SYNCOUT $\pm$ signals.
W	0x253	[7:0]	0x01	Set SYNCOUT $\pm$ to be LVDS output. For CMOS output on SYNCOUT $\pm$ , set Bit 0 to 0.
W	0x254	[7:0]	0x01	Set SYNCOUT $\pm$ to be LVDS output. For CMOS output on SYNCOUT $\pm$ , set Bit 0 to 0.
W	0x210	[7:0]	0x16	SERDES required register write.
W	0x216	[7:0]	0x05	SERDES required register write.
W	0x212	[7:0]	0xFF	SERDES required register write.
W	0x212	[7:0]	0x00	SERDES required register write.
W	0x210	[7:0]	0x87	SERDES required register write.
W	0x216	[7:0]	0x11	SERDES required register write.
W	0x213	[7:0]	0x01	SERDES required register write.
W	0x213	[7:0]	0x00	SERDES required register write.
W	0x200	[7:0]	0x00	Power up the SERDES circuitry blocks.
	Pause			Wait 100 ms.
W	0x210	[7:0]	0x86	SERDES required register write.
W	0x216	[7:0]	0x40	SERDES required register write.
W	0x213	[7:0]	0x01	SERDES required register write.
W	0x213	[7:0]	0x00	SERDES required register write.
W	0x210	[7:0]	0x86	SERDES required register write.
W	0x216	[7:0]	0x00	SERDES required register write.
W	0x213	[7:0]	0x01	SERDES required register write.
W	0x213	[7:0]	0x00	SERDES required register write.
W	0x210	[7:0]	0x87	SERDES required register write.
W	0x216	[7:0]	0x01	SERDES required register write.
W	0x213	[7:0]	0x01	SERDES required register write.
W	0x213	[7:0]	0x00	SERDES required register write.
W	0x280	[7:0]	0x05	SERDES required register write.
W	0x280	[7:0]	0x01	Start up SERDES PLL circuitry blocks and initiate SERDES PLL calibration.
R	0x281	0	0b1	Ensure Bit 0 of this register reads back 1 to indicate the SERDES PLL is locked.

Crossbar mapping writes the SERDIN<sub>x</sub> input pin that is the source for each given logical lane in these registers. A value of x corresponds to mapping data from the SERDIN<sub>x±</sub> pin to the logical lane of the control bit field. The values in Table 59 vary with different PCB layout routing.

**Table 59. Transport Layer Setup, Synchronization, and Enable Links**

R/W	Register	Bits	Value	Description
W	0x308	[7:0]		Crossbar setup. Program the physical lane value that is providing data (the source) for each of the logical lanes. [5:3] = Logical Lane 1 source, [2:0] = Logical Lane 0 source.
W	0x309	[7:0]		[5:3] = Logical Lane 3 source, [2:0] = Logical Lane 2 source.
W	0x30A	[7:0]		[5:3] = Logical Lane 5 source, [2:0] = Logical Lane 4 source.
W	0x30B	[7:0]		[5:3] = Logical Lane 7 source, [2:0] = Logical Lane 6 source.
W	0x306	[7:0]	0x0C	If operating in Subclass 0, this register write is not needed.
W	0x307	[7:0]	0x0C	If operating in Subclass 0, this register write is not needed.
W	0x304	[7:0]		If operating in Subclass 0, this register write is not needed. For Subclass 1, these values must be determined by following one of the deterministic latency methods (with or without known delays), as mentioned in the Link Delay section.
W	0x305	[7:0]		If operating in Subclass 0, this register write is not needed. For Subclass 1, these values must be determined by following one of the deterministic latency methods (with or without known delays), as mentioned in the Link Delay section.
W	0x03B	[7:0]	0xF1	Enable the sync logic, and set the rotation mode to reset the synchronization logic upon a sync reset trigger.
W	0x03A	[7:0]	0x02	Set up sync for one-shot sync mode.
	SYSREF <sub>±</sub>			If operating in Subclass 1, send SYSREF <sub>±</sub> pulse edges to the device for synchronization alignment.
W	0x300	3	LINK_MODE	Corresponds to the mode selection made in Register 0x110. 0b0 = single-link mode. 0b1 = dual-link mode.
		2	0b0	Select Link 0 for setup. This bit selects which link QBD is being paged. 0b0 = Link 0 (QBD0). 0b1 = Link 1 (QBD1).
		[1:0]	LINK_EN	Enables the links. 0b01 = single-link mode 0b11 = dual-link mode.

**Table 60. Cleanup Registers**

R/W	Register	Bits	Value	Description
W	0x085	[7:0]	0x13	Set to the default register value.
W	0x1DE	[7:0]	0x00	Disable analog SPI. To debug and continue readback capability, write 0x03.
W	0x008	[7:0]	0xC0	Page all main DACs for TXEN control update.
W	0x596	[7:0]	0x0C	SPI turn on TXEN <sub>x</sub> feature.

## REGISTER SUMMARY

Table 61. Register Summary

Reg.	Name	Bit 7	Bit 6	Bit 5	Bit 4	Bit 3	Bit 2	Bit 1	Bit 0	Reset	RW	
0x000	SPI_INTFCONFA	SOFTRESET_M	LSBFIRST_M	ADDRINC_M	SDOACTIVE_M	SDOACTIVE	ADDRINC	LSBFIRST	SOFTRESET	0x00	R/W	
0x001	SPI_INTFCONFB	SINGLEINS	CSSTALL	RESERVED						0x00	R/W	
0x003	SPI_CHIPTYPE	CHIP_TYPE								0x04	R	
0x004	SPI_PRODIDL	PROD_ID[7:0]								0x72	R	
0x005	SPI_PRODIDH	PROD_ID[15:8]								0x91	R	
0x006	SPI_CHIPGRADE	PROD_GRADE				DEV_REVISION				0x04	R	
0x008	SPI_PAGEINDX	MAINDAC_PAGE			CHANNEL_PAGE					0xFF	R/W	
0x00A	SPI_SCRATCHPAD	SCRATCHPAD								0x00	R/W	
0x010	CHIP_ID_L	CHIP_ID[7:0]								0x00	R	
0x011	CHIP_ID_M1	CHIP_ID[15:8]								0x00	R	
0x012	CHIP_ID_M2	CHIP_ID[23:16]								0x00	R	
0x013	CHIP_ID_H	CHIP_ID[31:24]								0x00	R	
0x020	IRQ_ENABLE	RESERVED			EN_SYSREF_JITTER	EN_DATA_READY	EN_LANE_FIFO	EN_PRBSQ	EN_PRBSI	0x00	R/W	
0x021	IRQ_ENABLE0	RESERVED				EN_DAC0_CAL_DONE	RESERVED		EN_PAERRO	0x00	R/W	
0x022	IRQ_ENABLE1	RESERVED				EN_DAC1_CAL_DONE	RESERVED		EN_PAERR1	0x00	R/W	
0x023	IRQ_ENABLE2	RESERVED		EN_DLL_LOST	EN_DLL_LOCK	RESERVED		EN_PLL_LOST	EN_PLL_LOCK	0x00	R/W	
0x024	IRQ_STATUS	RESERVED			IRQ_SYSREF_JITTER	IRQ_DATA_READY	IRQ_LANE_FIFO	IRQ_PRBSQ	IRQ_PRBSI	0x00	R/W	
0x025	IRQ_STATUS0	RESERVED				IRQ_DAC0_CAL_DONE	RESERVED		IRQ_PAERRO	0x00	R/W	
0x026	IRQ_STATUS1	RESERVED				IRQ_DAC1_CAL_DONE	RESERVED		IRQ_PAERR1	0x00	R/W	
0x027	IRQ_STATUS2	RESERVED		IRQ_DLL_LOST	IRQ_DLL_LOCK	RESERVED		IRQ_PLL_LOST	IRQ_PLL_LOCK	0x00	R/W	
0x028	IRQ_OUTPUT_MUX	RESERVED			MUX_SYSREF_JITTER	MUX_DATA_READY	MUX_LANE_FIFO	MUX_PRBSQ	MUX_PRBSI	0x00	R/W	
0x029	IRQ_OUTPUT_MUX0	RESERVED				MUX_DAC0_CAL_DONE	RESERVED		MUX_PAERRO	0x00	R/W	
0x02A	IRQ_OUTPUT_MUX1	RESERVED				MUX_DAC1_CAL_DONE	RESERVED		MUX_PAERR1	0x00	R/W	
0x02B	IRQ_OUTPUT_MUX2	RESERVED		MUX_DLL_LOST	MUX_DLL_LOCK	RESERVED		MUX_PLL_LOST	MUX_PLL_LOCK	0x00	R/W	
0x02C	IRQ_STATUS_ALL	RESERVED							IRQ_STATUS_ALL	0x00	R/W	
0x036	SYSREF_COUNT	SYSREF_COUNT								0x00	R/W	
0x039	SYSREF_ERR_WINDOW	RESERVED	SYSREF_ERR_WINDOW								0x00	R/W
0x03A	SYSREF_MODE	RESERVED			SYNC_ROTATION_DONE	RESERVED		SYSREF_MODE_ONESHOT	RESERVED	0x10	R/W	
0x03B	ROTATION_MODE	SYNCLGIC_EN	RESERVED	PERIODIC_RST_EN	NCORST_AFTER_ROT_EN	RESERVED		ROTATION_MODE		0xB0	R/W	
0x03F	TX_ENABLE	RESERVED			TXEN_DATAPATH_DAC1	TXEN_DATAPATH_DAC0	RESERVED				0x00	R/W
0x050	CAL_CLK_DIV	RESERVED				CAL_CLK_DIV				0x28	R/W	
0x051	CAL_CTRL	CAL_CTRL0	RESERVED				CAL_CTRL1		CAL_START	0x82	R/W	
0x052	CAL_STAT	RESERVED					CAL_ACTIVE	CAL_FAIL_SEARCH	CAL_FINISH	0x00	R/W	
0x05A	FSC1	FSC_CTRL[7:0]								0x28	R/W	
0x061	CAL_DEBUG0	RESERVED	CAL_CTRL2	CAL_CTRL3	RESERVED	CAL_CTRL4	RESERVED				0x60	R/W
0x081	CLK_CTRL	RESERVED						CAL_CLK_PD1	CAL_CLK_PD0	0x00	R/W	
0x083	NVM_CTRL0	NVM_CTRL0A	RESERVED					NVM_CTRL0B		0x02	R/W	
0x084	SYSREF_CTRL	RESERVED	SYSREF_INPUTMODE	RESERVED					SYSREF_PD	0x00	R/W	

Reg.	Name	Bit 7	Bit 6	Bit 5	Bit 4	Bit 3	Bit 2	Bit 1	Bit 0	Reset	RW		
0x085	NVM_CTRL1	RESERVED	NVM_CTRL1A			RESERVED		NVM_CTRL1B	NVM_CTRL1C	0x13	R/W		
0x08D	ADC_CLK_CTRL0	RESERVED			CLKOUT_SWING						0x00	R/W	
0x08F	ADC_CLK_CTRL2	RESERVED							PD_CLKOUT_DRIVER	0x00	R/W		
0x090	DAC_POWERDOWN	RESERVED						DAC_PD1	DAC_PD0	0x03	R/W		
0x091	ACLK_CTRL	RESERVED							ACLK_POWERDOWN	0x01	R/W		
0x094	PLL_CLK_DIV	RESERVED						PLL_VCO_DIV3_EN	PLL_VCO_DIV2_EN	0x00	R/W		
0x095	PLL_BYPASS	RESERVED							PLL_BYPASS	0x00	R/W		
0x09A	NVM_CTRL	PD_BGR	RESERVED									0x00	R/W
0x0C0	DELAY_LINE_PD	RESERVED		DLL_CTRL0B	DLL_CTRL0A	RESERVED			DLL_PD	0x31	R/W		
0x0C1	DLL_CTRL0	DLL_CTRL1C		DLL_CTRL1B	DLL_CTRL1A		RESERVED		DLL_ENABLE	0x70	R/W		
0x0C3	DLL_STATUS	RESERVED							DLL_LOCK	0x00	R/W		
0x0C7	DLL_READ	RESERVED							DLL_READ_EN	0x00	R/W		
0x0CC	DLL_FINE_DELAY0	RESERVED			DLL_FINE_DELAY0						0x00	R/W	
0x0CD	DLL_FINE_DELAY1	RESERVED			DLL_FINE_DELAY1						0x00	R/W	
0x0DB	DLL_UPDATE	RESERVED							DLL_DELAY_UPDATE	0x00	R/W		
0x0FF	MOD_SWITCH_DEBUG	RESERVED						CMPLEX_MOD_DIV2_DISABLE	RESERVED	0x00	R/W		
0x100	DIG_RESET	RESERVED							DIG_DATAPATH_PD	0x01	R/W		
0x110	JESD_MODE	MODE_NOT_IN_TABLE	COM_SYNC	JESD_MODE							0x20	R/W	
0x111	INTRP_MODE	DP_INTERP_MODE				CH_INTERP_MODE				0x84	R/W		
0x112	DDSM_DATAPATH_CFG	RESERVED	EN_CMPLEX_MOD	DDSM_MODE		DDSM_NCO_EN	DDSM_MODULUS_EN	DDSM_SEL_SIDE BAND	EN_SYNC_ALL_CHNL_NCO_RESETS	0x01	R/W		
0x113	DDSM_FTW_UPDATE	RESERVED	DDSM_FTW_REQ_MODE			RESERVED	DDSM_FTW_LOAD_SYSREF	DDSM_FTW_LOAD_ACK	DDSM_FTW_LOAD_REQ	0x00	R/W		
0x114	DDSM_FTW0	DDSM_FTW[7:0]								0x00	R/W		
0x115	DDSM_FTW1	DDSM_FTW[15:8]								0x00	R/W		
0x116	DDSM_FTW2	DDSM_FTW[23:16]								0x00	R/W		
0x117	DDSM_FTW3	DDSM_FTW[31:24]								0x00	R/W		
0x118	DDSM_FTW4	DDSM_FTW[39:32]								0x00	R/W		
0x119	DDSM_FTW5	DDSM_FTW[47:40]								0x00	R/W		
0x11C	DDSM_PHASE_OFFSET0	DDSM_NCO_PHASE_OFFSET[7:0]								0x00	R/W		
0x11D	DDSM_PHASE_OFFSET1	DDSM_NCO_PHASE_OFFSET[15:8]								0x00	R/W		
0x124	DDSM_ACC_MODULUS0	DDSM_ACC_MODULUS[7:0]								0x00	R/W		
0x125	DDSM_ACC_MODULUS1	DDSM_ACC_MODULUS[15:8]								0x00	R/W		
0x126	DDSM_ACC_MODULUS2	DDSM_ACC_MODULUS[23:16]								0x00	R/W		
0x127	DDSM_ACC_MODULUS3	DDSM_ACC_MODULUS[31:24]								0x00	R/W		
0x128	DDSM_ACC_MODULUS4	DDSM_ACC_MODULUS[39:32]								0x00	R/W		
0x129	DDSM_ACC_MODULUS5	DDSM_ACC_MODULUS[47:40]								0x00	R/W		
0x12A	DDSM_ACC_DELTA0	DDSM_ACC_DELTA[7:0]								0x00	R/W		

Reg.	Name	Bit 7	Bit 6	Bit 5	Bit 4	Bit 3	Bit 2	Bit 1	Bit 0	Reset	RW		
0x12B	DDSM_ACC_DELTA1	DDSM_ACC_DELTA[15:8]								0x00	R/W		
0x12C	DDSM_ACC_DELTA2	DDSM_ACC_DELTA[23:16]								0x00	R/W		
0x12D	DDSM_ACC_DELTA3	DDSM_ACC_DELTA[31:24]								0x00	R/W		
0x12E	DDSM_ACC_DELTA4	DDSM_ACC_DELTA[39:32]								0x00	R/W		
0x12F	DDSM_ACC_DELTA5	DDSM_ACC_DELTA[47:40]								0x00	R/W		
0x130	DDSC_DATAPATH_CFG	RESERVED	DDSC_NCO_EN	RESERVED			DDSC_MODULUS_EN	DDSC_SEL_SIDE BAND	DDSC_EN_DC_INPUT	0x00	R/W		
0x131	DDSC_FTW_UPDATE	RESERVED					DDSC_FTW_LOAD_SYSREF	DDSC_FTW_LOAD_ACK	DDSC_FTW_LOAD_REQ	0x00	R/W		
0x132	DDSC_FTW0	DDSC_FTW[7:0]								0x00	R/W		
0x133	DDSC_FTW1	DDSC_FTW[15:8]								0x00	R/W		
0x134	DDSC_FTW2	DDSC_FTW[23:16]								0x00	R/W		
0x135	DDSC_FTW3	DDSC_FTW[31:24]								0x00	R/W		
0x136	DDSC_FTW4	DDSC_FTW[39:32]								0x00	R/W		
0x137	DDSC_FTW5	DDSC_FTW[47:40]								0x00	R/W		
0x138	DDSC_PHASE_OFFSET0	DDSC_NCO_PHASE_OFFSET[7:0]								0x00	R/W		
0x139	DDSC_PHASE_OFFSET1	DDSC_NCO_PHASE_OFFSET[15:8]								0x00	R/W		
0x13A	DDSC_ACC_MODULUS0	DDSC_ACC_MODULUS[7:0]								0x00	R/W		
0x13B	DDSC_ACC_MODULUS1	DDSC_ACC_MODULUS[15:8]								0x00	R/W		
0x13C	DDSC_ACC_MODULUS2	DDSC_ACC_MODULUS[23:16]								0x00	R/W		
0x13D	DDSC_ACC_MODULUS3	DDSC_ACC_MODULUS[31:24]								0x00	R/W		
0x13E	DDSC_ACC_MODULUS4	DDSC_ACC_MODULUS[39:32]								0x00	R/W		
0x13F	DDSC_ACC_MODULUS5	DDSC_ACC_MODULUS[47:40]								0x00	R/W		
0x140	DDSC_ACC_DELTA0	DDSC_ACC_DELTA[7:0]								0x00	R/W		
0x141	DDSC_ACC_DELTA1	DDSC_ACC_DELTA[15:8]								0x00	R/W		
0x142	DDSC_ACC_DELTA2	DDSC_ACC_DELTA[23:16]								0x00	R/W		
0x143	DDSC_ACC_DELTA3	DDSC_ACC_DELTA[31:24]								0x00	R/W		
0x144	DDSC_ACC_DELTA4	DDSC_ACC_DELTA[39:32]								0x00	R/W		
0x145	DDSC_ACC_DELTA5	DDSC_ACC_DELTA[47:40]								0x00	R/W		
0x146	CHNL_GAIN0	CHNL_GAIN[7:0]								0x00	R/W		
0x147	CHNL_GAIN1	RESERVED				CHNL_GAIN[11:8]				0x08	R/W		
0x148	DC_CAL_TONE0	DC_TEST_INPUT_AMPLITUDE[7:0]								0x00	R/W		
0x149	DC_CAL_TONE1	DC_TEST_INPUT_AMPLITUDE[15:8]								0x00	R/W		
0x14B	PRBS	PRBS_GOOD_Q	PRBS_GOOD_I	RESERVED	PRBS_INV_Q	PRBS_INV_I	PRBS_MODE	PRBS_RESET	PRBS_EN	0x10	R/W		
0x14C	PRBS_ERROR_I	PRBS_COUNT_I								0x00	R		
0x14D	PRBS_ERROR_Q	PRBS_COUNT_Q								0x00	R		
0x14E	PRBS_CHANSEL	RESERVED					PRBS_CHANSEL					0x07	R/W
0x151	DECODE_MODE	RESERVED			MSB_SHUFFLE_EN	RESERVED					0x00	R/W	
0x1DE	SPI_ENABLE	RESERVED						SPI_EN1	SPI_EN0	0x03	R/W		
0x1E2	DDSM_CAL_FTW0	DDSM_CAL_FTW[7:0]								0x00	R/W		
0x1E3	DDSM_CAL_FTW1	DDSM_CAL_FTW[15:8]								0x00	R/W		
0x1E4	DDSM_CAL_FTW2	DDSM_CAL_FTW[23:16]								0x00	R/W		

Reg.	Name	Bit 7	Bit 6	Bit 5	Bit 4	Bit 3	Bit 2	Bit 1	Bit 0	Reset	RW	
0x1E5	DDSM_CAL_FT_W3	DDSM_CAL_FT_W[31:24]								0x00	R/W	
0x1E6	DDSM_CAL_MODE_DEF	RESERVED					DDSM_EN_CAL_ACC	DDSM_EN_CAL_DC_INPUT	DDSM_EN_CAL_FREQ_TUNE	0x00	R/W	
0x1E7	DATAPATH_NCO_SYNC_CFG	RESERVED						ALL_NCO_SYNC_ACK	START_NCO_SYNC	0x00	R/W	
0x200	MASTER_PD	RESERVED							SERDES_MASTER_PD	0x01	R/W	
0x201	PHY_PD	PHY_PD										
0x203	GENERIC_PD	RESERVED						PD_SYNCOUT0	PD_SYNCOUT1	0x01	R/W	
0x206	CDR_RESET	RESERVED							CDR_PHY_RESET	0x00	R/W	
0x210	CBUS_ADDR	SERDES_CBUS_ADDR										
0x212	CBUS_WRSTROBE_PHY	SERDES_CBUS_WRO										
0x213	CBUS_WRSTROBE_OTHER	RESERVED							SERDES_CBUS_WR1	0x00	R/W	
0x216	CBUS_WDATA	SERDES_CBUS_DATA										
0x234	CDR_BITINVERSE	SEL_IF_PARDATAINV_DES_RC_CH										
0x240	EQ_BOOST_PHY_3_0	EQ_BOOST_PHY3	EQ_BOOST_PHY2			EQ_BOOST_PHY1		EQ_BOOST_PHY0			0xFF	R/W
0x241	EQ_BOOST_PHY_7_4	EQ_BOOST_PHY7	EQ_BOOST_PHY6			EQ_BOOST_PHY5		EQ_BOOST_PHY4			0xFF	R/W
0x242	EQ_GAIN_PHY_3_0	EQ_GAIN_PHY3	EQ_GAIN_PHY2			EQ_GAIN_PHY1		EQ_GAIN_PHY0			0xFF	R/W
0x243	EQ_GAIN_PHY_7_4	EQ_GAIN_PHY7	EQ_GAIN_PHY6			EQ_GAIN_PHY5		EQ_GAIN_PHY4			0xFF	R/W
0x244	EQ_FB_PHY_0	RESERVED			EQ_PHY_0				0x19	R/W		
0x245	EQ_FB_PHY_1	RESERVED			EQ_PHY1				0x19	R/W		
0x246	EQ_FB_PHY_2	RESERVED			EQ_PHY2				0x19	R/W		
0x247	EQ_FB_PHY_3	RESERVED			EQ_PHY3				0x19	R/W		
0x248	EQ_FB_PHY_4	RESERVED			EQ_PHY4				0x19	R/W		
0x249	EQ_FB_PHY_5	RESERVED			EQ_PHY5				0x19	R/W		
0x24A	EQ_FB_PHY_6	RESERVED			EQ_PHY6				0x19	R/W		
0x24B	EQ_FB_PHY_7	RESERVED			EQ_PHY7				0x19	R/W		
0x250	LBT_REG_CNTRL_0	EN_LBT_DES_RC_CH										
0x251	LBT_REG_CNTRL_1	RESERVED						EN_LBT_HALFRATE_DES_RC	INIT_LBT_SYNC_DES_RC	0x02	R/W	
0x253	SYNCOUT0_CTRL	RESERVED							SEL_SYNCOUT0_MODE	0x00	R/W	
0x254	SYNCOUT1_CTRL	RESERVED							SEL_SYNCOUT1_MODE	0x00	R/W	
0x280	PLL_ENABLE_CTRL	RESERVED					LOLSTICKY-CLEAR_LCPLL_RC	LDSYNTH_LCPLL_RC	SERDES_PLL_STARTUP	0x01	R/W	
0x281	PLL_STATUS	RESERVED							SERDES_PLL_LOCK	0x00	R	
0x300	GENERAL_JRX_CTRL_0	RESERVED				LINK_MODE	LINK_PAGE	LINK_EN			0x00	R/W
0x302	DYN_LINK_LATENCY_0	RESERVED	DYN_LINK_LATENCY_0									
0x303	DYN_LINK_LATENCY_1	RESERVED	DYN_LINK_LATENCY_1									
0x304	LMFC_DELAY_0	RESERVED	LMFC_DELAY_0									
0x305	LMFC_DELAY_1	RESERVED	LMFC_DELAY_1									
0x306	LMFC_VAR_0	RESERVED	LMFC_VAR_0									
0x307	LMFC_VAR_1	RESERVED	LMFC_VAR_1									
0x308	XBAR_LN_0_1	RESERVED	LOGICAL_LANE1_SRC				LOGICAL_LANE0_SRC				0x08	R/W
0x309	XBAR_LN_2_3	RESERVED	LOGICAL_LANE3_SRC				LOGICAL_LANE2_SRC				0x1A	R/W
0x30A	XBAR_LN_4_5	RESERVED	LOGICAL_LANE5_SRC				LOGICAL_LANE4_SRC				0x2C	R/W

Reg.	Name	Bit 7	Bit 6	Bit 5	Bit 4	Bit 3	Bit 2	Bit 1	Bit 0	Reset	RW	
0x30B	XBAR_LN_6_7	RESERVED		LOGICAL_LANE7_SRC			LOGICAL_LANE6_SRC			0x3E	R/W	
0x30C	FIFO_STATUS_REG_0	LANE_FIFO_FULL									0x00	R
0x30D	FIFO_STATUS_REG_1	LANE_FIFO_EMPTY									0x00	R
0x311	SYNCOUT_GEN_0	RESERVED				EOMF_MASK_1	EOMF_MASK_0	EOF_MASK_1	EOF_MASK_0	0x00	R/W	
0x312	SYNCOUT_GEN_1	SYNC_ERR_DUR				RESERVED				0x00	R/W	
0x315	PHY_PRBS_TEST_EN	PHY_TEST_EN									0x00	R/W
0x316	PHY_PRBS_TEST_CTRL	RESERVED	PHY_SRC_ERR_CNT			PHY_PRBS_PAT_SEL		PHY_TEST_START	PHY_TEST_RESET	0x00	R/W	
0x317	PHY_PRBS_TEST_THRESHOLD_LOBITS	PHY_PRBS_THRESHOLD_LOBITS									0x00	R/W
0x318	PHY_PRBS_TEST_THRESHOLD_MIDBITS	PHY_PRBS_THRESHOLD_MIDBITS									0x00	R/W
0x319	PHY_PRBS_TEST_THRESHOLD_HIBITS	PHY_PRBS_THRESHOLD_HIBITS									0x00	R/W
0x31A	PHY_PRBS_TEST_ERRCNT_LOBITS	PHY_PRBS_ERR_CNT_LOBITS									0x00	R
0x31B	PHY_PRBS_TEST_ERRCNT_MIDBITS	PHY_PRBS_ERR_CNT_MIDBITS									0x00	R
0x31C	PHY_PRBS_TEST_ERRCNT_HIBITS	PHY_PRBS_ERR_CNT_HIBITS									0x00	R
0x31D	PHY_PRBS_TEST_STATUS	PHY_PRBS_PASS									0xFF	R
0x31E	PHY_DATA_SNAPSHOT_CTRL	RESERVED						PHY_GRAB_MODE	PHY_GRAB_DATA	0x00	R/W	
0x31F	PHY_SNAPSHOT_DATA_BYTE0	PHY_SNAPSHOT_DATA_BYTE0									0x00	R
0x320	PHY_SNAPSHOT_DATA_BYTE1	PHY_SNAPSHOT_DATA_BYTE1									0x00	R
0x321	PHY_SNAPSHOT_DATA_BYTE2	PHY_SNAPSHOT_DATA_BYTE2									0x00	R
0x322	PHY_SNAPSHOT_DATA_BYTE3	PHY_SNAPSHOT_DATA_BYTE3									0x00	R
0x323	PHY_SNAPSHOT_DATA_BYTE4	PHY_SNAPSHOT_DATA_BYTE4									0x00	R
0x32C	SHORT_TPL_TEST_0	SHORT_TPL_SP_SEL			SHORT_TPL_CHAN_SEL		SHORT_TPL_TEST_RESET	SHORT_TPL_TEST_EN	0x00	R/W		
0x32D	SHORT_TPL_TEST_1	SHORT_TPL_REF_SP_LSB									0x00	R/W
0x32E	SHORT_TPL_TEST_2	SHORT_TPL_REF_SP_MSB									0x00	R/W
0x32F	SHORT_TPL_TEST_3	SHORT_TPL_LINK_SEL	SHORT_TPL_IQ_SAMPLE_SEL	RESERVED					SHORT_TPL_FAIL	0x00	R/W	
0x334	JESD_BIT_INVERSE_CTRL	JESD_BIT_INVERSE									0x00	R/W
0x400	DID_REG	DID_RD									0x00	R
0x401	BID_REG	BID_RD									0x00	R
0x402	LIDO_REG	RESERVED	ADJDIR_RD	PHADJ_RD	LL_LID0						0x00	R
0x403	SCR_L_REG	SCR_RD	RESERVED			L_RD_1			0x00	R		
0x404	F_REG	F_RD_1									0x00	R
0x405	K_REG	RESERVED				K_RD_1				0x00	R	
0x406	M_REG	M_RD_1									0x00	R

Reg.	Name	Bit 7	Bit 6	Bit 5	Bit 4	Bit 3	Bit 2	Bit 1	Bit 0	Reset	RW
0x407	CS_N_REG	CS_RD		RESERVED			N_RD_1			0x00	R
0x408	NP_REG	SUBCLASSV_RD					NP_RD_1			0x00	R
0x409	S_REG	JESDV_RD_1					S_RD_1			0x00	R
0x40A	HD_CF_REG	HD_RD	RESERVED				CF_RD			0x00	R
0x40B	RES1_REG					RES1_RD				0x00	R
0x40C	RES2_REG					RES2_RD				0x00	R
0x40D	CHECKSUM0_REG					LL_FCHK0				0x00	R
0x40E	COMPSUM0_REG					LL_FCMP0				0x00	R
0x412	LID1_REG	RESERVED					LL_LID1			0x00	R
0x415	CHECKSUM1_REG					LL_FCHK1				0x00	R
0x416	COMPSUM1_REG					LL_FCMP1				0x00	R
0x41A	LID2_REG	RESERVED					LL_LID2			0x00	R
0x41D	CHECKSUM2_REG					LL_FCHK2				0x00	R
0x41E	COMPSUM2_REG					LL_FCMP2				0x00	R
0x422	LID3_REG	RESERVED					LL_LID3			0x00	R
0x425	CHECKSUM3_REG					LL_FCHK3				0x00	R
0x426	COMPSUM3_REG					LL_FCMP3				0x00	R
0x42A	LID4_REG	RESERVED					LL_LID4			0x00	R
0x42D	CHECKSUM4_REG					LL_FCHK4				0x00	R
0x42E	COMPSUM4_REG					LL_FCMP4				0x00	R
0x432	LID5_REG	RESERVED					LL_LID5			0x00	R
0x435	CHECKSUM5_REG					LL_FCHK5				0x00	R
0x436	COMPSUM5_REG					LL_FCMP5				0x00	R
0x43A	LID6_REG	RESERVED					LL_LID6			0x00	R
0x43D	CHECKSUM6_REG					LL_FCHK6				0x00	R
0x43E	COMPSUM6_REG					LL_FCMP6				0x00	R
0x442	LID7_REG	RESERVED					LL_LID7			0x00	R
0x445	CHECKSUM7_REG					LL_FCHK7				0x00	R
0x446	COMPSUM7_REG					LL_FCMP7				0x00	R
0x450	ILS_DID					DID				0x00	R/W
0x451	ILS_BID					BID				0x00	R/W
0x452	ILS_LID0	RESERVED	ADJDIR	PHADJ			LID0			0x00	R/W
0x453	ILS_SCR_L	SCR	RESERVED				L_1			0x87	R/W
0x454	ILS_F					F_1				0x00	R/W
0x455	ILS_K	RESERVED					K_1			0x1F	R/W
0x456	ILS_M					M_1				0x01	R/W
0x457	ILS_CS_N	CS		RESERVED			N_1			0x0F	R/W
0x458	ILS_NP	SUBCLASSV					NP_1			0x0F	R/W
0x459	ILS_S	JESDV					S_1			0x01	R/W
0x45A	ILS_HD_CF	HD	RESERVED				CF			0x80	R
0x45B	ILS_RES1					RES1				0x00	R/W
0x45C	ILS_RES2					RES2				0x00	R/W
0x45D	ILS_CHECKSUM					FCHK0				0x00	R/W
0x46C	LANE_DESKEW	ILD7	ILD6	ILD5	ILD4	ILD3	ILD2	ILD1	ILD0	0x00	R
0x46D	BAD_DISPARITY	BDE7	BDE6	BDE5	BDE4	BDE3	BDE2	BDE1	BDE0	0x00	R
0x46E	NOT_IN_TABLE	NIT7	NIT6	NIT5	NIT4	NIT3	NIT2	NIT1	NIT0	0x00	R
0x46F	UNEXPECTED_KCHAR	UEK7	UEK6	UEK5	UEK4	UEK3	UEK2	UEK1	UEK0	0x00	R
0x470	CODE_GRP_SYNC	CGS7	CGS6	CGS5	CGS4	CGS3	CGS2	CGS1	CGS0	0x00	R
0x471	FRAME_SYNC	FS7	FS6	FS5	FS4	FS3	FS2	FS1	FS0	0x00	R

Reg.	Name	Bit 7	Bit 6	Bit 5	Bit 4	Bit 3	Bit 2	Bit 1	Bit 0	Reset	RW	
0x472	GOOD_CHECKSUM	CKS7	CKS6	CKS5	CKS4	CKS3	CKS2	CKS1	CKS0	0x00	R	
0x473	INIT_LANE_SYNC	ILS7	ILS6	ILS5	ILS4	ILS3	ILS2	ILS1	ILS0	0x00	R	
0x475	CTRLREG0	RESERVED				SOFTTRST	FORCE_SYNCREQ	RESERVED	REPL_FRM_ENA	0x01	R/W	
0x476	CTRLREG1	RESERVED			QUAL_RDERR	RESERVED			FCHK_N	0x14	R/W	
0x477	CTRLREG2	ILS_MODE	RESERVED	REPDATEST	QUETESTERR	AR_ECNTNTR	RESERVED			0x00	R/W	
0x478	KVAL	KSYNC								0x01	R/W	
0x47C	ERRORTHRES	ETH								0xFF	R/W	
0x47D	SYNC_ASSERT_MASK	RESERVED					SYNC_ASSERT_MASK				0x07	R/W
0x480	ECNT_CTRL0	RESERVED		ECNT_ENA0			ECNT_RST0			0x3F	R/W	
0x481	ECNT_CTRL1	RESERVED		ECNT_ENA1			ECNT_RST1			0x3F	R/W	
0x482	ECNT_CTRL2	RESERVED		ECNT_ENA2			ECNT_RST2			0x3F	R/W	
0x483	ECNT_CTRL3	RESERVED		ECNT_ENA3			ECNT_RST3			0x3F	R/W	
0x484	ECNT_CTRL4	RESERVED		ECNT_ENA4			ECNT_RST4			0x3F	R/W	
0x485	ECNT_CTRL5	RESERVED		ECNT_ENA5			ECNT_RST5			0x3F	R/W	
0x486	ECNT_CTRL6	RESERVED		ECNT_ENA6			ECNT_RST6			0x3F	R/W	
0x487	ECNT_CTRL7	RESERVED		ECNT_ENA7			ECNT_RST7			0x3F	R/W	
0x488	ECNT_TCH0	RESERVED				ECNT_TCH0				0x07	R/W	
0x489	ECNT_TCH1	RESERVED				ECNT_TCH1				0x07	R/W	
0x48A	ECNT_TCH2	RESERVED				ECNT_TCH2				0x07	R/W	
0x48B	ECNT_TCH3	RESERVED				ECNT_TCH3				0x07	R/W	
0x48C	ECNT_TCH4	RESERVED				ECNT_TCH4				0x07	R/W	
0x48D	ECNT_TCH5	RESERVED				ECNT_TCH5				0x07	R/W	
0x48E	ECNT_TCH6	RESERVED				ECNT_TCH6				0x07	R/W	
0x48F	ECNT_TCH7	RESERVED				ECNT_TCH7				0x07	R/W	
0x490	ECNT_STAT0	RESERVED			LANE_ENA0		ECNT_TCR0			0x00	R	
0x491	ECNT_STAT1	RESERVED			LANE_ENA1		ECNT_TCR1			0x00	R	
0x492	ECNT_STAT2	RESERVED			LANE_ENA2		ECNT_TCR2			0x00	R	
0x493	ECNT_STAT3	RESERVED			LANE_ENA3		ECNT_TCR3			0x00	R	
0x494	ECNT_STAT4	RESERVED			LANE_ENA4		ECNT_TCR4			0x00	R	
0x495	ECNT_STAT5	RESERVED			LANE_ENA5		ECNT_TCR5			0x00	R	
0x496	ECNT_STAT6	RESERVED			LANE_ENA6		ECNT_TCR6			0x00	R	
0x497	ECNT_STAT7	RESERVED			LANE_ENA7		ECNT_TCR7			0x00	R	
0x4B0	LINK_STATUS0	BDE0	NIT0	UEK0	ILD0	ILS0	CKS0	FS0	CGS0	0x00	R	
0x4B1	LINK_STATUS1	BDE1	NIT1	UEK1	ILD1	ILS1	CKS1	FS1	CGS1	0x00	R	
0x4B2	LINK_STATUS2	BDE2	NIT2	UEK2	ILD2	ILS2	CKS2	FS2	CGS2	0x00	R	
0x4B3	LINK_STATUS3	BDE3	NIT3	UEK3	ILD3	ILS3	CKS3	FS3	CGS3	0x00	R	
0x4B4	LINK_STATUS4	BDE4	NIT4	UEK4	ILD4	ILS4	CKS4	FS4	CGS4	0x00	R	
0x4B5	LINK_STATUS5	BDE5	NIT5	UEK5	ILD5	ILS5	CKS5	FS5	CGS5	0x00	R	
0x4B6	LINK_STATUS6	BDE6	NIT6	UEK6	ILD6	ILS6	CKS6	FS6	CGS6	0x00	R	
0x4B7	LINK_STATUS7	BDE7	NIT7	UEK7	ILD7	ILS7	CKS7	FS7	CGS7	0x00	R	
0x4B8	JESD_IRQ_ENABLEA	EN_BDE	EN_NIT	EN_UEK	EN_ILD	EN_ILS	EN_CKS	EN_FS	EN_CGS	0x00	R/W	
0x4B9	JESD_IRQ_ENABLEB	RESERVED							EN_ILAS	0x00	R/W	
0x4BA	JESD_IRQ_STATUSA	IRQ_BDE	IRQ_NIT	IRQ_UEK	IRQ_ILD	IRQ_ILS	IRQ_CKS	IRQ_FS	IRQ_CGS	0x00	R/W	
0x4BB	JESD_IRQ_STATUSB	RESERVED							IRQ_ILAS	0x00	R/W	
0x4BC	IRQ_OUTPUT_MUX_JESD	RESERVED							MUX_JESD_IRQ	0x00	R/W	
0x580	BE_SOFT_OFF_GAIN_CTRL	BE_SOFT_OFF_GAIN_EN	RESERVED				BE_GAIN_RAMP_RATE				0x00	R/W
0x581	BE_SOFT_OFF_ENABLE	ENA_SHORT_PAERR_SOFTOFF	ENA_LONG_PAERR_SOFTOFF	RESERVED		ENA_JESD_ERR_SOFTOFF	ROTATE_SOFT_OFF_EN	TXEN_SOFT_OFF_EN	SPI_SOFT_OFF_EN	0xC6	R/W	
0x582	BE_SOFT_ON_ENABLE	SPI_SOFT_ON_EN	LONG_LEVEL_SOFTON_EN	RESERVED							0x40	R/W
0x583	LONG_PA_THRES_LSB	LONG_PA_THRESHOLD[7:0]									0x00	R/W
0x584	LONG_PA_THRES_MSB	RESERVED			LONG_PA_THRESHOLD[12:8]						0x00	R/W

Reg.	Name	Bit 7	Bit 6	Bit 5	Bit 4	Bit 3	Bit 2	Bit 1	Bit 0	Reset	RW
0x585	LONG_PA_CONTROL	LONG_PA_ENABLE	RESERVED			LONG_PA_AVG_TIME				0x00	R/W
0x586	LONG_PA_POWER_LSB	LONG_PA_POWER[7:0]								0x00	R
0x587	LONG_PA_POWER_MSB	RESERVED			LONG_PA_POWER[12:8]				0x00	R	
0x588	SHORT_PA_THRES_LSB	SHORT_PA_THRESHOLD[7:0]								0x00	R/W
0x589	SHORT_PA_THRES_MSB	RESERVED			SHORT_PA_THRESHOLD[12:8]				0x00	R/W	
0x58A	SHORT_PA_CONTROL	SHORT_PA_ENABLE	RESERVED				SHORT_PA_AVG_TIME			0x00	R/W
0x58B	SHORT_PA_POWER_LSB	SHORT_PA_POWER[7:0]								0x00	R
0x58C	SHORT_PA_POWER_MSB	RESERVED			SHORT_PA_POWER[12:8]				0x00	R	
0x58D	TXEN_SM_0	RESERVED							ENA_TXENSM	0x50	R/W
0x596	BLANKING_CTRL	RESERVED			SPI_TXEN	ENA_SPI_TXEN	RESERVED			0x00	R/W
0x597	JESD_PA_INT0	JESD_PA_INT_CNTRL[7:0]								0x00	R/W
0x598	JESD_PA_INT1	RESERVED							JESD_PA_INT_CNTRL[8]	0x00	R/W
0x599	TXEN_FLUSH_CTRL0	RESERVED							SPI_FLUSH_EN	0x01	R/W
0x705	NVM_LOADER_EN	RESERVED							NVM_BLR_EN	0x00	R/W
0x790	DACPLL_PDCTRL0	PLL_PD5	PLL_PD4			PLL_PD3	PLL_PD2	PLL_PD1	PLL_PD0	0x02	R/W
0x791	DACPLL_PDCTRL1	RESERVED			PLL_PD10	PLL_PD9	PLL_PD8	PLL_PD7	PLL_PD6	0x00	R/W
0x792	DACPLL_CTRL0	RESERVED						D_CAL_RESET	D_RESET_VCO_DIV	0x02	R/W
0x793	DACPLL_CTRL1	RESERVED						M_DIVIDER-1		0x18	R/W
0x794	DACPLL_CTRL2	RESERVED			DACPLL_CP				0x04	R/W	
0x795	DACPLL_CTRL3	RESERVED			D_CP_CALBITS				0x08	R/W	
0x796	DACPLL_CTRL4	PLL_CTRL0			RESERVED				0xD2	R/W	
0x797	DACPLL_CTRL5	RESERVED			PLL_CTRL1				0x20	R/W	
0x798	DACPLL_CTRL6	RESERVED	PLL_CTRL3	PLL_CTRL2				0x1C	R/W		
0x799	DACPLL_CTRL7	ADC_CLK_DIVIDER			N_DIVIDER				0x08	R/W	
0x7A0	DACPLL_CTRL9	RESERVED		D_EN_VAR_FINE_PRE	RESERVED		D_EN_VAR_COARSE_PRE	RESERVED		0x90	R/W
0x7A2	DACPLL_CTRL10	RESERVED	D_REGULATOR_CAL_WAIT		D_VCO_CAL_WAIT		D_VCO_CAL_CYCLES		RESERVED	0x35	R/W
0x7B5	PLL_STATUS	RESERVED							PLL_LOCK	0x00	R
0x800	DDSM_HOPF_CTRL	HOPF_MODE		RESERVED	HOPF_SEL				0x00	R/W	
0x806	DDSM_HOPF_FTW1_0	HOPF_FTW1[7:0]								0x00	R/W
0x807	DDSM_HOPF_FTW1_1	HOPF_FTW1[15:8]								0x00	R/W
0x808	DDSM_HOPF_FTW1_2	HOPF_FTW1[23:16]								0x00	R/W
0x809	DDSM_HOPF_FTW1_3	HOPF_FTW1[31:24]								0x00	R/W
0x80A	DDSM_HOPF_FTW2_0	HOPF_FTW2[7:0]								0x00	R/W
0x80B	DDSM_HOPF_FTW2_1	HOPF_FTW2[15:8]								0x00	R/W
0x80C	DDSM_HOPF_FTW2_2	HOPF_FTW2[23:16]								0x00	R/W
0x80D	DDSM_HOPF_FTW2_3	HOPF_FTW2[31:24]								0x00	R/W
0x80E	DDSM_HOPF_FTW3_0	HOPF_FTW3[7:0]								0x00	R/W
0x80F	DDSM_HOPF_FTW3_1	HOPF_FTW3[15:8]								0x00	R/W

Reg.	Name	Bit 7	Bit 6	Bit 5	Bit 4	Bit 3	Bit 2	Bit 1	Bit 0	Reset	RW
0x810	DDSM_ HOPF_FT3_2				HOPF_FT3[23:16]					0x00	R/W
0x811	DDSM_ HOPF_FT3_3				HOPF_FT3[31:24]					0x00	R/W
0x812	DDSM_ HOPF_FT4_0				HOPF_FT4[7:0]					0x00	R/W
0x813	DDSM_ HOPF_FT4_1				HOPF_FT4[15:8]					0x00	R/W
0x814	DDSM_ HOPF_FT4_2				HOPF_FT4[23:16]					0x00	R/W
0x815	DDSM_ HOPF_FT4_3				HOPF_FT4[31:24]					0x00	R/W
0x816	DDSM_ HOPF_FT5_0				HOPF_FT5[7:0]					0x00	R/W
0x817	DDSM_ HOPF_FT5_1				HOPF_FT5[15:8]					0x00	R/W
0x818	DDSM_ HOPF_FT5_2				HOPF_FT5[23:16]					0x00	R/W
0x819	DDSM_ HOPF_FT5_3				HOPF_FT5[31:24]					0x00	R/W
0x81A	DDSM_ HOPF_FT6_0				HOPF_FT6[7:0]					0x00	R/W
0x81B	DDSM_ HOPF_FT6_1				HOPF_FT6[15:8]					0x00	R/W
0x81C	DDSM_ HOPF_FT6_2				HOPF_FT6[23:16]					0x00	R/W
0x81D	DDSM_ HOPF_FT6_3				HOPF_FT6[31:24]					0x00	R/W
0x81E	DDSM_ HOPF_FT7_0				HOPF_FT7[7:0]					0x00	R/W
0x81F	DDSM_ HOPF_FT7_1				HOPF_FT7[15:8]					0x00	R/W
0x820	DDSM_ HOPF_FT7_2				HOPF_FT7[23:16]					0x00	R/W
0x821	DDSM_ HOPF_FT7_3				HOPF_FT7[31:24]					0x00	R/W
0x822	DDSM_ HOPF_FT8_0				HOPF_FT8[7:0]					0x00	R/W
0x823	DDSM_ HOPF_FT8_1				HOPF_FT8[15:8]					0x00	R/W
0x824	DDSM_ HOPF_FT8_2				HOPF_FT8[23:16]					0x00	R/W
0x825	DDSM_ HOPF_FT8_3				HOPF_FT8[31:24]					0x00	R/W
0x826	DDSM_ HOPF_FT9_0				HOPF_FT9[7:0]					0x00	R/W
0x827	DDSM_ HOPF_FT9_1				HOPF_FT9[15:8]					0x00	R/W
0x828	DDSM_ HOPF_FT9_2				HOPF_FT9[23:16]					0x00	R/W
0x829	DDSM_ HOPF_FT9_3				HOPF_FT9[31:24]					0x00	R/W
0x82A	DDSM_ HOPF_FT10_0				HOPF_FT10[7:0]					0x00	R/W
0x82B	DDSM_ HOPF_FT10_1				HOPF_FT10[15:8]					0x00	R/W
0x82C	DDSM_ HOPF_FT10_2				HOPF_FT10[23:16]					0x00	R/W
0x82D	DDSM_ HOPF_FT10_3				HOPF_FT10[31:24]					0x00	R/W
0x82E	DDSM_ HOPF_FT11_0				HOPF_FT11[7:0]					0x00	R/W
0x82F	DDSM_ HOPF_FT11_1				HOPF_FT11[15:8]					0x00	R/W
0x830	DDSM_ HOPF_FT11_2				HOPF_FT11[23:16]					0x00	R/W
0x831	DDSM_ HOPF_FT11_3				HOPF_FT11[31:24]					0x00	R/W
0x832	DDSM_ HOPF_FT12_0				HOPF_FT12[7:0]					0x00	R/W

Reg.	Name	Bit 7	Bit 6	Bit 5	Bit 4	Bit 3	Bit 2	Bit 1	Bit 0	Reset	RW
0x833	DDSM_ HOPF_FTW12_1				HOPF_FTW12[15:8]					0x00	R/W
0x834	DDSM_ HOPF_FTW12_2				HOPF_FTW12[23:16]					0x00	R/W
0x835	DDSM_ HOPF_FTW12_3				HOPF_FTW12[31:24]					0x00	R/W
0x836	DDSM_ HOPF_FTW13_0				HOPF_FTW13[7:0]					0x00	R/W
0x837	DDSM_ HOPF_FTW13_1				HOPF_FTW13[15:8]					0x00	R/W
0x838	DDSM_ HOPF_FTW13_2				HOPF_FTW13[23:16]					0x00	R/W
0x839	DDSM_ HOPF_FTW13_3				HOPF_FTW13[31:24]					0x00	R/W
0x83A	DDSM_ HOPF_FTW14_0				HOPF_FTW14[7:0]					0x00	R/W
0x83B	DDSM_ HOPF_FTW14_1				HOPF_FTW14[15:8]					0x00	R/W
0x83C	DDSM_ HOPF_FTW14_2				HOPF_FTW14[23:16]					0x00	R/W
0x83D	DDSM_ HOPF_FTW14_3				HOPF_FTW14[31:24]					0x00	R/W
0x83E	DDSM_ HOPF_FTW15_0				HOPF_FTW15[7:0]					0x00	R/W
0x83F	DDSM_ HOPF_FTW15_1				HOPF_FTW15[15:8]					0x00	R/W
0x840	DDSM_ HOPF_FTW15_2				HOPF_FTW15[23:16]					0x00	R/W
0x841	DDSM_ HOPF_FTW15_3				HOPF_FTW15[31:24]					0x00	R/W
0x842	DDSM_ HOPF_FTW16_0				HOPF_FTW16[7:0]					0x00	R/W
0x843	DDSM_ HOPF_FTW16_1				HOPF_FTW16[15:8]					0x00	R/W
0x844	DDSM_ HOPF_FTW16_2				HOPF_FTW16[23:16]					0x00	R/W
0x845	DDSM_ HOPF_FTW16_3				HOPF_FTW16[31:24]					0x00	R/W
0x846	DDSM_ HOPF_FTW17_0				HOPF_FTW17[7:0]					0x00	R/W
0x847	DDSM_ HOPF_FTW17_1				HOPF_FTW17[15:8]					0x00	R/W
0x848	DDSM_ HOPF_FTW17_2				HOPF_FTW17[23:16]					0x00	R/W
0x849	DDSM_ HOPF_FTW17_3				HOPF_FTW17[31:24]					0x00	R/W
0x84A	DDSM_ HOPF_FTW18_0				HOPF_FTW18[7:0]					0x00	R/W
0x84B	DDSM_ HOPF_FTW18_1				HOPF_FTW18[15:8]					0x00	R/W
0x84C	DDSM_ HOPF_FTW18_2				HOPF_FTW18[23:16]					0x00	R/W
0x84D	DDSM_ HOPF_FTW18_3				HOPF_FTW18[31:24]					0x00	R/W
0x84E	DDSM_ HOPF_FTW19_0				HOPF_FTW19[7:0]					0x00	R/W
0x84F	DDSM_ HOPF_FTW19_1				HOPF_FTW19[15:8]					0x00	R/W
0x850	DDSM_ HOPF_FTW19_2				HOPF_FTW19[23:16]					0x00	R/W
0x851	DDSM_ HOPF_FTW19_3				HOPF_FTW19[31:24]					0x00	R/W
0x852	DDSM_ HOPF_FTW20_0				HOPF_FTW20[7:0]					0x00	R/W
0x853	DDSM_ HOPF_FTW20_1				HOPF_FTW20[15:8]					0x00	R/W
0x854	DDSM_ HOPF_FTW20_2				HOPF_FTW20[23:16]					0x00	R/W
0x855	DDSM_ HOPF_FTW20_3				HOPF_FTW20[31:24]					0x00	R/W

Reg.	Name	Bit 7	Bit 6	Bit 5	Bit 4	Bit 3	Bit 2	Bit 1	Bit 0	Reset	RW	
0x856	DDSM_ HOPF_FT21_0				HOPF_FT21[7:0]						0x00	R/W
0x857	DDSM_ HOPF_FT21_1				HOPF_FT21[15:8]						0x00	R/W
0x858	DDSM_ HOPF_FT21_2				HOPF_FT21[23:16]						0x00	R/W
0x859	DDSM_ HOPF_FT21_3				HOPF_FT21[31:24]						0x00	R/W
0x85A	DDSM_ HOPF_FT22_0				HOPF_FT22[7:0]						0x00	R/W
0x85B	DDSM_ HOPF_FT22_1				HOPF_FT22[15:8]						0x00	R/W
0x85C	DDSM_ HOPF_FT22_2				HOPF_FT22[23:16]						0x00	R/W
0x85D	DDSM_ HOPF_FT22_3				HOPF_FT22[31:24]						0x00	R/W
0x85E	DDSM_ HOPF_FT23_0				HOPF_FT23[7:0]						0x00	R/W
0x85F	DDSM_ HOPF_FT23_1				HOPF_FT23[15:8]						0x00	R/W
0x860	DDSM_ HOPF_FT23_2				HOPF_FT23[23:16]						0x00	R/W
0x861	DDSM_ HOPF_FT23_3				HOPF_FT23[31:24]						0x00	R/W
0x862	DDSM_ HOPF_FT24_0				HOPF_FT24[7:0]						0x00	R/W
0x863	DDSM_ HOPF_FT24_1				HOPF_FT24[15:8]						0x00	R/W
0x864	DDSM_ HOPF_FT24_2				HOPF_FT24[23:16]						0x00	R/W
0x865	DDSM_ HOPF_FT24_3				HOPF_FT24[31:24]						0x00	R/W
0x866	DDSM_ HOPF_FT25_0				HOPF_FT25[7:0]						0x00	R/W
0x867	DDSM_ HOPF_FT25_1				HOPF_FT25[15:8]						0x00	R/W
0x868	DDSM_ HOPF_FT25_2				HOPF_FT25[23:16]						0x00	R/W
0x869	DDSM_ HOPF_FT25_3				HOPF_FT25[31:24]						0x00	R/W
0x86A	DDSM_ HOPF_FT26_0				HOPF_FT26[7:0]						0x00	R/W
0x86B	DDSM_ HOPF_FT26_1				HOPF_FT26[15:8]						0x00	R/W
0x86C	DDSM_ HOPF_FT26_2				HOPF_FT26[23:16]						0x00	R/W
0x86D	DDSM_ HOPF_FT26_3				HOPF_FT26[31:24]						0x00	R/W
0x86E	DDSM_ HOPF_FT27_0				HOPF_FT27[7:0]						0x00	R/W
0x86F	DDSM_ HOPF_FT27_1				HOPF_FT27[15:8]						0x00	R/W
0x870	DDSM_ HOPF_FT27_2				HOPF_FT27[23:16]						0x00	R/W
0x871	DDSM_ HOPF_FT27_3				HOPF_FT27[31:24]						0x00	R/W
0x872	DDSM_ HOPF_FT28_0				HOPF_FT28[7:0]						0x00	R/W
0x873	DDSM_ HOPF_FT28_1				HOPF_FT28[15:8]						0x00	R/W
0x874	DDSM_ HOPF_FT28_2				HOPF_FT28[23:16]						0x00	R/W
0x875	DDSM_ HOPF_FT28_3				HOPF_FT28[31:24]						0x00	R/W
0x876	DDSM_ HOPF_FT29_0				HOPF_FT29[7:0]						0x00	R/W
0x877	DDSM_ HOPF_FT29_1				HOPF_FT29[15:8]						0x00	R/W
0x878	DDSM_ HOPF_FT29_2				HOPF_FT29[23:16]						0x00	R/W

Reg.	Name	Bit 7	Bit 6	Bit 5	Bit 4	Bit 3	Bit 2	Bit 1	Bit 0	Reset	RW
0x879	DDSM_ HOPF_FT29_3				HOPF_FT29[31:24]					0x00	R/W
0x87A	DDSM_ HOPF_FT30_0				HOPF_FT30[7:0]					0x00	R/W
0x87B	DDSM_ HOPF_FT30_1				HOPF_FT30[15:8]					0x00	R/W
0x87C	DDSM_ HOPF_FT30_2				HOPF_FT30[23:16]					0x00	R/W
0x87D	DDSM_ HOPF_FT30_3				HOPF_FT30[31:24]					0x00	R/W
0x87E	DDSM_ HOPF_FT31_0				HOPF_FT31[7:0]					0x00	R/W
0x87F	DDSM_ HOPF_FT31_1				HOPF_FT31[15:8]					0x00	R/W
0x880	DDSM_ HOPF_FT31_2				HOPF_FT31[23:16]					0x00	R/W
0x881	DDSM_ HOPF_FT31_3				HOPF_FT31[31:24]					0x00	R/W

## REGISTER DETAILS

Table 62. Register Details

Addr.	Name	Bits	Bit Name	Settings	Description	Reset	Access
0x000	SPI_INTFCONFA	7	SOFTRESET_M		Soft reset (mirror). Set this bit to mirror Bit 0.	0x0	R
		6	LSBFIRST_M		LSB first (mirror). Set this bit to mirror Bit 1.	0x0	R
		5	ADDRINC_M		Address increment (mirror). Set this bit to mirror Bit 2.	0x0	R
		4	SDOACTIVE_M		SDO active (mirror). Set this bit to mirror Bit 3.	0x0	R
		3	SDOACTIVE		SDO active. Enables 4-wire SPI bus mode.	0x0	R/W
		2	ADDRINC		Address increment. When set, this bit causes incrementing streaming addresses; otherwise, descending addresses are generated.	0x0	R/W
				1 0	Streaming addresses are incremented. Streaming addresses are decremented.		
		1	LSBFIRST		LSB first. When set, this bit causes SPI input and output data to be oriented as LSB first. If this bit is clear, data is oriented as MSB first. Shift LSB in first. Shift MSB in first.	0x0	R/W
		1 0					
0x001	SPI_INTFCONFB	7	SINGLEINS		Single instruction. Perform single transfers. Perform multiple transfers.	0x0	R/W
		6	CSSTALL		$\overline{CS}$ stalling. Disable $\overline{CS}$ stalling. Enable $\overline{CS}$ stalling.	0x0	R/W
		[5:0]	RESERVED		Reserved.	0x0	R/W
0x003	SPI_CHIPTYPE	[7:0]	CHIP_TYPE		Chip type.	0x4	R
0x004	SPI_PRODIDL	[7:0]	PROD_ID[7:0]		Product ID. Updated once the bootloader completes	0x72	R
0x005	SPI_PRODIDH	[7:0]	PROD_ID[15:8]		Product ID. Updated once the bootloader completes	0x91	R
0x006	SPI_CHIPGRADE	[7:4]	PROD_GRADE		Product grade.	0x0	R
		[3:0]	DEV_REVISION		Device revision.	0x4	R
0x008	SPI_PAGEINDX	[7:6]	MAINDAC_PAGE		Sets the main DAC paging. Each high bit in this field pages a DAC starting at the LSB. Both main DACs can be paged and programmed at the same time if desired.	0x3	R/W
		[5:0]	CHANNEL_PAGE		Sets channel paging. Each high bit in this field pages a complex channel starting at the LSB. Multiple channels can be paged and programmed at a time if desired.	0x3F	R/W
0x00A	SPI_SCRATCHPAD	[7:0]	SCRATCHPAD		Scratch pad read/write register.	0x0	R/W
0x010	CHIP_ID_L	[7:0]	CHIP_ID[7:0]		Chip ID serial number.	0x0	R
0x011	CHIP_ID_M1	[7:0]	CHIP_ID[15:8]		Chip ID serial number.	0x0	R
0x012	CHIP_ID_M2	[7:0]	CHIP_ID[23:16]		Chip ID serial number.	0x0	R
0x013	CHIP_ID_H	[7:0]	CHIP_ID[31:24]		Chip ID serial number.	0x0	R

Addr.	Name	Bits	Bit Name	Settings	Description	Reset	Access
0x020	IRQ_ENABLE	[7:5]	RESERVED		Reserved.	0x0	R
		4	EN_SYSREF_JITTER		Enable SYSREF± jitter interrupt.	0x0	R/W
		3	EN_DATA_READY		Enable JESD204B receiver ready (JRX_DATA_READY) low interrupt.	0x0	R/W
		2	EN_LANE_FIFO		Enable lane FIFO overflow/underflow interrupt.	0x0	R/W
		1	EN_PRBSQ		Enable PRBS imaginary error interrupt.	0x0	R/W
		0	EN_PRBSI		Enable PRBS real error interrupt.	0x0	R/W
0x021	IRQ_ENABLE0	[7:4]	RESERVED		Reserved.	0x0	R
		3	EN_DAC0_CAL_DONE		Enable DAC0 calibration complete interrupt.	0x0	R/W
		[2:1]	RESERVED		Reserved.	0x0	R/W
		0	EN_PAERR0		Enable PA protection error interrupt for DAC0.	0x0	R/W
0x022	IRQ_ENABLE1	[7:4]	RESERVED		Reserved.	0x0	R
		3	EN_DAC1_CAL_DONE		Enable DAC1 calibration complete interrupt.	0x0	R/W
		[2:1]	RESERVED		Reserved.	0x0	R/W
		0	EN_PAERR1		Enable PA protection error interrupt for DAC1.	0x0	R/W
0x023	IRQ_ENABLE2	[7:6]	RESERVED		Reserved.	0x0	R
		5	EN_DLL_LOST		Enable DLL lock lost interrupt.	0x0	R/W
		4	EN_DLL_LOCK		Enable DLL lock interrupt.	0x0	R/W
		[3:2]	RESERVED		Reserved.	0x0	R/W
		1	EN_PLL_LOST		Enable PLL lock lost interrupt.	0x0	R/W
		0	EN_PLL_LOCK		Enable PLL lock interrupt.	0x0	R/W
0x024	IRQ_STATUS	[7:5]	RESERVED		Reserved.	0x0	R
		4	IRQ_SYSREF_JITTER		SYSREF± jitter too large. If EN_SYSREF_JITTER is low, IRQ_SYSREF_JITTER shows the current status. If EN_SYSREF_JITTER is high, IRQ_SYSREF_JITTER latches and pulls the IRQx pin low (x = the MUX_SYSREF_JITTER setting). Writing a 1 to IRQ_SYSREF_JITTER when latched clears the bit.	0x0	R/W
		3	IRQ_DATA_READY		JESD204x receiver data ready is low. If EN_DATA_READY is low, IRQ_DATA_READY shows the current status. If EN_DATA_READY is high, IRQ_DATA_READY latches and pulls the IRQx pin low (x = MUX_DATA_READY setting). Writing a 1 to IRQ_DATA_READY when latched clears the bit.	0x0	R/W
		2	IRQ_LANE_FIFO		Lane FIFO overflow/underflow. If EN_LANE_FIFO is low, IRQ_LANE_FIFO shows the current status. If EN_LANE_FIFO is high, IRQ_LANE_FIFO latches and pulls the IRQx pin low (x = MUX_LANE_FIFO setting). Writing a 1 to IRQ_LANE_FIFO when latched clears the bit.	0x0	R/W
		1	IRQ_PRBSQ		DAC1 PRBS error. If EN_PRBSQ is low, IRQ_PRBSQ shows the current status. If EN_PRBSQ is high, IRQ_PRBSQ latches and pulls the IRQx pin low (x = MUX_PRBSQ setting). Writing a 1 to IRQ_PRBSQ when latched clears the bit.	0x0	R/W

Addr.	Name	Bits	Bit Name	Settings	Description	Reset	Access
		0	IRQ_PRBSI		DAC0 PRBS error. If EN_PRBSI is low, IRQ_PRBSI shows the current status. If EN_PRBSI is high, IRQ_PRBSI latches and pulls the IRQx pin low (x = MUX_PRBSI setting). Writing a 1 to IRQ_PRBSI when latched clears the bit.	0x0	R/W
0x025	IRQ_STATUS0	[7:4]	RESERVED		Reserved.	0x0	R
		3	IRQ_DAC0_CAL_DONE		DAC0 calibration done. If EN_DAC0_CAL_DONE is low, IRQ_DAC0_CAL_DONE shows the current status. If EN_DAC0_CAL_DONE is high, IRQ_DAC0_CAL_DONE latches and pulls the IRQx pin low (x = MUX_DAC0_CAL_DONE setting). Writing a 1 to IRQ_DAC0_CAL_DONE when latched clears the bit.	0x0	R/W
		[2:1]	RESERVED		Reserved.	0x0	R/W
		0	IRQ_PAERRO		DAC0 PA error. If EN_PAERRO is low, IRQ_PAERRO shows the current status. If EN_PAERRO is high, IRQ_PAERRO latches and pulls the IRQx pin low (x = MUX_PAERRO setting). Writing a 1 to IRQ_PAERRO when latched clears the bit.	0x0	R/W
0x026	IRQ_STATUS1	[7:4]	RESERVED		Reserved.	0x0	R
		3	IRQ_DAC1_CAL_DONE		DAC1 calibration done. If EN_DAC0_CAL_DONE is low, IRQ_DAC1_CAL_DONE shows the current status. If EN_DAC1_CAL_DONE is high, IRQ_DAC1_CAL_DONE latches and pulls the IRQx pin low (x = MUX_DAC1_CAL_DONE setting). Writing a 1 to IRQ_DAC1_CAL_DONE when latched clears the bit.	0x0	R/W
		[2:1]	RESERVED		Reserved.	0x0	R/W
		0	IRQ_PAERR1		DAC1 PA error. If EN_PAERR1 is low, IRQ_PAERR1 shows the current status. If EN_PAERR1 is high, IRQ_PAERR1 latches and pulls the IRQx pin low (x = MUX_PAERR1 setting). Writing a 1 to IRQ_PAERR1 when latched clears the bit.	0x0	R/W
0x027	IRQ_STATUS2	[7:6]	RESERVED		Reserved.	0x0	R
		5	IRQ_DLL_LOST		DLL lost. If EN_DLL_LOST is low, IRQ_DLL_LOST shows the current status. If EN_DLL_LOST is high, IRQ_DLL_LOST latches and pulls the IRQx pin low (x = MUX_DLL_LOST setting). Writing a 1 to IRQ_DLL_LOST when latched clears the bit.	0x0	R/W
		4	IRQ_DLL_LOCK		DLL locked. If EN_DLL_LOCK is low, IRQ_DLL_LOCK shows current status. If EN_DLL_LOCK is high, IRQ_DLL_LOCK latches and pulls the IRQx pin low (x = MUX_DLL_LOCK setting). Writing a 1 to IRQ_DLL_LOCK when latched clears the bit.	0x0	R/W
		[3:2]	RESERVED		Reserved.	0x0	R/W
		1	IRQ_PLL_LOST		DAC PLL lock lost. If EN_PLL_LOST is low, IRQ_PLL_LOST shows the current status. If EN_PLL_LOST is high, IRQ_PLL_LOST latches and pulls the IRQx pin low (x = MUX_PLL_LOST setting). Writing a 1 to IRQ_PLL_LOST when latched clears the bit.	0x0	R/W

Addr.	Name	Bits	Bit Name	Settings	Description	Reset	Access
		0	IRQ_PLL_LOCK		DAC PLL locked. If EN_PLL_LOCK is low, IRQ_PLL_LOCK shows the current status. If EN_PLL_LOCK is high, IRQ_PLL_LOCK latches and pulls the IRQx pin low (x = MUX_PLL_LOCK setting). Writing a 1 to IRQ_PLL_LOCK when latched clears the bit.	0x0	R/W
0x028	IRQ_OUTPUT_MUX	[7:5]	RESERVED		Reserved.	0x0	R
		4	MUX_SYSREF_JITTER	0 1	If EN_SYSREF_JITTER is set, this control chooses the IRQx output pin on which the event is triggered. Route IRQ trigger signal to the $\overline{\text{IRQ0}}$ pin. Route IRQ trigger signal to the $\overline{\text{IRQ1}}$ pin.	0x0	R/W
		3	MUX_DATA_READY	0 1	If EN_DATA_READY is set, this control chooses the IRQx output pin on which the event is triggered. Route IRQ trigger signal to the $\overline{\text{IRQ0}}$ pin. Route IRQ trigger signal to the $\overline{\text{IRQ1}}$ pin.	0x0	R/W
		2	MUX_LANE_FIFO	0 1	If EN_LANE_FIFO is set, this control chooses the IRQx output pin on which the event is triggered. Route IRQ trigger signal to the $\overline{\text{IRQ0}}$ pin. Route IRQ trigger signal to the $\overline{\text{IRQ1}}$ pin.	0x0	R/W
		1	MUX_PRBSQ	0 1	If EN_PRBSQ is set, this control chooses the IRQx output pin on which the event is triggered. Route IRQ trigger signal to the $\overline{\text{IRQ0}}$ pin. Route IRQ trigger signal to the $\overline{\text{IRQ1}}$ pin.	0x0	R/W
		0	MUX_PRBSI	0 1	If EN_PRBSI is set, this control chooses the IRQx output pin on which the event is triggered. Route IRQ trigger signal to the $\overline{\text{IRQ0}}$ pin. Route IRQ trigger signal to the $\overline{\text{IRQ1}}$ pin.	0x0	R/W
0x029	IRQ_OUTPUT_MUX0	[7:4]	RESERVED		Reserved.	0x0	R
		3	MUX_DAC0_CAL_DONE	0 1	If EN_DAC0_CAL_DONE is set, this control chooses the IRQx output pin on which the event is triggered. Route IRQ trigger signal to the $\overline{\text{IRQ0}}$ pin. Route IRQ trigger signal to the $\overline{\text{IRQ1}}$ pin.	0x0	R/W
		[2:1]	RESERVED		Reserved.	0x0	R/W
		0	MUX_PAERRO	0 1	If EN_PAERRO is set, this control chooses the IRQx output pin on which the event is triggered. Route IRQ trigger signal to the $\overline{\text{IRQ0}}$ pin. Route IRQ trigger signal to the $\overline{\text{IRQ1}}$ pin.	0x0	R/W
0x02A	IRQ_OUTPUT_MUX1	[7:4]	RESERVED		Reserved.	0x0	R
		3	MUX_DAC1_CAL_DONE	0 1	If EN_DAC1_CAL_DONE is set, this control chooses the IRQx output pin on which the event is triggered. Route IRQ trigger signal to the $\overline{\text{IRQ0}}$ pin. Route IRQ trigger signal to the $\overline{\text{IRQ1}}$ pin.	0x0	R/W
		[2:1]	RESERVED		Reserved.	0x0	R/W

Addr.	Name	Bits	Bit Name	Settings	Description	Reset	Access
		0	MUX_PAERR1	0 1	If EN_PAERR1 is set, this control chooses the $\overline{\text{IRQx}}$ output pin on which the event is triggered. Route IRQ trigger signal to the $\overline{\text{IRQ0}}$ pin. Route IRQ trigger signal to the $\overline{\text{IRQ1}}$ pin.	0x0	R/W
0x02B	IRQ_OUTPUT_MUX2	[7:6]	RESERVED		Reserved.	0x0	R
		5	MUX_DLL_LOST	0 1	If EN_DLL_LOST is set, this control chooses the $\overline{\text{IRQx}}$ output pin on which the event is triggered. Route IRQ trigger signal to the $\overline{\text{IRQ0}}$ pin. Route IRQ trigger signal to the $\overline{\text{IRQ1}}$ pin.	0x0	R/W
		4	MUX_DLL_LOCK	0 1	If EN_DLL_LOCK is set, this control chooses the $\overline{\text{IRQx}}$ output pin on which the event is triggered. Route IRQ trigger signal to the $\overline{\text{IRQ0}}$ pin. Route IRQ trigger signal to the $\overline{\text{IRQ1}}$ pin.	0x0	R/W
		[3:2]	RESERVED		Reserved.	0x0	R/W
		1	MUX_PLL_LOST	0 1	If EN_PLL_LOST is set, this control chooses the $\overline{\text{IRQx}}$ pin on which the event is triggered. Route IRQ trigger signal to the $\overline{\text{IRQ0}}$ pin. Route IRQ trigger signal to the $\overline{\text{IRQ1}}$ pin.	0x0	R/W
		0	MUX_PLL_LOCK	0 1	If EN_PLL_LOCK is set, this control chooses the $\overline{\text{IRQx}}$ pin on which the event is triggered. Route IRQ trigger signal to the $\overline{\text{IRQ0}}$ pin. Route IRQ trigger signal to the $\overline{\text{IRQ1}}$ pin.	0x0	R/W
0x02C	IRQ_STATUS_ALL	[7:1]	RESERVED		Reserved.	0x0	R
		0	IRQ_STATUS_ALL		This bit is an OR of all the bits in Register 0x24 to Register 0x27. Writing a one to this bit clears any latched $\overline{\text{IRQx}}$ signals in Register 0x24 to Register 0x27.	0x0	R/W
0x036	SYSREF_COUNT	[7:0]	SYSREF_COUNT		Number of rising SYSREF $\pm$ edges to ignore before synchronization (pulse counting mode).	0x0	R/W
0x039	SYSREF_ERR_WINDOW	7	RESERVED		Reserved.	0x0	R
		[6:0]	SYSREF_ERR_WINDOW		Amount of jitter allowed on the SYSREF $\pm$ input. SYSREF $\pm$ jitter variations larger than this trigger an interrupt. Units are in DAC clocks.	0x0	R/W
0x03A	SYSREF_MODE	[7:5]	RESERVED		Reserved.	0x0	R
		4	SYNC_ROTATION_DONE		Synchronization logic rotation complete flag.	0x1	R
		[3:2]	RESERVED		Reserved.	0x0	R
		1	SYSREF_MODE_ONESHOT	00 01	Enable one-shot synchronization rotation mode. Monitor mode. Status/error flag for $\overline{\text{IRQ\_SYSREF\_JITTER}}$ is 1 if the SYSREF $\pm$ edge is outside the error window (Register 0x039, Bits[6:0]). Perform a single synchronization on the next SYSREF $\pm$ , then switch to monitor mode.	0x0	R/W
		0	RESERVED		Reserved.	0x0	R/W

Addr.	Name	Bits	Bit Name	Settings	Description	Reset	Access
0x03B	ROTATION_MODE	7	SYNCLOGIC_EN		This bit must always be set to 1 (default) for both Subclass 0 and Subclass 1 operations.	0x1	R/W
		6	RESERVED		Reserved. For proper operation, write this bit to a 1.	0x0	R/W
		5	PERIODIC_RST_EN		Synchronization required setting. Always set this bit to 1 for both Subclass 0 and Subclass 1 operation.	0x1	R/W
		4	NCORST_AFTER_ROT_EN		Set this bit to 1 to reset all NCOs after digital reset or synchronization rotation. Either this control or the START_NCO_SYNC bit (Register 0x1E7, Bit 0) can be used to reset all the NCOs (main and channel datapaths).	0x1	R/W
		[3:2]	RESERVED		Reserved.	0x0	R
		[1:0]	ROTATION_MODE		<p>Selects the circuitry to be reset when a synchronization rotation occurs. Certain bits being set to 1 determine the actions taken when a synchronization rotation is performed. Bit 0 corresponds to a SERDES clock reset and realignment. Bit 1 corresponds to a datapath soft off/on gain, which must only be used if PA protection is in use. If PA protection is not used, set Bit 1 to 0.</p> <p>0 No action, with either the SERDES clocks or the datapath, occurs when a synchronization rotation occurs.</p> <p>1 The links drop and the SERDES clocks are reset. It is recommended to set this bit high so that when a synchronization rotation is performed, the SERDES clocks realign properly.</p> <p>10 The datapath automatically uses the soft on/off functionality to turn on and off the datapath stream during a synchronization rotation to avoid corrupted data from being transmitted. Only use this feature if the PA protection block is in use.</p> <p>11 Both the SERDES clock reset and datapath soft on/off feature are enabled.</p>	0x0	R/W
0x03F	TX_ENABLE	[7:6]	RESERVED		Reserved.	0x0	R/W
		5	TXEN_DATAPATH_DAC1	<p>0 1</p>	<p>Selects whether the datapath of DAC1 is muted when the TXEN1 pin is brought low. Datapath output is normal.</p> <p>If TXEN1 = 0, the datapath output is immediately zeroed. If TXEN1 = 1, the datapath outputs normal operation.</p>	0x0	R/W
		4	TXEN_DATAPATH_DAC0	<p>0 1</p>	<p>Selects whether the datapath of DAC0 is muted when the TXEN0 pin is brought low. Datapath output is normal.</p> <p>If TXEN0 = 0, the datapath output is immediately zeroed. If TXEN0 = 1, the datapath outputs normal operation.</p>	0x0	R/W
		[3:0]	RESERVED		Reserved.	0x0	R/W
0x050	CAL_CLK_DIV	[7:4]	RESERVED		Reserved	0x2	R/W
		[3:0]	CAL_CLK_DIV		Calibration register control. Set these bits to 0xA for optimized calibration setting.	0x8	R/W

Addr.	Name	Bits	Bit Name	Settings	Description	Reset	Access
0x051	CAL_CTRL	7	CAL_CTRL0	0 1	Calibration setting. Set this bit to 1. Reset the calibration engine. Enable the calibration routine.	0x1	R/W
		[6:3]	RESERVED		Reserved.	0x0	R/W
		[2:1]	CAL_CTRL1	1	Calibration mode selection. Set this bit field to 1 for optimized calibration mode. Paged by the MAINDAC_PAGE bits in Register 0x008. Set calibration control setting.	0x1	R/W
		0	CAL_START		Start calibration. After starting calibration, do not write to any register from Register 0x051 to Register 0x061 until Register 0x052, Bit 2 reads low (indicating that the calibration is no longer active). Paged by the MAINDAC_PAGE bits in Register 0x008.	0x0	R/W
0x052	CAL_STAT	[7:3]	RESERVED		Reserved.	0x0	R/W
		2	CAL_ACTIVE		Calibration active status flag. A readback of 1 indicates the calibration routine is still in progress. This control is paged by the MAINDAC_PAGE bits in Register 0x008.	0x0	R
		1	CAL_FAIL_SEARCH		Calibration failure flag. A readback of 1 indicates the calibration routine failed and is possibly not valid. This control is paged by the MAINDAC_PAGE bits in Register 0x008.	0x0	R
		0	CAL_FINISH		Calibration complete flag. A readback of 1 indicates the calibration completed. This control is paged by the MAINDAC_PAGE bits in Register 0x008.	0x0	R
0x05A	FSC1	[7:0]	FSC_CTRL[7:0]		Sets the full-scale (maximum) current that is available from the DACx analog outputs. This control is paged by the MAINDAC_PAGE bits in Register 0x008. Full-scale current = 15.625 mA + FSC_CTRL × (25/256) (mA).	0x28	R/W
0x061	CAL_DEBUG0	7	RESERVED		Reserved.	0x0	R/W
		6	CAL_CTRL2		Calibration control. Set this bit to 1 for optimized calibration setting.	0x1	R/W
		5	CAL_CTRL3		Calibration control. Set this bit to 1 for optimized calibration setting.	0x1	R/W
		4	RESERVED		Reserved.	0x0	R/W
		3	CAL_CTRL4		Calibration control. Set this bit to 1 for optimized calibration setting.	0x0	R/W
		[2:0]	RESERVED		Reserved.	0x0	R/W
0x081	CLK_CTRL	[7:2]	RESERVED		Reserved.	0x0	R/W
		1	CAL_CLK_PD1		After the calibration is complete for DAC1 (Register 0x052, Bit 0 = 1), set this bit high to power down the calibration clock.	0x0	R/W
		0	CAL_CLK_PD0		After the calibration is complete for DAC0 (Register 0x052, Bit 0 = 1), set this bit high to power down the calibration clock.	0x0	R/W
0x083	NVM_CTRL0	7	NVM_CTRL0A		NVM register control for the ring oscillator.	0x0	R/W
		[6:2]	RESERVED		Reserved.	0x0	R
		[1:0]	NVM_CTRL0B	00 01 10 11	NVM register control for the ring oscillator. Divide by 8. Divide by 16. Divide by 32. Divide by 64.	0x2	R/W

Addr.	Name	Bits	Bit Name	Settings	Description	Reset	Access
0x084	SYSREF_CTRL	7	RESERVED		Reserved.	0x0	R/W
		6	SYSREF_INPUTMODE	0 1	Sets the input mode type for the SYSREF± pins. AC couple SYSREF±. DC couple SYSREF±.	0x0	R/W
		[5:1]	RESERVED		Reserved.	0x0	R/W
		0	SYSREF_PD	0 1	Power down the SYSREF± receiver and synchronization circuitry. If using Subclass 0, set this bit to 1 because the SYSREF± pins are not used. SYSREF± receiver is powered on. SYSREF± receiver is powered down.	0x0	R/W
0x085	NVM_CTRL1	7	RESERVED		Reserved.	0x0	R
		[6:4]	NVM_CTRL1A		NVM control. Set this control to 1 at the start of the configuration sequence (as shown in the Start-Up Sequence section) and set to 0 at the end of the start-up routine when no longer programming the device.	0x1	R/W
		[3:2]	RESERVED		Reserved.	0x0	R
		1	NVM_CTRL1B		NVM control. Set this control to 1 at the start of the configuration sequence (as shown in the Start-Up Sequence section) and set to 0 at the end of the start-up routine when no longer programming the device.	0x1	R/W
		0	NVM_CTRL1C		NVM control. Set this control to 0 at the start of the configuration sequence (as shown in the Start-Up Sequence section) and set to 1 at the end of the start-up routine when no longer programming the device.	0x1	R/W
0x08D	ADC_CLK_CTRL0	[7:5]	RESERVED		Reserved.	0x0	R
		[4:0]	CLKOUT_SWING		Controls the swing level of the ADC clock driver. Swing can be negative (inverts clock). The calculation for Code 0 to Code 9 is as follows: ADC driver swing = 993 mV – CLKOUT_SWING × 77 mV. The calculation for Code 10 to Code 19 is as follows: ADC driver swing = (20 – CLKOUT_SWING × 77 mV) – 1 V.	0x0	R/W
0x08F	ADC_CLK_CTRL2	[7:1]	RESERVED		Reserved.	0x0	R
		0	PD_CLKOUT_DRIVER		Powers down the CLKOUT± output driver.	0x0	R/W
0x090	DAC_POWERDOWN	[7:2]	RESERVED		Reserved.	0x0	R
		1	DAC_PD1	0 1	Powers down DAC1. Power up DAC1. Power down DAC1.	0x1	R/W
		0	DAC_PD0	0 1	Powers down DAC0. Power up DAC0. Power down DAC0.	0x1	R/W
0x091	ACLK_CTRL	[7:1]	RESERVED		Reserved.	0x0	R/W
		0	ACLK_POWERDOWN		Analog clock receiver power-down.	0x1	R/W

Addr.	Name	Bits	Bit Name	Settings	Description	Reset	Access
0x094	PLL_CLK_DIV	[7:2]	RESERVED		Reserved.	0x0	R
		1	PLL_VCO_DIV3_EN		Enable PLL output clock divide by 3.	0x0	R/W
		0	PLL_VCO_DIV2_EN	0 1	Enable PLL output clock divide by 2. DAC clock = PLL VCO clock frequency. DAC clock = PLL VCO clock frequency ÷ 2.	0x0	R/W
0x095	PLL_BYPASS	[7:1]	RESERVED		Reserved.	0x0	R
		0	PLL_BYPASS	0 1	Enable direct clocking (bypassing the PLL clock). Use the internal PLL to generate the DAC clock. Bypass the PLL and directly clock with the DAC clock frequency.	0x0	R/W
0x09A	NVM_CTRL	7	PD_BGR		Bias power-down. Set this bit to 1 to power down the internal bias.	0x0	R/W
		[6:0]	RESERVED		Reserved.	0x0	R/W
0x0C0	DELAY_LINE_PD	[7:6]	RESERVED		Reserved.	0x0	R
		5	DLL_CTRL0B		DLL control. Set this bit to 0 to power up the delay line during the device configuration sequence.	0x1	R/W
		4	DLL_CTRL0A		DLL control. Set this bit to 0 to power up the delay line during the device configuration sequence.	0x1	R/W
		[3:1]	RESERVED		Reserved.	0x0	R
		0	DLL_PD	0 1	Power down delay line. Set this bit to 0 to power up the delay line during the device configuration sequence. Power up and enable the delay line. Power down and bypass the delay line.	0x1	R/W
0x0C1	DLL_CTRL0	[7:6]	DLL_CTRL1C		DAC control setting. Set this control to 1 for optimal performance.	0x1	R/W
		5	DLL_CTRL1B		DLL control search mode. If the DAC frequency is <4.5 GHz, set this bit to 0; otherwise, set this bit to 1.	0x1	R/W
		[4:3]	DLL_CTRL1A		DLL control search direction. Set this control to 1 for optimal performance.	0x2	R/W
		[2:1]	RESERVED		Reserved.	0x0	R
		0	DLL_ENABLE	0 1	DLL controller enable. Disable DLL. Enable DLL.	0x0	R/W
0x0C3	DLL_STATUS	[7:1]	RESERVED		Reserved.	0x0	R
		0	DLL_LOCK		DLL lock indicator. This control reads back 1 if the DLL locks.	0x0	R
0x0C7	DLL_READ	[7:1]	RESERVED		Reserved.	0x0	R
		0	DLL_READ_EN		Enable DLL readback status. A transition of 0 to 1 updates the lock status bit readback in Register 0x0C3.	0x0	R/W
0x0CC	DLL_FINE_DELAY0	[7:6]	RESERVED		Reserved.	0x0	R
		[5:0]	DLL_FINE_DELAY0		DLL delay control.	0x0	R/W
0x0CD	DLL_FINE_DELAY1	[7:6]	RESERVED		Reserved.	0x0	R
		[5:0]	DLL_FINE_DELAY1		DLL delay control.	0x0	R/W
0x0DB	DLL_UPDATE	[7:1]	RESERVED		Reserved.	0x0	R
		0	DLL_DELAY_UPDATE		DLL update control. A transition from 0 to 1 updates the DLL circuitry with the current register control settings.	0x0	R/W

Addr.	Name	Bits	Bit Name	Settings	Description	Reset	Access
0x0FF	MOD_SWITCH_DEBUG	[7:2]	RESERVED		Reserved.	0x0	R
		1	CMPLX_MOD_DIV2_DISABLE		Disables the divide by 2 block in the modulator switch path. Set to 1 to bypass the divide by 2 block. This control is paged by the MAINDAC_PAGE bits in Register 0x008.	0x0	R/W
		0	RESERVED		Reserved.	0x0	R
0x100	DIG_RESET	[7:1]	RESERVED		Reserved.	0x0	R
		0	DIG_DATAPATH_PD	0 1	Holds all digital logic (SERDES digital, digital clock generation, and digital datapath) in reset until clock tree is stable. Normal operating mode. Holds the digital logic in reset. Must be released (set to 0) after clocks to the chip are stable (PLL and DLL blocks are locked) to use the digital datapath.	0x1	R/W
0x110	JESD_MODE	7	MODE_NOT_IN_TABLE		Programmed JESD204B mode and interpolation mode combination is not valid. Select a different combination.	0x0	R
		6	COM_SYNC		Combine the SYNCOUTx± signals in dual link case.	0x0	R/W
		[5:0]	JESD_MODE		Sets the JESD204B mode configuration. See Table 13 for the JESD204B supported operating modes and compatible interpolation rates. Bit 5 of this control determines single link (set to 0) or dual link (set to 1). Bits[4:0] set the desired JESD204B mode according to Table 13.	0x20	R/W
0x111	INTRP_MODE	[7:4]	DP_INTERP_MODE	0x1 0x2 0x4 0x6 0x8 0xC	Sets main datapath interpolation rate. See Table 13 for the JESD204B supported operating modes and compatible JESD204B modes and channel interpolation rates. 1×. 2×. 4×. 6×. 8×. 12×.	0x8	R/W
		[3:0]	CH_INTERP_MODE	0x1 0x2 0x3 0x4 0x6 0x8	Sets channel interpolation rate. See Table 13 for the JESD204B supported operating modes and compatible JESD204B modes and main datapath interpolation rates. 1×. 2×. 3×. 4×. 6×. 8×.	0x4	R/W

Addr.	Name	Bits	Bit Name	Settings	Description	Reset	Access
0x112	DDSM_DATAPATH_CFG	7	RESERVED		Reserved.	0x0	R
		6	EN_CMLX_MOD	0 1	Modulator switch mode selection. This control allows modifying Configuration 3 of the modulator switch to allow complex (I/Q) data from each NCO to pass to DACx. This function depends on the settings applied to Bits[5:4] in this register, Register 0x112. When this bit is set high, Bits[5:4] of this register are set to 0b11 (Modulator Switch Configuration 3). This control is paged by the MAINDAC_PAGE bits in Register 0x008.  Switch configuration is as defined by Bits[5:4].  With Bits[5:4] = 0b11 and the DAC1 main NCO enabled, DAC0 = I0_NCO + I1_NCO, DAC1 = Q0_NCO + Q1_NCO. With Bits[5:4] = 0b11 and the DAC1 main NCO disabled, DAC0 = I0_NCO, DAC1 = Q0_NCO.		
		[5:4]	DDSM_MODE	00 01 10 11	Modulator switch mode selection. This control chooses the mode of operation for the main datapath NCO being configured. This control is paged by the MAINDAC_PAGE bits in Register 0x008.  DAC0 = I0; DAC1 = I1. DAC0 = I0 + I1; DAC1 = Q0 + Q1. DAC0 = I0; DAC1 = Q0. DAC0 = I0 + I1; DAC1 = 0.	0x0	R/W
		3	DDSM_NCO_EN	0 1	Main datapath modulation enable. If the JESD204B mode chosen is a complex mode (main datapath interpolation >1x), this bit must be set to 1 for each main datapath being used. If no modulation is desired, set the FTW to be 0. This control is paged by the MAINDAC_PAGE bits in Register 0x008.  Disable main datapath NCO. Enable main datapath NCO.	0x0	R/W
		2	DDSM_MODULUS_EN	0 1	Enable main datapath modulus DDS. This control is paged by the MAINDAC_PAGE bits in Register 0x008.  Disable modulus DDS. Enable modulus DDS.	0x0	R/W
		1	DDSM_SEL_SIDE BAND	0 1	Selects upper or lower sideband from modulation result. This control is paged by the MAINDAC_PAGE bits in Register 0x008.  Use upper sideband. Use lower sideband = spectral flip.	0x0	R/W
		0	EN_SYNC_ALL_CHNL_NCO_RESETS	0 1	Selects the signal channel NCOS used for resets and FTW updates. This control is paged by the MAINDAC_PAGE bits in Register 0x008.  Channel NCOs reset or update their FTW based on channel NCO update requests. Channel NCOs reset or update their FTW based on main datapath NCO update requests.	0x1	R/W

Addr.	Name	Bits	Bit Name	Settings	Description	Reset	Access
0x113	DDSM_FTW_UPDATE	7	RESERVED		Reserved.	0x0	R
		[6:4]	DDSM_FTW_REQ_MODE	000	Frequency tuning word automatic update mode. This control is paged by the MAINDAC_PAGE bits in Register 0x008. No automatic requests are generated when the FTW registers are written.	0x0	R/W
				001	Automatically generates a DDSM_FTW_LOAD_REQ after DDSM_FTW Bits[7:0] are written.		
				010	Automatically generates a DDSM_FTW_LOAD_REQ after DDSM_FTW Bits[15:8] are written.		
				011	Automatically generates a DDSM_FTW_LOAD_REQ after DDSM_FTW Bits[23:16] are written.		
				100	Automatically generates a DDSM_FTW_LOAD_REQ after DDSM_FTW Bits[31:24] are written.		
				101	Automatically generate a DDSM_FTW_LOAD_REQ after DDSM_FTW Bits[39:32] is written.		
				110	Automatically generates a DDSM_FTW_LOAD_REQ after DDSM_FTW Bits[47:40] are written.		
		3	RESERVED		Reserved.	0x0	R
		2	DDSM_FTW_LOAD_SYSREF		Uses the next rising edge of SYSREF± to trigger FTW load and reset. This bit also loads the calibration tone FTW, as well as the main NCO FTW on a rising edge detection. This control is paged by the MAINDAC_PAGE bits in Register 0x008.	0x0	R/W
		1	DDSM_FTW_LOAD_ACK	0 1	Frequency tuning word update acknowledge. This bit reads back 1 if the FTW and phase offset word is loaded properly. This control is paged by the MAINDAC_PAGE bits in Register 0x008. FTW is not loaded. FTW is loaded.	0x0	R
		0	DDSM_FTW_LOAD_REQ	0 1	Frequency tuning word update request from the SPI. This bit also loads the calibration tone FTW, as well as the main NCO FTW on a rising edge detection. This control is paged by the MAINDAC_PAGE bits in Register 0x008. Clear DDSM_FTW_LOAD_ACK. 0 to 1 transition loads the FTW.	0x0	R/W
0x114	DDSM_FTW0	[7:0]	DDSM_FTW[7:0]		Sets the main datapath NCO FTW. If DDSM_MODULUS_EN is low, the main datapath NCO frequency = $f_{DAC} \times (\text{DDSM\_FTW}/2^{48})$ . If DDSM_MODULUS_EN is high, the main datapath NCO frequency = $f_{DAC} \times (\text{DDSM\_FTW} + \text{DDSM\_ACC\_DELTA}/\text{DDSM\_ACC\_MODULUS})/2^{48}$ . DDSM_ACC_DELTA must be >0. DDSM_ACC_DELTA must be >DDSM_ACC_MODULUS. This control is paged by the MAINDAC_PAGE bits in Register 0x008.	0x0	R/W

Addr.	Name	Bits	Bit Name	Settings	Description	Reset	Access
0x115	DDSM_FTW1	[7:0]	DDSM_FTW[15:8]		Sets the main datapath NCO FTW. If DDSM_MODULUS_EN is low, the main datapath NCO frequency = $f_{DAC} \times (DDSM\_FTW/2^{48})$ . If DDSM_MODULUS_EN is high, the main datapath NCO frequency = $f_{DAC} \times (DDSM\_FTW + DDSM\_ACC\_DELTA/DDS\_ACC\_MODULUS)/2^{48}$ . DDSM_ACC_DELTA must be > 0. DDSM_ACC_DELTA must be > DDSM_ACC_MODULUS. This control is paged by the MAINDAC_PAGE bits in Register 0x008.	0x0	R/W
0x116	DDSM_FTW2	[7:0]	DDSM_FTW[23:16]		Sets the main datapath NCO FTW. If DDSM_MODULUS_EN is low, the main datapath NCO frequency = $f_{DAC} \times (DDSM\_FTW/2^{48})$ . If DDSM_MODULUS_EN is high, the main datapath NCO frequency = $f_{DAC} \times (DDSM\_FTW + DDSM\_ACC\_DELTA/DDS\_ACC\_MODULUS)/2^{48}$ . DDSM_ACC_DELTA must be > 0. DDSM_ACC_DELTA must be > DDSM_ACC_MODULUS. This control is paged by the MAINDAC_PAGE bits in Register 0x008.	0x0	R/W
0x117	DDSM_FTW3	[7:0]	DDSM_FTW[31:24]		Sets the main datapath NCO FTW. If DDSM_MODULUS_EN is low, the main datapath NCO frequency = $f_{DAC} \times (DDSM\_FTW/2^{48})$ . If DDSM_MODULUS_EN is high, the main datapath NCO frequency = $f_{DAC} \times (DDSM\_FTW + DDSM\_ACC\_DELTA/DDS\_ACC\_MODULUS)/2^{48}$ . DDSM_ACC_DELTA must be > 0. DDSM_ACC_DELTA must be > DDSM_ACC_MODULUS. This control is paged by the MAINDAC_PAGE bits in Register 0x008.	0x0	R/W
0x118	DDSM_FTW4	[7:0]	DDSM_FTW[39:32]		Sets the main datapath NCO FTW. If DDSM_MODULUS_EN is low, the main datapath NCO frequency = $f_{DAC} \times (DDSM\_FTW/2^{48})$ . If DDSM_MODULUS_EN is high, the main datapath NCO frequency = $f_{DAC} \times (DDSM\_FTW + DDSM\_ACC\_DELTA/DDS\_ACC\_MODULUS)/2^{48}$ . DDSM_ACC_DELTA must be > 0. DDSM_ACC_DELTA must be > DDSM_ACC_MODULUS. This control is paged by the MAINDAC_PAGE bits in Register 0x008.	0x0	R/W
0x119	DDSM_FTW5	[7:0]	DDSM_FTW[47:40]		Sets the main datapath NCO FTW. If DDSM_MODULUS_EN is low, the main datapath NCO frequency = $f_{DAC} \times (DDSM\_FTW/2^{48})$ . If DDSM_MODULUS_EN is high, the main datapath NCO frequency = $f_{DAC} \times (DDSM\_FTW + DDSM\_ACC\_DELTA/DDS\_ACC\_MODULUS)/2^{48}$ . DDSM_ACC_DELTA must be > 0. DDSM_ACC_DELTA must be > DDSM_ACC_MODULUS. This control is paged by the MAINDAC_PAGE bits in Register 0x008.	0x0	R/W
0x11C	DDSM_PHASE_OFFSET0	[7:0]	DDSM_NCO_PHASE_OFFSET[7:0]		Sets main datapath NCO phase offset. Code is in 16-bit, twos complement format. Degrees offset = $180 \times (\text{code}/2^{15})$ . This control is paged by the MAINDAC_PAGE bits in Register 0x008.	0x0	R/W

Addr.	Name	Bits	Bit Name	Settings	Description	Reset	Access
0x11D	DDSM_PHASE_OFFSET1	[7:0]	DDSM_NCO_PHASE_OFFSET[15:8]		Sets main datapath NCO phase offset. Code is in 16-bit, twos complement format. Degrees offset = $180 \times (\text{code}/2^{15})$ . This control is paged by the MAINDAC_PAGE bits in Register 0x008.	0x0	R/W
0x124	DDSM_ACC_MODULUS0	[7:0]	DDSM_ACC_MODULUS[7:0]		Sets DDSM_ACC_MODULUS. If DDSM_MODULUS_EN is high, the main datapath NCO frequency = $f_{DAC} \times (\text{DDSM\_FTW} + \text{DDSM\_ACC\_DELTA}/\text{DDSM\_ACC\_MODULUS})/2^{48}$ . DDSM_ACC_DELTA must be >0. DDSM_ACC_DELTA must be > DDSM_ACC_MODULUS. This control is paged by the MAINDAC_PAGE bits in Register 0x008.	0x0	R/W
0x125	DDSM_ACC_MODULUS1	[7:0]	DDSM_ACC_MODULUS[15:8]		Sets DDSM_ACC_MODULUS. If DDSM_MODULUS_EN is high, the main datapath NCO frequency = $f_{DAC} \times (\text{DDSM\_FTW} + \text{DDSM\_ACC\_DELTA}/\text{DDSM\_ACC\_MODULUS})/2^{48}$ . DDSM_ACC_DELTA must be >0. DDSM_ACC_DELTA must be > DDSM_ACC_MODULUS. This control is paged by the MAINDAC_PAGE bits in Register 0x008.	0x0	R/W
0x126	DDSM_ACC_MODULUS2	[7:0]	DDSM_ACC_MODULUS[23:16]		Sets DDSM_ACC_MODULUS. If DDSM_MODULUS_EN is high, the main datapath NCO frequency = $f_{DAC} \times (\text{DDSM\_FTW} + \text{DDSM\_ACC\_DELTA}/\text{DDSM\_ACC\_MODULUS})/2^{48}$ . DDSM_ACC_DELTA must be >0. DDSM_ACC_DELTA must be > DDSM_ACC_MODULUS. This control is paged by the MAINDAC_PAGE bits in Register 0x008.	0x0	R/W
0x127	DDSM_ACC_MODULUS3	[7:0]	DDSM_ACC_MODULUS[31:24]		Sets DDSM_ACC_MODULUS. If DDSM_MODULUS_EN is high, the main datapath NCO frequency = $f_{DAC} \times (\text{DDSM\_FTW} + \text{DDSM\_ACC\_DELTA}/\text{DDSM\_ACC\_MODULUS})/2^{48}$ . DDSM_ACC_DELTA must be >0. DDSM_ACC_DELTA must be > DDSM_ACC_MODULUS. This control is paged by the MAINDAC_PAGE bits in Register 0x008.	0x0	R/W
0x128	DDSM_ACC_MODULUS4	[7:0]	DDSM_ACC_MODULUS[39:32]		Sets DDSM_ACC_MODULUS. If DDSM_MODULUS_EN is high, the main datapath NCO frequency = $f_{DAC} \times (\text{DDSM\_FTW} + \text{DDSM\_ACC\_DELTA}/\text{DDSM\_ACC\_MODULUS})/2^{48}$ . DDSM_ACC_DELTA must be >0. DDSM_ACC_DELTA must be > DDSM_ACC_MODULUS. This control is paged by the MAINDAC_PAGE bits in Register 0x008.	0x0	R/W
0x129	DDSM_ACC_MODULUS5	[7:0]	DDSM_ACC_MODULUS[47:40]		Sets DDSM_ACC_MODULUS. If DDSM_MODULUS_EN is high, the main datapath NCO frequency = $f_{DAC} \times (\text{DDSM\_FTW} + \text{DDSM\_ACC\_DELTA}/\text{DDSM\_ACC\_MODULUS})/2^{48}$ . DDSM_ACC_DELTA must be >0. DDSM_ACC_DELTA must be > DDSM_ACC_MODULUS. This control is paged by the MAINDAC_PAGE bits in Register 0x008.	0x0	R/W
0x12A	DDSM_ACC_DELTA0	[7:0]	DDSM_ACC_DELTA[7:0]		Sets DDSM_ACC_DELTA. If DDSM_MODULUS_EN is high, main datapath NCO frequency = $f_{DAC} \times (\text{DDSM\_FTW} + \text{DDSM\_ACC\_DELTA}/\text{DDSM\_ACC\_MODULUS})/2^{48}$ . DDSM_ACC_DELTA must be > 0. DDSM_ACC_DELTA must be > DDSM_ACC_MODULUS. This control is paged by the MAINDAC_PAGE bits in Register 0x008.	0x0	R/W

Addr.	Name	Bits	Bit Name	Settings	Description	Reset	Access
0x12B	DDSM_ACC_DELTA1	[7:0]	DDSM_ACC_DELTA[15:8]		Sets DDSM_ACC_DELTA. If DDSM_MODULUS_EN is high, main datapath NCO frequency = $f_{DAC} \times (DDSM\_FTW + DDSM\_ACC\_DELTA/DDS\_MODULUS)/2^{48}$ . DDSM_ACC_DELTA must be > 0. DDSM_ACC_DELTA must be > DDSM_ACC_MODULUS. This control is paged by the MAINDAC_PAGE bits in Register 0x008.	0x0	R/W
0x12C	DDSM_ACC_DELTA2	[7:0]	DDSM_ACC_DELTA[23:16]		Sets DDSM_ACC_DELTA. If DDSM_MODULUS_EN is high, main datapath NCO frequency = $f_{DAC} \times (DDSM\_FTW + DDSM\_ACC\_DELTA/DDS\_MODULUS)/2^{48}$ . DDSM_ACC_DELTA must be > 0. DDSM_ACC_DELTA must be > DDSM_ACC_MODULUS. This control is paged by the MAINDAC_PAGE bits in Register 0x008.	0x0	R/W
0x12D	DDSM_ACC_DELTA3	[7:0]	DDSM_ACC_DELTA[31:24]		Sets DDSM_ACC_DELTA. If DDSM_MODULUS_EN is high, main datapath NCO frequency = $f_{DAC} \times (DDSM\_FTW + DDSM\_ACC\_DELTA/DDS\_MODULUS)/2^{48}$ . DDSM_ACC_DELTA must be > 0. DDSM_ACC_DELTA must be > DDSM_ACC_MODULUS. This control is paged by the MAINDAC_PAGE bits in Register 0x008.	0x0	R/W
0x12E	DDSM_ACC_DELTA4	[7:0]	DDSM_ACC_DELTA[39:32]		Sets DDSM_ACC_DELTA. If DDSM_MODULUS_EN is high, main datapath NCO frequency = $f_{DAC} \times (DDSM\_FTW + DDSM\_ACC\_DELTA/DDS\_MODULUS)/2^{48}$ . DDSM_ACC_DELTA must be > 0. DDSM_ACC_DELTA must be > DDSM_ACC_MODULUS. This control is paged by the MAINDAC_PAGE bits in Register 0x008.	0x0	R/W
0x12F	DDSM_ACC_DELTA5	[7:0]	DDSM_ACC_DELTA[47:40]		Sets DDSM_ACC_DELTA. If DDSM_MODULUS_EN is high, main datapath NCO frequency = $f_{DAC} \times (DDSM\_FTW + DDSM\_ACC\_DELTA/DDS\_MODULUS)/2^{48}$ . DDSM_ACC_DELTA must be > 0. DDSM_ACC_DELTA must be > DDSM_ACC_MODULUS. This control is paged by the MAINDAC_PAGE bits in Register 0x008.	0x0	R/W
0x130	DDSC_DATAPATH_CFG	7	RESERVED		Reserved.	0x0	R
		6	DDSC_NCO_EN	0	Disable channel NCO.	0x0	R/W
				1	Enable channel NCO.		
		[5:3]	RESERVED		Reserved.	0x0	R/W
2	DDSC_MODULUS_EN	0	Disable modulus DDS.	0x0	R/W		
		1	Enable modulus DDS.				

Addr.	Name	Bits	Bit Name	Settings	Description	Reset	Access
		1	DDSC_SEL_SIDE BAND	0 1	Selects upper or lower sideband from modulation result. This control is paged by the CHANNEL_PAGE bits in Register 0x008. Use upper sideband. Use lower sideband = spectral flip.	0x0	R/W
		0	DDSC_EN_DC_INPUT	0 1	Enable test tone generation by sending dc to input level to channel DDS. Set the amplitude in the DC_TEST_INPUT_AMPLITUDE control (Register 0x148 and Register 0x149). This control is paged by the CHANNEL_PAGE bits in Register 0x008. Disable test tone generation. Enable test tone generation.	0x0	R/W
0x131	DDSC_FTW_UPDATE	[7:3]	RESERVED		Reserved.	0x0	R
		2	DDSC_FTW_LOAD_SYSREF		Use next rising edge of SYSREF± to trigger FTW load and reset. This control is paged by the CHANNEL_PAGE bits in Register 0x008.	0x0	R/W
		1	DDSC_FTW_LOAD_ACK	0 1	Frequency tuning word update acknowledge bit. This bit reads back 1 if the FTW and phase offset word is loaded properly. This control is paged by the CHANNEL_PAGE bits in Register 0x008. FTW is not loaded. FTW is loaded.	0x0	R
		0	DDSC_FTW_LOAD_REQ	0 1	Frequency tuning word update request from the SPI. This control is paged by the CHANNEL_PAGE bits in Register 0x008. No FTW update. 0 to 1 transition loads the FTW.	0x0	R/W
0x132	DDSC_FTW0	[7:0]	DDSC_FTW[7:0]		Sets the channel datapath NCO FTW. If DDSC_MODULUS_EN is low, the main datapath NCO frequency = $f_{DAC} \times (DDSC\_FTW/2^{48})$ . If DDSC_MODULUS_EN is high, main datapath NCO frequency = $f_{DAC} \times (DDSC\_FTW + DDSC\_ACC\_DELTA/DDSC\_ACC\_MODULUS)/2^{48}$ . DDSC_ACC_DELTA must be > 0. DDSC_ACC_DELTA must be > DDSC_ACC_MODULUS. This control is paged by the CHANNEL_PAGE bits in Register 0x008.	0x0	R/W
0x133	DDSC_FTW1	[7:0]	DDSC_FTW[15:8]		Sets the channel datapath NCO FTW. If DDSC_MODULUS_EN is low, the main datapath NCO frequency = $f_{DAC} \times (DDSC\_FTW/2^{48})$ . If DDSC_MODULUS_EN is high, main datapath NCO frequency = $f_{DAC} \times (DDSC\_FTW + DDSC\_ACC\_DELTA/DDSC\_ACC\_MODULUS)/2^{48}$ . DDSC_ACC_DELTA must be > 0. DDSC_ACC_DELTA must be > DDSC_ACC_MODULUS. This control is paged by the CHANNEL_PAGE bits in Register 0x008.	0x0	R/W

Addr.	Name	Bits	Bit Name	Settings	Description	Reset	Access
0x134	DDSC_FTW2	[7:0]	DDSC_FTW[23:16]		Sets the channel datapath NCO FTW. If DDSC_MODULUS_EN is low, the main datapath NCO frequency = $f_{DAC} \times (DDSC\_FTW/2^{48})$ . If DDSC_MODULUS_EN is high, main datapath NCO frequency = $f_{DAC} \times (DDSC\_FTW + DDSC\_ACC\_DELTA/DDSC\_ACC\_MODULUS)/2^{48}$ . DDSC_ACC_DELTA must be > 0. DDSC_ACC_DELTA must be > DDSC_ACC_MODULUS. This control is paged by the CHANNEL_PAGE bits in Register 0x008.	0x0	R/W
0x135	DDSC_FTW3	[7:0]	DDSC_FTW[31:24]		Sets the channel datapath NCO FTW. If DDSC_MODULUS_EN is low, the main datapath NCO frequency = $f_{DAC} \times (DDSC\_FTW/2^{48})$ . If DDSC_MODULUS_EN is high, main datapath NCO frequency = $f_{DAC} \times (DDSC\_FTW + DDSC\_ACC\_DELTA/DDSC\_ACC\_MODULUS)/2^{48}$ . DDSC_ACC_DELTA must be > 0. DDSC_ACC_DELTA must be > DDSC_ACC_MODULUS. This control is paged by the CHANNEL_PAGE bits in Register 0x008.	0x0	R/W
0x136	DDSC_FTW4	[7:0]	DDSC_FTW[39:32]		Sets the channel datapath NCO FTW. If DDSC_MODULUS_EN is low, the main datapath NCO frequency = $f_{DAC} \times (DDSC\_FTW/2^{48})$ . If DDSC_MODULUS_EN is high, main datapath NCO frequency = $f_{DAC} \times (DDSC\_FTW + DDSC\_ACC\_DELTA/DDSC\_ACC\_MODULUS)/2^{48}$ . DDSC_ACC_DELTA must be > 0. DDSC_ACC_DELTA must be > DDSC_ACC_MODULUS. This control is paged by the CHANNEL_PAGE bits in Register 0x008.	0x0	R/W
0x137	DDSC_FTW5	[7:0]	DDSC_FTW[47:40]		Sets the channel datapath NCO FTW. If DDSC_MODULUS_EN is low, the main datapath NCO frequency = $f_{DAC} \times (DDSC\_FTW/2^{48})$ . If DDSC_MODULUS_EN is high, main datapath NCO frequency = $f_{DAC} \times (DDSC\_FTW + DDSC\_ACC\_DELTA/DDSC\_ACC\_MODULUS)/2^{48}$ . DDSC_ACC_DELTA must be > 0. DDSC_ACC_DELTA must be > DDSC_ACC_MODULUS. This control is paged by the CHANNEL_PAGE bits in Register 0x008.	0x0	R/W
0x138	DDSC_PHASE_OFFSET0	[7:0]	DDSC_NCO_PHASE_OFFSET[7:0]		Sets the channel NCO phase offset. Code is in 16-bit, twos complement format. Degrees offset = $180 \times (\text{code}/2^{15})$ . This control is paged by the CHANNEL_PAGE bits in Register 0x008.	0x0	R/W
0x139	DDSC_PHASE_OFFSET1	[7:0]	DDSC_NCO_PHASE_OFFSET[15:8]		Sets the channel NCO phase offset. Code is in 16-bit, twos complement format. Degrees offset = $180 \times (\text{code}/2^{15})$ . This control is paged by the CHANNEL_PAGE bits in Register 0x008.	0x0	R/W
0x13A	DDSC_ACC_MODULUS0	[7:0]	DDSC_ACC_MODULUS[7:0]		Sets DDSC_ACC_MODULUS. If DDSC_MODULUS_EN is high, the main datapath NCO frequency = $f_{DAC} \times (DDSC\_FTW + DDSC\_ACC\_DELTA/DDSC\_ACC\_MODULUS)/2^{48}$ . DDSC_ACC_DELTA must be > 0. DDSC_ACC_DELTA must be > DDSC_ACC_MODULUS. This control is paged by the CHANNEL_PAGE bits in Register 0x008.	0x0	R/W

Addr.	Name	Bits	Bit Name	Settings	Description	Reset	Access
0x13B	DDSC_ACC_MODULUS1	[7:0]	DDSC_ACC_MODULUS[15:8]		Sets DDSC_ACC_MODULUS. If DDSC_MODULUS_EN is high, the main datapath NCO frequency = $f_{DAC} \times (DDSC\_FTW + DDSC\_ACC\_DELTA/DDSC\_ACC\_MODULUS)/2^{48}$ . DDSC_ACC_DELTA must be > 0. DDSC_ACC_DELTA must be > DDSC_ACC_MODULUS. This control is paged by the CHANNEL_PAGE bits in Register 0x008.	0x0	R/W
0x13C	DDSC_ACC_MODULUS2	[7:0]	DDSC_ACC_MODULUS[23:16]		Sets DDSC_ACC_MODULUS. If DDSC_MODULUS_EN is high, the main datapath NCO frequency = $f_{DAC} \times (DDSC\_FTW + DDSC\_ACC\_DELTA/DDSC\_ACC\_MODULUS)/2^{48}$ . DDSC_ACC_DELTA must be > 0. DDSC_ACC_DELTA must be > DDSC_ACC_MODULUS. This control is paged by the CHANNEL_PAGE bits in Register 0x008.	0x0	R/W
0x13D	DDSC_ACC_MODULUS3	[7:0]	DDSC_ACC_MODULUS[31:24]		Sets DDSC_ACC_MODULUS. If DDSC_MODULUS_EN is high, the main datapath NCO frequency = $f_{DAC} \times (DDSC\_FTW + DDSC\_ACC\_DELTA/DDSC\_ACC\_MODULUS)/2^{48}$ . DDSC_ACC_DELTA must be > 0. DDSC_ACC_DELTA must be > DDSC_ACC_MODULUS. This control is paged by the CHANNEL_PAGE bits in Register 0x008.	0x0	R/W
0x13E	DDSC_ACC_MODULUS4	[7:0]	DDSC_ACC_MODULUS[39:32]		Sets DDSC_ACC_MODULUS. If DDSC_MODULUS_EN is high, the main datapath NCO frequency = $f_{DAC} \times (DDSC\_FTW + DDSC\_ACC\_DELTA/DDSC\_ACC\_MODULUS)/2^{48}$ . DDSC_ACC_DELTA must be > 0. DDSC_ACC_DELTA must be > DDSC_ACC_MODULUS. This control is paged by the CHANNEL_PAGE bits in Register 0x008.	0x0	R/W
0x13F	DDSC_ACC_MODULUS5	[7:0]	DDSC_ACC_MODULUS[47:40]		Sets DDSC_ACC_MODULUS. If DDSC_MODULUS_EN is high, the main datapath NCO frequency = $f_{DAC} \times (DDSC\_FTW + DDSC\_ACC\_DELTA/DDSC\_ACC\_MODULUS)/2^{48}$ . DDSC_ACC_DELTA must be > 0. DDSC_ACC_DELTA must be > DDSC_ACC_MODULUS. This control is paged by the CHANNEL_PAGE bits in Register 0x008.	0x0	R/W
0x140	DDSC_ACC_DELTA0	[7:0]	DDSC_ACC_DELTA[7:0]		Sets DDSC_ACC_DELTA. If DDSC_MODULUS_EN is high, the main datapath NCO frequency = $f_{DAC} \times (DDSC\_FTW + DDSC\_ACC\_DELTA/DDSC\_ACC\_MODULUS)/2^{48}$ . DDSC_ACC_DELTA must be > 0. DDSC_ACC_DELTA must be > DDSC_ACC_MODULUS. This control is paged by the CHANNEL_PAGE bits in Register 0x008.	0x0	R/W
0x141	DDSC_ACC_DELTA1	[7:0]	DDSC_ACC_DELTA[15:8]		Sets DDSC_ACC_DELTA. If DDSC_MODULUS_EN is high, the main datapath NCO frequency = $f_{DAC} \times (DDSC\_FTW + DDSC\_ACC\_DELTA/DDSC\_ACC\_MODULUS)/2^{48}$ . DDSC_ACC_DELTA must be > 0. DDSC_ACC_DELTA must be > DDSC_ACC_MODULUS. This control is paged by the CHANNEL_PAGE bits in Register 0x008.	0x0	R/W

Addr.	Name	Bits	Bit Name	Settings	Description	Reset	Access
0x142	DDSC_ACC_DELTA2	[7:0]	DDSC_ACC_DELTA[23:16]		Sets DDSC_ACC_DELTA. If DDSC_MODULUS_EN is high, the main datapath NCO frequency = $f_{DAC} \times (DDSC\_FTW + DDSC\_ACC\_DELTA/DDSC\_ACC\_MODULUS)/2^{48}$ . DDSC_ACC_DELTA must be > 0. DDSC_ACC_DELTA must be > DDSC_ACC_MODULUS. This control is paged by the CHANNEL_PAGE bits in Register 0x008.	0x0	R/W
0x143	DDSC_ACC_DELTA3	[7:0]	DDSC_ACC_DELTA[31:24]		Sets DDSC_ACC_DELTA. If DDSC_MODULUS_EN is high, the main datapath NCO frequency = $f_{DAC} \times (DDSC\_FTW + DDSC\_ACC\_DELTA/DDSC\_ACC\_MODULUS)/2^{48}$ . DDSC_ACC_DELTA must be > 0. DDSC_ACC_DELTA must be > DDSC_ACC_MODULUS. This control is paged by the CHANNEL_PAGE bits in Register 0x008.	0x0	R/W
0x144	DDSC_ACC_DELTA4	[7:0]	DDSC_ACC_DELTA[39:32]		Sets DDSC_ACC_DELTA. If DDSC_MODULUS_EN is high, the main datapath NCO frequency = $f_{DAC} \times (DDSC\_FTW + DDSC\_ACC\_DELTA/DDSC\_ACC\_MODULUS)/2^{48}$ . DDSC_ACC_DELTA must be > 0. DDSC_ACC_DELTA must be > DDSC_ACC_MODULUS. This control is paged by the CHANNEL_PAGE bits in Register 0x008.	0x0	R/W
0x145	DDSC_ACC_DELTA5	[7:0]	DDSC_ACC_DELTA[47:40]		Sets DDSC_ACC_DELTA. If DDSC_MODULUS_EN is high, the main datapath NCO frequency = $f_{DAC} \times (DDSC\_FTW + DDSC\_ACC\_DELTA/DDSC\_ACC\_MODULUS)/2^{48}$ . DDSC_ACC_DELTA must be > 0. DDSC_ACC_DELTA must be > DDSC_ACC_MODULUS. This control is paged by the CHANNEL_PAGE bits in Register 0x008.	0x0	R/W
0x146	CHNL_GAIN0	[7:0]	CHNL_GAIN[7:0]		Sets the scalar channel gain value. This control is paged by the CHANNEL_PAGE bits in Register 0x008. Channel gain = $CHNL\_GAIN/2^{11}$ .	0x0	R/W
0x147	CHNL_GAIN1	[7:4]	RESERVED		Reserved.	0x0	R
		[3:0]	CHNL_GAIN[11:8]		Sets the scalar channel gain value. This control is paged by the CHANNEL_PAGE bits in Register 0x008. Channel gain = $CHNL\_GAIN/2^{11}$ .	0x8	R/W
0x148	DC_CAL_TONE0	[7:0]	DC_TEST_INPUT_AMPLITUDE[7:0]		DC test tone amplitude. This value sets the I path and Q paths amplitudes independently. Set these bits to 0x50FF for a full-scale tone and ensure DDSC_EN_DC_INPUT in Register 0x130 Bit 0 is set to 1. This control is paged by the CHANNEL_PAGE control in Register 0x008.	0x0	R/W
0x149	DC_CAL_TONE1	[7:0]	DC_TEST_INPUT_AMPLITUDE[15:8]		DC test tone amplitude. This value sets the I path and Q paths amplitudes independently. Set to 0x50FF for a full-scale tone and ensure that DDSC_EN_DC_INPUT (Register 0x130, Bit 0) is set to 1. This control is paged by the CHANNEL_PAGE bits in Register 0x008.	0x0	R/W

Addr.	Name	Bits	Bit Name	Settings	Description	Reset	Access
0x14B	PRBS	7	PRBS_GOOD_Q	1	DAC1 good data indicator. Correct PRBS sequence detected.	0x0	R
				0	Incorrect sequence detected. Sticky; reset to 1 by PRBS_RESET.		
		6	PRBS_GOOD_I	0	DAC0 good data indicator. Incorrect sequence detected. Sticky; reset to 1 by PRBS_RESET.	0x0	R
				1	Correct PRBS sequence detected.		
		5	RESERVED		Reserved.	0x0	R
		4	PRBS_INV_Q	0	DAC1 data inversion. Expect normal data.	0x1	R/W
				1	Expect inverted data.		
		3	PRBS_INV_I	0	DAC0 data inversion. Expect normal data.	0x0	R/W
1	Expect inverted data.						
2	PRBS_MODE	0	Select which PRBS polynomial is used for the datapath PRBS test. 7-bit: $x^7 + x^6 + 1$ .	0x0	R/W		
		1	15-bit: $x^{15} + x^{14} + 1$ .				
1	PRBS_RESET	0	Reset error counters. Normal operation.	0x0	R/W		
		1	Reset counters.				
0	PRBS_EN	0	Enable PRBS checker. Disable.	0x0	R/W		
		1	Enable.				
0x14C	PRBS_ERROR_I	[7:0]	PRBS_COUNT_I		DAC0 PRBS error count.	0x0	R
0x14D	PRBS_ERROR_Q	[7:0]	PRBS_COUNT_Q		DAC1 PRBS error count.	0x0	R
0x14E	PRBS_CHANSEL	[7:3]	RESERVED		Reserved.	0x0	R
		[2:0]	PRBS_CHANSEL	0	Selects the channel to which the PRBS_GOOD_x and PRBS_COUNT_x bit field readbacks correspond. Select Channel 0 for PRBS_COUNT_x and PRBS_GOOD_x (Channel 0, DAC0).	0x7	R/W
1	Select Channel 1 for PRBS_COUNT_x and PRBS_GOOD_x (Channel 1, DAC0).						
2	Select Channel 2 for PRBS_COUNT_x and PRBS_GOOD_x (Channel 2, DAC0).						
3	Select Channel 3 for PRBS_COUNT_x and PRBS_GOOD_x (Channel 0, DAC1).						
4	Select Channel 4 for PRBS_COUNT_x and PRBS_GOOD_x (Channel 1, DAC1).						
5	Select Channel 5 for PRBS_COUNT_x and PRBS_GOOD_x (Channel 2, DAC1).						
6	OR all channels for PRBS_GOOD_x, sum all channels for PRBS_COUNT_x.						
0x151	DECODE_MODE	[7:5]	RESERVED		Reserved.	0x0	R
		4	MSB_SHUFFLE_EN		MSB shuffle control. Set =1 to enable shuffling the MSBs, or set = 0 to disable MSB shuffle and use the default (static) thermometer encoding instead.	0x0	R/W
		[3:0]	RESERVED		Reserved.	0x0	R
0x1DE	SPI_ENABLE	[7:2]	RESERVED		Reserved.	0x0	R
		1	SPI_EN1		Enable SPI control.	0x1	R/W
		0	SPI_EN0		Enable SPI control.	0x1	R/W

Addr.	Name	Bits	Bit Name	Settings	Description	Reset	Access
0x1E2	DDSM_CAL_FTW0	[7:0]	DDSM_CAL_FTW[7:0]		FTW of the calibration accumulator. This control is paged by the MAINDAC_PAGE bits in Register 0x008.	0x0	R/W
0x1E3	DDSM_CAL_FTW1	[7:0]	DDSM_CAL_FTW[15:8]		FTW of the calibration accumulator. This control is paged by the MAINDAC_PAGE bits in Register 0x008.	0x0	R/W
0x1E4	DDSM_CAL_FTW2	[7:0]	DDSM_CAL_FTW[23:16]		FTW of the calibration accumulator. This control is paged by the MAINDAC_PAGE bits in Register 0x008.	0x0	R/W
0x1E5	DDSM_CAL_FTW3	[7:0]	DDSM_CAL_FTW[31:24]		FTW of the calibration accumulator. This control is paged by the MAINDAC_PAGE bits in Register 0x008.	0x0	R/W
0x1E6	DDSM_CAL_MODE_DEF	[7:3]	RESERVED		Reserved.	0x0	R
		2	DDSM_EN_CAL_ACC	0 1	Enable clock calibration accumulator. This bit must be first set high, and then must load the calibration FTW into Register 0x1E2 to Register 0x1E5 to take effect. This control is paged by the MAINDAC_PAGE bits in Register 0x008. Disabled (does not clock the calibration frequency accumulator). Enables (turns on the clock to the calibration frequency accumulator).	0x0	R/W
		1	DDSM_EN_CAL_DC_INPUT	0 1	Enable dc input to calibration DDS. This control is paged by the MAINDAC_PAGE bits in Register 0x008. Mux in datapath signal to the input of the final DDS. Mux in dc to the input of the final DDS.	0x0	R/W
		0	DDSM_EN_CAL_FREQ_TUNE	0 1	Enable tuning of the signal to calibration frequency for DAC0 only. This control is paged by the MAINDAC_PAGE bits in Register 0x008. Disable calibration frequency tuning. Enable calibration frequency tuning.	0x0	R/W
0x1E7	DATAPATH_NCO_SYNC_CFG	[7:2]	RESERVED		Reserved.	0x0	R
		1	ALL_NCO_SYNC_ACK		Acknowledge signal that all the active NCOs are loaded. This bit is the acknowledge indicator for both the START_NCO_SYNC bit (Bit 0 of this register) and the NCORST_AFTER_ROT_EN bit (Register 0x03B, Bit 4) method of resetting the NCOs. This control is paged by the MAINDAC_PAGE bits in Register 0x008.	0x0	R
		0	START_NCO_SYNC		Used to start the sync of the NCOs on a rising edge of the SPI bit or SYSREF± signal, depending on which is chosen as the update trigger. Upon receiving a trigger, the FTWs are loaded first, and then a synchronization occurs. This control is paged by the MAINDAC_PAGE bits in Register 0x008.	0x0	R/W
0x200	MASTER_PD	[7:1]	RESERVED		Reserved.	0x0	R
		0	SERDES_MASTER_PD		Powers down the entire JESD204B receiver analog (all eight channels and bias).	0x1	R/W

Addr.	Name	Bits	Bit Name	Settings	Description	Reset	Access
0x201	PHY_PD	[7:0]	PHY_PD		SPI override to power down the individual PHYs. Bit 0 controls the SERDIN0± PHY. Bit 1 controls the SERDIN1± PHY. Bit 2 controls the SERDIN2± PHY. Bit 3 controls the SERDIN3± PHY. Bit 4 controls the SERDIN4± PHY. Bit 5 controls the SERDIN5± PHY. Bit 6 controls the SERDIN6± PHY. Bit 7 controls the SERDIN7± PHY.	0xEE	R/W
0x203	GENERIC_PD	[7:2]	RESERVED		Reserved.	0x0	R
		1	PD_SYNCOUT0	0 1	Powers down the SYNCOUT0± driver. Enables the SYNCOUT0± output pins. Powers down the SYNCOUT0± output pins.	0x0	R/W
		0	PD_SYNCOUT1	0 1	Powers down the SYNCOUT1± driver. Enables the SYNCOUT1± output pins. Powers down the SYNCOUT1± output pins.	0x1	R/W
0x206	CDR_RESET	[7:1]	RESERVED		Reserved.	0x0	R
		0	CDR_PHY_RESET		PHY reset control bit. Set this bit to 1 to take the PHYs out of reset during device operation.	0x0	R/W
0x210	CBUS_ADDR	[7:0]	SERDES_CBUS_ADDR		SERDES configuration control register to set SERDES configuration address controls.	0x0	R/W
0x212	CBUS_WRSTROBE_PHY	[7:0]	SERDES_CBUS_WR0		SERDES configuration control register to commit the SERDES configuration controls written.	0x0	R/W
0x213	CBUS_WRSTROBE_OTHER	[7:1]	RESERVED		Reserved.	0x0	R
		0	SERDES_CBUS_WR1		SERDES configuration control register to commit the SERDES configuration controls written.	0x0	R/W
0x216	CBUS_WDATA	[7:0]	SERDES_CBUS_DATA		SERDES configuration control register to set the SERDES configuration control data.	0x0	R/W
0x240	EQ_BOOST_PHY_3_0	[7:6]	EQ_BOOST_PHY3	10 11	Equalizer setting for PHY 3 based on insertion loss of the system. Insertion loss ≤ 11 dB. Insertion loss > 11 dB.	0x3	R/W
		[5:4]	EQ_BOOST_PHY2	10 11	Equalizer setting for PHY 2 based on insertion loss of the system. Insertion loss ≤ 11 dB. Insertion loss > 11 dB.	0x3	R/W
		[3:2]	EQ_BOOST_PHY1	10 11	Equalizer setting for PHY 1 based on insertion loss of the system. Insertion loss ≤ 11 dB. Insertion loss > 11 dB.	0x3	R/W
		[1:0]	EQ_BOOST_PHY0	10 11	Equalizer setting for PHY 0 based on insertion loss of the system. Insertion loss ≤ 11 dB. Insertion loss > 11 dB.	0x3	R/W
0x234	CDR_BITINVERSE	[7:0]	SEL_IF_PARDATAINV_DES_RC_CH	0 1	Output data inversion bit controls. Set Bit x corresponding to PHY x to invert the bit polarity. Not inverted. Inverted.	0x66	R/W

Addr.	Name	Bits	Bit Name	Settings	Description	Reset	Access
0x241	EQ_BOOST_PHY_7_4	[7:6]	EQ_BOOST_PHY7	10 11	Equalizer setting for PHY 7 based on insertion loss of the system. Insertion loss ≤ 11 dB. Insertion loss > 11 dB.	0x3	R/W
		[5:4]	EQ_BOOST_PHY6	10 11	Equalizer setting for PHY 6 based on insertion loss of the system. Insertion loss ≤ 11 dB. Insertion loss > 11 dB.	0x3	R/W
		[3:2]	EQ_BOOST_PHY5	10 11	Equalizer setting for PHY 5 based on insertion loss of the system. Insertion loss ≤ 11 dB. Insertion loss > 11 dB.	0x3	R/W
		[1:0]	EQ_BOOST_PHY4	10 11	Equalizer setting for PHY 4 based on insertion loss of the system. Insertion loss ≤ 11 dB. Insertion loss > 11 dB.	0x3	R/W
0x242	EQ_GAIN_PHY_3_0	[7:6]	EQ_GAIN_PHY3	01 11	Equalizer gain for PHY 3 based on insertion loss of the system. Insertion loss ≤ 11 dB. Insertion loss > 11 dB.	0x3	R/W
		[5:4]	EQ_GAIN_PHY2	01 11	Equalizer gain for PHY 2 based on insertion loss of the system. Insertion loss ≤ 11 dB. Insertion loss > 11 dB.	0x3	R/W
		[3:2]	EQ_GAIN_PHY1	01 11	Equalizer gain for PHY 1 based on insertion loss of the system. Insertion loss ≤ 11 dB. Insertion loss > 11 dB.	0x3	R/W
		[1:0]	EQ_GAIN_PHY0	01 11	Equalizer gain for PHY 0 based on insertion loss of the system. Insertion loss ≤ 11 dB. Insertion loss > 11 dB.	0x3	R/W
0x243	EQ_GAIN_PHY_7_4	[7:6]	EQ_GAIN_PHY7	01 11	Equalizer gain for PHY 7 based on insertion loss of the system. Insertion loss ≤ 11 dB. Insertion loss > 11 dB.	0x3	R/W
		[5:4]	EQ_GAIN_PHY6	01 11	Equalizer gain for PHY 6 based on insertion loss of the system. Insertion loss ≤ 11 dB. Insertion loss > 11 dB.	0x3	R/W
		[3:2]	EQ_GAIN_PHY5	01 11	Equalizer gain for PHY 5 based on insertion loss of the system. Insertion loss ≤ 11 dB. Insertion loss > 11 dB.	0x3	R/W
		[1:0]	EQ_GAIN_PHY4	01 11	Equalizer gain for PHY 4 based on insertion loss of the system. Insertion loss ≤ 11 dB. Insertion loss > 11 dB.	0x3	R/W
0x244	EQ_FB_PHY_0	[7:5]	RESERVED		Reserved.	0x0	R
		[4:0]	EQ_PHY_0		SERDES equalizer setting for PHY0. Set this control to 0x1F for optimal performance.	0x19	R/W
0x245	EQ_FB_PHY_1	[7:5]	RESERVED		Reserved.	0x0	R
		[4:0]	EQ_PHY1		SERDES equalizer setting for PHY1. Set this control to 0x1F for optimal performance.	0x19	R/W

Addr.	Name	Bits	Bit Name	Settings	Description	Reset	Access
0x246	EQ_FB_PHY_2	[7:5]	RESERVED		Reserved.	0x0	R
		[4:0]	EQ_PHY2		SERDES equalizer setting for PHY2. Set this control to 0x1F for optimal performance.	0x19	R/W
0x247	EQ_FB_PHY_3	[7:5]	RESERVED		Reserved.	0x0	R
		[4:0]	EQ_PHY3		SERDES equalizer setting for PHY3. Set this control to 0x1F for optimal performance.	0x19	R/W
0x248	EQ_FB_PHY_4	[7:5]	RESERVED		Reserved.	0x0	R
		[4:0]	EQ_PHY4		SERDES equalizer setting for PHY4. Set this control to 0x1F for optimal performance.	0x19	R/W
0x249	EQ_FB_PHY_5	[7:5]	RESERVED		Reserved.	0x0	R
		[4:0]	EQ_PHY5		SERDES equalizer setting for PHY5. Set this control to 0x1F for optimal performance.	0x19	R/W
0x24A	EQ_FB_PHY_6	[7:5]	RESERVED		Reserved.	0x0	R
		[4:0]	EQ_PHY6		SERDES equalizer setting for PHY6. Set this control to 0x1F for optimal performance.	0x19	R/W
0x24B	EQ_FB_PHY_7	[7:5]	RESERVED		Reserved.	0x0	R
		[4:0]	EQ_PHY7		SERDES equalizer setting for PHY7. Set this control to 0x1F for optimal performance.	0x19	R/W
0x250	LBT_REG_CNTRL_0	[7:0]	EN_LBT_DES_RC_CH		Enable loopback test for desired physical lanes per PHY, with Bit x corresponding to PHY x.	0x0	R/W
0x251	LBT_REG_CNTRL_1	[7:2]	RESERVED		Reserved.	0x0	R
		1	EN_LBT_HALFRATE_DES_RC		Enables half rate mode for the loopback test. If this bit is set to 1, the output data rate = 2× the input clock frequency. If this bit is set to 0, the output data rate = the input clock frequency.	0x1	R/W
		0	INIT_LBT_SYNC_DES_RC		Initiate the loopback test by toggling this bit from 0 to 1, then back to 0.	0x0	R/W
0x253	SYNCOUT0_CTRL	[7:1]	RESERVED		Reserved.	0x0	R/W
		0	SEL_SYNCOUT0_MODE	0 1	This control determines the output driver mode for the SYNCOUT0± pin operation. Both SYNCOUT0± and SYNCOUT1± must be set to the same mode of operation. SYNCOUT0± is set to CMOS output. SYNCOUT0± is set to LVDS output.	0x0	R/W
0x254	SYNCOUT1_CTRL	[7:1]	RESERVED		Reserved.	0x0	R/W
		0	SEL_SYNCOUT1_MODE	0 1	This control determines the output driver mode for the SYNCOUT1± pin operation. Both SYNCOUT0± and SYNCOUT1± must be set to the same mode of operation. SYNCOUT1± is set to CMOS output. SYNCOUT1± is set to LVDS output.	0x0	R/W

Addr.	Name	Bits	Bit Name	Settings	Description	Reset	Access
0x280	PLL_ENABLE_CTRL	[7:3]	RESERVED		Reserved.	0x0	R
		2	LOLSTICKYCLEAR_LCPLL_RC		Clears out loss of lock bit.	0x0	R/W
		1	LDSYNTH_LCPLL_RC		Pulse high to start VCO calibration (without restarting the regulator or remeasuring the temperature).	0x0	R/W
		0	SERDES_PLL_STARTUP		SERDES circuitry blocks are powered off when this bit is set to 0. Set this bit to 1 at the end of the SERDES configuration writes. When this bit is set to 1, it powers up the SERDES PLL blocks and starts the LDO and calibration routine to lock the PLL automatically to the appropriate lane rate based on the JESD204B mode and interpolation options programmed in the device. The SERDES_PLL_LOCK bit (Register 0x281, Bit 0) reads 1 when the PLL achieves lock.	0x1	R/W
0x281	PLL_STATUS	[7:1]	RESERVED		Reserved.	0x0	R
		0	SERDES_PLL_LOCK		PLL is locked when this bit is high.	0x0	R
0x300	GENERAL_JRX_CTRL_0	[7:4]	RESERVED		Reserved.	0x0	R
		3	LINK_MODE		Reads back 0 when in single-link mode and 1 when in dual-link mode.	0x0	R/W
		2	LINK_PAGE	0 1	Link paging. This bit selects which link register map is used. This paging affects Register 0x400 to Register 0x4BB. Page QBD0 for Link 0. Page QBD1 for Link 1.	0x0	R/W
		[1:0]	LINK_EN		These bits bring up the JESD204B digital receiver when all link parameters are programmed and all clocks are ready. Bit 0 applies to Link 0, whereas Bit 1 applies to Link 1. Link 1 is only available in dual-link mode.	0x0	R/W
0x302	DYN_LINK_LATENCY_0	[7:6]	RESERVED		Reserved.	0x0	R
		[5:0]	DYN_LINK_LATENCY_0		Dynamic link latency, Link 0. Latency between the LMFC receiver for Link 0 and the last arriving LMFC boundary in units of PCLK cycles.	0x0	R
0x303	DYN_LINK_LATENCY_1	[7:6]	RESERVED		Reserved.	0x0	R
		[5:0]	DYN_LINK_LATENCY_1		Dynamic link latency, Link 1. Latency between the LMFC receiver for Link 1 and the last arriving LMFC boundary in units of PCLK cycles.	0x0	R
0x304	LMFC_DELAY_0	[7:6]	RESERVED		Reserved.	0x0	R
		[5:0]	LMFC_DELAY_0		LMFC delay, Link 0. Delay from the LMFC to the LMFC receiver for Link 0 in units of PCLK cycles.	0x0	R/W
0x305	LMFC_DELAY_1	[7:6]	RESERVED		Reserved.	0x0	R
		[5:0]	LMFC_DELAY_1		LMFC delay, Link 1. Delay from the LMFC to the LMFC receiver for Link 1 in units of PCLK cycles.	0x0	R/W
0x306	LMFC_VAR_0	[7:6]	RESERVED		Reserved.	0x0	R
		[5:0]	LMFC_VAR_0		Variable delay buffer, Link 0. These bits set when data is read from a buffer to be consistent across links and power cycles (in units of PCLK cycles). The maximum value is 0xC.	0x3F	R/W

Addr.	Name	Bits	Bit Name	Settings	Description	Reset	Access
0x307	LMFC_VAR_1	[7:6]	RESERVED		Reserved.	0x0	R
		[5:0]	LMFC_VAR_1		Variable delay buffer, Link 1. These bits set when data is read from a buffer to be consistent across links and power cycles (in units of PCLK cycles). The maximum value is 0xC.	0x3F	R/W
0x308	XBAR_LN_0_1	[7:6]	RESERVED		Reserved.	0x0	R
		[5:3]	LOGICAL_LANE1_SRC		Logical Lane 1 source. These bits select a physical lane to be mapped onto Logical Lane 1.	0x1	R/W
				000	Data is from SERDIN0±.		
				001	Data is from SERDIN1±.		
010	Data is from SERDIN2±.						
011	Data is from SERDIN3±.						
100	Data is from SERDIN4±.						
101	Data is from SERDIN5±.						
110	Data is from SERDIN6±.						
111	Data is from SERDIN7±.						
[2:0]	LOGICAL_LANE0_SRC		Logical Lane 0 source. These bits select a physical lane to be mapped onto Logical Lane 0.	0x0	R/W		
		000	Data is from SERDIN0±.				
		001	Data is from SERDIN1±.				
		010	Data is from SERDIN2±.				
		011	Data is from SERDIN3±.				
		100	Data is from SERDIN4±.				
		101	Data is from SERDIN5±.				
		110	Data is from SERDIN6±.				
		111	Data is from SERDIN7±.				
0x309	XBAR_LN_2_3	[7:6]	RESERVED		Reserved.	0x0	R
		[5:3]	LOGICAL_LANE3_SRC		Logical Lane 3 source. These bits select a physical lane to be mapped onto Logical Lane 3.	0x3	R/W
				000	Data is from SERDIN0±.		
				001	Data is from SERDIN1±.		
010	Data is from SERDIN2±.						
011	Data is from SERDIN3±.						
100	Data is from SERDIN4±.						
101	Data is from SERDIN5±.						
110	Data is from SERDIN6±.						
111	Data is from SERDIN7±.						
[2:0]	LOGICAL_LANE2_SRC		Logical Lane 2 source. These bits select a physical lane to be mapped onto Logical Lane 2.	0x2	R/W		
		000	Data is from SERDIN0±.				
		001	Data is from SERDIN1±.				
		010	Data is from SERDIN2±.				
		011	Data is from SERDIN3±.				
		100	Data is from SERDIN4±.				
		101	Data is from SERDIN5±.				
		110	Data is from SERDIN6±.				
		111	Data is from SERDIN7±.				

Addr.	Name	Bits	Bit Name	Settings	Description	Reset	Access
0x30A	XBAR_LN_4_5	[7:6]	RESERVED		Reserved.	0x0	R
		[5:3]	LOGICAL_LANES5_SRC		Logical Lane 5 source. These bits select a physical lane to be mapped onto Logical Lane 5.	0x5	R/W
				000	Data is from SERDIN0±.		
				001	Data is from SERDIN1±.		
				010	Data is from SERDIN2±.		
				011	Data is from SERDIN3±.		
100	Data is from SERDIN4±.						
101	Data is from SERDIN5±.						
110	Data is from SERDIN6±.						
111	Data is from SERDIN7±.						
		[2:0]	LOGICAL_LANE4_SRC		Logical Lane 4 source. These bits select a physical lane to be mapped onto Logical Lane 4.	0x4	R/W
				000	Data is from SERDIN0±.		
				001	Data is from SERDIN1±.		
				010	Data is from SERDIN2±.		
				011	Data is from SERDIN3±.		
				100	Data is from SERDIN4±.		
				101	Data is from SERDIN5±.		
				110	Data is from SERDIN6±.		
				111	Data is from SERDIN7±.		
0x30B	XBAR_LN_6_7	[7:6]	RESERVED		Reserved.	0x0	R
		[5:3]	LOGICAL_LANE7_SRC		Logical Lane 7 source. These bits select a physical lane to be mapped onto Logical Lane 7.	0x7	R/W
				000	Data is from SERDIN0±.		
				001	Data is from SERDIN1±.		
				010	Data is from SERDIN2±.		
				011	Data is from SERDIN3±.		
100	Data is from SERDIN4±.						
101	Data is from SERDIN5±.						
110	Data is from SERDIN6±.						
111	Data is from SERDIN7±.						
		[2:0]	LOGICAL_LANE6_SRC		Logical Lane 6 source. These bits select a physical lane to be mapped onto Logical Lane 6.	0x6	R/W
				000	Data is from SERDIN0±.		
				001	Data is from SERDIN1±.		
				010	Data is from SERDIN2±.		
				011	Data is from SERDIN3±.		
				100	Data is from SERDIN4±.		
				101	Data is from SERDIN5±.		
				110	Data is from SERDIN6±.		
				111	Data is from SERDIN7±.		
0x30C	FIFO_STATUS_REG_0	[7:0]	LANE_FIFO_FULL		Bit x corresponds to FIFO full flag for data from SERDINx±.	0x0	R
0x30D	FIFO_STATUS_REG_1	[7:0]	LANE_FIFO_EMPTY		Bit x corresponds to FIFO empty flag for data from SERDINx±.	0x0	R

Addr.	Name	Bits	Bit Name	Settings	Description	Reset	Access
0x311	SYNCOUT_GEN_0	[7:4]	RESERVED		Reserved.	0x0	R
		3	EOMF_MASK_1	0	Mask end of multiframe (EOMF) from QBD1. Assert $\overline{\text{SYNCOUT1}}_{\pm}$ based on the loss of the multiframe synchronization. Do not assert $\overline{\text{SYNCOUT1}}_{\pm}$ on loss of multiframe.	0x0	R/W
				1	Assert $\overline{\text{SYNCOUT1}}_{\pm}$ on loss of multiframe.		
		2	EOMF_MASK_0	0	Mask EOMF from QBD0. Assert $\overline{\text{SYNCOUT0}}_{\pm}$ based on the loss of the multiframe synchronization. Do not assert $\overline{\text{SYNCOUT0}}_{\pm}$ on loss of multiframe.	0x0	R/W
				1	Assert $\overline{\text{SYNCOUT0}}_{\pm}$ on loss of multiframe.		
1	EOF_MASK_1	0	Mask EOF from QBD1. Assert $\overline{\text{SYNCOUT1}}_{\pm}$ based on loss of frame synchronization. Do not assert $\overline{\text{SYNCOUT1}}_{\pm}$ on loss of frame.	0x0	R/W		
		1	Assert $\overline{\text{SYNCOUT1}}_{\pm}$ on loss of frame.				
0	EOF_MASK_0	0	Mask EOF from QBD0. Assert $\overline{\text{SYNCOUT0}}_{\pm}$ based on loss of frame synchronization. Do not assert $\overline{\text{SYNCOUT0}}_{\pm}$ on loss of frame.	0x0	R/W		
		1	Assert $\overline{\text{SYNCOUT0}}_{\pm}$ on loss of frame.				
0x312	SYNCOUT_GEN_1	[7:4]	SYNC_ERR_DUR		Duration of $\overline{\text{SYNCOUTx}}_{\pm}$ low for the purposes of the synchronization error report. Duration = (0.5 + code) PCLK cycles. To most closely match the specified value, set these bits as close as possible to f/2 PCLK cycles. These bits are shared between $\overline{\text{SYNCOUT0}}_{\pm}$ and $\overline{\text{SYNCOUT1}}_{\pm}$ .	0x0	R/W
		[3:0]	RESERVED		Reserved.	0x0	R/W
0x315	PHY_PRBS_TEST_EN	[7:0]	PHY_TEST_EN	0 1	Enable PHY BER by ungating the clocks. PHY test disable. PHY test enable.	0x0	R/W
0x316	PHY_PRBS_TEST_CTRL	7	RESERVED		Reserved.	0x0	R
		[6:4]	PHY_SRC_ERR_CNT	000	Report Lane 0 error count.	0x0	R/W
				001	Report Lane 1 error count.		
				010	Report Lane 2 error count.		
011	Report Lane 3 error count.						
100	Report Lane 4 error count.						
101	Report Lane 5 error count.						
110	Report Lane 6 error count.						
111	Report Lane 7 error count.						
[3:2]	PHY_PRBS_PAT_SEL	00	Select PRBS pattern for PHY BER test. PRBS7.	0x0	R/W		
		01	PRBS15.				
		10	PRBS31.				
		11	Not used.				
1	PHY_TEST_START	0	Starts and stops the PHY PRBS test. Test not started.	0x0	R/W		
		1	Test started.				

Addr.	Name	Bits	Bit Name	Settings	Description	Reset	Access
		0	PHY_TEST_RESET	0 1	Resets PHY PRBS test state machine and error counters. Not reset. Reset.	0x0	R/W
0x317	PHY_PRBS_TEST_THRESHOLD_LOBITS	[7:0]	PHY_PRBS_THRESHOLD_LOBITS		Bits[7:0] of the 24-bit threshold value to set the error flag for the PHY PRBS test.	0x0	R/W
0x318	PHY_PRBS_TEST_THRESHOLD_MIDBITS	[7:0]	PHY_PRBS_THRESHOLD_MIDBITS		Bits[15:8] of the 24-bit threshold value to set the error flag for the PHY PRBS test.	0x0	R/W
0x319	PHY_PRBS_TEST_THRESHOLD_HIBITS	[7:0]	PHY_PRBS_THRESHOLD_HIBITS		Bits[23:16] of the 24-bit threshold value to set the error flag for the PHY PRBS test.	0x0	R/W
0x31A	PHY_PRBS_TEST_ERRCNT_LOBITS	[7:0]	PHY_PRBS_ERRCNT_LOBITS		Bits[7:0] of the 24-bit reported PHY BER error count from the selected lane.	0x0	R
0x31B	PHY_PRBS_TEST_ERRCNT_MIDBITS	[7:0]	PHY_PRBS_ERRCNT_MIDBITS		Bits[15:8] of the 24-bit reported PHY BER error count from the selected lane.	0x0	R
0x31C	PHY_PRBS_TEST_ERRCNT_HIBITS	[7:0]	PHY_PRBS_ERRCNT_HIBITS		Bits[23:16] of the 24-bit reported PHY BER error count from the selected lane.	0x0	R
0x31D	PHY_PRBS_TEST_STATUS	[7:0]	PHY_PRBS_PASS		Reports PHY BER pass/fail for each lane. Bit x is high when Lane x passes.	0xFF	R
0x31E	PHY_DATA_SNAPSHOT_CTRL	[7:2]	RESERVED		Reserved.	0x0	R
		1	PHY_GRAB_MODE	0 1	This bit determines whether to use the trigger to grab data. Grab data when PHY_GRAB_DATA is set. Grab data upon bit error.	0x0	R/W
		0	PHY_GRAB_DATA		Transitioning this bit from 0 to 1 causes the logic to store current receive data from one lane.	0x0	R/W
0x31F	PHY_SNAPSHOT_DATA_BYTE0	[7:0]	PHY_SNAPSHOT_DATA_BYTE0		Current data received. Represents PHY_SNAPSHOT_DATA[7:0].	0x0	R
0x320	PHY_SNAPSHOT_DATA_BYTE1	[7:0]	PHY_SNAPSHOT_DATA_BYTE1		Current data received. Represents PHY_SNAPSHOT_DATA[15:8].	0x0	R
0x321	PHY_SNAPSHOT_DATA_BYTE2	[7:0]	PHY_SNAPSHOT_DATA_BYTE2		Current data received. Represents PHY_SNAPSHOT_DATA[23:16].	0x0	R
0x322	PHY_SNAPSHOT_DATA_BYTE3	[7:0]	PHY_SNAPSHOT_DATA_BYTE3		Current data received. Represents PHY_SNAPSHOT_DATA[31:24].	0x0	R
0x323	PHY_SNAPSHOT_DATA_BYTE4	[7:0]	PHY_SNAPSHOT_DATA_BYTE4		Current data received. Represents PHY_SNAPSHOT_DATA[39:32].	0x0	R

Addr.	Name	Bits	Bit Name	Settings	Description	Reset	Access
0x32C	SHORT_TPL_TEST_0	[7:4]	SHORT_TPL_SP_SEL		Short transport layer sample select. Selects which sample to check from a specific DAC.	0x0	R/W
				0000	Sample 0.		
				0001	Sample 1.		
				0010	Sample 2.		
				0011	Sample 3.		
				0100	Sample 4.		
				0101	Sample 5.		
				0110	Sample 6.		
				0111	Sample 7.		
				1000	Sample 8.		
				1001	Sample 9.		
				1010	Sample 10.		
				1011	Sample 11.		
				1100	Sample 12.		
				1101	Sample 13.		
				1110	Sample 14.		
				1111	Sample 15.		
0x32D	SHORT_TPL_TEST_0	[3:2]	SHORT_TPL_CHAN_SEL		Short transport layer test channel select. Selects which subchannel of the DACx channelizer to test.	0x0	R/W
				00	Channel 0.		
				01	Channel 1.		
				10	Channel 2.		
0x32D	SHORT_TPL_TEST_1	1	SHORT_TPL_TEST_RESET		Short transport layer test reset. Resets the result of short transport layer test.	0x0	R/W
				0	Not reset.		
				1	Reset.		
0x32D	SHORT_TPL_TEST_2	0	SHORT_TPL_TEST_EN		Short transport layer test enable. Enable short transport layer test.	0x0	R/W
				0	Disable.		
				1	Enable.		
0x32D	SHORT_TPL_TEST_1	[7:0]	SHORT_TPL_REF_SP_LSB		Short transport layer reference sample, LSB. This bit field is the lower eight bits of the expected DAC sample during the short transport layer test and is used to compare with the received sample at the JESD204B receiver output.	0x0	R/W
0x32E	SHORT_TPL_TEST_2	[7:0]	SHORT_TPL_REF_SP_MSB		Short transport layer test reference sample, MSB. This bit field is the upper eight bits of the expected DAC sample during the short transport layer test and is used to compare with the received sample at the JESD204B receiver output.	0x0	R/W

Addr.	Name	Bits	Bit Name	Settings	Description	Reset	Access
0x32F	SHORT_TPL_TEST_3	7	SHORT_TPL_LINK_SEL	0 1	For running STPL on dual-link JESD204B modes. Selects whether the STPL test is performed on samples that are addressed to the DAC0 channelizers/datapaths (Link 0), or the DAC1 channelizers/datapaths (Link 1). Link 0 samples are tested. Link 1 samples are tested.	0x0	R/W
		6	SHORT_TPL_IQ_SAMPLE_SEL	0 1	Selects which data stream (path) to test for a complex subchannel of the channelizer, I or Q. For nonIQ JESD204B modes, select the I path. Select to test the I data stream. Select to test the Q data stream.	0x0	R/W
		[5:1]	RESERVED		Reserved.	0x0	R/W
		0	SHORT_TPL_FAIL	0 1	Short transport layer test fail. This bit shows if the selected DAC sample matches the expected sample for the short transport layer test. If they match, the test passes. Otherwise, the test fails. Test pass. Test fail.	0x0	R
0x334	JESD_BIT_INVERSE_CTRL	[7:0]	JESD_BIT_INVERSE		Logical lane invert. Each bit of this control inverts the JESD204B deserialized data from one specific JESD204B receiver PHY. Set Bit x high to invert the JESD204B deserialized data on Logical Lane x.	0x0	R/W
0x400	DID_REG	[7:0]	DID_RD		Received ILAS configuration on Lane 0. This control is paged by the LINK_PAGE control in Register 0x300.	0x0	R
0x401	BID_REG	[7:0]	BID_RD		Received ILAS configuration on Lane 0. This control is paged by the LINK_PAGE control in Register 0x300.	0x0	R
0x402	LIDO_REG	7	RESERVED		Reserved.	0x0	R
		6	ADJDIR_RD		Received ILAS configuration on Lane 0. This control is paged by the LINK_PAGE control in Register 0x300.	0x0	R
		5	PHADJ_RD		Received ILAS configuration on Lane 0. This control is paged by the LINK_PAGE control in Register 0x300.	0x0	R
		[4:0]	LL_LID0		Received ILAS LID configuration on Lane 0. This control is paged by the LINK_PAGE control in Register 0x300.	0x0	R
0x403	SCR_L_REG	7	SCR_RD	0 1	Received ILAS configuration on Lane 0. This control is paged by the LINK_PAGE control in Register 0x300. Scrambling is disabled. Scrambling is enabled.	0x0	R
		[6:5]	RESERVED		Reserved.	0x0	R
		[4:0]	L_RD_1	00000 00001 00010 00011	Received ILAS configuration on Lane 0. This control is paged by the LINK_PAGE control in Register 0x300. 1 lane per converter device. 2 lanes per converter device. 3 lanes per converter device. 4 lanes per converter device.	0x0	R

Addr.	Name	Bits	Bit Name	Settings	Description	Reset	Access
0x404	F_REG	[7:0]	F_RD_1	0 1 10 11	Received ILAS configuration on Lane 0. This control is paged by the LINK_PAGE control in Register 0x300. 1 octet per frame. 2 octets per frame. 3 octets per frame. 4 octets per frame.	0x0	R
0x405	K_REG	[7:5]	RESERVED		Reserved.	0x0	R
		[4:0]	K_RD_1	00000 11111	Received ILAS configuration on Lane 0. This control is paged by the LINK_PAGE control in Register 0x300. Default value. 32 frames per multiframe.	0x0	R
0x406	M_REG	[7:0]	M_RD_1		Received ILAS configuration on Lane 0. This control is paged by the LINK_PAGE control in Register 0x300.	0x0	R
0x407	CS_N_REG	[7:6]	CS_RD		Received ILAS configuration on Lane 0. This control is paged by the LINK_PAGE control in Register 0x300.	0x0	R
		5	RESERVED		Reserved.	0x0	R
		[4:0]	N_RD_1		Received ILAS configuration on Lane 0. This control is paged by the LINK_PAGE control in Register 0x300.	0x0	R
0x408	NP_REG	[7:5]	SUBCLASSV_RD		Received ILAS configuration on Lane 0. This control is paged by the LINK_PAGE control in Register 0x300.	0x0	R
		[4:0]	NP_RD_1		Received ILAS configuration on Lane 0. This control is paged by the LINK_PAGE control in Register 0x300.	0x0	R
0x409	S_REG	[7:5]	JESDV_RD_1	000 001	Received ILAS configuration on Lane 0. This control is paged by the LINK_PAGE control in Register 0x300. JESD204A. JESD204B.	0x0	R
		[4:0]	S_RD_1		Received ILAS configuration on Lane 0. This control is paged by the LINK_PAGE control in Register 0x300.	0x0	R
0x40A	HD_CF_REG	7	HD_RD	0 1	Received ILAS configuration on Lane 0. This control is paged by the LINK_PAGE control in Register 0x300. Low density mode. High density mode.	0x0	R
		[6:5]	RESERVED		Reserved.	0x0	R
		[4:0]	CF_RD		Received ILAS configuration on Lane 0. This control is paged by the LINK_PAGE control in Register 0x300.	0x0	R
0x40B	RES1_REG	[7:0]	RES1_RD		Received ILAS configuration on Lane 0. This control is paged by the LINK_PAGE control in Register 0x300.	0x0	R
0x40C	RES2_REG	[7:0]	RES2_RD		Received ILAS configuration on Lane 0. This control is paged by the LINK_PAGE control in Register 0x300.	0x0	R
0x40D	CHECKSUM0_REG	[7:0]	LL_FCHKO		Received checksum during ILAS on Lane 0. This control is paged by the LINK_PAGE control in Register 0x300.	0x0	R

Addr.	Name	Bits	Bit Name	Settings	Description	Reset	Access
0x40E	COMPSUM0_REG	[7:0]	LL_FCMP0		Computed checksum on Lane 0. This control is paged by the LINK_PAGE control in Register 0x300.	0x0	R
0x412	LID1_REG	[7:5]	RESERVED		Reserved.	0x0	R
		[4:0]	LL_LID1		Received ILAS LID configuration on Lane 1. This control is paged by the LINK_PAGE control in Register 0x300.	0x0	R
0x415	CHECKSUM1_REG	[7:0]	LL_FCHK1		Received checksum during ILAS on Lane 1. This control is paged by the LINK_PAGE control in Register 0x300.	0x0	R
0x416	COMPSUM1_REG	[7:0]	LL_FCMP1		Computed checksum on Lane 1. This control is paged by the LINK_PAGE control in Register 0x300.	0x0	R
0x41A	LID2_REG	[7:5]	RESERVED		Reserved.	0x0	R
		[4:0]	LL_LID2		Received ILAS LID configuration on Lane 2. This control is paged by the LINK_PAGE control in Register 0x300.	0x0	R
0x41D	CHECKSUM2_REG	[7:0]	LL_FCHK2		Received checksum during ILAS on Lane 2. This control is paged by the LINK_PAGE control in Register 0x300.	0x0	R
0x41E	COMPSUM2_REG	[7:0]	LL_FCMP2		Computed checksum on Lane 2. This control is paged by the LINK_PAGE control in Register 0x300.	0x0	R
0x422	LID3_REG	[7:5]	RESERVED		Reserved.	0x0	R
		[4:0]	LL_LID3		Received ILAS LID configuration on Lane 3. This control is paged by the LINK_PAGE control in Register 0x300.	0x0	R
0x425	CHECKSUM3_REG	[7:0]	LL_FCHK3		Received checksum during ILAS on Lane 3. This control is paged by the LINK_PAGE control in Register 0x300.	0x0	R
0x426	COMPSUM3_REG	[7:0]	LL_FCMP3		Computed checksum on Lane 3. This control is paged by the LINK_PAGE control in Register 0x300.	0x0	R
0x42A	LID4_REG	[7:5]	RESERVED		Reserved.	0x0	R
		[4:0]	LL_LID4		Received ILAS LID configuration on Lane 4. This control is paged by the LINK_PAGE control in Register 0x300.	0x0	R
0x42D	CHECKSUM4_REG	[7:0]	LL_FCHK4		Received checksum during ILAS on Lane 4. This control is paged by the LINK_PAGE control in Register 0x300.	0x0	R
0x42E	COMPSUM4_REG	[7:0]	LL_FCMP4		Computed checksum on Lane 4. This control is paged by the LINK_PAGE control in Register 0x300.	0x0	R
0x432	LID5_REG	[7:5]	RESERVED		Reserved.	0x0	R
		[4:0]	LL_LID5		Received ILAS LID configuration on Lane 5. This control is paged by the LINK_PAGE control in Register 0x300.	0x0	R
0x435	CHECKSUM5_REG	[7:0]	LL_FCHK5		Received checksum during ILAS on Lane 5. This control is paged by the LINK_PAGE control in Register 0x300.	0x0	R
0x436	COMPSUM5_REG	[7:0]	LL_FCMP5		Computed checksum on Lane 5. This control is paged by the LINK_PAGE control in Register 0x300.	0x0	R
0x43A	LID6_REG	[7:5]	RESERVED		Reserved.	0x0	R
		[4:0]	LL_LID6		Received ILAS LID configuration on Lane 6. This control is paged by the LINK_PAGE control in Register 0x300.	0x0	R

Addr.	Name	Bits	Bit Name	Settings	Description	Reset	Access
0x43D	CHECKSUM6_REG	[7:0]	LL_FCHK6		Received checksum during ILAS on Lane 6. This control is paged by the LINK_PAGE control in Register 0x300.	0x0	R
0x43E	COMPSUM6_REG	[7:0]	LL_FCMP6		Computed checksum on Lane 6. This control is paged by the LINK_PAGE control in Register 0x300.	0x0	R
0x442	LID7_REG	[7:5]	RESERVED		Reserved.	0x0	R
		[4:0]	LL_LID7		Received ILAS LID configuration on Lane 7. This control is paged by the LINK_PAGE control in Register 0x300.	0x0	R
0x445	CHECKSUM7_REG	[7:0]	LL_FCHK7		Received checksum during ILAS on Lane 7. This control is paged by the LINK_PAGE control in Register 0x300.	0x0	R
0x446	COMPSUM7_REG	[7:0]	LL_FCMP7		Computed checksum on Lane 7. This control is paged by the LINK_PAGE control in Register 0x300.	0x0	R
0x450	ILS_DID	[7:0]	DID		Device (link) identification number. This control is paged by the LINK_PAGE control in Register 0x300.	0x0	R/W
0x451	ILS_BID	[7:0]	BID		Bank ID, extension to DID. This control is paged by the LINK_PAGE control in Register 0x300. This signal must only be programmed while the QBD is held in soft reset (Register 0x475, Bit 3), and must not be changed during normal operation.	0x0	R/W
0x452	ILS_LID0	7	RESERVED		Reserved.	0x0	R
		6	ADJDIR		Direction to adjust the DAC LMFC. Link information is received on Link Lane 0 as specified in Section 8.3 of JESD204B. Only Link 0 is supported. This control is paged by the LINK_PAGE control in Register 0x300.	0x0	R/W
		5	PHADJ		Phase adjustment request to the DAC. Only Link 0 is supported. This control is paged by the LINK_PAGE control in Register 0x300.	0x0	R/W
		[4:0]	LID0		Lane identification number (within link). This control is paged by the LINK_PAGE control in Register 0x300. This signal must only be programmed while the QBD is held in soft reset (Register 0x475, Bit 3), and must not be changed during normal operation.	0x0	R/W
0x453	ILS_SCR_L	7	SCR	0	Scramble enabled for the link. This control is paged by the LINK_PAGE control in Register 0x300. Descrambling is disabled.	0x1	R/W
				1			
		[6:5]	RESERVED		Reserved.	0x0	R
	[4:0]	L_1		Number of lanes per converter (minus 1). This control is paged by the LINK_PAGE control in Register 0x300.	0x7	R/W	
0x454	ILS_F	[7:0]	F_1		Number of octets per frame per lane (minus 1). This control is paged by the LINK_PAGE control in Register 0x300.	0x0	R/W
0x455	ILS_K	[7:5]	RESERVED		Reserved.	0x0	R
		[4:0]	K_1	11111	Number of frames per multiframe (minus 1). This control is paged by the LINK_PAGE control in Register 0x300. 32 frames per multiframe.	0x1F	R/W

Addr.	Name	Bits	Bit Name	Settings	Description	Reset	Access
0x456	ILS_M	[7:0]	M_1		Number of subchannels per link (minus 1). This control is paged by the LINK_PAGE control in Register 0x300.	0x1	R/W
0x457	ILS_CS_N	[7:6]	CS		Number of control bits per sample. Only Link 0 is supported. This control is paged by the LINK_PAGE control in Register 0x300.	0x0	R
		5	RESERVED		Reserved.	0x0	R
		[4:0]	N_1		Converter resolution (minus 1). This control is paged by the LINK_PAGE control in Register 0x300.	0xF	R/W
0x458	ILS_NP	[7:5]	SUBCLASSV	000 001	Device subclass version. This control is paged by the LINK_PAGE control in Register 0x300. Subclass 0. Subclass 1.	0x0	R/W
		[4:0]	NP_1		Total number of bits per sample (minus 1). This control is paged by the LINK_PAGE control in Register 0x300.	0xF	R/W
0x459	ILS_S	[7:5]	JESDV	000 001	JESD204 version. This control is paged by the LINK_PAGE control in Register 0x300. JESD204A. JESD204B.	0x0	R/W
		[4:0]	S_1		Number of samples per converter per frame cycle (minus 1). This control is paged by the LINK_PAGE control in Register 0x300.	0x1	R/W
0x45A	ILS_HD_CF	7	HD	0 1	High density format, always set to 1. This control is paged by the LINK_PAGE control in Register 0x300. Low density mode. High density mode.	0x1	R
		[6:5]	RESERVED		Reserved.	0x0	R
		[4:0]	CF		Number of control bits per sample. Only Link 0 is supported. This control is paged by the LINK_PAGE control in Register 0x300.	0x0	R
0x45B	ILS_RES1	[7:0]	RES1		Reserved field 1. This control is paged by the LINK_PAGE control in Register 0x300.	0x0	R/W
0x45C	ILS_RES2	[7:0]	RES2		Reserved field 2. This control is paged by the LINK_PAGE control in Register 0x300.	0x0	R/W
0x45D	ILS_CHECKSUM	[7:0]	FCHK0		Calculated link configuration checksum. This control is paged by the LINK_PAGE control in Register 0x300. This signal must only be programmed while the QBD is held in soft reset (Register 0x475, Bit 3), and must not be changed during normal operation.	0x0	R/W
0x46C	LANE_DESKEW	7	ILD7	0 1	Interlane deskew status for Lane 7. This control is paged by the LINK_PAGE control in Register 0x300. Deskew failed. Deskew achieved.	0x0	R
		6	ILD6	0 1	Interlane deskew status for Lane 6. This control is paged by the LINK_PAGE control in Register 0x300. Deskew failed. Deskew achieved.	0x0	R

Addr.	Name	Bits	Bit Name	Settings	Description	Reset	Access
		5	ILD5	0 1	Interlane deskew status for Lane 5. This control is paged by the LINK_PAGE control in Register 0x300. Deskew failed. Deskew achieved.	0x0	R
		4	ILD4	0 1	Interlane deskew status for Lane 4. This control is paged by the LINK_PAGE control in Register 0x300. Deskew failed. Deskew achieved.	0x0	R
		3	ILD3	0 1	Interlane deskew status for Lane 3. This control is paged by the LINK_PAGE control in Register 0x300. Deskew failed. Deskew achieved.	0x0	R
		2	ILD2	0 1	Interlane deskew status for Lane 2. This control is paged by the LINK_PAGE control in Register 0x300. Deskew failed. Deskew achieved.	0x0	R
		1	ILD1	0 1	Interlane deskew status for Lane 1. This control is paged by the LINK_PAGE control in Register 0x300. Deskew failed. Deskew achieved.	0x0	R
		0	ILD0	0 1	Interlane deskew status for Lane 0. This control is paged by the LINK_PAGE control in Register 0x300. Deskew failed. Deskew achieved.	0x0	R
0x46D	BAD_DISPARITY	7	BDE7	0 1	Bad disparity errors status for Lane 7. This control is paged by the LINK_PAGE control in Register 0x300. Error count < error threshold (ETH)[7:0] value. Error count ≥ ETH[7:0] value.	0x0	R
		6	BDE6	0 1	Bad disparity errors status for Lane 6. This control is paged by the LINK_PAGE control in Register 0x300. Error count < ETH[7:0] value. Error count ≥ ETH[7:0] value.	0x0	R
		5	BDE5	0 1	Bad disparity errors status for Lane 5. This control is paged by the LINK_PAGE control in Register 0x300. Error count < ETH[7:0] value. Error count ≥ ETH[7:0] value.	0x0	R
		4	BDE4	0 1	Bad disparity errors status for Lane 4. This control is paged by the LINK_PAGE control in Register 0x300. Error count < ETH[7:0] value. Error count ≥ ETH[7:0] value.	0x0	R
		3	BDE3	0 1	Bad disparity errors status for Lane 3. This control is paged by the LINK_PAGE control in Register 0x300. Error count < ETH[7:0] value. Error count ≥ ETH[7:0] value.	0x0	R

Addr.	Name	Bits	Bit Name	Settings	Description	Reset	Access
		2	BDE2	0 1	Bad disparity errors status for Lane 2. This control is paged by the LINK_PAGE control in Register 0x300. Error count < ETH[7:0] value. Error count ≥ ETH[7:0] value.	0x0	R
		1	BDE1	0 1	Bad disparity errors status for Lane 1. This control is paged by the LINK_PAGE control in Register 0x300. Error count < ETH[7:0] value. Error count ≥ ETH[7:0] value.	0x0	R
		0	BDE0	0 1	Bad disparity errors status for Lane 0. This control is paged by the LINK_PAGE control in Register 0x300. Error count < ETH[7:0] value. Error count ≥ ETH[7:0] value.	0x0	R
0x46E	NOT_IN_TABLE	7	NIT7	0 1	Not in table errors status for Lane 7. This control is paged by the LINK_PAGE control in Register 0x300. Error count < ETH[7:0] value. Error count ≥ ETH[7:0] value.	0x0	R
		6	NIT6	0 1	Not in table errors status for Lane 6. This control is paged by the LINK_PAGE control in Register 0x300. Error count < ETH[7:0] value. Error count ≥ ETH[7:0] value.	0x0	R
		5	NIT5	0 1	Not in table errors status for Lane 5. This control is paged by the LINK_PAGE control in Register 0x300. Error count < ETH[7:0] value. Error count ≥ ETH[7:0] value.	0x0	R
		4	NIT4	0 1	Not in table errors status for Lane 4. This control is paged by the LINK_PAGE control in Register 0x300. Error count < ETH[7:0] value. Error count ≥ ETH[7:0] value.	0x0	R
		3	NIT3	0 1	Not in table errors status for Lane 3. This control is paged by the LINK_PAGE control in Register 0x300. Error count < ETH[7:0] value. Error count ≥ ETH[7:0] value.	0x0	R
		2	NIT2	0 1	Not in table errors status for Lane 2. This control is paged by the LINK_PAGE control in Register 0x300. Error count < ETH[7:0] value. Error count ≥ ETH[7:0] value.	0x0	R
		1	NIT1	0 1	Not in table errors status for Lane 1. This control is paged by the LINK_PAGE control in Register 0x300. Error count < ETH[7:0] value. Error count ≥ ETH[7:0] value.	0x0	R
		0	NIT0	0 1	Not in table errors status for Lane 0. This control is paged by the LINK_PAGE control in Register 0x300. Error count < ETH[7:0] value. Error count ≥ ETH[7:0] value.	0x0	R

Addr.	Name	Bits	Bit Name	Settings	Description	Reset	Access
0x46F	UNEXPECTED_KCHAR	7	UEK7	0 1	Unexpected K character errors status, Lane 7. This control is paged by the LINK_PAGE control in Register 0x300. Error count < ETH[7:0] value. Error count ≥ ETH[7:0] value.	0x0	R
		6	UEK6	0 1	Unexpected K character errors status, Lane 6. This control is paged by the LINK_PAGE control in Register 0x300. Error count < ETH[7:0] value. Error count ≥ ETH[7:0] value.	0x0	R
		5	UEK5	0 1	Unexpected K character errors status, Lane 5. This control is paged by the LINK_PAGE control in Register 0x300. Error count < ETH[7:0] value. Error count ≥ ETH[7:0] value.	0x0	R
		4	UEK4	0 1	Unexpected K character errors status, Lane 4. This control is paged by the LINK_PAGE control in Register 0x300. Error count < ETH[7:0] value. Error count ≥ ETH[7:0] value.	0x0	R
		3	UEK3	0 1	Unexpected K character errors status, Lane 3. This control is paged by the LINK_PAGE control in Register 0x300. Error count < ETH[7:0] value. Error count ≥ ETH[7:0] value.	0x0	R
		2	UEK2	0 1	Unexpected K character errors status, Lane 2. This control is paged by the LINK_PAGE control in Register 0x300. Error count < ETH[7:0] value. Error count ≥ ETH[7:0] value.	0x0	R
		1	UEK1	0 1	Unexpected K character errors status, Lane 1. This control is paged by the LINK_PAGE control in Register 0x300. Error count < ETH[7:0] value. Error count ≥ ETH[7:0] value.	0x0	R
		0	UEK0	0 1	Unexpected K character errors status, Lane 0. This control is paged by the LINK_PAGE control in Register 0x300. Error count < ETH[7:0] value. Error count ≥ ETH[7:0] value.	0x0	R
0x470	CODE_GRP_SYNC	7	CGS7	0 1	Code group synchronization status for Lane 7. This control is paged by the LINK_PAGE control in Register 0x300. Synchronization lost. Synchronization achieved.	0x0	R
		6	CGS6	0 1	Code group synchronization status for Lane 6. This control is paged by the LINK_PAGE control in Register 0x300. Synchronization lost. Synchronization achieved.	0x0	R
		5	CGS5	0 1	Code group synchronization status for Lane 5. This control is paged by the LINK_PAGE control in Register 0x300. Synchronization lost. Synchronization achieved.	0x0	R

Addr.	Name	Bits	Bit Name	Settings	Description	Reset	Access
		4	CGS4	0 1	Code group synchronization status for Lane 4. This control is paged by the LINK_PAGE control in Register 0x300. Synchronization lost. Synchronization achieved.	0x0	R
		3	CGS3	0 1	Code group synchronization status for Lane 3. This control is paged by the LINK_PAGE control in Register 0x300. Synchronization lost. Synchronization achieved.	0x0	R
		2	CGS2	0 1	Code group synchronization status for Lane 2. This control is paged by the LINK_PAGE control in Register 0x300. Synchronization lost. Synchronization achieved.	0x0	R
		1	CGS1	0 1	Code group synchronization status for Lane 1. This control is paged by the LINK_PAGE control in Register 0x300. Synchronization lost. Synchronization achieved.	0x0	R
		0	CGS0	0 1	Code group synchronization status for Lane 0. This control is paged by the LINK_PAGE control in Register 0x300. Synchronization lost. Synchronization achieved.	0x0	R
0x471	FRAME_SYNC	7	FS7	0 1	Frame synchronization status for Lane 7. This control is paged by the LINK_PAGE control in Register 0x300. Synchronization lost. Synchronization achieved.	0x0	R
		6	FS6	0 1	Frame synchronization status for Lane 6. This control is paged by the LINK_PAGE control in Register 0x300. Synchronization lost. Synchronization achieved.	0x0	R
		5	FS5	0 1	Frame synchronization status for Lane 5. This control is paged by the LINK_PAGE control in Register 0x300. Synchronization lost. Synchronization achieved.	0x0	R
		4	FS4	0 1	Frame synchronization status for Lane 4. This control is paged by the LINK_PAGE control in Register 0x300. Synchronization lost. Synchronization achieved.	0x0	R
		3	FS3	0 1	Frame synchronization status for Lane 3. This control is paged by the LINK_PAGE control in Register 0x300. Synchronization lost. Synchronization achieved.	0x0	R
		2	FS2	0 1	Frame synchronization status for Lane 2. This control is paged by the LINK_PAGE control in Register 0x300. Synchronization lost. Synchronization achieved.	0x0	R

Addr.	Name	Bits	Bit Name	Settings	Description	Reset	Access
		1	FS1	0 1	Frame synchronization status for Lane 1. This control is paged by the LINK_PAGE control in Register 0x300. Synchronization lost. Synchronization achieved.	0x0	R
		0	FS0	0 1	Frame synchronization status for Lane 0. This control is paged by the LINK_PAGE control in Register 0x300. Synchronization lost. Synchronization achieved.	0x0	R
0x472	GOOD_CHECKSUM	7	CKS7	0 1	Computed checksum status for Lane 7. This control is paged by the LINK_PAGE control in Register 0x300. Checksum is incorrect. Checksum is correct.	0x0	R
		6	CKS6	0 1	Computed checksum status for Lane 6. This control is paged by the LINK_PAGE control in Register 0x300. Checksum is incorrect. Checksum is correct.	0x0	R
		5	CKS5	0 1	Computed checksum status for Lane 5. This control is paged by the LINK_PAGE control in Register 0x300. Checksum is incorrect. Checksum is correct.	0x0	R
		4	CKS4	0 1	Computed checksum status for Lane 4. This control is paged by the LINK_PAGE control in Register 0x300. Checksum is incorrect. Checksum is correct.	0x0	R
		3	CKS3	0 1	Computed checksum status for Lane 3. This control is paged by the LINK_PAGE control in Register 0x300. Checksum is incorrect. Checksum is correct.	0x0	R
		2	CKS2	0 1	Computed checksum status for Lane 2. This control is paged by the LINK_PAGE control in Register 0x300. Checksum is incorrect. Checksum is correct.	0x0	R
		1	CKS1	0 1	Computed checksum status for Lane 1. This control is paged by the LINK_PAGE control in Register 0x300. Checksum is incorrect. Checksum is correct.	0x0	R
		0	CKS0	0 1	Computed checksum status for Lane 0. This control is paged by the LINK_PAGE control in Register 0x300. Checksum is incorrect. Checksum is correct.	0x0	R

Addr.	Name	Bits	Bit Name	Settings	Description	Reset	Access
0x473	INIT_LANE_SYNC	7	ILS7	0 1	Initial lane synchronization status for Lane 7. This control is paged by the LINK_PAGE control in Register 0x300. Synchronization lost. Synchronization achieved.	0x0	R
		6	ILS6	0 1	Initial lane synchronization status for Lane 6. This control is paged by the LINK_PAGE control in Register 0x300. Synchronization lost. Synchronization achieved.	0x0	R
		5	ILS5	0 1	Initial lane synchronization status for Lane 5. This control is paged by the LINK_PAGE control in Register 0x300. Synchronization lost. Synchronization achieved.	0x0	R
		4	ILS4	0 1	Initial lane synchronization status for Lane 4. This control is paged by the LINK_PAGE control in Register 0x300. Synchronization lost. Synchronization achieved.	0x0	R
		3	ILS3	0 1	Initial lane synchronization status for Lane 3. This control is paged by the LINK_PAGE control in Register 0x300. Synchronization lost. Synchronization achieved.	0x0	R
		2	ILS2	0 1	Initial lane synchronization status for Lane 2. This control is paged by the LINK_PAGE control in Register 0x300. Synchronization lost. Synchronization achieved.	0x0	R
		1	ILS1	0 1	Initial lane synchronization status for Lane 1. This control is paged by the LINK_PAGE control in Register 0x300. Synchronization lost. Synchronization achieved.	0x0	R
		0	ILS0	0 1	Initial lane synchronization status for Lane 0. This control is paged by the LINK_PAGE control in Register 0x300. Synchronization lost. Synchronization achieved.	0x0	R
0x475	CTRLREG0	[7:4]	RESERVED		Reserved.	0x0	R/W
		3	SOFTRST		QBD soft reset. Active high synchronous reset. Resets all hardware to power-on state. This control is paged by the LINK_PAGE control in Register 0x300.	0x0	R/W
		2	FORCESYNCREQ		Command from application to assert a synchronization request. Active high. This control is paged by the LINK_PAGE control in Register 0x300.	0x0	R/W
		1	RESERVED		Reserved.	0x0	R
		0	REPL_FRM_ENA		When this level input is set, it enables the replacement of frames received in error. This control is paged by the LINK_PAGE control in Register 0x300. This signal must only be programmed while the QBD is held in soft reset (Register 0x475, Bit 3), and must not be changed during normal operation.	0x1	R/W

Addr.	Name	Bits	Bit Name	Settings	Description	Reset	Access
0x476	CTRLREG1	[7:5]	RESERVED		Reserved.	0x0	R
		4	QUAL_RDERR	0 1	Error reporting behavior for concurrent not in table (NIT) and running disparity (RD) errors. This control is paged by the LINK_PAGE control in Register 0x300. Set this bit to 1. This signal must only be programmed while the QBD is held in soft reset (Register 0x475, Bit 3), and must not be changed during normal operation. NIT has no effect on RD error. NIT error masks concurrent with RD error.	0x1	R/W
		[3:1]	RESERVED		Reserved.	0x0	R/W
		0	FCHK_N	0 1	Checksum calculation method. This control is paged by the LINK_PAGE control in Register 0x300. This signal must only be programmed while the QBD is held in soft reset (Register 0x475, Bit 3), and must not be changed during normal operation. Checksum is calculated by summing the individual fields in the link configuration table as defined in Section 8.3, Table 20 of the JESD204B standard. Checksum is calculated by summing the registers containing the packed link configuration fields (sum of Register 0x450 to Register 0x45A, modulo 256).	0x0	R/W
0x477	CTRLREG2	7	ILS_MODE	0 1	Data link layer test mode is enabled when this bit is set to 1. CGS pattern is followed by a perpetual ILAS sequence. This control is paged by the LINK_PAGE control in Register 0x300. This signal must only be programmed while the QBD is held in soft reset (Register 0x475, Bit 3), and must not be changed during normal operation. Normal mode. CGS pattern is followed by a perpetual ILAS sequence.	0x0	R/W
		6	RESERVED		Reserved.	0x0	R/W
		5	REPDATATEST		Repetitive data test enable using the JTSPAT pattern. To enable the test, Bit 7 of this register must = 0. This control is paged by the LINK_PAGE control in Register 0x300. This signal must only be programmed while the QBD is held in soft reset (Register 0x475, Bit 3), and must not be changed during normal operation.	0x0	R/W
		4	QUETESTERR	0 1	Queue test error mode. This control is paged by the LINK_PAGE control in Register 0x300. This signal must only be programmed while the QBD is held in soft reset (Register 0x475, Bit 3), and must not be changed during normal operation. When this bit = 0, simultaneous errors on multiple lanes are reported as one error. Selected when this bit = 1 and when REPDATATEST = 1. Detected errors from all lanes are trapped in a counter and sequentially signaled on SYNCOUT $\pm$ .	0x0	R/W

Addr.	Name	Bits	Bit Name	Settings	Description	Reset	Access
		3	AR_ECNTN		Automatic reset of error counter. The error counter that causes assertion of SYNCOUTx± is automatically reset to 0 when AR_ECNTN = 1. All other counters are unaffected. This control is paged by the LINK_PAGE control in Register 0x300. This signal must only be programmed while the QBD is held in soft reset (Register 0x475, Bit 3), and must not be changed during normal operation.	0x0	R/W
		[2:0]	RESERVED		Reserved.	0x0	R
0x478	KVAL	[7:0]	KSYNC		Number of 4 × K multiframe during ILAS. This control is paged by the LINK_PAGE control in Register 0x300. This signal must only be programmed while the QBD is held in soft reset (Register 0x475, Bit 3), and must not be changed during normal operation.	0x1	R/W
0x47C	ERRORTHRES	[7:0]	ETH		Error counter threshold value. These bits set when a SYNCOUTx± error or IRQx interrupt is sent due to BD, NIT, or UEK errors. This control is paged by the LINK_PAGE control in Register 0x300. This signal must only be programmed while the QBD is held in soft reset (Register 0x475, Bit 3), and must not be changed during normal operation.	0xFF	R/W
0x47D	SYNC_ASSERT_MASK	[7:3]	RESERVED		Reserved.	0x0	R
		[2:0]	SYNC_ASSERT_MASK		SYNCOUTx± assertion enable mask for BD, NIT, and UEK error conditions. This control is paged by the LINK_PAGE control in Register 0x300. Active high, SYNCOUTx± assertion enable mask for BD, NIT, and UEK error conditions, respectively. When an error counter, in any lane, has reached the error threshold count, ETH[7:0], and the corresponding SYNC_ASSERT_MASK bit is set, SYNCOUTx± is asserted. The mask bits are as follows (the bit sequence is reversed with respect to the other error count controls and the error counters): Bit 2 = bad disparity error (BDE). Bit 1 = not in table error (NIT). Bit 0 = unexpected K character error (UEK).	0x7	R/W
0x480	ECNT_CTRL0	[7:6]	RESERVED		Reserved.	0x0	R
		[5:3]	ECNT_ENA0		Error counter enables for Lane 0. This control is paged by the LINK_PAGE control in Register 0x300. Counters of each lane are addressed as follows: Bit 5 = unexpected K character error (UEK). Bit 4 = not in table error (NIT). Bit 3 = bad disparity error (BDE).	0x7	R/W
		[2:0]	ECNT_RST0		Reset error counters for Lane 0. This control is paged by the LINK_PAGE control in Register 0x300. Counters of each lane are addressed as follows: Bit 2 = bad disparity error (BDE). Bit 1 = not in table error (NIT). Bit 0 = unexpected K character error (UEK).	0x7	R/W

Addr.	Name	Bits	Bit Name	Settings	Description	Reset	Access
0x481	ECNT_CTRL1	[7:6]	RESERVED		Reserved.	0x0	R
		[5:3]	ECNT_ENA1		Error counter enables for Lane 1. This control is paged by the LINK_PAGE control in Register 0x300. Counters of each lane are addressed as follows: Bit 5 = unexpected K character error (UEK). Bit 4 = not in table error (NIT). Bit 3 = bad disparity error (BDE).	0x7	R/W
		[2:0]	ECNT_RST1		Reset error counters for Lane 1. This control is paged by the LINK_PAGE control in Register 0x300. Counters of each lane are addressed as follows: Bit 2 = unexpected K character error (UEK). Bit 1 = not in table error (NIT). Bit 0 = bad disparity error (BDE).	0x7	R/W
0x482	ECNT_CTRL2	[7:6]	RESERVED		Reserved.	0x0	R
		[5:3]	ECNT_ENA2		Error counter enables for Lane 2. This control is paged by the LINK_PAGE control in Register 0x300. Counters of each lane are addressed as follows: Bit 5 = unexpected K character error (UEK). Bit 4 = not in table error (NIT). Bit 3 = bad disparity error (BDE).	0x7	R/W
		[2:0]	ECNT_RST2		Reset error counters for Lane 2. This control is paged by the LINK_PAGE control in Register 0x300. Counters of each lane are addressed as follows: Bit 2 = unexpected K character error (UEK). Bit 1 = not in table error (NIT). Bit 0 = bad disparity error (BDE).	0x7	R/W
0x483	ECNT_CTRL3	[7:6]	RESERVED		Reserved.	0x0	R
		[5:3]	ECNT_ENA3		Error counter enables for Lane 3. This control is paged by the LINK_PAGE control in Register 0x300. Counters of each lane are addressed as follows: Bit 5 = unexpected K character error (UEK). Bit 4 = not in table error (NIT). Bit 3 = bad disparity error (BDE).	0x7	R/W
		[2:0]	ECNT_RST3		Reset error counters for Lane 3. This control is paged by the LINK_PAGE control in Register 0x300. Counters of each lane are addressed as follows: Bit 2 = unexpected K character error (UEK). Bit 1 = not in table error (NIT). Bit 0 = bad disparity error (BDE).	0x7	R/W

Addr.	Name	Bits	Bit Name	Settings	Description	Reset	Access
0x484	ECNT_CTRL4	[7:6]	RESERVED		Reserved.	0x0	R
		[5:3]	ECNT_ENA4		Error counter enables for Lane 4. This control is paged by the LINK_PAGE control in Register 0x300. Counters of each lane are addressed as follows: Bit 5 = unexpected K character error (UEK). Bit 4 = not in table error (NIT). Bit 3 = bad disparity error (BDE).	0x7	R/W
		[2:0]	ECNT_RST4		Reset error counters for Lane 4. This control is paged by the LINK_PAGE control in Register 0x300. Counters of each lane are addressed as follows: Bit 2 = unexpected K character error (UEK). Bit 1 = not in table error (NIT). Bit 0 = bad disparity error (BDE).	0x7	R/W
0x485	ECNT_CTRL5	[7:6]	RESERVED		Reserved.	0x0	R
		[5:3]	ECNT_ENA5		Error counter enables for Lane 5. This control is paged by the LINK_PAGE control in Register 0x300. Counters of each lane are addressed as follows: Bit 5 = unexpected K character error (UEK). Bit 4 = not in table error (NIT). Bit 3 = bad disparity error (BDE).	0x7	R/W
		[2:0]	ECNT_RST5		Reset error counters for Lane 5. This control is paged by the LINK_PAGE control in Register 0x300. Counters of each lane are addressed as follows: Bit 2 = unexpected K character error (UEK). Bit 1 = not in table error (NIT). Bit 0 = bad disparity error (BDE).	0x7	R/W
0x486	ECNT_CTRL6	[7:6]	RESERVED		Reserved.	0x0	R
		[5:3]	ECNT_ENA6		Error counter enables for Lane 6. This control is paged by the LINK_PAGE control in Register 0x300. Counters of each lane are addressed as follows: Bit 5 = unexpected K character error (UEK). Bit 4 = not in table error (NIT). Bit 3 = bad disparity error (BDE).	0x7	R/W
		[2:0]	ECNT_RST6		Reset error counters for Lane 6. This control is paged by the LINK_PAGE control in Register 0x300. Counters of each lane are addressed as follows: Bit 2 = unexpected K character error (UEK). Bit 1 = not in table error (NIT). Bit 0 = bad disparity error (BDE).	0x7	R/W

Addr.	Name	Bits	Bit Name	Settings	Description	Reset	Access
0x487	ECNT_CTRL7	[7:6]	RESERVED		Reserved.	0x0	R
		[5:3]	ECNT_ENA7		Error counter enables for Lane 7. This control is paged by the LINK_PAGE control in Register 0x300. Counters of each lane are addressed as follows: Bit 5 = unexpected K character error (UEK). Bit 4 = not in table error (NIT). Bit 3 = bad disparity error (BDE).	0x7	R/W
		[2:0]	ECNT_RST7		Reset error counters for Lane 7. This control is paged by the LINK_PAGE control in Register 0x300. Counters of each lane are addressed as follows: Bit 2 = unexpected K character error (UEK). Bit 1 = not in table error (NIT). Bit 0 = bad disparity error (BDE).	0x7	R/W
0x488	ECNT_TCH0	[7:3]	RESERVED		Reserved.	0x0	R
		[2:0]	ECNT_TCH0		Terminal count hold enable of error counters for Lane 0. This control is paged by the LINK_PAGE control in Register 0x300. When set, the designated counter is to hold the terminal count value of 0xFF when it is reached until the counter is reset by the user. Otherwise, the designated counter rolls over. Counters of each lane are addressed as follows: Bit 2 = unexpected K character error (UEK). Bit 1 = not in table error (NIT). Bit 0 = bad disparity error (BDE). This signal must only be programmed while the QBD is held in soft reset (Register 0x475, Bit 3), and must not be changed during normal operation.	0x7	R/W
0x489	ECNT_TCH1	[7:3]	RESERVED		Reserved.	0x0	R
		[2:0]	ECNT_TCH1		Terminal count hold enable of error counters for Lane 1. This control is paged by the LINK_PAGE control in Register 0x300. When set, the designated counter is to hold the terminal count value of 0xFF when it is reached until the counter is reset by the user. Otherwise, the designated counter rolls over. Counters of each lane are addressed as follows: Bit 2 = unexpected K character error (UEK). Bit 1 = not in table error (NIT). Bit 0 = bad disparity error (BDE). This signal must only be programmed while the QBD is held in soft reset (Register 0x475, Bit 3), and must not be changed during normal operation.	0x7	R/W

Addr.	Name	Bits	Bit Name	Settings	Description	Reset	Access
0x48A	ECNT_TCH2	[7:3]	RESERVED		Reserved.	0x0	R
		[2:0]	ECNT_TCH2		Terminal count hold enable of error counters for Lane 2. This control is paged by the LINK_PAGE control in Register 0x300. When set, the designated counter is to hold the terminal count value of 0xFF when it is reached until the counter is reset by the user. Otherwise, the designated counter rolls over. Counters of each lane are addressed as follows: Bit 2 = unexpected K character error (UEK). Bit 1 = not in table error (NIT). Bit 0 = bad disparity error (BDE). This signal must only be programmed while the QBD is held in soft reset (Register 0x475, Bit 3), and must not be changed during normal operation.	0x7	R/W
0x48B	ECNT_TCH3	[7:3]	RESERVED		Reserved.	0x0	R
		[2:0]	ECNT_TCH3		Terminal count hold enable of error counters for Lane 3. This control is paged by the LINK_PAGE control in Register 0x300. When set, the designated counter is to hold the terminal count value of 0xFF when it is reached until the counter is reset by the user. Otherwise, the designated counter rolls over. Counters of each lane are addressed as follows: Bit 2 = unexpected K character error (UEK). Bit 1 = not in table error (NIT). Bit 0 = bad disparity error (BDE). This signal must only be programmed while the QBD is held in soft reset (Register 0x475, Bit 3), and must not be changed during normal operation.	0x7	R/W
0x48C	ECNT_TCH4	[7:3]	RESERVED		Reserved.	0x0	R
		[2:0]	ECNT_TCH4		Terminal count hold enable of error counters for Lane 4. This control is paged by the LINK_PAGE control in Register 0x300. When set, the designated counter is to hold the terminal count value of 0xFF when it is reached until the counter is reset by the user. Otherwise, the designated counter rolls over. Counters of each lane are addressed as follows: Bit 2 = unexpected K character error (UEK). Bit 1 = not in table error (NIT). Bit 0 = bad disparity error (BDE). This signal must only be programmed while the QBD is held in soft reset (Register 0x475, Bit 3), and must not be changed during normal operation.	0x7	R/W

Addr.	Name	Bits	Bit Name	Settings	Description	Reset	Access
0x48D	ECNT_TCH5	[7:3]	RESERVED		Reserved.	0x0	R
		[2:0]	ECNT_TCH5		Terminal count hold enable of error counters for Lane 5. This control is paged by the LINK_PAGE control in Register 0x300. When set, the designated counter is to hold the terminal count value of 0xFF when it is reached until the counter is reset by the user. Otherwise, the designated counter rolls over. Counters of each lane are addressed as follows: Bit 2 = unexpected K character error (UEK). Bit 1 = not in table error (NIT). Bit 0 = bad disparity error (BDE). This signal must only be programmed while the QBD is held in soft reset (Register 0x475, Bit 3), and must not be changed during normal operation.	0x7	R/W
0x48E	ECNT_TCH6	[7:3]	RESERVED		Reserved.	0x0	R
		[2:0]	ECNT_TCH6		Terminal count hold enable of error counters for Lane 6. This control is paged by the LINK_PAGE control in Register 0x300. When set, the designated counter is to hold the terminal count value of 0xFF when it is reached until the counter is reset by the user. Otherwise, the designated counter rolls over. Counters of each lane are addressed as follows: Bit 2 = unexpected K character error (UEK). Bit 1 = not in table error (NIT). Bit 0 = bad disparity error (BDE). This signal must only be programmed while the QBD is held in soft reset (Register 0x475, Bit 3), and must not be changed during normal operation.	0x7	R/W
0x48F	ECNT_TCH7	[7:3]	RESERVED		Reserved.	0x0	R
		[2:0]	ECNT_TCH7		Terminal count hold enable of error counters for Lane 7. This control is paged by the LINK_PAGE control in Register 0x300. When set, the designated counter is to hold the terminal count value of 0xFF when it is reached until the counter is reset by the user. Otherwise, the designated counter rolls over. Counters of each lane are addressed as follows: Bit 2 = unexpected K character error (UEK). Bit 1 = not in table error (NIT). Bit 0 = bad disparity error (BDE). This signal must only be programmed while the QBD is held in soft reset (Register 0x475, Bit 3), and must not be changed during normal operation.	0x7	R/W

Addr.	Name	Bits	Bit Name	Settings	Description	Reset	Access
0x490	ECNT_STAT0	[7:4]	RESERVED		Reserved.	0x0	R
		3	LANE_ENA0		This output indicates if Lane 0 is enabled. This control is paged by the LINK_PAGE control in Register 0x300.	0x0	R
		[2:0]	ECNT_TCR0		Terminal count reached indicator of error counters for Lane 0. This control is paged by the LINK_PAGE control in Register 0x300. Set these bits to 1 when the corresponding counter terminal count value of 0xFF is reached. If ECNT_TCHx is set, the terminal count value for the corresponding counter is held until the counter is reset by the user; otherwise, the counter rolls over and continues counting. Counters of each lane are addressed as follows: Bit 2 = unexpected K character error (UEK). Bit 1 = not in table error (NIT). Bit 0 = bad disparity error (BDE).	0x0	R
0x491	ECNT_STAT1	[7:4]	RESERVED		Reserved.	0x0	R
		3	LANE_ENA1		This output indicates if Lane 1 is enabled. This control is paged by the LINK_PAGE control in Register 0x300.	0x0	R
		[2:0]	ECNT_TCR1		Terminal count reached indicator of error counters for Lane 1. This control is paged by the LINK_PAGE control in Register 0x300. Set these bits to 1 when the corresponding counter terminal count value of 0xFF is reached. If ECNT_TCHx is set, the terminal count value for the corresponding counter is held until the counter is reset by the user; otherwise, the counter rolls over and continues counting. Counters of each lane are addressed as follows: Bit 2 = unexpected K character error (UEK). Bit 1 = not in table error (NIT). Bit 0 = bad disparity error (BDE).	0x0	R
0x492	ECNT_STAT2	[7:4]	RESERVED		Reserved.	0x0	R
		3	LANE_ENA2		This output indicates if Lane 2 is enabled. This control is paged by the LINK_PAGE control in Register 0x300.	0x0	R
		[2:0]	ECNT_TCR2		Terminal count reached indicator of error counters for Lane 2. This control is paged by the LINK_PAGE control in Register 0x300. Set these bits to 1 when the corresponding counter terminal count value of 0xFF is reached. If ECNT_TCHx is set, the terminal count value for the corresponding counter is held until the counter is reset by the user; otherwise, the counter rolls over and continues counting. Counters of each lane are addressed as follows: Bit 2 = unexpected K character error (UEK). Bit 1 = not in table error (NIT). Bit 0 = bad disparity error (BDE).	0x0	R

Addr.	Name	Bits	Bit Name	Settings	Description	Reset	Access
0x493	ECNT_STAT3	[7:4]	RESERVED		Reserved.	0x0	R
		3	LANE_ENA3		This output indicates if Lane 3 is enabled. This control is paged by the LINK_PAGE control in Register 0x300.	0x0	R
		[2:0]	ECNT_TCR3		Terminal count reached indicator of error counters for Lane 3. This control is paged by the LINK_PAGE control in Register 0x300. Set these bits to 1 when the corresponding counter terminal count value of 0xFF is reached. If ECNT_TCHx is set, the terminal count value for the corresponding counter is held until the counter is reset by the user; otherwise, the counter rolls over and continues counting. Counters of each lane are addressed as follows: Bit 2 = unexpected K character error (UEK). Bit 1 = not in table error (NIT). Bit 0 = bad disparity error (BDE).	0x0	R
0x494	ECNT_STAT4	[7:4]	RESERVED		Reserved.	0x0	R
		3	LANE_ENA4		This output indicates if Lane 4 is enabled. This control is paged by the LINK_PAGE control in Register 0x300.	0x0	R
		[2:0]	ECNT_TCR4		Terminal count reached indicator of error counters for Lane 4. This control is paged by the LINK_PAGE control in Register 0x300. Set these bits to 1 when the corresponding counter terminal count value of 0xFF is reached. If ECNT_TCHx is set, the terminal count value for the corresponding counter is held until the counter is reset by the user; otherwise, the counter rolls over and continues counting. Counters of each lane are addressed as follows: Bit 2 = unexpected K character error (UEK). Bit 1 = not in table error (NIT). Bit 0 = bad disparity error (BDE).	0x0	R
0x495	ECNT_STAT5	[7:4]	RESERVED		Reserved.	0x0	R
		3	LANE_ENA5		This output indicates if Lane 5 is enabled. This control is paged by the LINK_PAGE control in Register 0x300.	0x0	R
		[2:0]	ECNT_TCR5		Terminal count reached indicator of error counters for Lane 5. This control is paged by the LINK_PAGE control in Register 0x300. Set these bits to 1 when the corresponding counter terminal count value of 0xFF is reached. If ECNT_TCHx is set, the terminal count value for the corresponding counter is held until the counter is reset by the user; otherwise, the counter rolls over and continues counting. Counters of each lane are addressed as follows: Bit 2 = unexpected K character error (UEK). Bit 1 = not in table error (NIT). Bit 0 = bad disparity error (BDE).	0x0	R

Addr.	Name	Bits	Bit Name	Settings	Description	Reset	Access
0x496	ECNT_STAT6	[7:4]	RESERVED		Reserved.	0x0	R
		3	LANE_ENA6		This output indicates if Lane 6 is enabled. This control is paged by the LINK_PAGE control in Register 0x300.	0x0	R
		[2:0]	ECNT_TCR6		Terminal count reached indicator of error counters for Lane 6. This control is paged by the LINK_PAGE control in Register 0x300. Set these bits to 1 when the corresponding counter terminal count value of 0xFF is reached. If ECNT_TCHx is set, the terminal count value for the corresponding counter is held until the counter is reset by the user; otherwise, the counter rolls over and continues counting. Counters of each lane are addressed as follows: Bit 2 = unexpected K character error (UEK). Bit 1 = not in table error (NIT). Bit 0 = bad disparity error (BDE).	0x0	R
0x497	ECNT_STAT7	[7:4]	RESERVED		Reserved.	0x0	R
		3	LANE_ENA7		This output indicates if Lane 7 is enabled. This control is paged by the LINK_PAGE control in Register 0x300.	0x0	R
		[2:0]	ECNT_TCR7		Terminal count reached indicator of error counters for Lane 7. This control is paged by the LINK_PAGE control in Register 0x300. Set these bits to 1 when the corresponding counter terminal count value of 0xFF is reached. If ECNT_TCHx is set, the terminal count value for the corresponding counter is held until the counter is reset by the user; otherwise, the counter rolls over and continues counting. Counters of each lane are addressed as follows: Bit 2 = unexpected K character error (UEK). Bit 1 = not in table error (NIT). Bit 0 = bad disparity error (BDE).	0x0	R
0x4B0	LINK_STATUS0	7	BDE0	0	Bad disparity errors status for Lane 0. This control is paged by the LINK_PAGE control in Register 0x300.	0x0	R
				1	Error count < ETH[7:0] value. Error count ≥ ETH[7:0] value.		
		6	NIT0	0	Not in table errors status for Lane 0. This control is paged by the LINK_PAGE control in Register 0x300.	0x0	R
				1	Error count < ETH[7:0] value. Error count ≥ ETH[7:0] value.		
5	UEK0	0	Unexpected K character errors status for Lane 0. This control is paged by the LINK_PAGE control in Register 0x300.	0x0	R		
		1	Error count < ETH[7:0] value. Error count ≥ ETH[7:0] value.				
4	ILD0	0	Interlane deskew status for Lane 0. This control is paged by the LINK_PAGE control in Register 0x300.	0x0	R		
		1	Deskew failed. Deskew achieved.				

Addr.	Name	Bits	Bit Name	Settings	Description	Reset	Access
		3	ILS0	0 1	Initial lane synchronization status for Lane 0. This control is paged by the LINK_PAGE control in Register 0x300. Synchronization lost. Synchronization achieved.	0x0	R
		2	CKS0	0 1	Computed checksum status for Lane 0. This control is paged by the LINK_PAGE control in Register 0x300. Checksum is incorrect. Checksum is correct.	0x0	R
		1	FS0	0 1	Frame synchronization status for Lane 0. This control is paged by the LINK_PAGE control in Register 0x300. Synchronization lost. Synchronization achieved.	0x0	R
		0	CGS0	0 1	Code group synchronization status for Lane 0. This control is paged by the LINK_PAGE control in Register 0x300. Synchronization lost. Synchronization achieved.	0x0	R
0x4B1	LINK_STATUS1	7	BDE1	0 1	Bad disparity errors status for Lane 1. This control is paged by the LINK_PAGE control in Register 0x300. Error count < ETH[7:0] value. Error count ≥ ETH[7:0] value.	0x0	R
		6	NIT1	0 1	Not in table errors status for Lane 1. This control is paged by the LINK_PAGE control in Register 0x300. Error count < ETH[7:0] value. Error count ≥ ETH[7:0] value.	0x0	R
		5	UEK1	0 1	Unexpected K character errors status for Lane 1. This control is paged by the LINK_PAGE control in Register 0x300. Error count < ETH[7:0] value. Error count ≥ ETH[7:0] value.	0x0	R
		4	ILD1	0 1	Interlane deskew status for Lane 1. This control is paged by the LINK_PAGE control in Register 0x300. Deskew failed. Deskew achieved.	0x0	R
		3	ILS1	0 1	Initial lane synchronization status for Lane 1. This control is paged by the LINK_PAGE control in Register 0x300. Synchronization lost. Synchronization achieved.	0x0	R
		2	CKS1	0 1	Computed checksum status for Lane 1. This control is paged by the LINK_PAGE control in Register 0x300. Checksum is incorrect. Checksum is correct.	0x0	R
		1	FS1	0 1	Frame synchronization status for Lane 1. This control is paged by the LINK_PAGE control in Register 0x300. Synchronization lost. Synchronization achieved.	0x0	R

Addr.	Name	Bits	Bit Name	Settings	Description	Reset	Access
		0	CGS1	0 1	Code group synchronization status for Lane 1. This control is paged by the LINK_PAGE control in Register 0x300. Synchronization lost. Synchronization achieved.	0x0	R
0x4B2	LINK_STATUS2	7	BDE2	0 1	Bad disparity errors status for Lane 2. This control is paged by the LINK_PAGE control in Register 0x300. Error count < ETH[7:0] value. Error count ≥ ETH[7:0] value.	0x0	R
		6	NIT2	0 1	Not in table errors status for Lane 2. This control is paged by the LINK_PAGE control in Register 0x300. Error count < ETH[7:0] value. Error count ≥ ETH[7:0] value.	0x0	R
		5	UEK2	0 1	Unexpected K character errors status for Lane 2. This control is paged by the LINK_PAGE control in Register 0x300. Error count < ETH[7:0] value. Error count ≥ ETH[7:0] value.	0x0	R
		4	ILD2	0 1	Interlane deskew status for Lane 2. This control is paged by the LINK_PAGE control in Register 0x300. Deskew failed. Deskew achieved.	0x0	R
		3	ILS2	0 1	Initial lane synchronization status for Lane 2. This control is paged by the LINK_PAGE control in Register 0x300. Synchronization lost. Synchronization achieved.	0x0	R
		2	CKS2	0 1	Computed checksum status for Lane 2. This control is paged by the LINK_PAGE control in Register 0x300. Checksum is incorrect. Checksum is correct.	0x0	R
		1	FS2	0 1	Frame synchronization status for Lane 2. This control is paged by the LINK_PAGE control in Register 0x300. Synchronization lost. Synchronization achieved.	0x0	R
		0	CGS2	0 1	Code group synchronization status for Lane 2. This control is paged by the LINK_PAGE control in Register 0x300. Synchronization lost. Synchronization achieved.	0x0	R

Addr.	Name	Bits	Bit Name	Settings	Description	Reset	Access
0x4B3	LINK_STATUS3	7	BDE3	0 1	Bad disparity errors status for Lane 3. This control is paged by the LINK_PAGE control in Register 0x300. Error count < ETH[7:0] value. Error count ≥ ETH[7:0] value.	0x0	R
		6	NIT3	0 1	Not in table errors status for Lane 3. This control is paged by the LINK_PAGE control in Register 0x300. Error count < ETH[7:0] value. Error count ≥ ETH[7:0] value.	0x0	R
		5	UEK3	0 1	Unexpected K character errors status for Lane 3. This control is paged by the LINK_PAGE control in Register 0x300. Error count < ETH[7:0] value. Error count ≥ ETH[7:0] value.	0x0	R
		4	ILD3	0 1	Interlane deskew status for Lane 3. This control is paged by the LINK_PAGE control in Register 0x300. Deskew failed. Deskew achieved.	0x0	R
		3	ILS3	0 1	Initial lane synchronization status for Lane 3. This control is paged by the LINK_PAGE control in Register 0x300. Synchronization lost. Synchronization achieved.	0x0	R
		2	CKS3	0 1	Computed checksum status for Lane 3. This control is paged by the LINK_PAGE control in Register 0x300. Checksum is incorrect. Checksum is correct.	0x0	R
		1	FS3	0 1	Frame synchronization status for Lane 3. This control is paged by the LINK_PAGE control in Register 0x300. Synchronization lost. Synchronization achieved.	0x0	R
		0	CGS3	0 1	Code group synchronization status for Lane 3. This control is paged by the LINK_PAGE control in Register 0x300. Synchronization lost. Synchronization achieved.	0x0	R
0x4B4	LINK_STATUS4	7	BDE4	0 1	Bad disparity errors status for Lane 4. This control is paged by the LINK_PAGE control in Register 0x300. Error count < ETH[7:0] value. Error count ≥ ETH[7:0] value.	0x0	R
		6	NIT4	0 1	Not in table errors status for Lane 4. This control is paged by the LINK_PAGE control in Register 0x300. Error count < ETH[7:0] value. Error count ≥ ETH[7:0] value.	0x0	R
		5	UEK4	0 1	Unexpected K character errors status for Lane 4. This control is paged by the LINK_PAGE control in Register 0x300. Error count < ETH[7:0] value. Error count ≥ ETH[7:0] value.	0x0	R

Addr.	Name	Bits	Bit Name	Settings	Description	Reset	Access
		4	ILD4	0 1	Interlane deskew status for Lane 4. This control is paged by the LINK_PAGE control in Register 0x300. Deskew failed. Deskew achieved.	0x0	R
		3	ILS4	0 1	Initial lane synchronization status for Lane 4. This control is paged by the LINK_PAGE control in Register 0x300. Synchronization lost. Synchronization achieved.	0x0	R
		2	CKS4	0 1	Computed checksum status for Lane 4. This control is paged by the LINK_PAGE control in Register 0x300. Checksum is incorrect. Checksum is correct.	0x0	R
		1	FS4	0 1	Frame synchronization status for Lane 4. This control is paged by the LINK_PAGE control in Register 0x300. Synchronization lost. Synchronization achieved.	0x0	R
		0	CGS4	0 1	Code group synchronization status for Lane 4. This control is paged by the LINK_PAGE control in Register 0x300. Synchronization lost. Synchronization achieved.	0x0	R
0x4B5	LINK_STATUS5	7	BDE5	0 1	Bad disparity errors status for Lane 5. This control is paged by the LINK_PAGE control in Register 0x300. Error count < ETH[7:0] value. Error count ≥ ETH[7:0] value.	0x0	R
		6	NIT5	0 1	Not in table errors status for Lane 5. This control is paged by the LINK_PAGE control in Register 0x300. Error count < ETH[7:0] value. Error count ≥ ETH[7:0] value.	0x0	R
		5	UEK5	0 1	Unexpected K character errors status for Lane 5. This control is paged by the LINK_PAGE control in Register 0x300. Error count < ETH[7:0] value. Error count ≥ ETH[7:0] value.	0x0	R
		4	ILD5	0 1	Interlane deskew status for Lane 5. This control is paged by the LINK_PAGE control in Register 0x300. Deskew failed. Deskew achieved.	0x0	R
		3	ILS5	0 1	Initial lane synchronization status for Lane 5. This control is paged by the LINK_PAGE control in Register 0x300. Synchronization lost. Synchronization achieved.	0x0	R
		2	CKS5	0 1	Computed checksum status for Lane 5. This control is paged by the LINK_PAGE control in Register 0x300. Checksum is incorrect. Checksum is correct.	0x0	R

Addr.	Name	Bits	Bit Name	Settings	Description	Reset	Access
		1	FS5	0 1	Frame synchronization status for Lane 5. This control is paged by the LINK_PAGE control in Register 0x300. Synchronization lost. Synchronization achieved.	0x0	R
		0	CGS5	0 1	Code group synchronization status for Lane 5. This control is paged by the LINK_PAGE control in Register 0x300. Synchronization lost. Synchronization achieved.	0x0	R
0x4B6	LINK_STATUS6	7	BDE6	0 1	Bad disparity errors status for Lane 6. This control is paged by the LINK_PAGE control in Register 0x300. Error count < ETH[7:0] value. Error count ≥ ETH[7:0] value.	0x0	R
		6	NIT6	0 1	Not in table errors status for Lane 6. This control is paged by the LINK_PAGE control in Register 0x300. Error count < ETH[7:0] value. Error count ≥ ETH[7:0] value.	0x0	R
		5	UEK6	0 1	Unexpected K character errors status for Lane 6. This control is paged by the LINK_PAGE control in Register 0x300. Error count < ETH[7:0] value. Error count ≥ ETH[7:0] value.	0x0	R
		4	ILD6	0 1	Interlane deskew status for Lane 6. This control is paged by the LINK_PAGE control in Register 0x300. Deskew failed. Deskew achieved.	0x0	R
		3	ILS6	0 1	Initial lane synchronization status for Lane 6. This control is paged by the LINK_PAGE control in Register 0x300. Synchronization lost. Synchronization achieved.	0x0	R
		2	CKS6	0 1	Computed checksum status for Lane 6. This control is paged by the LINK_PAGE control in Register 0x300. Checksum is incorrect. Checksum is correct.	0x0	R
		1	FS6	0 1	Frame synchronization status for Lane 6. This control is paged by the LINK_PAGE control in Register 0x300. Synchronization lost. Synchronization achieved.	0x0	R
		0	CGS6	0 1	Code group synchronization status for Lane 6. This control is paged by the LINK_PAGE control in Register 0x300. Synchronization lost. Synchronization achieved.	0x0	R

Addr.	Name	Bits	Bit Name	Settings	Description	Reset	Access
0x4B7	LINK_STATUS7	7	BDE7	0 1	Bad disparity errors status for Lane 7. This control is paged by the LINK_PAGE control in Register 0x300. Error count < ETH[7:0] value. Error count ≥ ETH[7:0] value.	0x0	R
		6	NIT7	0 1	Not in table errors status for Lane 7. This control is paged by the LINK_PAGE control in Register 0x300. Error count < ETH[7:0] value. Error count ≥ ETH[7:0] value.	0x0	R
		5	UEK7	0 1	Unexpected K character errors status Lane 7. This control is paged by the LINK_PAGE control in Register 0x300. Error count < ETH[7:0] value. Error count ≥ ETH[7:0] value.	0x0	R
		4	ILD7	0 1	Interlane deskew status for Lane 7. This control is paged by the LINK_PAGE control in Register 0x300. Deskew failed. Deskew achieved.	0x0	R
		3	ILS7	0 1	Initial lane synchronization status for Lane 7. This control is paged by the LINK_PAGE control in Register 0x300. Synchronization lost. Synchronization achieved.	0x0	R
		2	CKS7	0 1	Computed checksum status for Lane 7. This control is paged by the LINK_PAGE control in Register 0x300. Checksum is incorrect. Checksum is correct.	0x0	R
		1	FS7	0 1	Frame synchronization status for Lane 7. This control is paged by the LINK_PAGE control in Register 0x300. Synchronization lost. Synchronization achieved.	0x0	R
		0	CGS7	0 1	Code group synchronization status for Lane 7. This control is paged by the LINK_PAGE control in Register 0x300. Synchronization lost. Synchronization achieved.	0x0	R
0x4B8	JESD_IRQ_ENABLEA	7	EN_BDE		Bad disparity error counter. This control is paged by the LINK_PAGE control in Register 0x300.	0x0	R/W
		6	EN_NIT		Not in table error counter. This control is paged by the LINK_PAGE control in Register 0x300.	0x0	R/W
		5	EN_UEK		Unexpected K error counter. This control is paged by the LINK_PAGE control in Register 0x300.	0x0	R/W
		4	EN_ILD		Interlane deskew. This control is paged by the LINK_PAGE control in Register 0x300.	0x0	R/W
		3	EN_ILS		Initial lane synchronization. This control is paged by the LINK_PAGE control in Register 0x300.	0x0	R/W

Addr.	Name	Bits	Bit Name	Settings	Description	Reset	Access
		2	EN_CKS		Good checksum. This bit compares two checksums: the checksum that the transmitter sent over the link during the ILAS and the checksum that the receiver calculated from the ILAS data that the transmitter sent over the link. The checksum IRQ only looks at data sent by the transmitter and not the checksum programmed into Register 0x45D. This control is paged by the LINK_PAGE control in Register 0x300.	0x0	R/W
		1	EN_FS		Frame synchronization. This control is paged by the LINK_PAGE control in Register 0x300.	0x0	R/W
		0	EN_CGS		Code group synchronization. This control is paged by the LINK_PAGE control in Register 0x300.	0x0	R/W
0x4B9	JESD_IRQ_ENABLEB	[7:1]	RESERVED		Reserved.	0x0	R
		0	EN_ILAS		Configuration mismatch (checked for Lane 0 only). The ILAS IRQ compares the two sets of ILAS data obtained by the receiver. The first set of data is the ILAS data sent over the JESD204B link by the transmitter. The second set of data is the ILAS data programmed into the receiver via the SPI (Register 0x450 to Register 0x45D). If any of the data differs, the IRQ is triggered. All of the ILAS data, including the checksum, is compared. This control is paged by the LINK_PAGE control in Register 0x300.	0x0	R/W
0x4BA	JESD_IRQ_STATUSA	7	IRQ_BDE		Bad disparity error counter. This control is paged by the LINK_PAGE control in Register 0x300.	0x0	R/W
		6	IRQ_NIT		Not in table error counter. This control is paged by the LINK_PAGE control in Register 0x300.	0x0	R/W
		5	IRQ_UEK		Unexpected K error counter. This control is paged by the LINK_PAGE control in Register 0x300.	0x0	R/W
		4	IRQ_ILD		Interlane deskew. This control is paged by the LINK_PAGE control in Register 0x300.	0x0	R/W
		3	IRQ_ILS		Initial lane synchronization. This control is paged by the LINK_PAGE control in Register 0x300.	0x0	R/W
		2	IRQ_CKS		Good checksum. This control is paged by the LINK_PAGE control in Register 0x300.	0x0	R/W
		1	IRQ_FS		Frame synchronization. This control is paged by the LINK_PAGE control in Register 0x300.	0x0	R/W
		0	IRQ_CGS		Code group synchronization. This control is paged by the LINK_PAGE control in Register 0x300.	0x0	R/W
0x4BB	JESD_IRQ_STATUSB	[7:1]	RESERVED		Reserved.	0x0	R
		0	IRQ_ILAS		Configuration mismatch (checked for Lane 0 only). This control is paged by the LINK_PAGE control in Register 0x300.	0x0	R/W

Addr.	Name	Bits	Bit Name	Settings	Description	Reset	Access
0x4BC	IRQ_OUTPUT_MUX_JESD	[7:1]	RESERVED		Reserved.	0x0	R
		0	MUX_JESD_IRQ	0 1	Selects which IRQ pin is connected to the JESD204B IRQx sources. Route the IRQ trigger signal to the $\overline{\text{IRQ0}}$ pin. Route the IRQ trigger signal to the $\overline{\text{IRQ1}}$ pin.	0x0	R/W
0x580	BE_SOFT_OFF_GAIN_CTRL	7	BE_SOFT_OFF_GAIN_EN		Must be 1 to use soft off/on. This control is paged by the MAINDAC_PAGE control in Register 0x008.	0x0	R/W
		[6:3]	RESERVED		Reserved.	0x0	R
		[2:0]	BE_GAIN_RAMP_RATE		Sets ramp rate. The gain ramps from 0 to 1 (or 1 to 0) in 32 steps over $2^{(\text{CODE} + 8)}$ DAC clock periods. This control is paged by the MAINDAC_PAGE control in Register 0x008.	0x0	R/W
0x581	BE_SOFT_OFF_ENABLE	7	ENA_SHORT_PAERR_SOFTOFF		Enable short PA error soft off. This control is paged by the MAINDAC_PAGE control in Register 0x008.	0x1	R/W
		6	ENA_LONG_PAERR_SOFTOFF		Enable long PA error soft off. This control is paged by the MAINDAC_PAGE control in Register 0x008.	0x1	R/W
		[5:4]	RESERVED		Reserved.	0x0	R
		3	ENA_JESD_ERR_SOFTOFF		Enable JESD204B side error soft off. This control is paged by the MAINDAC_PAGE control in Register 0x008.	0x0	R/W
		2	ROTATE_SOFT_OFF_EN		When set to 1, the synchronization logic rotation triggers the DAC output soft off. Register 0x03B, Bit 0 must also be high. This control is paged by the MAINDAC_PAGE control in Register 0x008.	0x1	R/W
		1	TXEN_SOFT_OFF_EN		When set to 1, a TXENx falling edge triggers the DAC output soft off. This control is paged by the MAINDAC_PAGE control in Register 0x008.	0x1	R/W
		0	SPI_SOFT_OFF_EN		Force a soft off when gain is 1. This control is paged by the MAINDAC_PAGE control in Register 0x008.	0x0	R/W
0x582	BE_SOFT_ON_ENABLE	7	SPI_SOFT_ON_EN		Force a soft on when gain is 0. This control is paged by the MAINDAC_PAGE control in Register 0x008.	0x0	R/W
		6	LONG_LEVEL_SOFTON_EN		When set to 1, this bit enables the long level soft on. This control is paged by the MAINDAC_PAGE control in Register 0x008.	0x1	R/W
		[5:0]	RESERVED		Reserved.	0x0	R/W
0x583	LONG_PA_THRES_LSB	[7:0]	LONG_PA_THRESHOLD[7:0]		Long average power threshold for comparison. This control is paged by the MAINDAC_PAGE control in Register 0x008.	0x0	R/W
0x584	LONG_PA_THRES_MSB	[7:5]	RESERVED		Reserved.	0x0	R
		[4:0]	LONG_PA_THRESHOLD[12:8]		Long average power threshold for comparison. This control is paged by the MAINDAC_PAGE control in Register 0x008.	0x0	R/W

Addr.	Name	Bits	Bit Name	Settings	Description	Reset	Access
0x585	LONG_PA_CONTROL	7	LONG_PA_ENABLE		Enable long average power calculation and error detection. This control is paged by the MAINDAC_PAGE control in Register 0x008.	0x0	R/W
		[6:4]	RESERVED		Reserved.	0x0	R
		[3:0]	LONG_PA_AVG_TIME		Sets length of long PA averaging time. This control is paged by the MAINDAC_PAGE control in Register 0x008. Averaging time = $29 + \text{LONG\_PA\_AVG\_TIME}$ (PA clock periods). A PA clock period is calculated by the following: If the main interpolation is $>1\times$ , PA clock period = $4 \times \text{main interpolation} \times \text{DAC clock period}$ . If channel interpolation is $>1\times$ , PA clock period = $8 \times \text{main interpolation} \times \text{DAC clock period}$ . Otherwise, PA clock period = $32 \times \text{DAC clock period}$ .	0x0	R/W
0x586	LONG_PA_POWER_LSB	[7:0]	LONG_PA_POWER[7:0]		Long average power readback. Power detected at data bus = $I^2 + Q^2$ . The data bus calculation only uses the 6 MSBs of the I and Q data bus samples. This control is paged by the MAINDAC_PAGE control in Register 0x008.	0x0	R
0x587	LONG_PA_POWER_MSB	[7:5]	RESERVED		Reserved.	0x0	R
		[4:0]	LONG_PA_POWER[12:8]		Long average power readback. Power detected at data bus = $I^2 + Q^2$ . The data bus calculation only uses the 6 MSBs of the I and Q data bus samples. This control is paged by the MAINDAC_PAGE control in Register 0x008.	0x0	R
0x588	SHORT_PA_THRES_LSB	[7:0]	SHORT_PA_THRESHOLD[7:0]		Short average power threshold for comparison. This control is paged by the MAINDAC_PAGE control in Register 0x008.	0x0	R/W
0x589	SHORT_PA_THRES_MSB	[7:5]	RESERVED		Reserved.	0x0	R
		[4:0]	SHORT_PA_THRESHOLD[12:8]		Short average power threshold for comparison. This control is paged by the MAINDAC_PAGE control in Register 0x008.	0x0	R/W
0x58A	SHORT_PA_CONTROL	7	SHORT_PA_ENABLE		Enable short average power calculation and error detection. This control is paged by the MAINDAC_PAGE control in Register 0x008.	0x0	R/W
		[6:2]	RESERVED		Reserved.	0x0	R
		[1:0]	SHORT_PA_AVG_TIME		Sets length of short PA averaging. This control is paged by the MAINDAC_PAGE control in Register 0x008. Averaging time = $2^{\text{SHORT\_PA\_AVG\_TIME}}$ (PA clock periods). A PA clock period is calculated by the following: If the main interpolation is $>1\times$ , PA clock period = $4 \times \text{main interpolation} \times \text{DAC clock period}$ . If channel interpolation is $>1\times$ , PA clock period = $8 \times \text{main interpolation} \times \text{DAC clock period}$ . Otherwise, PA clock period = $32 \times \text{DAC clock period}$ .	0x0	R/W

Addr.	Name	Bits	Bit Name	Settings	Description	Reset	Access
0x58B	SHORT_PA_POWER_LSB	[7:0]	SHORT_PA_POWER[7:0]		Short average power readback. Power detected at data bus = $I^2 + Q^2$ . The data bus calculation only uses the 6 MSBs of the I and Q data bus samples. This control is paged by the MAINDAC_PAGE control in Register 0x008.	0x0	R
0x58C	SHORT_PA_POWER_MSB	[7:5]	RESERVED		Reserved.	0x0	R
		[4:0]	SHORT_PA_POWER[12:8]		Short average power readback. Power detected at data bus = $I^2 + Q^2$ . The data bus calculation only uses the 6 MSBs of the I and Q data bus samples. This control is paged by the MAINDAC_PAGE control in Register 0x008.	0x0	R
0x58D	TXEN_SM_0	[7:1]	RESERVED		Reserved.	0x1	R/W
		0	ENA_TXENSM		Enable TXEN state machine. This control is paged by the MAINDAC_PAGE control in Register 0x008.	0x0	R/W
0x596	BLANKING_CTRL	[7:4]	RESERVED		Reserved.	0x0	R
		3	SPI_TXEN		If ENA_SPI_TXEN (Bit 2 of this register) = 1, the value of this register is the value of the TXENx status. This control is paged by the MAINDAC_PAGE control in Register 0x008.	0x0	R/W
		2	ENA_SPI_TXEN		Enable TXENx control via the SPI by setting this bit to 1. This control is paged by the MAINDAC_PAGE control in Register 0x008.	0x0	R/W
		[1:0]	RESERVED		Reserved.	0x0	R
0x597	JESD_PA_INT0	[7:0]	JESD_PA_INT_CNTRL[7:0]		Each bit enables a JESD204B PA interrupt. Bit 8 = CGS. Bit 7 = frame sync. Bit 6 = good check sum. Bit 5 = initial lane sync. Bit 4 = interlane deskew. Bit 3 = bad disparity error counter. Bit 2 = NIT error counter. Bit 1 = UEK error counter. Bit 0 = lane FIFO overflow or underflow.	0x0	R/W
0x598	JESD_PA_INT1	[7:1]	RESERVED		Reserved.	0x0	R
		0	JESD_PA_INT_CNTRL[8]		Each bit enables a JESD204B PA interrupt. Bit 8 = CGS Bit 7 = frame sync. Bit 6 = good check sum. Bit 5 = initial lane sync. Bit 4 = interlane deskew. Bit 3 = bad disparity error counter. Bit 2 = NIT error counter. Bit 1 = UEK error counter. Bit 0 = lane FIFO overflow or underflow.	0x0	R/W
0x599	TXEN_FLUSH_CTRL0	[7:1]	RESERVED		Reserved.	0x0	R
		0	SPI_FLUSH_EN		Enable datapath flush. This control is paged by the MAINDAC_PAGE control in Register 0x008.	0x1	R/W
0x705	NVM_LOADER_EN	[7:1]	RESERVED		Reserved.	0x0	R
		0	NVM_BLR_EN		Enable bootloader. This bit self clears when the boot loader completes or fails.	0x0	R/W

Addr.	Name	Bits	Bit Name	Settings	Description	Reset	Access
0x790	DACPLL_PDCTRL0	7	PLL_PD5		PLL power-down control. Write this bit to 1 if bypassing the PLL. If using the PLL, keep this value at default (0).	0x0	R/W
		[6:4]	PLL_PD4		PLL power-down control. Write this bit to 1 if bypassing the PLL. If using the PLL, keep this value at default (0).	0x0	R/W
		3	PLL_PD3		PLL power-down control. Write this bit to 1 if bypassing the PLL. If using the PLL, keep this value default (0).	0x0	R/W
		2	PLL_PD2		PLL power-down control. Write this bit to 1 if bypassing the PLL. If using the PLL, keep this value at default (0).	0x0	R/W
		1	PLL_PD1		PLL power-down control. Write this bit to 1 if bypassing the PLL. If using the PLL, write this bit to 0.	0x1	R/W
		0	PLL_PD0		PLL power-down control. Write this bit to 1 if bypassing the PLL. If using the PLL, keep this value at default (0).	0x0	R/W
0x791	DACPLL_PDCTRL1	[7:5]	RESERVED		Reserved.	0x0	R/W
		4	PLL_PD10		PLL power-down control. Write this bit to 1 if bypassing the PLL. If using the PLL, keep this value at default (0).	0x0	R/W
		3	PLL_PD9		PLL power-down control. Write this bit to 1 if bypassing the PLL. If using the PLL, keep this value at default (0).	0x0	R/W
		2	PLL_PD8		PLL power-down control. Write this bit to 1 if bypassing the PLL. If using the PLL, keep this value at default (0).	0x0	R/W
		1	PLL_PD7		PLL power-down control. Write this bit to 1 if bypassing the PLL. If using the PLL, keep this value at default (0).	0x0	R/W
		0	PLL_PD6		PLL power-down control. Write this bit to 1 if bypassing the PLL. If using the PLL, keep this value at default (0).	0x0	R/W
0x792	DACPLL_CTRL0	[7:2]	RESERVED		Reserved.	0x0	R
		1	D_CAL_RESET		Resets VCO calibration.	0x1	R/W
		0	D_RESET_VCO_DIV		Setting this high holds the VCO output divider in reset. This has the effect of turning off the input (and output) of the ADC clock driver.	0x0	R/W
0x793	DACPLL_CTRL1	[7:2]	RESERVED		Reserved.	0x0	R
		[1:0]	M_DIVIDER-1	0 1 10 11	Programmable predivider value for PFD (in $n - 1$ notation). $M\_DIVIDER = PLL$ reference clock/PFD frequency. For optimal spectral performance, choose an M divider setting that selects a high PFD frequency within the allowable PFD range. Divide by 1. Divide by 2. Divide by 3. Divide by 4.	0x0	R/W
0x794	DACPLL_CTRL2	[7:6]	RESERVED		Reserved.	0x0	R/W
		[5:0]	DACPLL_CP		Charge pump current control. Charge pump current = $100 \mu A + code \times 100 \mu A$ .	0x4	R/W
0x795	DACPLL_CTRL3	[7:4]	RESERVED		Reserved.	0x0	R/W
		[3:0]	D_CP_CALBITS		DAC PLL optimization control.	0x8	R/W

Addr.	Name	Bits	Bit Name	Settings	Description	Reset	Access
0x796	DACPLL_CTRL4	[7:4]	PLL_CTRL0		DAC PLL optimization control.	0xD	R/W
		[3:0]	RESERVED		Reserved.	0x2	R/W
0x797	DACPLL_CTRL5	[7:6]	RESERVED		Reserved.	0x0	R/W
		[5:0]	PLL_CTRL1		DAC PLL optimization control.	0x20	R/W
0x798	DACPLL_CTRL6	7	RESERVED		Reserved.	0x0	R
		6	PLL_CTRL3		DAC PLL optimization control.	0x0	R/W
		[5:0]	PLL_CTRL2		DAC PLL optimization control.	0x1C	R/W
0x799	DACPLL_CTRL7	[7:6]	ADC_CLK_DIVIDER	0 1 10 11	ADC clock output divider. Divide by 1. Divide by 2. Divide by 3. Divide by 4.	0x0	R/W
		[5:0]	N_DIVIDER		Programmable divide by N value from 2 to 50. $N\_DIVIDER = (DAC\ frequency \times M\_DIVIDER) / (8 \times reference\ clock\ frequency)$ .	0x8	R/W
0x7A0	DACPLL_CTRL9	[7:6]	RESERVED		Reserved.	0x2	R/W
		5	D_EN_VAR_FINE_PRE		DAC PLL control.	0x0	R/W
		[4:3]	RESERVED		Reserved.	0x2	R/W
		2	D_EN_VAR_COARSE_PRE		DAC PLL control.	0x0	R/W
		[1:0]	RESERVED		Reserved.	0x0	R/W
0x7A2	DACPLL_CTRL10	7	RESERVED		Reserved.	0x0	R
		[6:5]	D_REGULATOR_CAL_WAIT		DAC PLL optimization control.	0x1	R/W
		[4:3]	D_VCO_CAL_WAIT		DAC PLL optimization control.	0x2	R/W
		[2:1]	D_VCO_CAL_CYCLES		DAC PLL optimization control.	0x2	R/W
		0	RESERVED		Reserved.	0x1	R/W
0x7B5	PLL_STATUS	[7:1]	RESERVED		Reserved.	0x0	R
		0	PLL_LOCK		DAC PLL lock status.	0x0	R
0x800	DDSM_HOPF_CTRL	[7:6]	DDSM_HOPF_MODE	0 1 10	Frequency switch mode. This control is paged by the MAINDAC_PAGE control in Register 0x008. Phase continuous switch. Changes frequency tuning word, and the phase accumulator continues to accumulate to the new FTW. Phase discontinuous switch. Changes the frequency tuning word and resets the phase accumulator. Phase coherent switch. This mode starts all 32 NCO phase accumulators to begin counting simultaneously and all continue counting regardless of which individual NCO output is selected.	0x0	R/W
		5	RESERVED		Reserved.	0x0	R/W
		[4:0]	DDSM_HOPF_SEL		Hopping frequency selection control. Enter the number of the FTW (from FTW 0 to FTW31) to select the output of that NCO. This control is paged by the MAINDAC_PAGE control in Register 0x008.	0x0	R/W

Addr.	Name	Bits	Bit Name	Settings	Description	Reset	Access
0x806	DDSM_HOPF_FTW1_0	[7:0]	DDSM_HOPF_FTW1[7:0]		Hopping frequency FTW1. This control is paged by the MAINDAC_PAGE control in Register 0x008.	0x0	R/W
0x807	DDSM_HOPF_FTW1_1	[7:0]	DDSM_HOPF_FTW1[15:8]		Hopping frequency FTW1. This control is paged by the MAINDAC_PAGE control in Register 0x008.	0x0	R/W
0x808	DDSM_HOPF_FTW1_2	[7:0]	DDSM_HOPF_FTW1[23:16]		Hopping frequency FTW1. This control is paged by the MAINDAC_PAGE control in Register 0x008.	0x0	R/W
0x809	DDSM_HOPF_FTW1_3	[7:0]	DDSM_HOPF_FTW1[31:24]		Hopping frequency FTW1. This control is paged by the MAINDAC_PAGE control in Register 0x008.	0x0	R/W
0x80A	DDSM_HOPF_FTW2_0	[7:0]	DDSM_HOPF_FTW2[7:0]		Hopping frequency FTW2. This control is paged by the MAINDAC_PAGE control in Register 0x008.	0x0	R/W
0x80B	DDSM_HOPF_FTW2_1	[7:0]	DDSM_HOPF_FTW2[15:8]		Hopping frequency FTW2. This control is paged by the MAINDAC_PAGE control in Register 0x008.	0x0	R/W
0x80C	DDSM_HOPF_FTW2_2	[7:0]	DDSM_HOPF_FTW2[23:16]		Hopping frequency FTW2. This control is paged by the MAINDAC_PAGE control in Register 0x008.	0x0	R/W
0x80D	DDSM_HOPF_FTW2_3	[7:0]	DDSM_HOPF_FTW2[31:24]		Hopping frequency FTW2. This control is paged by the MAINDAC_PAGE control in Register 0x008.	0x0	R/W
0x80E	DDSM_HOPF_FTW3_0	[7:0]	DDSM_HOPF_FTW3[7:0]		Hopping frequency FTW3. This control is paged by the MAINDAC_PAGE control in Register 0x008.	0x0	R/W
0x80F	DDSM_HOPF_FTW3_1	[7:0]	DDSM_HOPF_FTW3[15:8]		Hopping frequency FTW3. This control is paged by the MAINDAC_PAGE control in Register 0x008.	0x0	R/W
0x810	DDSM_HOPF_FTW3_2	[7:0]	DDSM_HOPF_FTW3[23:16]		Hopping frequency FTW3. This control is paged by the MAINDAC_PAGE control in Register 0x008.	0x0	R/W
0x811	DDSM_HOPF_FTW3_3	[7:0]	DDSM_HOPF_FTW3[31:24]		Hopping frequency FTW3. This control is paged by the MAINDAC_PAGE control in Register 0x008.	0x0	R/W
0x812	DDSM_HOPF_FTW4_0	[7:0]	DDSM_HOPF_FTW4[7:0]		Hopping frequency FTW4. This control is paged by the MAINDAC_PAGE control in Register 0x008.	0x0	R/W
0x813	DDSM_HOPF_FTW4_1	[7:0]	DDSM_HOPF_FTW4[15:8]		Hopping frequency FTW4. This control is paged by the MAINDAC_PAGE control in Register 0x008.	0x0	R/W
0x814	DDSM_HOPF_FTW4_2	[7:0]	DDSM_HOPF_FTW4[23:16]		Hopping frequency FTW4. This control is paged by the MAINDAC_PAGE control in Register 0x008.	0x0	R/W
0x815	DDSM_HOPF_FTW4_3	[7:0]	DDSM_HOPF_FTW4[31:24]		Hopping frequency FTW4. This control is paged by the MAINDAC_PAGE control in Register 0x008.	0x0	R/W
0x816	DDSM_HOPF_FTW5_0	[7:0]	DDSM_HOPF_FTW5[7:0]		Hopping frequency FTW5. This control is paged by the MAINDAC_PAGE control in Register 0x008.	0x0	R/W
0x817	DDSM_HOPF_FTW5_1	[7:0]	DDSM_HOPF_FTW5[15:8]		Hopping frequency FTW5. This control is paged by the MAINDAC_PAGE control in Register 0x008.	0x0	R/W
0x818	DDSM_HOPF_FTW5_2	[7:0]	DDSM_HOPF_FTW5[23:16]		Hopping frequency FTW5. This control is paged by the MAINDAC_PAGE control in Register 0x008.	0x0	R/W

Addr.	Name	Bits	Bit Name	Settings	Description	Reset	Access
0x819	DDSM_HOPF_FTW5_3	[7:0]	DDSM_HOPF_FTW5[31:24]		Hopping frequency FTW5. This control is paged by the MAINDAC_PAGE control in Register 0x008.	0x0	R/W
0x81A	DDSM_HOPF_FTW6_0	[7:0]	DDSM_HOPF_FTW6[7:0]		Hopping frequency FTW6. This control is paged by the MAINDAC_PAGE control in Register 0x008.	0x0	R/W
0x81B	DDSM_HOPF_FTW6_1	[7:0]	DDSM_HOPF_FTW6[15:8]		Hopping frequency FTW6. This control is paged by the MAINDAC_PAGE control in Register 0x008.	0x0	R/W
0x81C	DDSM_HOPF_FTW6_2	[7:0]	DDSM_HOPF_FTW6[23:16]		Hopping frequency FTW6. This control is paged by the MAINDAC_PAGE control in Register 0x008.	0x0	R/W
0x81D	DDSM_HOPF_FTW6_3	[7:0]	DDSM_HOPF_FTW6[31:24]		Hopping frequency FTW6. This control is paged by the MAINDAC_PAGE control in Register 0x008.	0x0	R/W
0x81E	DDSM_HOPF_FTW7_0	[7:0]	DDSM_HOPF_FTW7[7:0]		Hopping frequency FTW7. This control is paged by the MAINDAC_PAGE control in Register 0x008.	0x0	R/W
0x81F	DDSM_HOPF_FTW7_1	[7:0]	DDSM_HOPF_FTW7[15:8]		Hopping frequency FTW7. This control is paged by the MAINDAC_PAGE control in Register 0x008.	0x0	R/W
0x820	DDSM_HOPF_FTW7_2	[7:0]	DDSM_HOPF_FTW7[23:16]		Hopping frequency FTW7. This control is paged by the MAINDAC_PAGE control in Register 0x008.	0x0	R/W
0x821	DDSM_HOPF_FTW7_3	[7:0]	DDSM_HOPF_FTW7[31:24]		Hopping frequency FTW7. This control is paged by the MAINDAC_PAGE control in Register 0x008.	0x0	R/W
0x822	DDSM_HOPF_FTW8_0	[7:0]	DDSM_HOPF_FTW8[7:0]		Hopping frequency FTW8. This control is paged by the MAINDAC_PAGE control in Register 0x008.	0x0	R/W
0x823	DDSM_HOPF_FTW8_1	[7:0]	DDSM_HOPF_FTW8[15:8]		Hopping frequency FTW8. This control is paged by the MAINDAC_PAGE control in Register 0x008.	0x0	R/W
0x824	DDSM_HOPF_FTW8_2	[7:0]	DDSM_HOPF_FTW8[23:16]		Hopping frequency FTW8. This control is paged by the MAINDAC_PAGE control in Register 0x008.	0x0	R/W
0x825	DDSM_HOPF_FTW8_3	[7:0]	DDSM_HOPF_FTW8[31:24]		Hopping frequency FTW8. This control is paged by the MAINDAC_PAGE control in Register 0x008.	0x0	R/W
0x826	DDSM_HOPF_FTW9_0	[7:0]	DDSM_HOPF_FTW9[7:0]		Hopping frequency FTW9. This control is paged by the MAINDAC_PAGE control in Register 0x008.	0x0	R/W
0x827	DDSM_HOPF_FTW9_1	[7:0]	DDSM_HOPF_FTW9[15:8]		Hopping frequency FTW9. This control is paged by the MAINDAC_PAGE control in Register 0x008.	0x0	R/W
0x828	DDSM_HOPF_FTW9_2	[7:0]	DDSM_HOPF_FTW9[23:16]		Hopping frequency FTW9. This control is paged by the MAINDAC_PAGE control in Register 0x008.	0x0	R/W
0x829	DDSM_HOPF_FTW9_3	[7:0]	DDSM_HOPF_FTW9[31:24]		Hopping frequency FTW9. This control is paged by the MAINDAC_PAGE control in Register 0x008.	0x0	R/W
0x82A	DDSM_HOPF_FTW10_0	[7:0]	DDSM_HOPF_FTW10[7:0]		Hopping frequency FTW10. This control is paged by the MAINDAC_PAGE control in Register 0x008.	0x0	R/W
0x82B	DDSM_HOPF_FTW10_1	[7:0]	DDSM_HOPF_FTW10[15:8]		Hopping frequency FTW10. This control is paged by the MAINDAC_PAGE control in Register 0x008.	0x0	R/W

Addr.	Name	Bits	Bit Name	Settings	Description	Reset	Access
0x82C	DDSM_HOPF_FTW10_2	[7:0]	DDSM_HOPF_FTW10[23:16]		Hopping frequency FTW10. This control is paged by the MAINDAC_PAGE control in Register 0x008.	0x0	R/W
0x82D	DDSM_HOPF_FTW10_3	[7:0]	DDSM_HOPF_FTW10[31:24]		Hopping frequency FTW10. This control is paged by the MAINDAC_PAGE control in Register 0x008.	0x0	R/W
0x82E	DDSM_HOPF_FTW11_0	[7:0]	DDSM_HOPF_FTW11[7:0]		Hopping frequency FTW11. This control is paged by the MAINDAC_PAGE control in Register 0x008.	0x0	R/W
0x82F	DDSM_HOPF_FTW11_1	[7:0]	DDSM_HOPF_FTW11[15:8]		Hopping frequency FTW11. This control is paged by the MAINDAC_PAGE control in Register 0x008.	0x0	R/W
0x830	DDSM_HOPF_FTW11_2	[7:0]	DDSM_HOPF_FTW11[23:16]		Hopping frequency FTW11. This control is paged by the MAINDAC_PAGE control in Register 0x008.	0x0	R/W
0x831	DDSM_HOPF_FTW11_3	[7:0]	DDSM_HOPF_FTW11[31:24]		Hopping frequency FTW11. This control is paged by the MAINDAC_PAGE control in Register 0x008.	0x0	R/W
0x832	DDSM_HOPF_FTW12_0	[7:0]	DDSM_HOPF_FTW12[7:0]		Hopping frequency FTW12. This control is paged by the MAINDAC_PAGE control in Register 0x008.	0x0	R/W
0x833	DDSM_HOPF_FTW12_1	[7:0]	DDSM_HOPF_FTW12[15:8]		Hopping frequency FTW12. This control is paged by the MAINDAC_PAGE control in Register 0x008.	0x0	R/W
0x834	DDSM_HOPF_FTW12_2	[7:0]	DDSM_HOPF_FTW12[23:16]		Hopping frequency FTW12. This control is paged by the MAINDAC_PAGE control in Register 0x008.	0x0	R/W
0x835	DDSM_HOPF_FTW12_3	[7:0]	DDSM_HOPF_FTW12[31:24]		Hopping frequency FTW12. This control is paged by the MAINDAC_PAGE control in Register 0x008.	0x0	R/W
0x836	DDSM_HOPF_FTW13_0	[7:0]	DDSM_HOPF_FTW13[7:0]		Hopping frequency FTW13. This control is paged by the MAINDAC_PAGE control in Register 0x008.	0x0	R/W
0x837	DDSM_HOPF_FTW13_1	[7:0]	DDSM_HOPF_FTW13[15:8]		Hopping frequency FTW13. This control is paged by the MAINDAC_PAGE control in Register 0x008.	0x0	R/W
0x838	DDSM_HOPF_FTW13_2	[7:0]	DDSM_HOPF_FTW13[23:16]		Hopping frequency FTW13. This control is paged by the MAINDAC_PAGE control in Register 0x008.	0x0	R/W
0x839	DDSM_HOPF_FTW13_3	[7:0]	DDSM_HOPF_FTW13[31:24]		Hopping frequency FTW13. This control is paged by the MAINDAC_PAGE control in Register 0x008.	0x0	R/W
0x83A	DDSM_HOPF_FTW14_0	[7:0]	DDSM_HOPF_FTW14[7:0]		Hopping frequency FTW14. This control is paged by the MAINDAC_PAGE control in Register 0x008.	0x0	R/W
0x83B	DDSM_HOPF_FTW14_1	[7:0]	DDSM_HOPF_FTW14[15:8]		Hopping frequency FTW14. This control is paged by the MAINDAC_PAGE control in Register 0x008.	0x0	R/W
0x83C	DDSM_HOPF_FTW14_2	[7:0]	DDSM_HOPF_FTW14[23:16]		Hopping frequency FTW14. This control is paged by the MAINDAC_PAGE control in Register 0x008.	0x0	R/W
0x83D	DDSM_HOPF_FTW14_3	[7:0]	DDSM_HOPF_FTW14[31:24]		Hopping frequency FTW14. This control is paged by the MAINDAC_PAGE control in Register 0x008.	0x0	R/W
0x83E	DDSM_HOPF_FTW15_0	[7:0]	DDSM_HOPF_FTW15[7:0]		Hopping frequency FTW15. This control is paged by the MAINDAC_PAGE control in Register 0x008.	0x0	R/W

Addr.	Name	Bits	Bit Name	Settings	Description	Reset	Access
0x83F	DDSM_HOPF_FTW15_1	[7:0]	DDSM_HOPF_FTW15[15:8]		Hopping frequency FTW15. This control is paged by the MAINDAC_PAGE control in Register 0x008.	0x0	R/W
0x840	DDSM_HOPF_FTW15_2	[7:0]	DDSM_HOPF_FTW15[23:16]		Hopping frequency FTW15. This control is paged by the MAINDAC_PAGE control in Register 0x008.	0x0	R/W
0x841	DDSM_HOPF_FTW15_3	[7:0]	DDSM_HOPF_FTW15[31:24]		Hopping frequency FTW15. This control is paged by the MAINDAC_PAGE control in Register 0x008.	0x0	R/W
0x842	DDSM_HOPF_FTW16_0	[7:0]	DDSM_HOPF_FTW16[7:0]		Hopping frequency FTW16. This control is paged by the MAINDAC_PAGE control in Register 0x008.	0x0	R/W
0x843	DDSM_HOPF_FTW16_1	[7:0]	DDSM_HOPF_FTW16[15:8]		Hopping frequency FTW16. This control is paged by the MAINDAC_PAGE control in Register 0x008.	0x0	R/W
0x844	DDSM_HOPF_FTW16_2	[7:0]	DDSM_HOPF_FTW16[23:16]		Hopping frequency FTW16. This control is paged by the MAINDAC_PAGE control in Register 0x008.	0x0	R/W
0x845	DDSM_HOPF_FTW16_3	[7:0]	DDSM_HOPF_FTW16[31:24]		Hopping frequency FTW16. This control is paged by the MAINDAC_PAGE control in Register 0x008.	0x0	R/W
0x846	DDSM_HOPF_FTW17_0	[7:0]	DDSM_HOPF_FTW17[7:0]		Hopping frequency FTW17. This control is paged by the MAINDAC_PAGE control in Register 0x008.	0x0	R/W
0x847	DDSM_HOPF_FTW17_1	[7:0]	DDSM_HOPF_FTW17[15:8]		Hopping frequency FTW17. This control is paged by the MAINDAC_PAGE control in Register 0x008.	0x0	R/W
0x848	DDSM_HOPF_FTW17_2	[7:0]	DDSM_HOPF_FTW17[23:16]		Hopping frequency FTW17. This control is paged by the MAINDAC_PAGE control in Register 0x008.	0x0	R/W
0x849	DDSM_HOPF_FTW17_3	[7:0]	DDSM_HOPF_FTW17[31:24]		Hopping frequency FTW17. This control is paged by the MAINDAC_PAGE control in Register 0x008.	0x0	R/W
0x84A	DDSM_HOPF_FTW18_0	[7:0]	DDSM_HOPF_FTW18[7:0]		Hopping frequency FTW18. This control is paged by the MAINDAC_PAGE control in Register 0x008.	0x0	R/W
0x84B	DDSM_HOPF_FTW18_1	[7:0]	DDSM_HOPF_FTW18[15:8]		Hopping frequency FTW18. This control is paged by the MAINDAC_PAGE control in Register 0x008.	0x0	R/W
0x84C	DDSM_HOPF_FTW18_2	[7:0]	DDSM_HOPF_FTW18[23:16]		Hopping frequency FTW18. This control is paged by the MAINDAC_PAGE control in Register 0x008.	0x0	R/W
0x84D	DDSM_HOPF_FTW18_3	[7:0]	DDSM_HOPF_FTW18[31:24]		Hopping frequency FTW18. This control is paged by the MAINDAC_PAGE control in Register 0x008.	0x0	R/W
0x84E	DDSM_HOPF_FTW19_0	[7:0]	DDSM_HOPF_FTW19[7:0]		Hopping frequency FTW19. This control is paged by the MAINDAC_PAGE control in Register 0x008.	0x0	R/W
0x84F	DDSM_HOPF_FTW19_1	[7:0]	DDSM_HOPF_FTW19[15:8]		Hopping frequency FTW19. This control is paged by the MAINDAC_PAGE control in Register 0x008.	0x0	R/W
0x850	DDSM_HOPF_FTW19_2	[7:0]	DDSM_HOPF_FTW19[23:16]		Hopping frequency FTW19. This control is paged by the MAINDAC_PAGE control in Register 0x008.	0x0	R/W
0x851	DDSM_HOPF_FTW19_3	[7:0]	DDSM_HOPF_FTW19[31:24]		Hopping frequency FTW19. This control is paged by the MAINDAC_PAGE control in Register 0x008.	0x0	R/W

Addr.	Name	Bits	Bit Name	Settings	Description	Reset	Access
0x852	DDSM_HOPF_FTW20_0	[7:0]	DDSM_HOPF_FTW20[7:0]		Hopping frequency FTW20. This control is paged by the MAINDAC_PAGE control in Register 0x008.	0x0	R/W
0x853	DDSM_HOPF_FTW20_1	[7:0]	DDSM_HOPF_FTW20[15:8]		Hopping frequency FTW20. This control is paged by the MAINDAC_PAGE control in Register 0x008.	0x0	R/W
0x854	DDSM_HOPF_FTW20_2	[7:0]	DDSM_HOPF_FTW20[23:16]		Hopping frequency FTW20. This control is paged by the MAINDAC_PAGE control in Register 0x008.	0x0	R/W
0x855	DDSM_HOPF_FTW20_3	[7:0]	DDSM_HOPF_FTW20[31:24]		Hopping frequency FTW20. This control is paged by the MAINDAC_PAGE control in Register 0x008.	0x0	R/W
0x856	DDSM_HOPF_FTW21_0	[7:0]	DDSM_HOPF_FTW21[7:0]		Hopping frequency FTW21. This control is paged by the MAINDAC_PAGE control in Register 0x008.	0x0	R/W
0x857	DDSM_HOPF_FTW21_1	[7:0]	DDSM_HOPF_FTW21[15:8]		Hopping frequency FTW21. This control is paged by the MAINDAC_PAGE control in Register 0x008.	0x0	R/W
0x858	DDSM_HOPF_FTW21_2	[7:0]	DDSM_HOPF_FTW21[23:16]		Hopping frequency FTW21. This control is paged by the MAINDAC_PAGE control in Register 0x008.	0x0	R/W
0x859	DDSM_HOPF_FTW21_3	[7:0]	DDSM_HOPF_FTW21[31:24]		Hopping frequency FTW21. This control is paged by the MAINDAC_PAGE control in Register 0x008.	0x0	R/W
0x85A	DDSM_HOPF_FTW22_0	[7:0]	DDSM_HOPF_FTW22[7:0]		Hopping frequency FTW22. This control is paged by the MAINDAC_PAGE control in Register 0x008.	0x0	R/W
0x85B	DDSM_HOPF_FTW22_1	[7:0]	DDSM_HOPF_FTW22[15:8]		Hopping frequency FTW22. This control is paged by the MAINDAC_PAGE control in Register 0x008.	0x0	R/W
0x85C	DDSM_HOPF_FTW22_2	[7:0]	DDSM_HOPF_FTW22[23:16]		Hopping frequency FTW22. This control is paged by the MAINDAC_PAGE control in Register 0x008.	0x0	R/W
0x85D	DDSM_HOPF_FTW22_3	[7:0]	DDSM_HOPF_FTW22[31:24]		Hopping frequency FTW22. This control is paged by the MAINDAC_PAGE control in Register 0x008.	0x0	R/W
0x85E	DDSM_HOPF_FTW23_0	[7:0]	DDSM_HOPF_FTW23[7:0]		Hopping frequency FTW23. This control is paged by the MAINDAC_PAGE control in Register 0x008.	0x0	R/W
0x85F	DDSM_HOPF_FTW23_1	[7:0]	DDSM_HOPF_FTW23[15:8]		Hopping frequency FTW23. This control is paged by the MAINDAC_PAGE control in Register 0x008.	0x0	R/W
0x860	DDSM_HOPF_FTW23_2	[7:0]	DDSM_HOPF_FTW23[23:16]		Hopping frequency FTW23. This control is paged by the MAINDAC_PAGE control in Register 0x008.	0x0	R/W
0x861	DDSM_HOPF_FTW23_3	[7:0]	DDSM_HOPF_FTW23[31:24]		Hopping frequency FTW23. This control is paged by the MAINDAC_PAGE control in Register 0x008.	0x0	R/W
0x862	DDSM_HOPF_FTW24_0	[7:0]	DDSM_HOPF_FTW24[7:0]		Hopping frequency FTW24. This control is paged by the MAINDAC_PAGE control in Register 0x008.	0x0	R/W
0x863	DDSM_HOPF_FTW24_1	[7:0]	DDSM_HOPF_FTW24[15:8]		Hopping frequency FTW24. This control is paged by the MAINDAC_PAGE control in Register 0x008.	0x0	R/W
0x864	DDSM_HOPF_FTW24_2	[7:0]	DDSM_HOPF_FTW24[23:16]		Hopping frequency FTW24. This control is paged by the MAINDAC_PAGE control in Register 0x008.	0x0	R/W

Addr.	Name	Bits	Bit Name	Settings	Description	Reset	Access
0x865	DDSM_HOPF_FTW24_3	[7:0]	DDSM_HOPF_FTW24[31:24]		Hopping frequency FTW24. This control is paged by the MAINDAC_PAGE control in Register 0x008.	0x0	R/W
0x866	DDSM_HOPF_FTW25_0	[7:0]	DDSM_HOPF_FTW25[7:0]		Hopping frequency FTW25. This control is paged by the MAINDAC_PAGE control in Register 0x008.	0x0	R/W
0x867	DDSM_HOPF_FTW25_1	[7:0]	DDSM_HOPF_FTW25[15:8]		Hopping frequency FTW25. This control is paged by the MAINDAC_PAGE control in Register 0x008.	0x0	R/W
0x868	DDSM_HOPF_FTW25_2	[7:0]	DDSM_HOPF_FTW25[23:16]		Hopping frequency FTW25. This control is paged by the MAINDAC_PAGE control in Register 0x008.	0x0	R/W
0x869	DDSM_HOPF_FTW25_3	[7:0]	DDSM_HOPF_FTW25[31:24]		Hopping frequency FTW25. This control is paged by the MAINDAC_PAGE control in Register 0x008.	0x0	R/W
0x86A	DDSM_HOPF_FTW26_0	[7:0]	DDSM_HOPF_FTW26[7:0]		Hopping frequency FTW26. This control is paged by the MAINDAC_PAGE control in Register 0x008.	0x0	R/W
0x86B	DDSM_HOPF_FTW26_1	[7:0]	DDSM_HOPF_FTW26[15:8]		Hopping frequency FTW26. This control is paged by the MAINDAC_PAGE control in Register 0x008.	0x0	R/W
0x86C	DDSM_HOPF_FTW26_2	[7:0]	DDSM_HOPF_FTW26[23:16]		Hopping frequency FTW26. This control is paged by the MAINDAC_PAGE control in Register 0x008.	0x0	R/W
0x86D	DDSM_HOPF_FTW26_3	[7:0]	DDSM_HOPF_FTW26[31:24]		Hopping frequency FTW26. This control is paged by the MAINDAC_PAGE control in Register 0x008.	0x0	R/W
0x86E	DDSM_HOPF_FTW27_0	[7:0]	DDSM_HOPF_FTW27[7:0]		Hopping frequency FTW27. This control is paged by the MAINDAC_PAGE control in Register 0x008.	0x0	R/W
0x86F	DDSM_HOPF_FTW27_1	[7:0]	DDSM_HOPF_FTW27[15:8]		Hopping frequency FTW27. This control is paged by the MAINDAC_PAGE control in Register 0x008.	0x0	R/W
0x870	DDSM_HOPF_FTW27_2	[7:0]	DDSM_HOPF_FTW27[23:16]		Hopping frequency FTW27. This control is paged by the MAINDAC_PAGE control in Register 0x008.	0x0	R/W
0x871	DDSM_HOPF_FTW27_3	[7:0]	DDSM_HOPF_FTW27[31:24]		Hopping frequency FTW27. This control is paged by the MAINDAC_PAGE control in Register 0x008.	0x0	R/W
0x872	DDSM_HOPF_FTW28_0	[7:0]	DDSM_HOPF_FTW28[7:0]		Hopping frequency FTW28. This control is paged by the MAINDAC_PAGE control in Register 0x008.	0x0	R/W
0x873	DDSM_HOPF_FTW28_1	[7:0]	DDSM_HOPF_FTW28[15:8]		Hopping frequency FTW28. This control is paged by the MAINDAC_PAGE control in Register 0x008.	0x0	R/W
0x874	DDSM_HOPF_FTW28_2	[7:0]	DDSM_HOPF_FTW28[23:16]		Hopping frequency FTW28. This control is paged by the MAINDAC_PAGE control in Register 0x008.	0x0	R/W
0x875	DDSM_HOPF_FTW28_3	[7:0]	DDSM_HOPF_FTW28[31:24]		Hopping frequency FTW28. This control is paged by the MAINDAC_PAGE control in Register 0x008.	0x0	R/W
0x876	DDSM_HOPF_FTW29_0	[7:0]	DDSM_HOPF_FTW29[7:0]		Hopping frequency FTW29. This control is paged by the MAINDAC_PAGE control in Register 0x008.	0x0	R/W
0x877	DDSM_HOPF_FTW29_1	[7:0]	DDSM_HOPF_FTW29[15:8]		Hopping frequency FTW29. This control is paged by the MAINDAC_PAGE control in Register 0x008.	0x0	R/W

Addr.	Name	Bits	Bit Name	Settings	Description	Reset	Access
0x878	DDSM_HOPF_FTW29_2	[7:0]	DDSM_HOPF_FTW29[23:16]		Hopping frequency FTW29. This control is paged by the MAINDAC_PAGE control in Register 0x008.	0x0	R/W
0x879	DDSM_HOPF_FTW29_3	[7:0]	DDSM_HOPF_FTW29[31:24]		Hopping frequency FTW29. This control is paged by the MAINDAC_PAGE control in Register 0x008.	0x0	R/W
0x87A	DDSM_HOPF_FTW30_0	[7:0]	DDSM_HOPF_FTW30[7:0]		Hopping frequency FTW30. This control is paged by the MAINDAC_PAGE control in Register 0x008.	0x0	R/W
0x87B	DDSM_HOPF_FTW30_1	[7:0]	DDSM_HOPF_FTW30[15:8]		Hopping frequency FTW30. This control is paged by the MAINDAC_PAGE control in Register 0x008.	0x0	R/W
0x87C	DDSM_HOPF_FTW30_2	[7:0]	DDSM_HOPF_FTW30[23:16]		Hopping frequency FTW30. This control is paged by the MAINDAC_PAGE control in Register 0x008.	0x0	R/W
0x87D	DDSM_HOPF_FTW30_3	[7:0]	DDSM_HOPF_FTW30[31:24]		Hopping frequency FTW30. This control is paged by the MAINDAC_PAGE control in Register 0x008.	0x0	R/W
0x87E	DDSM_HOPF_FTW31_0	[7:0]	DDSM_HOPF_FTW31[7:0]		Hopping frequency FTW31. This control is paged by the MAINDAC_PAGE control in Register 0x008.	0x0	R/W
0x87F	DDSM_HOPF_FTW31_1	[7:0]	DDSM_HOPF_FTW31[15:8]		Hopping frequency FTW31. This control is paged by the MAINDAC_PAGE control in Register 0x008.	0x0	R/W
0x880	DDSM_HOPF_FTW31_2	[7:0]	DDSM_HOPF_FTW31[23:16]		Hopping frequency FTW31. This control is paged by the MAINDAC_PAGE control in Register 0x008.	0x0	R/W
0x881	DDSM_HOPF_FTW31_3	[7:0]	DDSM_HOPF_FTW31[31:24]		Hopping frequency FTW31. This control is paged by the MAINDAC_PAGE control in Register 0x008.	0x0	R/W

# OUTLINE DIMENSIONS

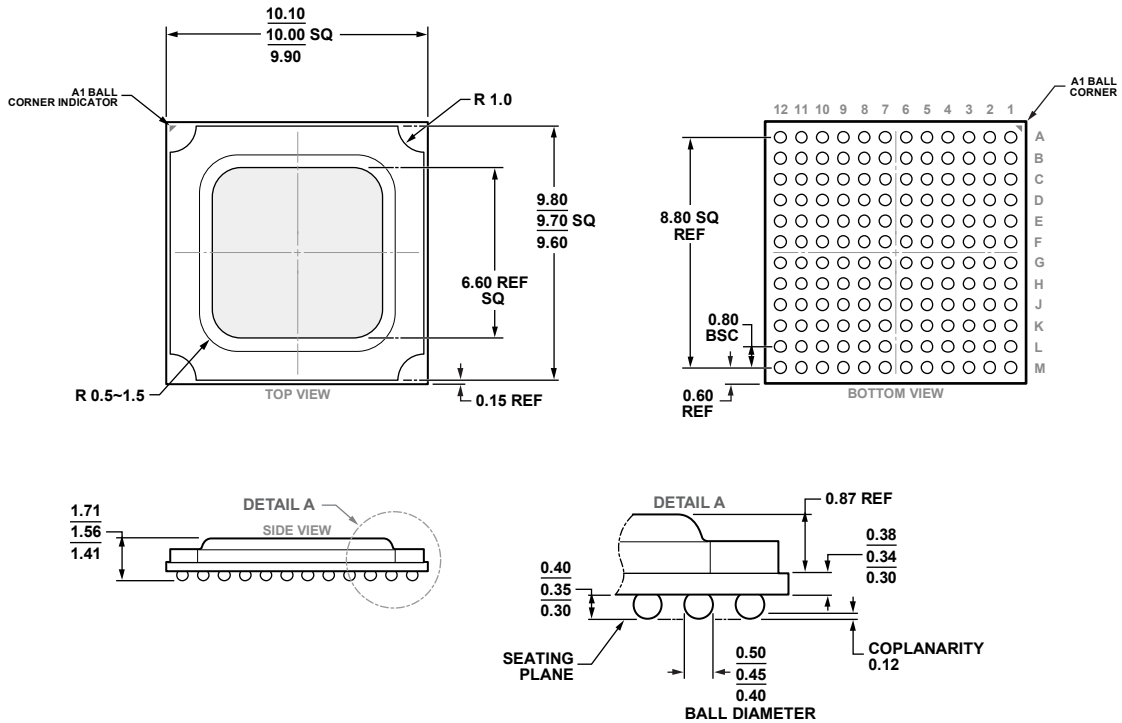

COMPLIANT TO JEDEC STANDARDS MO-275-EEAB-1.

Figure 98. 144-Ball Ball Grid Array, Thermally Enhanced [BGA\_ED] (BP-144-1)

Dimensions shown in millimeters

## ORDERING GUIDE

Model <sup>1</sup>	Temperature Range	Package Description	Package Option
AD9174BBPZ	-40°C to +85°C	144-Ball Ball Grid Array, Thermally Enhanced [BGA_ED]	BP-144-1
AD9174BBPZRL	-40°C to +85°C	144-Ball Ball Grid Array, Thermally Enhanced [BGA_ED]	BP-144-1
AD9174-FMC-EBZ		Evaluation Board	

<sup>1</sup> Z = RoHS Compliant Part.