

Description

The AL17150-10B is a universal high voltage input step-down regulator product family, which provides accurate Constant Voltage (CV) and outstanding dynamic performance without requiring an opto-coupler over line and load regulation. Typical applications are offline low power applications including connected LED lighting power supply for micro-controllers and other IoT applications.

The AL17150-10B integrates a 500V/1A MOSFET that can make it use fewer external components and create a low Bill Of Material (BOM) cost solution. The AL17150-10B can provide up to 300mA output current and lower than 50mW standby power, which is very suitable for IoT connected lighting devices.

The AL17150-10B achieves excellent regulation and high power efficiency. The characteristics of max peak current and driving frequency vary as the load change, which can get excellent efficiency performance at light load and improve the overall average efficiency.

The AL17150-10B has rich protection features to enhance the system safety and reliability. It has Over Temperature Protection, V_{CC} Under Voltage Lock function, Output Short Protection, Over Load Protection and Open Loop Protection.

The AL17150-10B is available in SO-7 package.

Features

- Universal 85 to 265 V_{AC} Input Range
- Internal MOSFET: 500V/1A
- Tight V_{FB} tolerance ±4%
- Maximum 300mA Rated Output Current
- No Load Power Consumption: < 50mW with External Bias
- Frequency Modulation to Suppress EMI
- Under Voltage Lock Out (UVLO)
- Output Short Protection
- Over Load Protection;
- Thermal Shutdown (TSD)
- Fewer Components
- Low Audible Noise Solution
- SO-7 Package
- **Totally Lead-Free & Fully RoHS Compliant (Notes 1 & 2)**
- **Halogen and Antimony Free. "Green" Device (Note 3)**
- **For automotive applications requiring specific change control (i.e. parts qualified to AEC-Q100, PPAP capable, and manufactured in IATF 16949 certified facilities), please [contact us](#) or your local Diodes representative.**
- <https://www.diodes.com/quality/product-definitions/>

Notes: 1. No purposely added lead. Fully EU Directive 2002/95/EC (RoHS), 2011/65/EU (RoHS 2) & 2015/863/EU (RoHS 3) compliant.
 2. See <https://www.diodes.com/quality/lead-free/> for more information about Diodes Incorporated's definitions of Halogen- and Antimony-free, "Green" and Lead-free.
 3. Halogen- and Antimony-free "Green" products are defined as those which contain <900ppm bromine, <900ppm chlorine (<1500ppm total Br + Cl) and <1000ppm antimony compounds.

Pin Assignments

(Top View)

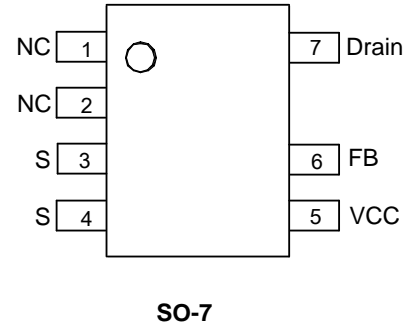

Applications

- IoT Connected Lighting Applications
- Home Appliance Applications
- Industrial Controls
- Standby and Auxiliary

Typical Applications Circuit

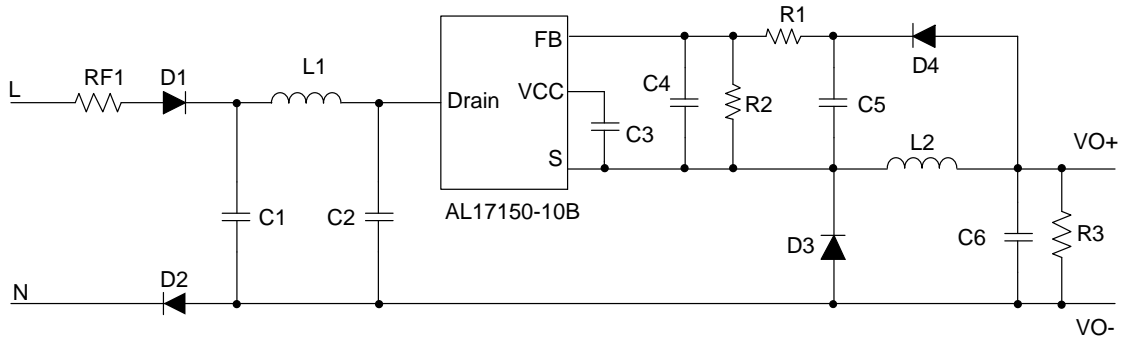

Pin Descriptions

Pin Number	Name	Function
1, 2	N/C	Not Connected.
3, 4	S	Internal Power MOSFET Source. Ground Reference for VCC and FB Pins.
5	VCC	Connection Point of External Bypass Capacitor for Internally Generated Control Circuit Power Supply.
6	FB	Regulator Feedback.
7	Drain	Internal Power MOSFET Drain. High-Voltage Current Source Input.

Functional Block Diagram

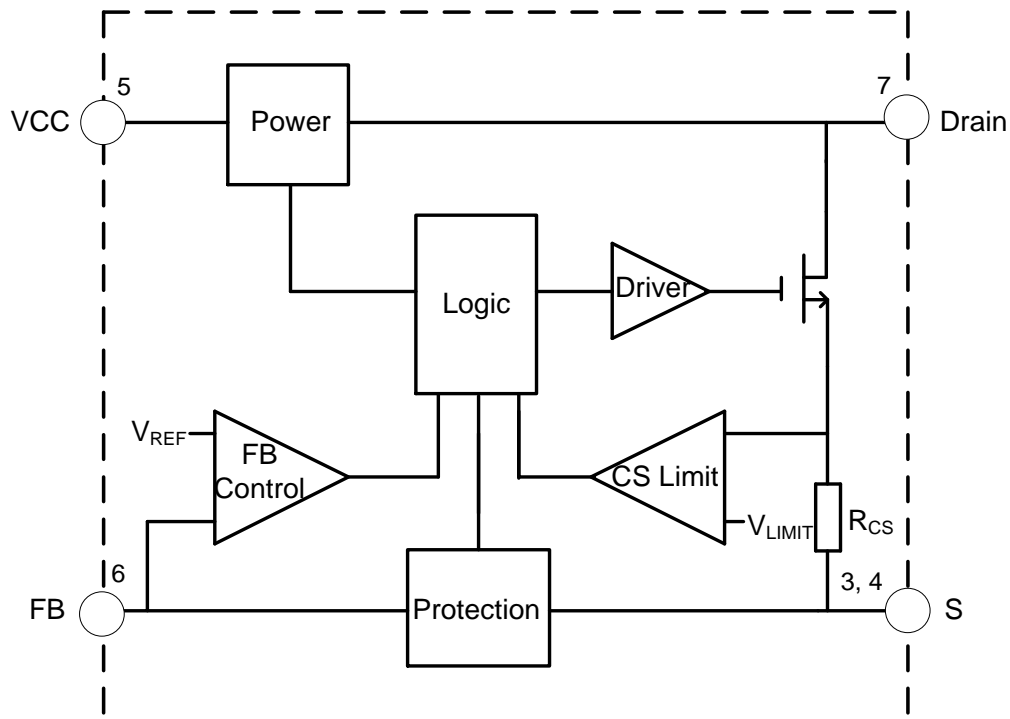

Absolute Maximum Ratings (Note 4)

Symbol	Parameter	Rating	Unit
V _{DSS}	Voltage of Drain to S pin	-0.7 to 500	V
V _{FB}	Voltage of FB to S Pin	-0.7 to 6.5	V
V _{CC}	Operating VCC Voltage	8.9	V
P _D	Continuous Power Dissipation (T _A = +25°C)	1	W
T _J	Operating Junction Temperature	+150	°C
T _{STG}	Storage Temperature	-65 to +150	°C
T _{LEAD}	Lead Temperature (Soldering, 10s)	+300	°C
θ _{JA}	Thermal Resistance (Junction to Ambient)	139	°C/W
θ _{JC}	Thermal Resistance (Junction to Case)	21	°C/W
ESD	ESD (Human Body Model)	4000	V
	ESD (Charge Device Model)	1000	V

Note: 4. Stresses greater than those listed under *Absolute Maximum Ratings* can cause permanent damage to the device. These are stress ratings only, and functional operation of the device at these or any other conditions beyond those indicated under *Recommended Operating Conditions* is not implied. Exposure to *Absolute Maximum Ratings* for extended periods can affect device reliability.

Recommended Operating Conditions

Symbol	Parameter	Min	Max	Unit
V _{CC}	Supply Voltage	8.2	8.8	V
T _A	Ambient Temperature	-40	+125	°C
I _{OUT}	Output Current with 3.3V/5V Output Voltage	—	300	mA

Electrical Characteristics ($V_{CC} = 8.8V$, $T_A = +25^\circ C$, unless otherwise specified.)

Symbol	Parameter	Condition	Min	Typ	Max	Unit
HV Startup Current Source						
I_{HV}	HV Supply Current	$V_{CC} = 7V$; $V_{DRAIN} = 100V$	1.2	3.5	—	mA
I_{LEAK}	Leakage Current of Drain	$V_{CC} = 8.8V$; $V_{DRAIN} = 400V$	—	10	12	μA
V_{CC} Voltage Management						
V_{CC_OFF}	VCC Supply OFF Threshold Voltage	—	8.1	8.5	8.8	V
V_{CC_ON}	VCC Supply ON Threshold Voltage	—	7.8	8.2	8.6	V
—	VCC Supply ON and OFF Hysteresis	—	—	280	—	mV
V_{CC_UVLO}	Minimum Operating Voltage	—	—	6.5	—	V
$V_{CC_RESTART}$	Restart Voltage	—	—	4.5	—	V
I_{CC}	Operating Current	$V_{CC} = 7.5V$, $f_S = 40kHz$, $D = 40\%$	—	350	—	μA
I_{CC_QC}	Quiescent Current with No Switching	—	—	110	200	μA
I_{CC_LATCH}	Latch Off Current	—	—	26	—	μA
Internal MOSFET						
V_{DS}	Breakdown Voltage (Note 5)	—	500	—	—	V
$R_{DS(ON)}$	ON Resistance	—	—	—	12	Ω
Internal Current Sense						
I_{PK_MAX}	Peak Current	—	413	500	600	mA
t_{LEB}	Leading Edge Blanking Time	—	—	250	400	ns
I_{SCP}	SCP Point Current	—	—	800	—	mA
Feedback Input (FB Pin)						
t_{MINOFF}	Minimum off Time	—	10.5	15.5	18.5	μs
V_{FB}	MOSFET Feedback Switch-On Threshold	—	2.4	2.5	2.6	V
V_{FB_OLP}	OLP Feedback Trigger Threshold	—	1.56	1.7	1.84	V
t_{OLP}	OLP Delay Time	$f_S = 37kHz$	—	170	—	ms
V_{OLD}	Open-Loop Detection	—	—	60	—	mV
t_{OLD}	OLD Active Time	$f_S = 15kHz$	—	4.3	—	ms
Thermal Shutdown						
T_{SD}	Thermal Shutdown Threshold	—	+135	+150	+165	$^\circ C$

 Note: 5. The drain-source voltage is 80% of V_{DSS} in the aging condition.

Typical Characteristics (Note 6)

NEW PRODUCT

Feedback Threshold Voltage vs. Ambient Temperature

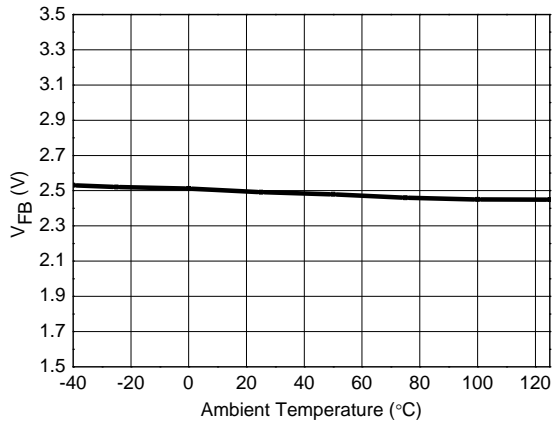

Minimum Operating Voltage vs. Ambient Temperature

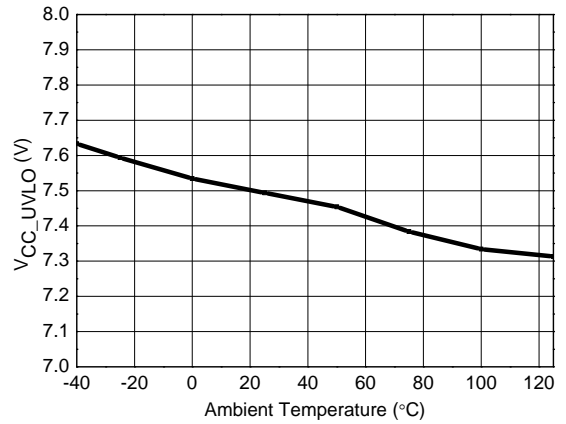

Standby Current vs. Ambient Temperature

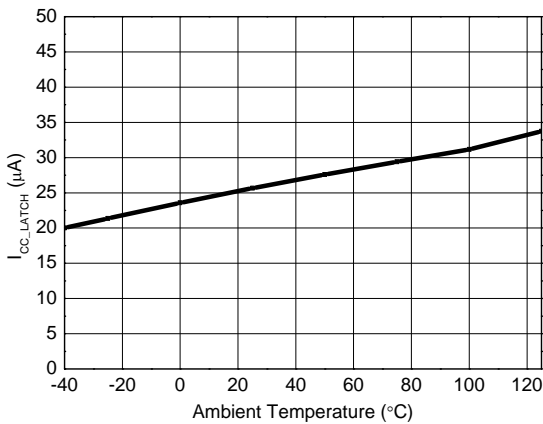

Latch Off Current vs. Ambient Temperature

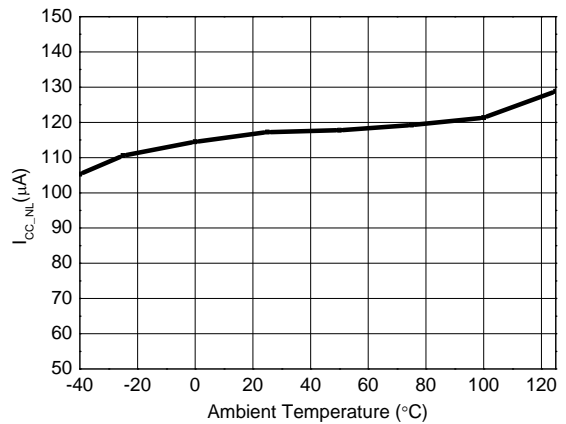

Operating Current vs. Ambient Temperature

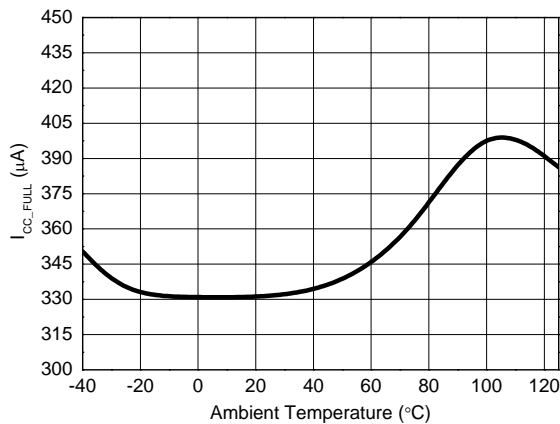

Peak Current vs. Ambient Temperature

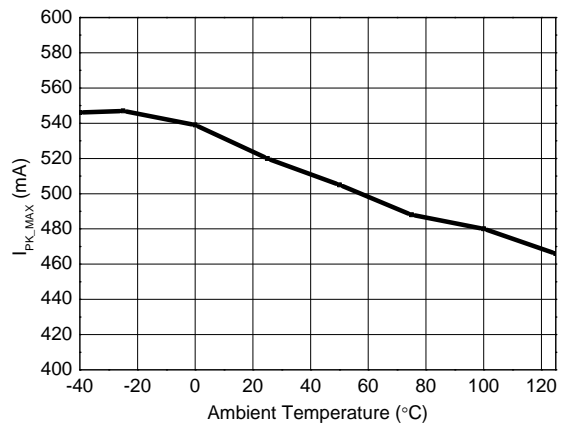

Note: 6. These electrical characteristics are tested under DC condition. The ambient temperature is equal to the junction temperature of the device.

Function Description

Overall Introduction

The AL17150-10B is a universal AC input step down regulator. Max peak current limitation and driving frequency vary as the load change can get excellent efficiency performance at light load and improve the overall efficiency of system. Working with a single winding inductor and integrating 500V/1A MOSFET internal can make it use fewer external components and create a low BOM cost solution. Figure 1 shows a typical application example of a Buck topology power supply.

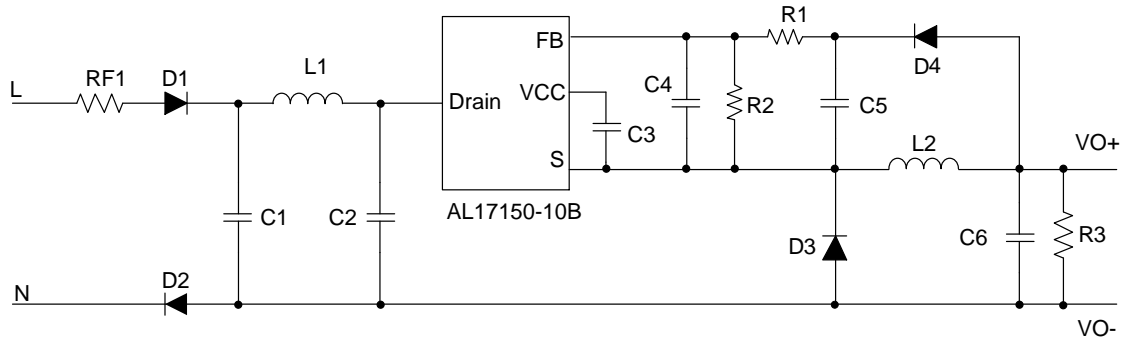

Figure 1. Typical Application Circuit

Converter Operation

Startup and Under Voltage Lock-Out

The IC control voltage V_{CC} is charged by internal high voltage regulator. When the V_{CC} voltage is charged to 8.5V, IC startups and the internal high voltage regulator is turned off; when the V_{CC} voltage drops below 8.2V, the internal high voltage regulator turns on again to charge the external VCC capacitor.

When fault conditions happen, such as some protections like overload faults, short-circuit faults, over temperature faults, and open-loop faults, the AL17150-10B stops switching. Afterwards an internal current source I_{BP_LATCH} discharges the external BP capacitor. The internal high-voltage regulator will not turn on again until the voltage on BP capacitor drops below $V_{BP_RESTART}$ (4.5V). The restart time interval is proportional to the capacitance of external BP capacitor—the larger capacitance of the external BP capacitor, the longer restart time.

The restart time after a fault is about

$$t_{RESTART} = C_{VCC} \times \left(\frac{V_{CC_FAULT} - V_{CC_RESTART}}{I_{CC_LATCH}} + \frac{V_{CC_OFF} - V_{CC_RESTART}}{I_{HV}} \right) \dots\dots\dots (1)$$

Where:

V_{CC_FAULT} is actual voltage value of VCC pin at the time of fault, which is between V_{CC_ON} and V_{CC_OFF} .

Figure 2 shows the typical waveform of V_{CC} .

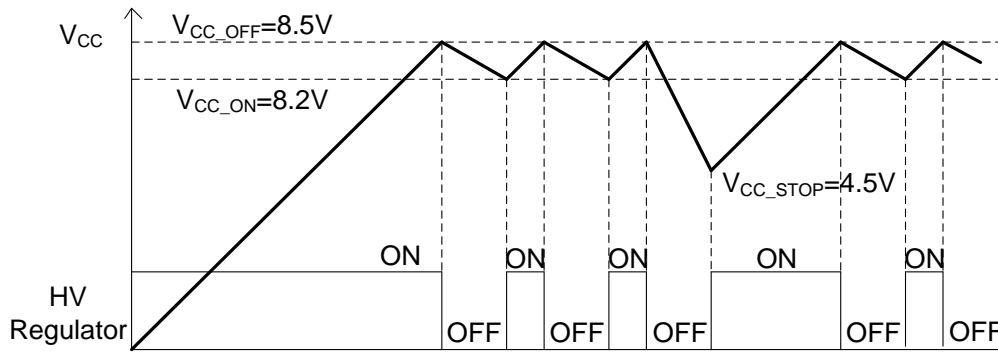

Figure 2. V_{CC} Waveform and Internal HV Regulator ON/OFF Status

Auxiliary VCC Supply

If the output voltage is higher than the voltage of V_{CC_ON} , an auxiliary V_{CC} supply can be implemented to reduce overall power consumption by connecting a resistor (R4) between C2 and C3. A standby power of less than 50mW can be achieved especially in a no-load condition.

Function Description (continued)

Figure 3 shows the low standby power circuit with the auxiliary V_{CC} supply.

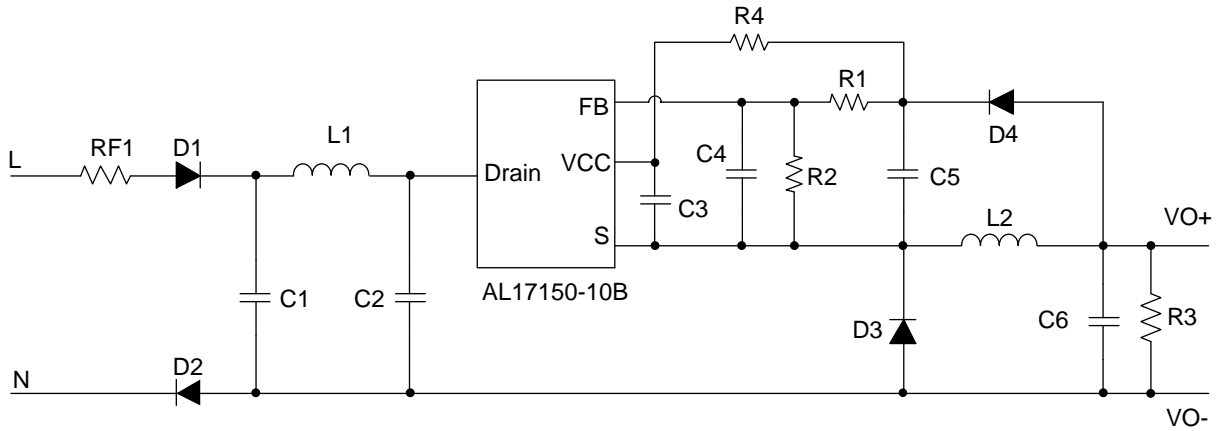

Figure 3. Low Standby Power Circuit with Auxiliary V_{CC} Supply

The value of R₄ can be determined by the following equation:

$$R_4 = \frac{V_o - V_{CC_ON}}{I_{CC_QC}} \dots \dots \dots (2)$$

Constant Voltage Operation

The AL17150-10B is a step down regulator with 500V/1A MOSFET internal. It can be used in Buck circuit as shown in the *Typical Application Circuit*.

In the course of running IC, when the voltage of FB pin is below the reference voltage (2.5V), the internal integrated MOSFET turns ON. The peak current limit and the initial inductance current value altogether with the input voltage determine the ON period time. When the current reaches peak current limit, the internal integrated MOSFET turns OFF. The inductor current charges the sampling capacitor (C₅) and the output capacitor (C₆) via the freewheeling diode D₄ and D₃ respectively. The sampling capacitor voltage is the mapping of the output voltage. The output voltage can be controlled by sampling the voltage of feedback pin which is derived from the voltage of sampling capacitor. In the OFF stage of internal MOSFET, when the inductor current drops below the output current, the sampling capacitor voltage begins to decrease. When the voltage of feedback pin falls below the reference voltage (2.5V), a new switching cycle begins.

Figure 4 shows the detailed operation timing diagrams under Discontinuous Conduction Mode (DCM) and Continuous Conduction Mode (CCM).

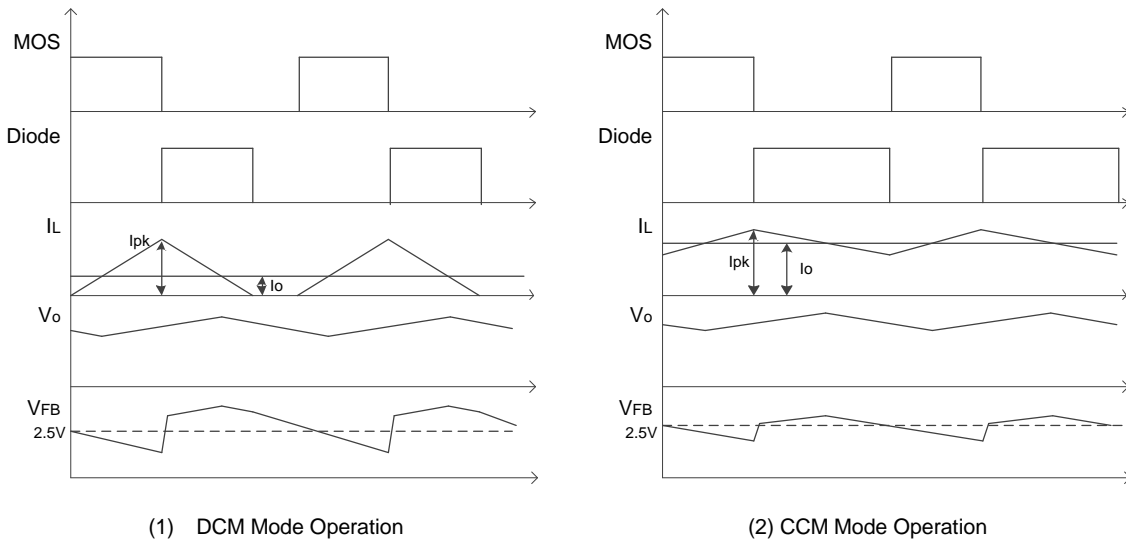

Figure 4. Operation Timing of AL17150-10B

Function Description (continued)

Generally, the output voltage can be described as the following equation:

$$V_O = 2.5 \times (R_1 + R_2) / R_2 \quad \dots\dots\dots (3)$$

Frequency and Peak Current

To maintain high efficiency under different load condition, the AL17150-10B adjusts the switching frequency automatically. The switching frequency can be calculated with Equation 4 for DCM mode operation and Equation 5 for CCM mode operation.

$$f_s = \frac{2(V_{IN}-V_O)}{L \cdot I_{PK}^2} \cdot \frac{I_O V_O}{V_{IN}} \quad \dots\dots\dots (4)$$

$$f_s = \frac{(V_{IN}-V_O)}{2L \cdot (I_{PK}-I_O)} \cdot \frac{V_O}{V_{IN}} \quad \dots\dots\dots (5)$$

In the meantime, the peak current of the inductor (I_{PK}) is determined by the following equation:

$$I_{PK} = 500mA - (4mA/\mu s) \times (t_{OFF} - 15.5\mu s) \quad \dots\dots\dots (6)$$

In the Equation 6, t_{OFF} is internal MOSFET OFF time of the IC, and 500mA is peak current limit and 15.5 μ s is the minimum t_{OFF} value.

As the load decreases, the switching frequency decreases and the MOSFET OFF time t_{OFF} increases, leading to the decrease of peak current. In no load condition, in which only a dummy load is retained, the frequency and the peak current are both minimized. This helps to reduce the no load power consumption.

Startup Control

The AL17150-10B implements a minimum OFF time control. In normal condition, the minimum OFF time limit is 15.5 μ s.

In the startup process, the output voltage is not established and more demagnetizing time is needed. Therefore, the soft start technique is adopted. During the startup process, the minimum MOSFET OFF time varies with three stages, and it gradually drops from 60 μ s to 30 μ s, and then to 15.5 μ s. Each stage contains 128 switching cycles and the startup process will end if the desired output voltage is reached.

EA Compensation

To improve load regulation and load transient performance, the AL17150-10B is designed with an Error Amplifier (EA) compensation function.

The compensation is related to the load condition. With an increasing load, the compensation value increases and the reference voltage of the internal feedback comparator is slightly pulled down. A faster change in the load will lead to a greater compensation step. The output voltage will be regulated back to the desired voltage. This compensation will precisely maintain the output voltage.

Leading-Edge Blanking

A narrow spike on the leading edge of the current waveform can usually be observed when the power MOSFET is turned on. A 250ns leading-edge blank is built-in to prevent the false-triggering caused by the turn-on spike. During this period, the current limit comparator is disabled and the gate driver cannot be switched off.

Protection

Short-Circuit Protection (SCP)

The AL17150-10B will shut down when the peak current exceeds the short-circuit protection threshold (800mA). The AL17150-10B will resume operation when the fault is removed.

Over Load Protection (OLP)

With the increase of load, the peak current and the switching frequency increase. When the peak current reaches the maximum limitation, and the OFF time is the minimum OFF time, the output voltage drops if the load continues to increase. Similarly, the FB voltage decreases as the output voltage drops. When FB voltage drops below OLP threshold V_{FB_OLP} (1.7V), the internal timer of overload starts to count. Once the overload duration lasts more than the OLP delay time t_{OLP} (170ms), the OLP occurs.

The time delay setting of OLP should avoid triggering OLP when the system starts up or enters a load transition phase. Therefore it requires that the system startup time must be less than t_{OLP} . The 170ms time delay of t_{OLP} is calculated under the condition of 36kHz operating frequency. The different operating frequency corresponds to different time delay, the time delay calculation under different operating frequency (f_s) as follows:

$$t_{DELAY} = 170ms \times \frac{36kHz}{f_s} \quad \dots\dots\dots (7)$$

Function Description (continued)

Open Loop Detection

When the V_{FB} drops below 60mV, the AL17150-10B will stop working and begin a re-start cycle. The open loop detection is blanked for 64 switching cycles during start-up stage.

Thermal Shutdown (TSD)

The AL17150-10B integrates an internal thermal shutdown protection function. If the IC junction temperature rises above T_{JSTOP} (typical value: +150°C), the Thermal Shutdown (TSD) protection is triggered and the internal MOSFET stops switching. To recover the switching of internal MOSFET, the IC junction temperature has to fall by a hysteresis of +30°C below the T_{JSTOP} . During TSD protection, V_{CC} drops to $V_{CC_RESTART}$ (typical value 4.5V), and then the internal high voltage regulator recharges V_{CC} .

Application and Implementation

The AL17150-10B is a universal high voltage step-down regulator. Figure 1 shows a typical application for reference. The application can be used in a wide variety of home appliances and industrial control devices, or any other application where mains isolation is not required.

Input Stage

The input stage consists of RF1, D1, D2, C1, C2 and L1, Resistor RF1 is a fusible resistor. RF1 limits the inrush current, and also provides protection in case any component failure causes a short circuit. Value for its resistance is generally selected from 4.7Ω to 15Ω. A half-wave rectifier is implemented with the diode D1. It is a general purpose 1A/1000V diode. D2 is added for improving common-mode conducted EMI noise performance and can be removed if not needed. Components C1, L1, C2 form a Pi EMI filter; Capacitors C1 and C2 also act as storage capacitors for the high-voltage input DC voltage.

When using the half-wave rectifier, set the input capacitor 3μF/W for the universal input condition. When using the full-wave rectifier, choose a smaller capacitor. To avoid thermal shutdown, capacitance selection must avoid the minimum DC voltage below 70V. And if passing surge test is needed for the converter, adjusting input capacitance can help to meet different surge test requirements.

V_{CC} Capacitor

The V_{CC} capacitor (C3) acts as the storage capacitor for the IC internal power supply. A typical selection is a 2.2μF/10V SMD ceramic capacitor.

Inductor

In Buck converter, the inductor peak to peak current ripple can be obtained with Equation 8 for DCM mode operation and with Equation 9 for CCM mode operation.

$$\Delta I_L = I_{PK} \dots\dots\dots (8)$$

$$\Delta I_L = 2 \times (I_{PK} - I_{OUT}) \dots\dots\dots (9)$$

The internal MOSFET turn-on time (t_{ON}) can be given by Equation 10 and it is determine by the peak current limit and the inductor.

$$t_{ON} = \frac{L \cdot \Delta I_L}{V_{IN} - V_O} \dots\dots\dots (10)$$

To guarantee normal operation, t_{ON} must be bigger than t_{LEB} with margin.

The Buck converter reaches maximum power when the off-time equals the minimum off time (t_{MINOFF}). Thus the maximum output power can be calculated with Equation 11 for DCM mode operation and with Equation 12 for CCM mode operation.

$$P_{OMAX} = \frac{1}{2} L \cdot I_{PK}^2 \cdot \frac{1}{t_{ON} + t_{MINOFF}} \approx \frac{1}{2} L \cdot I_{PK}^2 \cdot \frac{1}{t_{MINOFF}} \dots\dots\dots (11)$$

$$P_{OMAX} = V_O (I_{PK} - \frac{V_O t_{MINOFF}}{2L}) \dots\dots\dots (12)$$

Since the on-time is generally far smaller than the off-time, the approximation in Equation 8 can be reasonable for estimation.

To design an inductor, the desired maximum output power is given according to the output specification. The desired peak current is also estimated, no more than 500mA. Since t_{MINOFF} is 15.5μs, a minimum inductance can be calculated with Equation 8. The inductance should be checked with the above equations, and it should be adjusted to ensure that the on-time limitation is satisfied and the desired peak current under full load is met. Some inductance margin is also needed for tolerance.

With the inductance and its peak current value, a standard off-the-shelf inductor can be used to reduce cost.

Function Description (continued)

Freewheeling Diode

The maximum reverse voltage that the diode would experience during normal operation is given by the following equation.

$$V_{D-MAX} = \sqrt{2} \times V_{INAC-MAX} \dots \dots \dots (13)$$

For a universal AC input application, the 265V_{AC}, thus V_{D-MAX} value is 375V. Considering a margin of 20%, a 600V diode is a general selection.

A fast recovery diode is required for the Buck application. And the reverse recovery time should be kept less than 100ns.

Output Capacitor

The output capacitor maintains the DC output voltage, and the value impacts the output ripple. The output voltage ripple can be estimated with Equation 14 for DCM mode operation and Equation 15 for CCM mode operation.

$$V_{OUT_RIPPLE} = \frac{I_{OUT}}{f_s C_{OUT}} \cdot \left(\frac{I_{PK} - I_{OUT}}{I_{PK}} \right) + I_{PK} \cdot R_{ESR} \dots \dots \dots (14)$$

$$V_{OUT_RIPPLE} = \frac{\Delta I_L}{f_s C_{OUT}} + \Delta I_L \cdot R_{ESR} \dots \dots \dots (15)$$

Where f_s is the switching frequency, and R_{ESR} is ESR of output capacitor. For a typical application, the capacitor value can range from 47μF to hundreds of μF. If the total ripple is higher than the requirement, increasing the capacitance and reducing the ESR can be helpful.

Dummy Load

The output requires a dummy load (R3) to maintain the load regulation under no-load condition. This can ensure sufficient inductor energy to charge the sample-and-hold capacitor to detect the output voltage. Most applications can use a 3mA dummy load, and the dummy load can be adjusted according to the regulation. Increasing the dummy load adversely affects the efficiency and no-load consumption.

Feedback Path

R1 and R2 form a resistor divider that determines the output voltage. The values of R1 and R2 should be set to maintain the FB voltage at 2.5V. The typical value for R2 is between 5kΩ to 10kΩ and precision of R1 and R2 must be 1%.

$$V_{OUT} = V_{FB} \cdot \frac{R_1 + R_2}{R_2} + V_{D3} - V_{D2} \approx V_{FB} \cdot \frac{R_1 + R_2}{R_2} \dots \dots \dots (16)$$

For low output voltage application, the difference caused by D3 and D4 cannot be neglected and R1 should be set larger to compensate the difference. Since the diode forward voltage is positively related with the current flows through it and the current through D3 is much higher than D4, V_{D3} is higher than V_{D4}.

The feedback capacitor provides a sample and hold function and the capacitance selection should follow the Equation 17 as below.

$$\frac{V_{OUT}}{2(R_1 + R_2)} \cdot \frac{C_6}{I_{OUT}} < C_5 < \frac{V_{OUT}}{(R_1 + R_2)} \cdot \frac{C_6}{I_{OUT}} \dots \dots \dots (17)$$

The capacitor C5 is discharged with a time constant that is $\tau_{FB} = C_5 \cdot (R_1 + R_2)$ and $\tau_{out} = C_6 \cdot V_{OUT} / I_{OUT}$ can be regarded as the load time constant. If τ_{FB} is larger than τ_{out} , voltage on C5 could be larger than V_{OUT} when sampling, leading to wrong sampling of V_{OUT} and wrong regulation. And if τ_{FB} is too small, voltage on FB pin would drop to 1.7V before the next MOSFET OFF time come and thus mis-trigger Over Load Protection(OLP). Therefore, an appropriate value of C5 is important.

Layout Guidelines

The PCB layout is important to achieve reliable operation, good EMI, and thermal performance. Follow these guidelines to optimize performance.

- Minimize the loop area formed by the input capacitor, IC part, freewheeling diode, inductor and output capacitor.
- The copper area of the FB signal should be minimized to reduce coupling to feedback path.
- A several-hundred pF capacitor should be added between the FB and S pins, and be placed as close as to the FB pin as possible.
- Place the power inductor far away from the input filter.
- Connect the exposed pad with the Drain pin to a large copper area to improve thermal performance.

Ordering Information

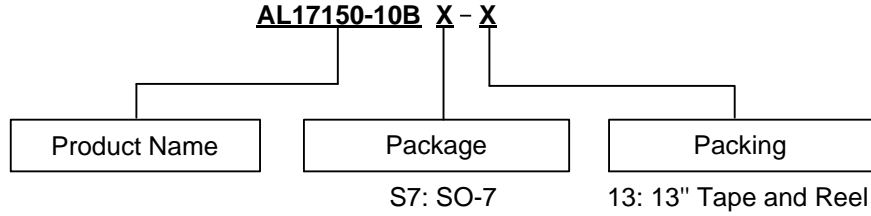

Part Number	Package Code	Package	13" Tape and Reel	
			Quantity	Part Number Suffix
AL17150-10BS7-13	S7	SO-7	4000/Tape & Reel	-13

Marking Information

Package Type: SO-7

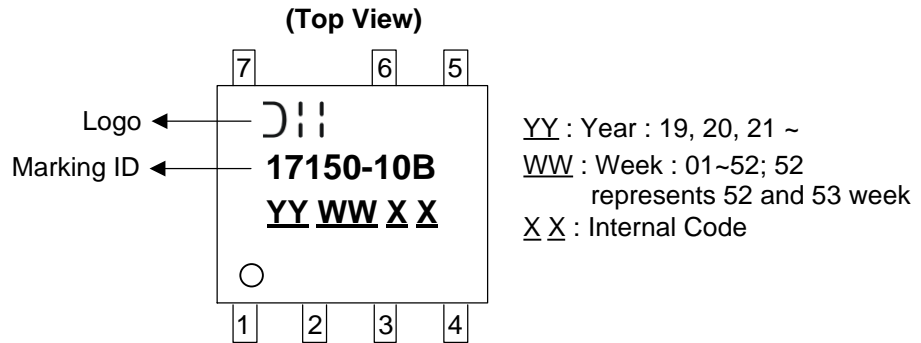

Package Outline Dimensions (All dimensions in mm(inch).)

Please see <http://www.diodes.com/package-outlines.html> for the latest version.

Package Type: SO-7

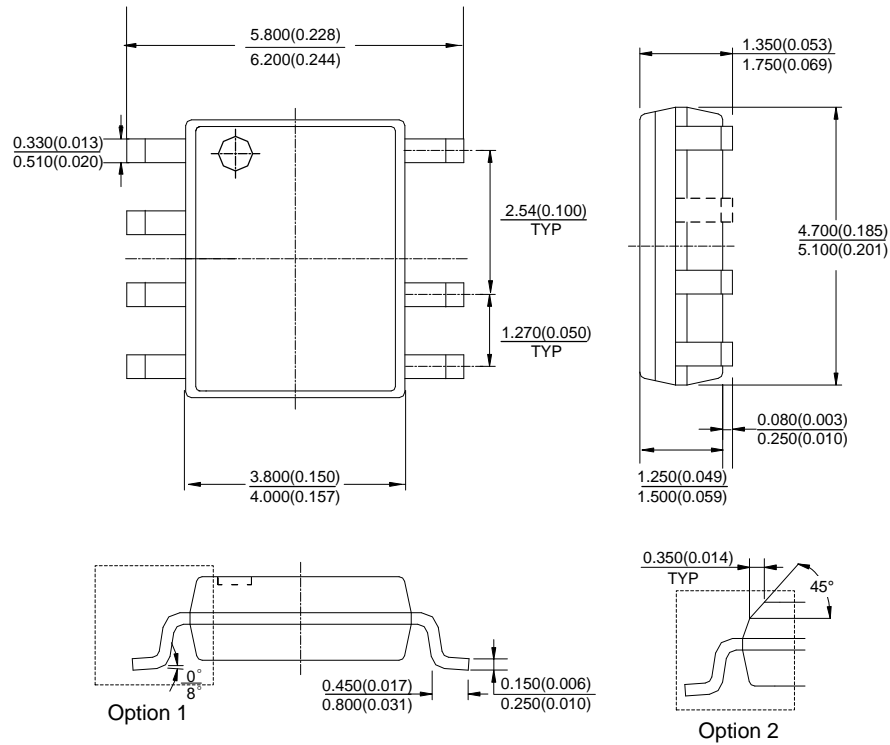

Note: Eject hole, oriented hole and mold mark is optional.

Suggested Pad Layout

Please see <http://www.diodes.com/package-outlines.html> for the latest version.

Package Type: SO-7

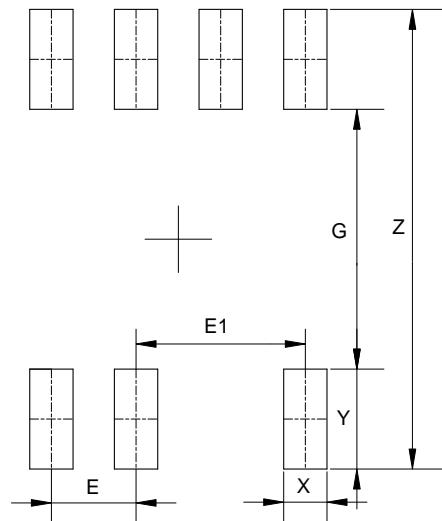

Dimensions	Z (mm)/(inch)	G (mm)/(inch)	X (mm)/(inch)	Y (mm)/(inch)	E (mm)/(inch)	E1 (mm)/(inch)
Value	6.900/0.272	3.900/0.154	0.650/0.026	1.500/0.059	1.270/0.050	2.540/0.100

IMPORTANT NOTICE

DIODES INCORPORATED MAKES NO WARRANTY OF ANY KIND, EXPRESS OR IMPLIED, WITH REGARDS TO THIS DOCUMENT, INCLUDING, BUT NOT LIMITED TO, THE IMPLIED WARRANTIES OF MERCHANTABILITY AND FITNESS FOR A PARTICULAR PURPOSE (AND THEIR EQUIVALENTS UNDER THE LAWS OF ANY JURISDICTION).

Diodes Incorporated and its subsidiaries reserve the right to make modifications, enhancements, improvements, corrections or other changes without further notice to this document and any product described herein. Diodes Incorporated does not assume any liability arising out of the application or use of this document or any product described herein; neither does Diodes Incorporated convey any license under its patent or trademark rights, nor the rights of others. Any Customer or user of this document or products described herein in such applications shall assume all risks of such use and will agree to hold Diodes Incorporated and all the companies whose products are represented on Diodes Incorporated website, harmless against all damages.

Diodes Incorporated does not warrant or accept any liability whatsoever in respect of any products purchased through unauthorized sales channel. Should Customers purchase or use Diodes Incorporated products for any unintended or unauthorized application, Customers shall indemnify and hold Diodes Incorporated and its representatives harmless against all claims, damages, expenses, and attorney fees arising out of, directly or indirectly, any claim of personal injury or death associated with such unintended or unauthorized application.

Products described herein may be covered by one or more United States, international or foreign patents pending. Product names and markings noted herein may also be covered by one or more United States, international or foreign trademarks.

This document is written in English but may be translated into multiple languages for reference. Only the English version of this document is the final and determinative format released by Diodes Incorporated.

LIFE SUPPORT

Diodes Incorporated products are specifically not authorized for use as critical components in life support devices or systems without the express written approval of the Chief Executive Officer of Diodes Incorporated. As used herein:

A. Life support devices or systems are devices or systems which:

1. are intended to implant into the body, or
2. support or sustain life and whose failure to perform when properly used in accordance with instructions for use provided in the labeling can be reasonably expected to result in significant injury to the user.

B. A critical component is any component in a life support device or system whose failure to perform can be reasonably expected to cause the failure of the life support device or to affect its safety or effectiveness.

Customers represent that they have all necessary expertise in the safety and regulatory ramifications of their life support devices or systems, and acknowledge and agree that they are solely responsible for all legal, regulatory and safety-related requirements concerning their products and any use of Diodes Incorporated products in such safety-critical, life support devices or systems, notwithstanding any devices- or systems-related information or support that may be provided by Diodes Incorporated. Further, Customers must fully indemnify Diodes Incorporated and its representatives against any damages arising out of the use of Diodes Incorporated products in such safety-critical, life support devices or systems.

Copyright © 2019, Diodes Incorporated

www.diodes.com

Mouser Electronics

Authorized Distributor

Click to View Pricing, Inventory, Delivery & Lifecycle Information:

[Diodes Incorporated:](#)

[AL17150-10BS7-13](#)