

Arm[®] Cortex[®]-M0+ 32-bit MCU, up to 512KB Flash, 144KB RAM, 6x USART, timers, ADC, DAC, comm. I/Fs, 1.7-3.6 V

Datasheet - production data

Features

- Includes ST state-of-the-art patented technology
- Core: Arm[®] 32-bit Cortex[®]-M0+ CPU, frequency up to 64 MHz
- -40°C to 85°C/105°C/125°C operating temperature
- Memories
 - Up to 512 Kbytes of flash memory with protection and securable area, two banks, read-while-write support
 - 144 Kbytes of SRAM (128 Kbytes with HW parity check)
- CRC calculation unit
- Reset and power management
 - Voltage range: 1.7 V to 3.6 V
 - Separate I/O supply pin (1.65 V to 3.6 V)
 - Power-on/Power-down reset (POR/PDR)
 - Programmable Brownout reset (BOR)
 - Programmable voltage detector (PVD)
 - Low-power modes: Sleep, Stop, Standby, Shutdown
 - V_{BAT} supply for RTC and backup registers
- Clock management
 - 4 to 48 MHz crystal oscillator
 - 32 kHz crystal oscillator with calibration
 - Internal 16 MHz RC with PLL option (±1 %)
 - Internal 48 MHz RC oscillator
 - Internal 32 kHz RC oscillator (±5 %)
- Up to 94 fast I/Os
 - All mappable on external interrupt vectors
 - Multiple 5 V-tolerant I/Os
- 12-channel DMA controller with flexible mapping
- 12-bit, 0.4 μs ADC (up to 16 ext. channels)
 - Up to 16-bit with hardware oversampling
 - Conversion range: 0 to 3.6V
- Two 12-bit DACs, low-power sample-and-hold
- Three fast low-power analog comparators, with programmable input and output, rail-to-rail
- 15 timers (two 128 MHz capable): 16-bit for advanced motor control, one 32-bit and six 16-bit general-purpose, two basic 16-bit, two low-power 16-bit, two watchdogs, SysTick timer
- Calendar RTC with alarm and periodic wakeup from Stop/Standby/Shutdown

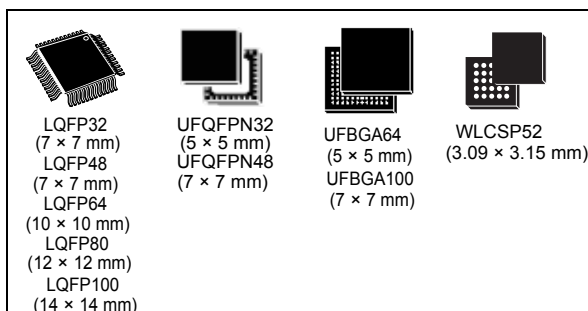

- Communication interfaces
 - Three I²C-bus interfaces supporting Fast-mode Plus (1 Mbit/s) with extra current sink, two supporting SMBus/PMBus and wakeup from Stop mode
 - Six USARTs with master/slave synchronous SPI; three supporting ISO7816 interface, LIN, IrDA capability, auto baud rate detection and wakeup feature
 - Two low-power UARTs
 - Three SPIs (32 Mbit/s) with 4- to 16-bit programmable bitframe, two multiplexed with I²S interface; six extra SPIs through USARTs
 - HDMI CEC interface, wakeup on header
- USB 2.0 FS device (crystal-less) and host controller
- USB Type-C™ Power Delivery controller
- Two FDCAN controllers
- Development support: serial wire debug (SWD)
- 96-bit unique ID
- All packages ECOPACK 2 compliant

Table 1. Device summary

Reference	Part number
STM32G0B1xB	STM32G0B1CB, STM32G0B1KB, STM32G0B1MB, STM32G0B1RB, STM32G0B1VB
STM32G0B1xC	STM32G0B1CC, STM32G0B1KC, STM32G0B1MC, STM32G0B1RC, STM32G0B1VC
STM32G0B1xE	STM32G0B1CE, STM32G0B1KE, STM32G0B1ME, STM32G0B1NE, STM32G0B1RE, STM32G0B1VE

Contents

1	Introduction	10
2	Description	11
3	Functional overview	14
3.1	Arm® Cortex®-M0+ core with MPU	14
3.2	Memory protection unit	14
3.3	Embedded flash memory	14
3.3.1	Securable area	15
3.4	Embedded SRAM	16
3.5	Boot modes	16
3.6	Cyclic redundancy check calculation unit (CRC)	16
3.7	Power supply management	17
3.7.1	Power supply schemes	17
3.7.2	Power supply supervisor	18
3.7.3	Voltage regulator	18
3.7.4	Low-power modes	19
3.7.5	Reset mode	20
3.7.6	VBAT operation	20
3.8	Interconnect of peripherals	20
3.9	Clocks and startup	22
3.10	General-purpose inputs/outputs (GPIOs)	23
3.11	Direct memory access controller (DMA)	23
3.12	DMA request multiplexer (DMAMUX)	23
3.13	Interrupts and events	24
3.13.1	Nested vectored interrupt controller (NVIC)	24
3.13.2	Extended interrupt/event controller (EXTI)	24
3.14	Analog-to-digital converter (ADC)	25
3.14.1	Temperature sensor	25
3.14.2	Internal voltage reference (V_{REFINT})	26
3.14.3	V_{BAT} battery voltage monitoring	26
3.15	Digital-to-analog converter (DAC)	26
3.16	Voltage reference buffer (VREFBUF)	27

3.17	Comparators (COMP)	27
3.18	Timers and watchdogs	27
3.18.1	Advanced-control timer (TIM1)	28
3.18.2	General-purpose timers (TIM2, 3, 4, 14, 15, 16, 17)	29
3.18.3	Basic timers (TIM6 and TIM7)	29
3.18.4	Low-power timers (LPTIM1 and LPTIM2)	29
3.18.5	Independent watchdog (IWDG)	30
3.18.6	System window watchdog (WWDG)	30
3.18.7	SysTick timer	30
3.19	Real-time clock (RTC), tamper (TAMP) and backup registers	30
3.20	Inter-integrated circuit interface (I ² C)	31
3.21	Universal synchronous/asynchronous receiver transmitter (USART) ...	32
3.22	Low-power universal asynchronous receiver transmitter (LPUART) ...	33
3.23	Serial peripheral interface (SPI)	34
3.24	Universal serial bus full-speed host/device interface (USB)	34
3.25	USB Type-C Power Delivery controller	35
3.26	Controller area network (FDCAN)	35
3.27	Development support	35
3.27.1	Serial wire debug port (SW-DP)	35
4	Pinouts, pin description and alternate functions	36
5	Electrical characteristics	64
5.1	Parameter conditions	64
5.1.1	Minimum and maximum values	64
5.1.2	Typical values	64
5.1.3	Typical curves	64
5.1.4	Loading capacitor	64
5.1.5	Pin input voltage	64
5.1.6	Power supply scheme	65
5.1.7	Current consumption measurement	66
5.2	Absolute maximum ratings	66
5.3	Operating conditions	67
5.3.1	General operating conditions	67
5.3.2	Operating conditions at power-up / power-down	68
5.3.3	Embedded reset and power control block characteristics	68

5.3.4	Embedded voltage reference	70
5.3.5	Supply current characteristics	71
5.3.6	Wakeup time from low-power modes and voltage scaling transition times	80
5.3.7	External clock source characteristics	81
5.3.8	Internal clock source characteristics	86
5.3.9	PLL characteristics	88
5.3.10	Flash memory characteristics	89
5.3.11	EMC characteristics	90
5.3.12	Electrical sensitivity characteristics	91
5.3.13	I/O current injection characteristics	92
5.3.14	I/O port characteristics	93
5.3.15	NRST input characteristics	98
5.3.16	Extended interrupt and event controller input (EXTI) characteristics . . .	99
5.3.17	Analog switch booster	100
5.3.18	Analog-to-digital converter characteristics	100
5.3.19	Digital-to-analog converter characteristics	107
5.3.20	Voltage reference buffer characteristics	111
5.3.21	Comparator characteristics	112
5.3.22	Temperature sensor characteristics	113
5.3.23	V _{BAT} monitoring characteristics	113
5.3.24	Timer characteristics	114
5.3.25	Characteristics of communication interfaces	115
6	Package information	125
6.1	Device marking	125
6.2	LQFP32 package information (5V)	126
6.3	UFQFPN32 package information (A0B8)	130
6.4	LQFP48 package information (5B)	134
6.5	UFQFPN48 package information (A0B9)	137
6.6	WLCSP52 package information (B0BG)	139
6.7	LQFP64 package information (5W)	143
6.8	UFBGA64 package information (A019)	146
6.9	LQFP80 package information (9X)	149
6.10	LQFP100 package information (1L)	152
6.11	UFBGA100 package information (A0C2)	155

6.12	Thermal characteristics	158
6.12.1	Reference document	159
6.12.2	Selecting the product temperature range	159
7	Ordering information	161
8	Important security notice	162
9	Revision history	163

List of tables

Table 1.	Device summary	1
Table 2.	Features and peripheral counts	12
Table 3.	Access status versus readout protection level and execution modes.	15
Table 4.	Interconnect of peripherals	21
Table 5.	Temperature sensor calibration values.	26
Table 6.	Internal voltage reference calibration values	26
Table 7.	Timer feature comparison.	28
Table 8.	I ² C implementation	32
Table 9.	USART implementation	33
Table 10.	SPI/I2S implementation	34
Table 11.	Terms and symbols used in <i>Pin assignment and description</i> table	46
Table 12.	Pin assignment and description	47
Table 13.	Port A alternate function mapping (AF0 to AF7).	56
Table 14.	Port A alternate function mapping (AF8 to AF15).	57
Table 15.	Port B alternate function mapping (AF0 to AF7).	58
Table 16.	Port B alternate function mapping (AF8 to AF15).	59
Table 17.	Port C alternate function mapping	60
Table 18.	Port D alternate function mapping	61
Table 19.	Port E alternate function mapping	62
Table 20.	Port F alternate function mapping.	63
Table 21.	Voltage characteristics	66
Table 22.	Current characteristics	66
Table 23.	Thermal characteristics.	67
Table 24.	General operating conditions	67
Table 25.	Operating conditions at power-up / power-down	68
Table 26.	Embedded reset and power control block characteristics.	68
Table 27.	Embedded internal voltage reference.	70
Table 28.	Current consumption in Run and Low-power run modes at different die temperatures	72
Table 29.	Typical current consumption in Run and Low-power run modes, depending on code executed	73
Table 30.	Current consumption in Sleep and Low-power sleep modes	74
Table 31.	Current consumption in Stop 0 mode	74
Table 32.	Current consumption in Stop 1 mode	75
Table 33.	Current consumption in Standby mode	75
Table 34.	Current consumption in Shutdown mode	76
Table 35.	Current consumption in VBAT mode	76
Table 36.	Current consumption of peripherals	78
Table 37.	Low-power mode wakeup times	80
Table 38.	Regulator mode transition times	81
Table 39.	Wakeup time using LPUART	81
Table 40.	High-speed external user clock characteristics.	81
Table 41.	Low-speed external user clock characteristics	82
Table 42.	HSE oscillator characteristics	83
Table 43.	LSE oscillator characteristics (f _{LSE} = 32.768 kHz)	85
Table 44.	HSI16 oscillator characteristics.	86
Table 45.	HSI48 oscillator characteristics.	87
Table 46.	LSI oscillator characteristics	88

Table 47.	PLL characteristics	88
Table 48.	Flash memory characteristics	89
Table 49.	Flash memory endurance and data retention	89
Table 50.	EMS characteristics	90
Table 51.	EMI characteristics	91
Table 52.	ESD absolute maximum ratings	91
Table 53.	Electrical sensitivity	92
Table 54.	I/O current injection susceptibility	92
Table 55.	I/O static characteristics	93
Table 56.	Input characteristics of FT_e I/Os	95
Table 57.	Output voltage characteristics	96
Table 58.	Non-FT_c I/O output timing characteristics	97
Table 59.	FT_c I/O output timing characteristics	98
Table 60.	NRST pin characteristics	98
Table 61.	EXTI input characteristics	99
Table 62.	Analog switch booster characteristics	100
Table 63.	ADC characteristics	100
Table 64.	Maximum ADC R_{AIN}	102
Table 65.	ADC accuracy	103
Table 66.	DAC characteristics	107
Table 67.	DAC accuracy	109
Table 68.	VREFBUF characteristics	111
Table 69.	COMP characteristics	112
Table 70.	TS characteristics	113
Table 71.	V_{BAT} monitoring characteristics	113
Table 72.	V_{BAT} charging characteristics	114
Table 73.	TIMx characteristics	114
Table 74.	IWDG min/max timeout period at 32 kHz LSI clock	115
Table 75.	Minimum I2CCLK frequency	115
Table 76.	I2C analog filter characteristics	116
Table 77.	SPI characteristics	116
Table 78.	I ² S characteristics	119
Table 79.	USART characteristics in SPI mode	121
Table 80.	USB FS electrical characteristics	123
Table 81.	UCPD operating conditions	124
Table 82.	LQFP32 - Mechanical data	127
Table 83.	UFQFPN32 - Mechanical data	131
Table 84.	Tolerance of form and position	131
Table 85.	LQFP48 - Mechanical data	135
Table 86.	UFQFPN48 - Mechanical data	138
Table 87.	WLCSP52 - Mechanical data	140
Table 88.	WLCSP52 - Tolerance of form and position	140
Table 89.	WLCSP52 - Example of PCB design rules	141
Table 90.	LQFP64 - Mechanical data	144
Table 91.	UFBGA64 - Mechanical data	147
Table 92.	UFBGA64 - Example of PCB design rules (0.5 mm pitch BGA)	148
Table 93.	LQFP80 - Mechanical data	150
Table 94.	LQFP100 - Mechanical data	153
Table 95.	UFBGA100 - Mechanical data	156
Table 96.	UFBGA100 - Example of PCB design rules (0.5 mm pitch BGA)	157
Table 97.	Package thermal characteristics	158
Table 98.	Document revision history	163

List of figures

Figure 1.	Block diagram	13
Figure 2.	Power supply overview	18
Figure 3.	STM32G0B1KxT LQFP32 pinout	36
Figure 4.	STM32G0B1KxU UFQFPN32 pinout	37
Figure 5.	STM32G0B1CxT LQFP48 pinout	38
Figure 6.	STM32G0B1CxU UFQFPN48 pinout	39
Figure 7.	STM32G0B1NxY WLCSP52 ballout	40
Figure 8.	STM32G0B1RxT LQFP64 pinout	41
Figure 9.	STM32G0B1RxI UFBGA64 ballout	42
Figure 10.	STM32G0B1MxT LQFP80 pinout	43
Figure 11.	STM32G0B1VxT LQFP100 pinout	44
Figure 12.	STM32G0B1VxI UFBGA100 ballout	45
Figure 13.	Pin loading conditions	64
Figure 14.	Pin input voltage	64
Figure 15.	Power supply scheme	65
Figure 16.	Current consumption measurement scheme	66
Figure 17.	V _{REFINT} vs. temperature	70
Figure 18.	High-speed external clock source AC timing diagram	82
Figure 19.	Low-speed external clock source AC timing diagram	83
Figure 20.	Typical application with an 8 MHz crystal	84
Figure 21.	Typical application with a 32.768 kHz crystal	85
Figure 22.	HSI16 frequency vs. temperature	86
Figure 23.	HSI48 frequency versus temperature	87
Figure 24.	I/O input characteristics	94
Figure 25.	Current injection into FT_e input with diode active	95
Figure 26.	I/O AC characteristics definition	98
Figure 27.	Recommended NRST pin protection	99
Figure 28.	ADC accuracy characteristics	106
Figure 29.	ADC typical connection diagram	106
Figure 30.	12-bit buffered / non-buffered DAC	109
Figure 31.	SPI timing diagram - slave mode and CPHA = 0	118
Figure 32.	SPI timing diagram - slave mode and CPHA = 1	118
Figure 33.	SPI timing diagram - master mode	119
Figure 34.	I ² S slave timing diagram (Philips protocol)	120
Figure 35.	I ² S master timing diagram (Philips protocol)	121
Figure 36.	USART timing diagram in SPI master mode	122
Figure 37.	USART timing diagram in SPI slave mode	123
Figure 38.	USB timings – definition of data signal rise and fall time	124
Figure 39.	LQFP32 - Outline	126
Figure 40.	LQFP32 – Footprint example	129
Figure 41.	UFQFPN32 - Outline	130
Figure 42.	UFQFPN32 - Footprint example	133
Figure 43.	LQFP48 - Outline ⁽¹⁵⁾	134
Figure 44.	LQFP48 - Footprint example	136
Figure 45.	UFQFPN48 – Outline	137
Figure 46.	UFQFPN48 – Footprint example	138
Figure 47.	WLCSP52 - Outline	139
Figure 48.	WLCSP52 - Footprint example	141

Figure 49.	WLCSP52 package marking example	142
Figure 50.	LQFP64 - Outline ⁽¹⁵⁾	143
Figure 51.	UFBGA64 – Outline ⁽¹³⁾	146
Figure 52.	UFBGA64 – Footprint example	148
Figure 53.	LQFP80 - Outline ⁽¹⁵⁾	149
Figure 54.	LQFP80 - Footprint example	151
Figure 55.	LQFP100 - Outline ⁽¹⁵⁾	152
Figure 56.	LQFP100 - Footprint example	154
Figure 57.	UFBGA100 - Outline ⁽¹³⁾	155
Figure 58.	UFBGA100 - Footprint example	157

1 Introduction

This document provides information on STM32G0B1xB/xC/xE microcontrollers, such as description, functional overview, pin assignment and definition, electrical characteristics, packaging, and ordering codes.

Information on memory mapping and control registers is object of reference manual RM0444.

For information on the device errata with respect to the datasheet and reference manual, refer to the STM32G0B1xB/xC/xE errata sheet ES0548.

Information on Arm[®] Cortex[®]-M0+ core is available from the www.arm.com website.



arm

Note: Arm and Cortex are registered trademarks of Arm Limited (or its subsidiaries or affiliates) in the US and/or elsewhere.

The Arm word and logo are trademarks of Arm Limited (or its subsidiaries) in the US and/or elsewhere. All rights reserved.

2 Description

The STM32G0B1xB/xC/xE mainstream microcontrollers are based on high-performance Arm® Cortex®-M0+ 32-bit RISC core operating at up to 64 MHz frequency. Offering a high level of integration, they are suitable for a wide range of applications in consumer, industrial and appliance domains and ready for the Internet of Things (IoT) solutions.

The devices incorporate a memory protection unit (MPU), high-speed embedded memories (144 Kbytes of SRAM and up to 512 Kbytes of flash program memory with read protection, write protection, proprietary code protection, and securable area), DMA, an extensive range of system functions, enhanced I/Os, and peripherals. The devices offer standard communication interfaces (three I²Cs, three SPIs / two I²S, one HDMI CEC, one full-speed USB, two FD CANs, and six USARTs), one 12-bit ADC (2.5 MSps) with up to 19 channels, one 12-bit DAC with two channels, three fast comparators, an internal voltage reference buffer, a low-power RTC, an advanced control PWM timer running at up to double the CPU frequency, six general-purpose 16-bit timers with one running at up to double the CPU frequency, a 32-bit general-purpose timer, two basic timers, two low-power 16-bit timers, two watchdog timers, and a SysTick timer. The devices provide a fully integrated USB Type-C Power Delivery controller.

The devices operate within ambient temperatures from -40 to 125°C and with supply voltages from 1.7 V to 3.6 V. Optimized dynamic consumption combined with a comprehensive set of power-saving modes, low-power timers and low-power UART, allows the design of low-power applications.

VBAT direct battery input allows keeping RTC and backup registers powered.

The devices come in packages with 32 to 100 pins. Some packages with low pin count are available in two pinouts, standard and alternative. The devices with the alternative pinout, marked with N suffix, offer the V_{DDIO2} supply and an additional UCPD port. They are the best choice for UCPD/USB applications.

Table 2. Features and peripheral counts

Peripheral	STM32G0B1_									
	_KB/ _KC/ _KE	_KBxxN/ _KCxxN/ _KExxN	_CB/ _CC/ _CE	_CBxxN/ _CCxxN/ _CExxN	_NE	_RB/ _RC/ _RE	_RBxxN/ _RCxxN/ _RExxN	_MB/ _MC/ _ME	_VB/ _VC/ _VE	
Flash memory (Kbyte)	128/256 /512	128/256 /512	128/256 /512	128/256 /512	512	128/256 /512	128/256 /512	128/256 /512	128/256 /512	
SRAM (Kbyte)	128 (parity-protected) or 144 (not parity-protected)									
Timers	Advanced control	1 (16-bit) high frequency								
	General-purpose	6 (16-bit) + 1 (16-bit) high frequency + 1 (32-bit)								
	Basic	2 (16-bit)								
	Low-power	2 (16-bit)								
	SysTick	1								
	Watchdog	2								
Comm. interfaces	SPI [I ² S] ⁽¹⁾	3 [2] + 6 extra through USARTs								
	I ² C	3								
	USART	6								
	LPUART	2								
	USB	1 ⁽²⁾		1						
	UCPD	1 ⁽³⁾	2							
	FDCAN	2								
	CEC	1								
RTC	Yes									
Tamper pins	3									
VDDIO2 pin / VSS pin	No/No	Yes/No	No/No	Yes/Yes	Yes/Yes	No/No	Yes/Yes	Yes/Yes	Yes/Yes	
RNG / AES	No / No									
GPIOs	30	29	44	42	46	60	58	74	94	
Wakeup pins	4	3	4			5		7	8	
ADC channels (ext. + int.)	11 + 2	10 + 2	14 + 3		16 + 3					
DAC channels	2									
VREFBUF	No		Yes							
Analog comparators	3									
Max. CPU frequency	64 MHz									
Operating voltage	1.7 to 3.6 V									
Operating temperature ⁽⁴⁾	Ambient: -40 to 85 °C / -40 to 105 °C / -40 to 125 °C Junction: -40 to 105 °C / -40 to 125 °C / -40 to 130 °C									
Number of pins	32		48		52	64		80	100	

1. The numbers in brackets denote the count of SPI interfaces configurable as I²S interface.
2. The HSE crystal oscillator is not available on 32-pin packages. The precise clock for the USB peripheral must be provided by some other means.
3. One port with only one CC line available (supporting limited number of use cases).
4. Depends on order code. Refer to [Section 7: Ordering information](#) for details.

3 Functional overview

3.1 Arm[®] Cortex[®]-M0+ core with MPU

The Cortex-M0+ is an entry-level 32-bit Arm Cortex processor designed for a broad range of embedded applications. It offers significant benefits to developers, including:

- a simple architecture, easy to learn and program
- ultra-low power, energy-efficient operation
- excellent code density
- deterministic, high-performance interrupt handling
- upward compatibility with Cortex-M processor family
- platform security robustness, with integrated Memory Protection Unit (MPU).

The Cortex-M0+ processor is built on a highly area- and power-optimized 32-bit core, with a 2-stage pipeline Von Neumann architecture. The processor delivers exceptional energy efficiency through a small but powerful instruction set and extensively optimized design, providing high-end processing hardware including a single-cycle multiplier.

The Cortex-M0+ processor provides the exceptional performance expected of a modern 32-bit architecture, with a higher code density than other 8-bit and 16-bit microcontrollers.

Owing to embedded Arm core, the STM32G0B1xB/xC/xE devices are compatible with Arm tools and software.

The Cortex-M0+ is tightly coupled with a nested vectored interrupt controller (NVIC) described in [Section 3.13.1](#).

3.2 Memory protection unit

The memory protection unit (MPU) is used to manage the CPU accesses to memory to prevent one task to accidentally corrupt the memory or resources used by any other active task.

The MPU is especially helpful for applications where some critical or certified code has to be protected against the misbehavior of other tasks. It is usually managed by an RTOS (real-time operating system). If a program accesses a memory location that is prohibited by the MPU, the RTOS can detect it and take action. In an RTOS environment, the kernel can dynamically update the MPU area setting, based on the process to be executed.

The MPU is optional and can be bypassed for applications that do not need it.

3.3 Embedded flash memory

STM32G0B1xB/xC/xE devices feature up to 512 Kbytes of embedded flash memory available for storing code and data.

Flexible protections can be configured thanks to option bytes:

- Readout protection (RDP) to protect the whole memory. Three levels are available:
 - Level 0: no readout protection
 - Level 1: memory readout protection: the flash memory cannot be read from or written to if either debug features are connected, boot in RAM or bootloader is selected
 - Level 2: chip readout protection: debug features (Cortex-M0+ serial wire), boot in RAM and bootloader selection are disabled. This selection is irreversible.

Table 3. Access status versus readout protection level and execution modes

Area	Protection level	User execution			Debug, boot from RAM or boot from system memory (loader)		
		Read	Write	Erase	Read	Write	Erase
User memory	1	Yes	Yes	Yes	No	No	No
	2	Yes	Yes	Yes	N/A	N/A	N/A
System memory	1	Yes	No	No	Yes	No	No
	2	Yes	No	No	N/A	N/A	N/A
Option bytes	1	Yes	Yes	Yes	Yes	Yes	Yes
	2	Yes	No	No	N/A	N/A	N/A
Backup registers	1	Yes	Yes	N/A ⁽¹⁾	No	No	N/A ⁽¹⁾
	2	Yes	Yes	N/A	N/A	N/A	N/A
OTP	1	Yes	Yes	N/A	Yes	No	N/A
	2	Yes	Yes	N/A	N/A	N/A	N/A

1. Erased upon RDP change from Level 1 to Level 0.

- Write protection (WRP): the protected area is protected against erasing and programming. Two areas per bank can be selected, with 2-Kbyte granularity.
- Proprietary code readout protection (PCROP): a part of the flash memory can be protected against read and write from third parties. The protected area is execute-only: it can only be reached by the STM32 CPU as instruction code, while all other accesses (DMA, debug and CPU data read, write and erase) are strictly prohibited. An additional option bit (PCROP_RDP) determines whether the PCROP area is erased or not when the RDP protection is changed from Level 1 to Level 0.

The whole non-volatile memory embeds the error correction code (ECC) feature supporting:

- single error detection and correction
- double error detection
- readout of the ECC fail address from the ECC register

3.3.1 Securable area

A part of the flash memory can be hidden from the application once the code it contains is executed. As soon as the write-once SEC_PROT bit is set, the securable memory cannot be accessed until the system resets. The securable area generally contains the secure boot code to execute only once at boot. This helps to isolate secret code from untrusted application code.



3.4 Embedded SRAM

STM32G0B1xB/xC/xE devices have 128 Kbytes of embedded SRAM with parity. Hardware parity check allows memory data errors to be detected, which contributes to increasing functional safety of applications.

When the parity protection is not required because the application is not safety-critical, the parity memory bits can be used as additional SRAM, to increase its total size to 144 Kbytes.

The memory can be read/write-accessed at CPU clock speed, with 0 wait states.

3.5 Boot modes

At startup, the boot pin and boot selector option bit are used to select one of the three boot options:

- boot from User flash memory
- boot from System memory
- boot from embedded SRAM

The boot pin is shared with a standard GPIO and can be enabled through the boot selector option bit. If the BOOT0 pin selects the boot from the main flash memory of which the first location is empty, the flash memory empty checker forces the boot from the system memory.

The system memory contains an embedded boot loader. It manages the flash memory reprogramming through one of the following interfaces:

- USART on pins PA9/PA10, PC10/PC11, or PA2/PA3
- I²C-bus on pins PB6/PB7 or PB10/PB11
- SPI on pins PA4/PA5/PA6/PA7 or PB12/PB13/PB14/PB15
- USB on pins PA11/PA12
- FDCAN on pins PD0/PD1

When boot loader is executed, it configures some of the GPIOs out of their by-default high-Z state. Refer to AN2606 for more details on the boot loader and on the GPIO configuration when booting from the system memory.

3.6 Cyclic redundancy check calculation unit (CRC)

The CRC (cyclic redundancy check) calculation unit is used to get a CRC code using a configurable generator polynomial value and size.

Among other applications, CRC-based techniques are used to verify data transmission or storage integrity. In the scope of the EN/IEC 60335-1 standard, they offer a means of verifying the flash memory integrity. The CRC calculation unit helps compute a signature of the software during runtime, to be compared with a reference signature generated at link time and stored at a given memory location.

3.7 Power supply management

3.7.1 Power supply schemes

The STM32G0B1xB/xC/xE devices require a 1.7 V to 3.6 V operating supply voltage (V_{DD}). Several different power supplies are provided to specific peripherals:

- $V_{DD} = 1.7$ (1.60) to 3.6 V
 V_{DD} is the external power supply for the internal regulator and the system analog such as reset, power management and internal clocks. It is provided externally through VDD/VDDA pin.
 The minimum voltage of 1.7 V corresponds to power-on reset release threshold $V_{POR(max)}$. Once this threshold is crossed and power-on reset is released, the functionality is guaranteed down to power-down reset threshold $V_{PDR(min)}$.
- $V_{DDA} = 1.62$ V (ADC and COMP) / 1.8 V (DAC) / 2.4 V (VREFBUF) to 3.6 V
 V_{DDA} is the analog power supply for the A/D converter, D/A converter, voltage reference buffer and comparators. V_{DDA} voltage level is identical to V_{DD} voltage as it is provided externally through VDD/VDDA pin.
- $V_{DDIO1} = V_{DD}$
 V_{DDIO1} is the power supply for the I/Os. V_{DDIO1} voltage level is identical to V_{DD} voltage as it is provided externally through VDD/VDDA pin.
- $V_{DDIO2} = 1.65$ to 3.6 V
 V_{DDIO2} is the power supply from VDDIO2 pin for selected I/Os and V_{DDUSB} . On packages without VDDIO2 pin, V_{DDUSB} and V_{DDIO2} are internally connected with V_{DD} . Although V_{DDIO2} is independent of V_{DD} or V_{DDA} , it must not be applied without valid V_{DD} .
- $V_{BAT} = 1.55$ V to 3.6 V. V_{BAT} is the power supply (through a power switch) for RTC, TAMP, low-speed external 32.768 kHz oscillator and backup registers when V_{DD} is not present. V_{BAT} is provided externally through VBAT pin. When this pin is not available on the package, VBAT bonding pad is internally bonded to the VDD/VDDA pin.
- V_{REF+} is the analog peripheral input reference voltage, or the output of the internal voltage reference buffer (when enabled). When $V_{DDA} < 2$ V, V_{REF+} must be equal to V_{DDA} . When $V_{DDA} \geq 2$ V, V_{REF+} must be between 2 V and V_{DDA} . It can be grounded when the analog peripherals using V_{REF+} are not active.
 The internal voltage reference buffer supports two output voltages, which is configured with VRS bit of the VREFBUF_CSR register:
 - V_{REF+} around 2.048 V (requiring V_{DDA} equal to or higher than 2.4 V)
 - V_{REF+} around 2.5 V (requiring V_{DDA} equal to or higher than 2.8 V) V_{REF+} is delivered through VREF+ pin. On packages without VREF+ pin, V_{REF+} is internally connected with V_{DD} , and the internal voltage reference buffer must be kept disabled (refer to datasheets for package pinout description).
- V_{CORE} is an internal supply for digital peripherals, SRAM and flash memory. It is produced by an embedded linear voltage regulator. On top of V_{CORE} , the flash memory is also powered from V_{DD} .

Figure 2. Power supply overview

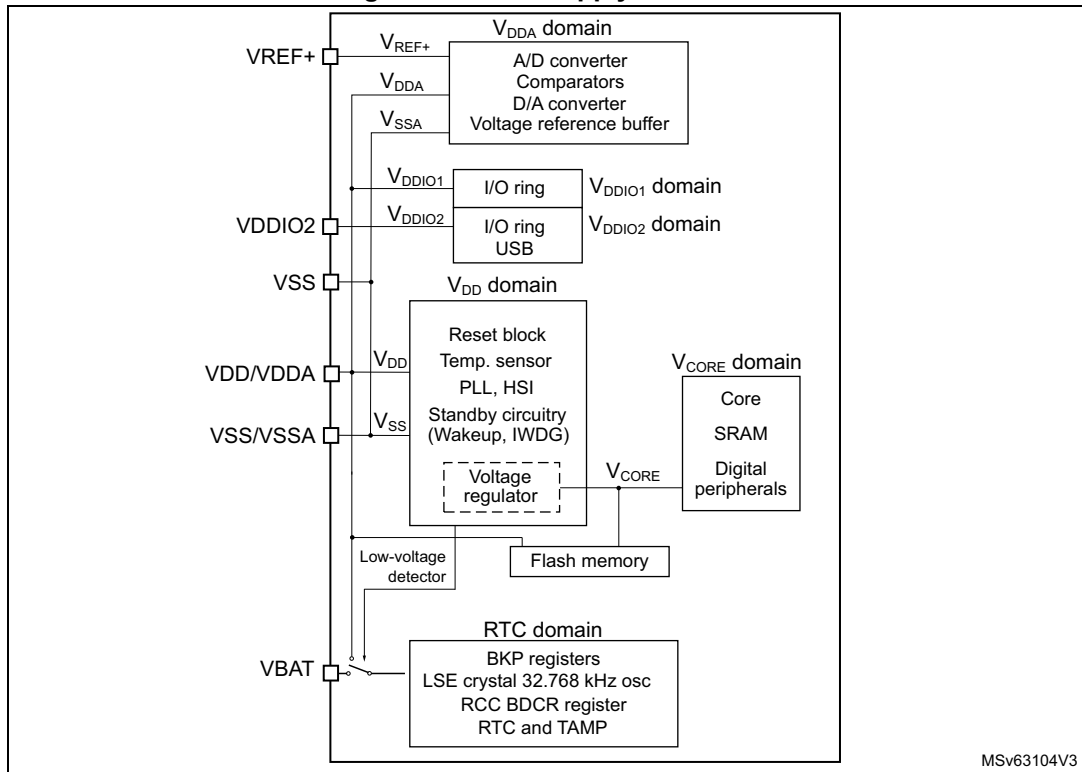

MSv63104V3

3.7.2 Power supply supervisor

The device has an integrated power-on/power-down (POR/PDR) reset active in all power modes except Shutdown and ensuring proper operation upon power-on and power-down. It maintains the device in reset when the supply voltage is below $V_{POR/PDR}$ threshold, without the need for an external reset circuit. Brownout reset (BOR) function allows extra flexibility. It can be enabled and configured through option bytes, by selecting one of four thresholds for rising V_{DD} and other four for falling V_{DD} .

The device also features an embedded programmable voltage detector (PVD) that monitors the V_{DD} power supply and compares it to V_{PVD} threshold. It allows generating an interrupt when V_{DD} level crosses the V_{PVD} threshold, selectively while falling, while rising, or while falling and rising. The interrupt service routine can then generate a warning message and/or put the MCU into a safe state. The PVD is enabled by software.

3.7.3 Voltage regulator

Two embedded linear voltage regulators, main regulator (MR) and low-power regulator (LPR), supply most of digital circuitry in the device.

The MR is used in Run and Sleep modes. The LPR is used in Low-power run, Low-power sleep and Stop modes.

In Standby and Shutdown modes, both regulators are powered down and their outputs set in high-impedance state, such as to bring their current consumption close to zero. However, SRAM data retention is possible in Standby mode, in which case the LPR remains active and it only supplies the SRAM.

3.7.4 Low-power modes

By default, the microcontroller is in Run mode after system or power reset. It is up to the user to select one of the low-power modes described below.

Sleep mode

In Sleep mode, only the CPU is stopped. All peripherals continue to operate and can wake up the CPU when an interrupt/event occurs.

Low-power run mode

This mode is achieved with V_{CORE} supplied by the low-power regulator to minimize the regulator's operating current. The code can be executed from SRAM or from flash memory, and the CPU frequency is limited to 2 MHz. The peripherals with independent clock can be clocked by HSI16.

Low-power sleep mode

This mode is entered from the low-power run mode. Only the CPU clock is stopped. When wakeup is triggered by an event or an interrupt, the system reverts to the Low-power run mode.

Stop 0 and Stop 1 modes

In Stop 0 and Stop 1 modes, the device achieves the lowest power consumption while retaining the SRAM and register contents. All clocks in the V_{CORE} domain are stopped. The PLL, as well as the HSI16 RC oscillator and the HSE crystal oscillator are disabled. The LSE or LSI keep running. The RTC can remain active (Stop mode with RTC, Stop mode without RTC).

Some peripherals with wakeup capability can enable the HSI16 RC during Stop mode, so as to get clock for processing the wakeup event. The main regulator remains active in Stop 0 mode while it is turned off in Stop 1 mode.

Standby mode

The Standby mode is used to achieve the lowest power consumption, with POR/PDR always active in this mode. The main regulator is switched off to power down V_{CORE} domain. The low-power regulator is either switched off or kept active. In the latter case, it only supplies SRAM to ensure data retention. The PLL, as well as the HSI16 RC oscillator and the HSE crystal oscillator are also powered down. The RTC can remain active (Standby mode with RTC, Standby mode without RTC).

For each I/O, the software can determine whether a pull-up, a pull-down or no resistor shall be applied to that I/O during Standby mode.

Upon entering Standby mode, register contents are lost except for registers in the RTC domain and standby circuitry. The SRAM contents can be retained through register setting.

The device exits Standby mode upon external reset event (NRST pin), IWDG reset event, wakeup event (WKUP pin, configurable rising or falling edge), RTC event (alarm, periodic wakeup, timestamp), TAMP event, or when a failure is detected on LSE (CSS on LSE).

Shutdown mode

The Shutdown mode allows to achieve the lowest power consumption. The internal regulator is switched off to power down the V_{CORE} domain. The PLL, as well as the HSI16 and LSI RC-oscillators and HSE crystal oscillator are also powered down. The RTC can remain active (Shutdown mode with RTC, Shutdown mode without RTC).

The BOR is not available in Shutdown mode. No power voltage monitoring is possible in this mode. Therefore, switching to RTC domain is not supported.

SRAM and register contents are lost except for registers in the RTC domain.

The device exits Shutdown mode upon external reset event (NRST pin), wakeup event (WKUP pin, configurable rising or falling edge), RTC event (alarm, periodic wakeup, timestamp), or TAMP event.

3.7.5 Reset mode

During and upon exiting reset, the schmitt triggers of I/Os are disabled so as to reduce power consumption. In addition, when the reset source is internal, the built-in pull-up resistor on NRST pin is deactivated.

3.7.6 VBAT operation

The V_{BAT} power domain, consuming very little energy, includes RTC, and LSE oscillator and backup registers.

In VBAT mode, the RTC domain is supplied from VBAT pin. The power source can be, for example, an external battery or an external supercapacitor. Two anti-tamper detection pins are available.

The RTC domain can also be supplied from V_{DD} .

By means of a built-in switch, an internal voltage supervisor allows automatic switching of RTC domain powering between V_{DD} and voltage from VBAT pin to ensure that the supply voltage of the RTC domain (V_{BAT}) remains within valid operating conditions. If both voltages are valid, the RTC domain is supplied from V_{DD} .

An internal circuit for charging the battery on VBAT pin can be activated if the V_{DD} voltage is within a valid range.

Note: External interrupts and RTC alarm/events cannot cause the microcontroller to exit the VBAT mode, as in that mode the V_{DD} is not within a valid range.

3.8 Interconnect of peripherals

Several peripherals have direct connections between them. This allows autonomous communication between peripherals, saving CPU resources thus power supply consumption. In addition, these hardware connections allow fast and predictable latency.

Depending on peripherals, these interconnections can operate in Run, Sleep and Stop modes.

Table 4. Interconnect of peripherals

Interconnect source	Interconnect destination	Interconnect action	Run Low-power run	Sleep Low-power sleep	Stop
TIMx	TIMx	Timer synchronization or chaining	Y	Y	-
	ADCx DACx	Conversion triggers	Y	Y	-
	DMA	Memory-to-memory transfer trigger	Y	Y	-
	COMPx	Comparator output blanking	Y	Y	-
COMPx	TIM1,2,3,4	Timer input channel, trigger, break from analog signals comparison	Y	Y	-
	LPTIMERx	Low-power timer triggered by analog signals comparison	Y	Y	Y
ADCx	TIM1	Timer triggered by analog watchdog	Y	Y	-
RTC	TIM16	Timer input channel from RTC events	Y	Y	-
	LPTIMERx	Low-power timer triggered by RTC alarms or tampers	Y	Y	Y
All clock sources (internal and external)	TIM14,16,17	Clock source used as input channel for RC measurement and trimming	Y	Y	-
CSS RAM (parity error) Flash memory (ECC error) COMPx PVD	TIM1,15,16,17	Timer break	Y	Y	-
CPU (hard fault)	TIM1,15,16,17	Timer break	Y	-	-
GPIO	TIMx	External trigger	Y	Y	-
	LPTIMERx	External trigger	Y	Y	Y
	ADC DACx	Conversion external trigger	Y	Y	-

3.9 Clocks and startup

The clock controller distributes the clocks coming from different oscillators to the core and the peripherals. It also manages clock gating for low-power modes and ensures clock robustness. It features:

- **Clock prescaler:** to get the best trade-off between speed and current consumption, the clock frequency to the CPU and peripherals can be adjusted by a programmable prescaler
- **Safe clock switching:** clock sources can be changed safely on the fly in run mode through a configuration register.
- **Clock management:** to reduce power consumption, the clock controller can stop the clock to the core, individual peripherals or memory.
- **System clock source:** three different sources can deliver SYSCCLK system clock:
 - 4-48 MHz high-speed oscillator with external crystal or ceramic resonator (HSE). It can supply clock to system PLL. The HSE can also be configured in bypass mode for an external clock.
 - 16 MHz high-speed internal RC oscillator (HSI16), trimmable by software. It can supply clock to system PLL.
 - System PLL with maximum output frequency of 64 MHz. It can be fed with HSE or HSI16 clocks.
- **Auxiliary clock source:** two ultra-low-power clock sources for the real-time clock (RTC):
 - 32.768 kHz low-speed oscillator with external crystal (LSE), supporting four drive capability modes. The LSE can also be configured in bypass mode for using an external clock.
 - 32 kHz low-speed internal RC oscillator (LSI) with $\pm 5\%$ accuracy, also used to clock an independent watchdog.
- **USB clock source:**
 - HSI 48 MHz in association with CRS can provide a dedicated clock to USB FS allowing the peripheral to operate as device without requiring an external resonator
- **Peripheral clock sources:** several peripherals (I2S, USARTs, I2Cs, LPTIMs, ADC, USB FS) have their own clock independent of the system clock.
- **Clock security system (CSS):** in the event of HSE clock failure, the system clock is automatically switched to HSI16 and, if enabled, a software interrupt is generated. LSE clock failure can also be detected and generate an interrupt. The CCS feature can be enabled by software.
- **Clock output:**
 - **MCO (microcontroller clock output)** provides one of the internal clocks for external use by the application
 - **LSCO (low speed clock output)** provides LSI or LSE in all low-power modes (except in VBAT operation).

Several prescalers allow the application to configure AHB and APB domain clock frequencies, 64 MHz at maximum.

3.10 General-purpose inputs/outputs (GPIOs)

Each of the GPIO pins can be configured by software as output (push-pull or open-drain), as input (with or without pull-up or pull-down) or as peripheral alternate function (AF). Most of the GPIO pins are shared with special digital or analog functions.

Through a specific sequence, this special function configuration of I/Os can be locked, such as to avoid spurious writing to I/O control registers.

3.11 Direct memory access controller (DMA)

The direct memory access (DMA) controller is a bus master and system peripheral with single-AHB architecture.

With 12 channels, it performs data transfers between memory-mapped peripherals and/or memories, to offload the CPU.

Each channel is dedicated to managing memory access requests from one or more peripherals. The unit includes an arbiter for handling the priority between DMA requests.

Main features of the DMA controller:

- Single-AHB master
- Peripheral-to-memory, memory-to-peripheral, memory-to-memory and peripheral-to-peripheral data transfers
- Access, as source and destination, to on-chip memory-mapped devices such as flash memory, SRAM, and AHB and APB peripherals
- All DMA channels independently configurable:
 - Each channel is associated either with a DMA request signal coming from a peripheral, or with a software trigger in memory-to-memory transfers. This configuration is done by software.
 - Priority between the requests is programmable by software (four levels per channel: very high, high, medium, low) and by hardware in case of equality (such as request to channel 1 has priority over request to channel 2).
 - Transfer size of source and destination are independent (byte, half-word, word), emulating packing and unpacking. Source and destination addresses must be aligned on the data size.
 - Support of transfers from/to peripherals to/from memory with circular buffer management
 - Programmable number of data to be transferred: 0 to $2^{16} - 1$
- Generation of an interrupt request per channel. Each interrupt request originates from any of the three DMA events: transfer complete, half transfer, or transfer error.

3.12 DMA request multiplexer (DMAMUX)

The DMAMUX request multiplexer enables routing a DMA request line between the peripherals and the DMA controller. Each channel selects a unique DMA request line, unconditionally or synchronously with events from its DMAMUX synchronization inputs. DMAMUX may also be used as a DMA request generator from programmable events on its input trigger signals.

3.13 Interrupts and events

The device flexibly manages events causing interrupts of linear program execution, called exceptions. The Cortex-M0+ processor core, a nested vectored interrupt controller (NVIC) and an extended interrupt/event controller (EXTI) are the assets contributing to handling the exceptions. Exceptions include core-internal events such as, for example, a division by zero and, core-external events such as logical level changes on physical lines. Exceptions result in interrupting the program flow, executing an interrupt service routine (ISR) then resuming the original program flow.

The processor context (contents of program pointer and status registers) is stacked upon program interrupt and unstacked upon program resume, by hardware. This avoids context stacking and unstacking in the interrupt service routines (ISRs) by software, thus saving time, code and power. The ability to abandon and restart load-multiple and store-multiple operations significantly increases the device's responsiveness in processing exceptions.

3.13.1 Nested vectored interrupt controller (NVIC)

The configurable nested vectored interrupt controller is tightly coupled with the core. It handles physical line events associated with a non-maskable interrupt (NMI) and maskable interrupts, and Cortex-M0+ exceptions. It provides flexible priority management.

The tight coupling of the processor core with NVIC significantly reduces the latency between interrupt events and start of corresponding interrupt service routines (ISRs). The ISR vectors are listed in a vector table, stored in the NVIC at a base address. The vector address of an ISR to execute is hardware-built from the vector table base address and the ISR order number used as offset.

If a higher-priority interrupt event happens while a lower-priority interrupt event occurring just before is waiting for being served, the later-arriving higher-priority interrupt event is served first. Another optimization is called tail-chaining. Upon a return from a higher-priority ISR then start of a pending lower-priority ISR, the unnecessary processor context unstacking and stacking is skipped. This reduces latency and contributes to power efficiency.

Features of the NVIC:

- Low-latency interrupt processing
- 4 priority levels
- Handling of a non-maskable interrupt (NMI)
- Handling of 32 maskable interrupt lines
- Handling of 10 Cortex-M0+ exceptions
- Later-arriving higher-priority interrupt processed first
- Tail-chaining
- Interrupt vector retrieval by hardware

3.13.2 Extended interrupt/event controller (EXTI)

The extended interrupt/event controller adds flexibility in handling physical line events and allows identifying wake-up events at processor wakeup from Stop mode.

The EXTI controller has a number of channels, of which some with rising, falling or rising, and falling edge detector capability. Any GPIO and a few peripheral signals can be connected to these channels.

The channels can be independently masked.

The EXTI controller can capture pulses shorter than the internal clock period.

A register in the EXTI controller latches every event even in Stop mode, which allows the software to identify the origin of the processor's wake-up from Stop mode or, to identify the GPIO and the edge event having caused an interrupt.

3.14 Analog-to-digital converter (ADC)

A native 12-bit analog-to-digital converter is embedded into STM32G0B1xB/xC/xE devices. The ADC has up to 16 external channels and 3 internal channels (temperature sensor, voltage reference, V_{BAT} monitoring). It performs conversions in single-shot or scan mode. In scan mode, automatic conversion is performed on a selected group of analog inputs.

The ADC frequency is independent from the CPU frequency, allowing maximum sampling rate of ~2.5 MSps even with a low CPU speed. An auto-shutdown function guarantees that the ADC is powered off except during the active conversion phase.

The ADC can be served by the DMA controller. It can operate in the whole V_{DD} supply range.

The ADC features a hardware oversampler up to 256 samples, improving the resolution to 16 bits (refer to AN2668).

An analog watchdog feature allows very precise monitoring of the converted voltage of one, some or all scanned channels. An interrupt is generated when the converted voltage is outside the programmed thresholds.

The events generated by the general-purpose timers (TIMx) can be internally connected to the ADC start triggers, to allow the application to synchronize A/D conversions with timers.

3.14.1 Temperature sensor

The temperature sensor (TS) generates a voltage V_{TS} that varies linearly with temperature.

The temperature sensor is internally connected to an ADC input to convert the sensor output voltage into a digital value.

The sensor provides good linearity but it has to be calibrated to obtain good overall accuracy of the temperature measurement. As the offset of the temperature sensor may vary from part to part due to process variation, the uncalibrated internal temperature sensor is suitable only for relative temperature measurements.

To improve the accuracy of the temperature sensor, each part is individually factory-calibrated by ST. The resulting calibration data are stored in the part's engineering bytes, accessible in read-only mode.

Table 5. Temperature sensor calibration values

Calibration value name	Description	Memory address
TS_CAL1	TS ADC raw data acquired at a temperature of 30 °C (± 5 °C), $V_{DDA} = V_{REF+} = 3.0$ V (± 10 mV)	0x1FFF 75A8 - 0x1FFF 75A9
TS_CAL2	TS ADC raw data acquired at a temperature of 130 °C (± 5 °C), $V_{DDA} = V_{REF+} = 3.0$ V (± 10 mV)	0x1FFF 75CA - 0x1FFF 75CB

3.14.2 Internal voltage reference (V_{REFINT})

The internal voltage reference (V_{REFINT}) provides a stable (bandgap) voltage output for the ADC and comparators. V_{REFINT} is internally connected to an ADC input. The V_{REFINT} voltage is individually precisely measured for each part by ST during production test and stored in the part's engineering bytes. It is accessible in read-only mode.

Table 6. Internal voltage reference calibration values

Calibration value name	Description	Memory address
V_{REFINT}	Raw data acquired at a temperature of 30 °C (± 5 °C), $V_{DDA} = V_{REF+} = 3.0$ V (± 10 mV)	0x1FFF 75AA - 0x1FFF 75AB

3.14.3 V_{BAT} battery voltage monitoring

This embedded hardware feature allows the application to measure the V_{BAT} battery voltage using an internal ADC input. As the V_{BAT} voltage may be higher than V_{DDA} and thus outside the ADC input range, the VBAT pin is internally connected to a bridge divider by three. As a consequence, the converted digital value is one third the V_{BAT} voltage.

3.15 Digital-to-analog converter (DAC)

The 2-channel 12-bit buffered DAC converts a digital value into an analog voltage available on the channel output. The architecture of either channel is based on integrated resistor string and an inverting amplifier. The digital circuitry is common for both channels.

Features of the DAC:

- Two DAC output channels
- 8-bit or 12-bit output mode
- Buffer offset calibration (factory and user trimming)
- Left or right data alignment in 12-bit mode
- Synchronized update capability
- Noise-wave generation
- Triangular-wave generation
- Independent or simultaneous conversion for DAC channels
- DMA capability for either DAC channel
- Triggering with timer events, synchronized with DMA
- Triggering with external events
- Sample-and-hold low-power mode, with internal or external capacitor

3.16 Voltage reference buffer (VREFBUF)

When enabled, an embedded buffer provides the internal reference voltage to analog blocks (for example ADC) and to VREF+ pin for external components.

The internal voltage reference buffer supports two voltages:

- 2.048 V
- 2.5 V

An external voltage reference can be provided through the VREF+ pin when the internal voltage reference buffer is disabled.

On some packages, the VREF+ pad of the silicon die is double-bonded with supply pad to common VDD/VDDA pin and so the internal voltage reference buffer cannot be used.

3.17 Comparators (COMP)

Three embedded rail-to-rail analog comparators have programmable reference voltage (internal or external), hysteresis, speed (low for low-power) and output polarity.

The reference voltage can be one of the following:

- external, from an I/O
- internal, from DAC
- internal reference voltage (V_{REFINT}) or its submultiple (1/4, 1/2, 3/4)

The comparators can wake up the device from Stop mode, generate interrupts, breaks or triggers for the timers and can be also combined into a window comparator.

3.18 Timers and watchdogs

The device includes an advanced-control timer, seven general-purpose timers, two basic timers, two low-power timers, two watchdog timers and a SysTick timer. [Table 7](#) compares features of the advanced-control, general-purpose and basic timers.

Table 7. Timer feature comparison

Timer type	Timer	Counter resolution	Counter type	Maximum operating frequency	Prescaler factor	DMA request generation	Capture/compare channels	Complementary outputs
Advanced-control	TIM1	16-bit	Up, down, up/down	128 MHz	Integer from 1 to 2 ¹⁶	Yes	4 + 2 internal	3
General-purpose	TIM2	32-bit	Up, down, up/down	64 MHz	Integer from 1 to 2 ¹⁶	Yes	4	-
	TIM3	16-bit	Up, down, up/down	64 MHz	Integer from 1 to 2 ¹⁶	Yes	4	-
	TIM4	16-bit	Up, down, up/down	64 MHz	Integer from 1 to 2 ¹⁶	Yes	4	-
	TIM14	16-bit	Up	64 MHz	Integer from 1 to 2 ¹⁶	No	1	-
	TIM15	16-bit	Up	128 MHz	Integer from 1 to 2 ¹⁶	Yes	2	1
	TIM16 TIM17	16-bit	Up	64 MHz	Integer from 1 to 2 ¹⁶	Yes	1	1
Basic	TIM6 TIM7	16-bit	Up	64 MHz	Integer from 1 to 2 ¹⁶	Yes	-	-
Low-power	LPTIM1 LPTIM2	16-bit	Up	64 MHz	2 ⁿ where n=0 to 7	No	N/A	-

3.18.1 Advanced-control timer (TIM1)

The advanced-control timer can be seen as a three-phase PWM unit multiplexed on 6 channels. It has complementary PWM outputs with programmable inserted dead-times. It can also be seen as a complete general-purpose timer. The four independent channels can be used for:

- input capture
- output compare
- PWM output (edge or center-aligned modes) with full modulation capability (0-100%)
- one-pulse mode output

On top of these, there are two internal channels that can be used.

In debug mode, the advanced-control timer counter can be frozen and the PWM outputs disabled, so as to turn off any power switches driven by these outputs.

Many features are shared with those of the general-purpose TIMx timers (described in [Section 3.18.2](#)) using the same architecture, so the advanced-control timers can work together with the TIMx timers via the Timer Link feature for synchronization or event chaining.

3.18.2 General-purpose timers (TIM2, 3, 4, 14, 15, 16, 17)

There are seven synchronizable general-purpose timers embedded in the device (refer to [Table 7](#) for comparison). Each general-purpose timer can be used to generate PWM outputs or act as a simple timebase.

- TIM2, TIM3, and TIM4

These are full-featured general-purpose timers:

- TIM2 with 32-bit auto-reload up/downcounter and 16-bit prescaler
- TIM3 and TIM4 with 16-bit auto-reload up/downcounter and 16-bit prescaler

They have four independent channels for input capture/output compare, PWM or one-pulse mode output. They can operate in combination with other general-purpose timers via the Timer Link feature for synchronization or event chaining. They can generate independent DMA request and support quadrature encoders. Their counter can be frozen in debug mode.

- TIM14

This timer is based on a 16-bit auto-reload upcounter and a 16-bit prescaler. It has one channel for input capture/output compare, PWM output or one-pulse mode output. Its counter can be frozen in debug mode.

- TIM15, TIM16, TIM17

These are general-purpose timers featuring:

- 16-bit auto-reload upcounter and 16-bit prescaler
- 2 channels and 1 complementary channel for TIM15
- 1 channel and 1 complementary channel for TIM16 and TIM17

All channels can be used for input capture/output compare, PWM or one-pulse mode output. The timers can operate together via the Timer Link feature for synchronization or event chaining. They can generate independent DMA request. Their counters can be frozen in debug mode.

3.18.3 Basic timers (TIM6 and TIM7)

These timers are mainly used for triggering DAC conversions. They can also be used as generic 16-bit timebases.

3.18.4 Low-power timers (LPTIM1 and LPTIM2)

These timers have an independent clock. When fed with LSE, LSI or external clock, they keep running in Stop mode and they can wake up the system from it.

Features of LPTIM1 and LPTIM2:

- 16-bit up counter with 16-bit autoreload register
- 16-bit compare register
- Configurable output (pulse, PWM)
- Continuous/one-shot mode
- Selectable software/hardware input trigger
- Selectable clock source:
 - Internal: LSE, LSI, HSI16 or APB clocks
 - External: over LPTIM input (working even with no internal clock source running, used by pulse counter application)
- Programmable digital glitch filter
- Encoder mode

3.18.5 Independent watchdog (IWDG)

The independent watchdog is based on an 8-bit prescaler and 12-bit downcounter with user-defined refresh window. It is clocked from an independent 32 kHz internal RC (LSI). Independent of the main clock, it can operate in Stop and Standby modes. It can be used either as a watchdog to reset the device when a problem occurs, or as a free-running timer for application timeout management. It is hardware- or software-configurable through the option bytes. Its counter can be frozen in debug mode.

3.18.6 System window watchdog (WWDG)

The window watchdog is based on a 7-bit downcounter that can be set as free-running. It can be used as a watchdog to reset the device when a problem occurs. It is clocked by the system clock. It has an early-warning interrupt capability. Its counter can be frozen in debug mode.

3.18.7 SysTick timer

This timer is dedicated to real-time operating systems, but it can also be used as a standard down counter.

Features of SysTick timer:

- 24-bit down counter
- Autoreload capability
- Maskable system interrupt generation when the counter reaches 0
- Programmable clock source

3.19 Real-time clock (RTC), tamper (TAMP) and backup registers

The device embeds an RTC and five 32-bit backup registers, located in the RTC domain of the silicon die.

The ways of powering the RTC domain are described in [Section 3.7.6](#).

The RTC is an independent BCD timer/counter.

Features of the RTC:

- Calendar with subsecond, seconds, minutes, hours (12 or 24 format), week day, date, month, year, in BCD (binary-coded decimal) format
- Automatic correction for 28, 29 (leap year), 30, and 31 days of the month
- Programmable alarm
- On-the-fly correction from 1 to 32767 RTC clock pulses, usable for synchronization with a master clock
- Reference clock detection - a more precise second-source clock (50 or 60 Hz) can be used to improve the calendar precision
- Digital calibration circuit with 0.95 ppm resolution, to compensate for quartz crystal inaccuracy
- Two anti-tamper detection pins with programmable filter
- Timestamp feature to save a calendar snapshot, triggered by an event on the timestamp pin or a tamper event, or by switching to VBAT mode
- 17-bit auto-reload wakeup timer (WUT) for periodic events, with programmable resolution and period
- Multiple clock sources and references:
 - A 32.768 kHz external crystal (LSE)
 - An external resonator or oscillator (LSE)
 - The internal low-power RC oscillator (LSI, with typical frequency of 32 kHz)
 - The high-speed external clock (HSE) divided by 32

When clocked by LSE, the RTC operates in VBAT mode and in all low-power modes. When clocked by LSI, the RTC does not operate in VBAT mode, but it does in low-power modes except for the Shutdown mode.

All RTC events (Alarm, WakeUp Timer, Timestamp or Tamper) can generate an interrupt and wake the device up from the low-power modes.

The backup registers allow keeping 20 bytes of user application data in the event of V_{DD} failure, if a valid backup supply voltage is provided on VBAT pin. They are not affected by the system reset, power reset, and upon the device's wakeup from Standby or Shutdown modes.

3.20 Inter-integrated circuit interface (I2C)

The device embeds three I2C peripherals. Refer to [Table 8](#) for the features.

The I²C-bus interface handles communication between the microcontroller and the serial I²C-bus. It controls all I²C-bus-specific sequencing, protocol, arbitration and timing.

Features of the I2C peripheral:

- I²C-bus specification and user manual rev. 5 compatibility:
 - Slave and master modes, multimaster capability
 - Standard-mode (Sm), with a bitrate up to 100 kbit/s
 - Fast-mode (Fm), with a bitrate up to 400 kbit/s
 - Fast-mode Plus (Fm+), with a bitrate up to 1 Mbit/s and extra output drive I/Os
 - 7-bit and 10-bit addressing mode, multiple 7-bit slave addresses
 - Programmable setup and hold times
 - Clock stretching
- SMBus specification rev 3.0 compatibility:
 - Hardware PEC (packet error checking) generation and verification with ACK control
 - Command and data acknowledge control
 - Address resolution protocol (ARP) support
 - Host and Device support
 - SMBus alert
 - Timeouts and idle condition detection
- PMBus rev 1.3 standard compatibility
- Independent clock: a choice of independent clock sources allowing the I2C communication speed to be independent of the PCLK reprogramming
- Wakeup from Stop mode on address match
- Programmable analog and digital noise filters
- 1-byte buffer with DMA capability

Table 8. I²C implementation

I ² C features ⁽¹⁾	I2C1 I2C2	I2C3
Standard mode (up to 100 kbit/s)	X	X
Fast mode (up to 400 kbit/s)	X	X
Fast Mode Plus (up to 1 Mbit/s) with extra output drive I/Os	X	X
Programmable analog and digital noise filters	X	X
SMBus/PMBus hardware support	X	-
Independent clock	X	-
Wakeup from Stop mode on address match	X	-

1. X: supported

3.21 Universal synchronous/asynchronous receiver transmitter (USART)

The device embeds universal synchronous/asynchronous receivers/transmitters that communicate at speeds of up to 8 Mbit/s.

They provide hardware management of the CTS, RTS and RS485 DE signals, multiprocessor communication mode, SPI synchronous communication and single-wire half-duplex communication mode. Some can also support SmartCard communication (ISO 7816), IrDA SIR ENDEC, LIN Master/Slave capability and auto baud rate feature, and have a clock domain independent of the CPU clock, which allows them to wake up the MCU from Stop mode. The wakeup events from Stop mode are programmable and can be:

- start bit detection
- any received data frame
- a specific programmed data frame

All USART interfaces can be served by the DMA controller.

Table 9. USART implementation

USART modes/features ⁽¹⁾	USART1 USART2 USART3	USART4 USART5 USART6
Hardware flow control for modem	X	X
Continuous communication using DMA	X	X
Multiprocessor communication	X	X
SPI emulation master/slave (synchronous mode)	X	X
Smartcard mode	X	-
Single-wire half-duplex communication	X	X
IrDA SIR ENDEC block	X	-
LIN mode	X	-
Dual clock domain and wakeup from Stop mode	X	-
Receiver timeout interrupt	X	-
Modbus communication	X	-
Auto baud rate detection	X	-
Driver Enable	X	X

1. X: supported

3.22 Low-power universal asynchronous receiver transmitter (LPUART)

The device embeds two LPUARTs. The peripheral supports asynchronous serial communication with minimum power consumption. It supports half duplex single wire communication and modem operations (CTS/RTS). It allows multiprocessor communication.

The LPUART has a clock domain independent of the CPU clock, and can wakeup the system from Stop mode. The Stop mode wakeup events are programmable and can be:

- start bit detection
- any received data frame
- a specific programmed data frame



Only a 32.768 kHz clock (LSE) is needed to allow LPUART communication up to 9600 baud. Therefore, even in Stop mode, the LPUART can wait for an incoming frame while having an extremely low energy consumption. Higher speed clock can be used to reach higher baudrates.

The LPUART interface can be served by the DMA controller.

3.23 Serial peripheral interface (SPI)

The device contains three SPIs running at up to 32 Mbits/s in master and slave modes. It supports half-duplex, full-duplex and simplex communications. A 3-bit prescaler gives eight master mode frequencies. The frame size is configurable from 4 bits to 16 bits. The SPI peripherals support NSS pulse mode, TI mode and hardware CRC calculation.

The SPI peripherals can be served by the DMA controller.

The I²S interface mode of the SPI peripheral (if supported, see the following table) supports four different audio standards can operate as master or slave, in half-duplex communication mode. It can be configured to transfer 16 and 24 or 32 bits with 16-bit or 32-bit data resolution and synchronized by a specific signal. Audio sampling frequency from 8 kHz up to 192 kHz can be set by an 8-bit programmable linear prescaler. When operating in master mode, it can output a clock for an external audio component at 256 times the sampling frequency.

Table 10. SPI/I2S implementation

SPI features ⁽¹⁾	SPI1 SPI2	SPI3
Hardware CRC calculation	X	X
Rx/Tx FIFO	X	X
NSS pulse mode	X	X
I ² S mode	X	-
TI mode	X	X

1. X = supported.

3.24 Universal serial bus full-speed host/device interface (USB)

The devices embed a USB controller with full-speed USB device and host functionality compliant with the USB specification version 2.0. The internal USB PHY supports USB FS signaling, embedded DP pull-up and also battery charging detection according to Battery Charging Specification Revision 1.2. The USB interface implements a full-speed (12 Mbit/s) function interface with added support for USB 2.0 Link Power Management. It has software-configurable endpoint setting with packet memory of 2 KB and suspend/resume support. It requires a precise 48 MHz clock that is generated from the internal main PLL (the clock source must come from a high-speed external clock, that is, from an external source or an oscillator, see note) or by the internal 48 MHz oscillator in automatic trimming mode. The synchronization for this oscillator can be taken from the USB data stream itself (SOF signalization) which allows crystal less operation in USB device mode.

Note: On the STM32G0B1Kx device, only HSE external source clock is available (HSE bypass).

3.25 USB Type-C Power Delivery controller

The device embeds two controllers (UCPD1 and UCPD2) compliant with USB Type-C Rev. 1.2 and USB Power Delivery Rev. 3.0 specifications.

The controllers use specific I/Os supporting the USB Type-C and USB Power Delivery requirements, featuring:

- USB Type-C pull-up (R_p , all values) and pull-down (R_d) resistors
- “Dead battery” support
- USB Power Delivery message transmission and reception
- FRS (fast role swap) support

The digital controller handles notably:

- USB Type-C level detection with de-bounce, generating interrupts
- FRS detection, generating an interrupt
- byte-level interface for USB Power Delivery payload, generating interrupts (DMA compatible)
- USB Power Delivery timing dividers (including a clock pre-scaler)
- CRC generation/checking
- 4b5b encode/decode
- ordered sets (with a programmable ordered set mask at receive)
- frequency recovery in receiver during preamble

The interface offers low-power operation compatible with Stop mode, maintaining the capacity to detect incoming USB Power Delivery messages and FRS signaling.

3.26 Controller area network (FDCAN)

The controller area network (CAN) subsystem consists of two CAN modules and a message RAM.

The CAN modules are compliant with ISO 11898-1 (CAN protocol specification version 2.0 part A, B) and CAN FD protocol specification version 1.0.

The 1-Kbyte message RAM per CAN module implements filters, receive FIFOs, receive buffers, transmit event FIFOs, and transmit buffers.

3.27 Development support

3.27.1 Serial wire debug port (SW-DP)

An Arm SW-DP interface is provided to allow a serial wire debugging tool to be connected to the MCU.

4 Pinouts, pin description and alternate functions

The devices housed in 32-pin, 48-pin, and 64-pin packages come in two variants - "GP" and "N" (the latter with ordering code having N behind the temperature range digit). Refer to [Table 2: Features and peripheral counts](#) for differences.

Figure 3. STM32G0B1KxT LQFP32 pinout

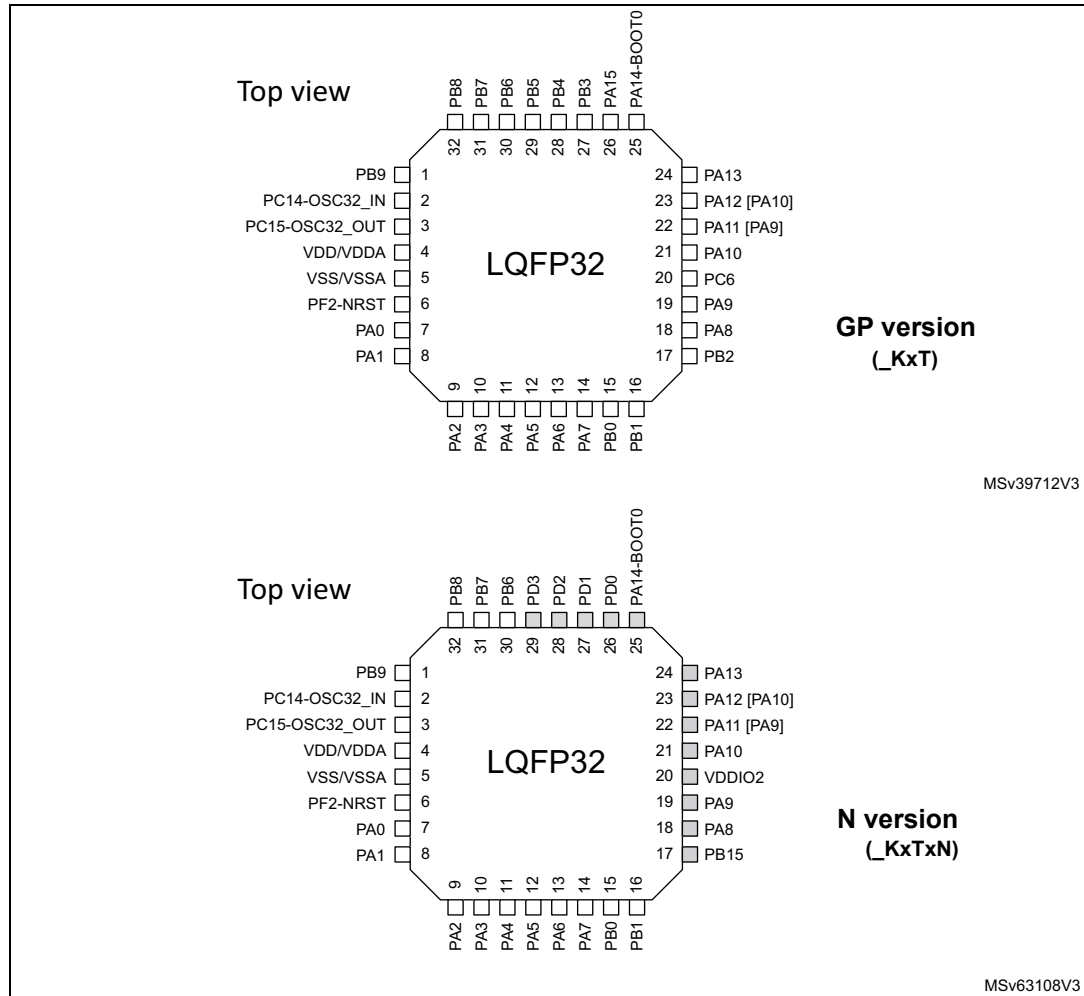

1. The I/O pins supplied by V_{DDIO2} are shown in dark gray.

Figure 4. STM32G0B1KxU UFQFPN32 pinout

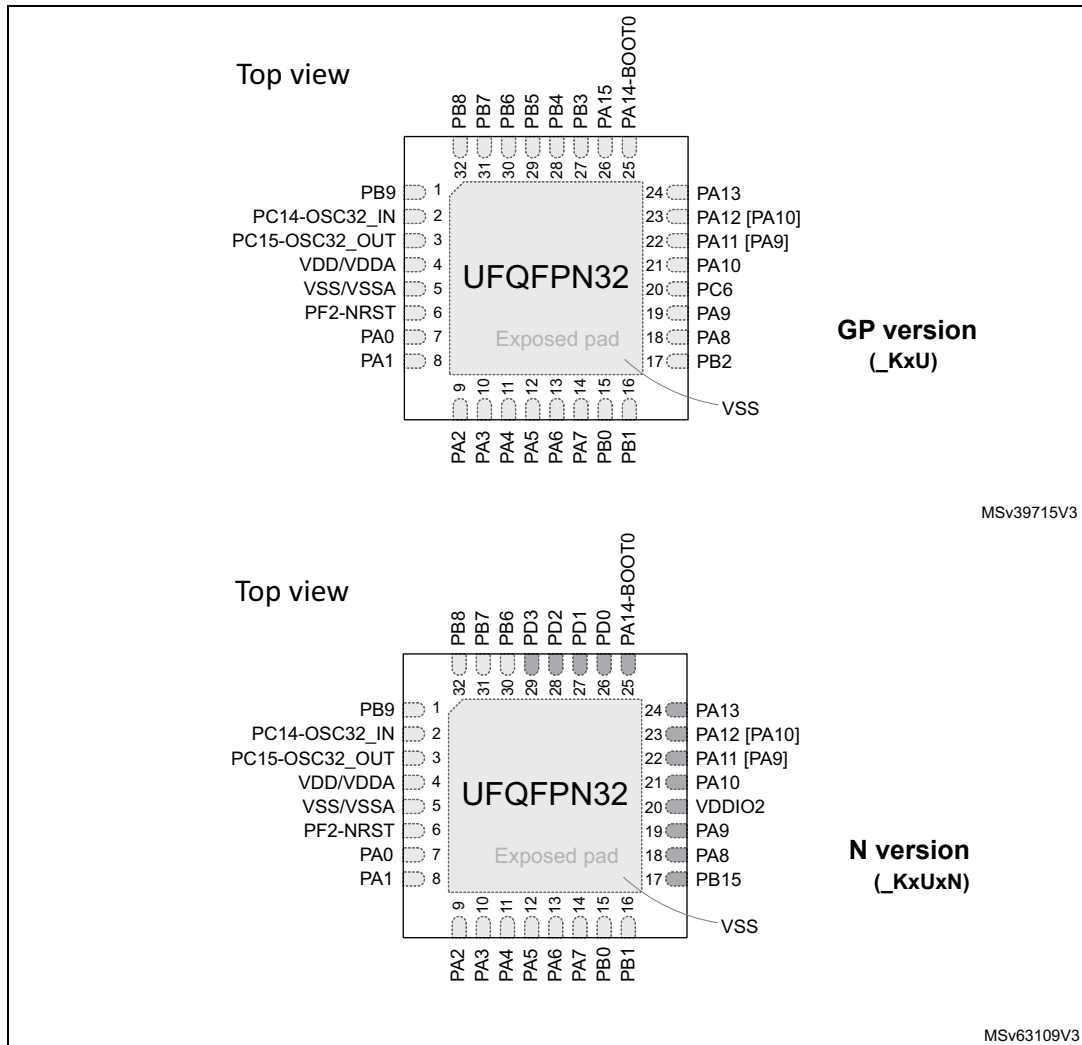

1. The I/O pads supplied by V_{DDIO2} are shown in gray.

Figure 5. STM32G0B1CxT LQFP48 pinout

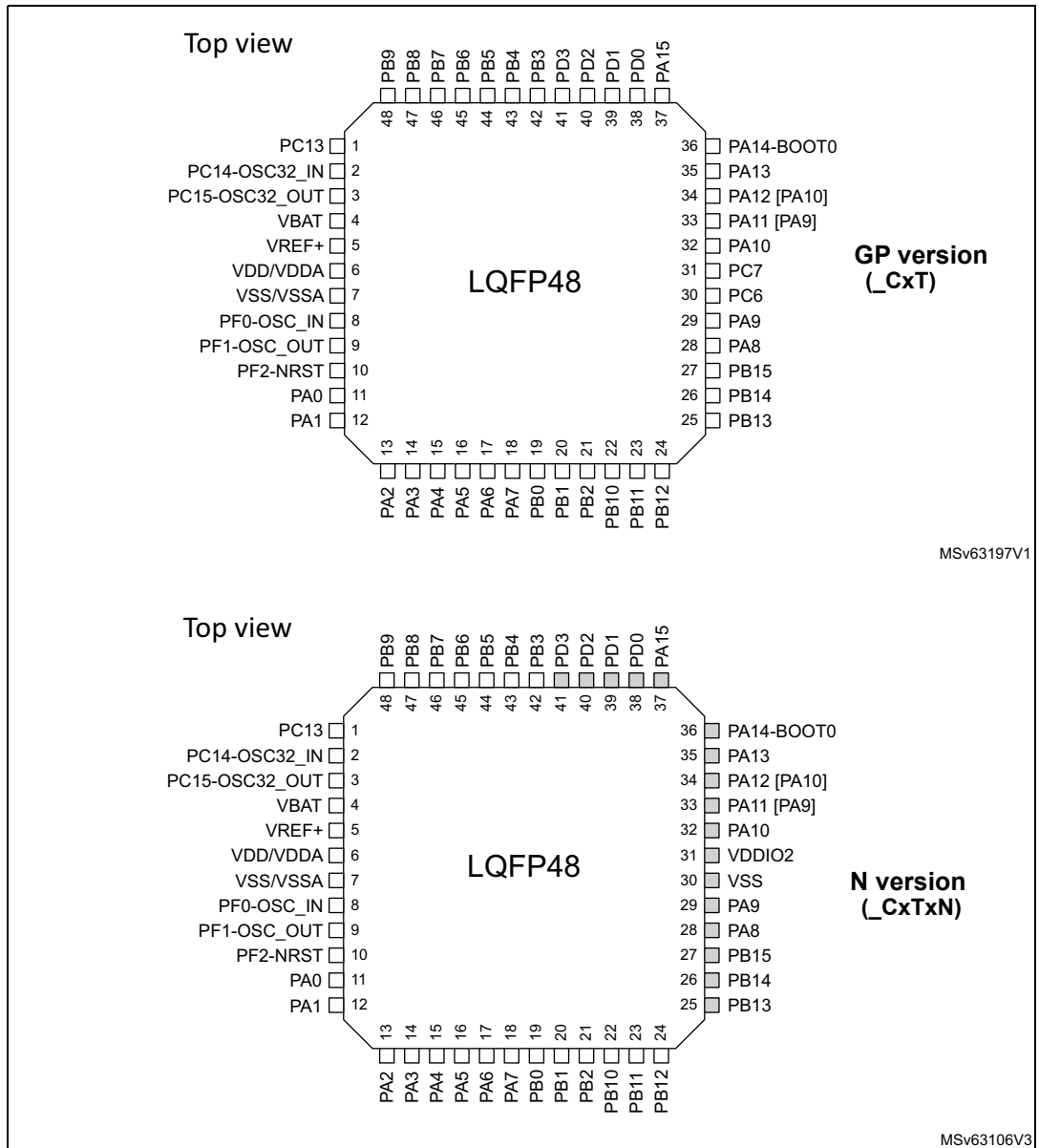

1. The I/O pins supplied by VDDIO2 are shown in gray.

Figure 6. STM32G0B1CxU UFQFPN48 pinout

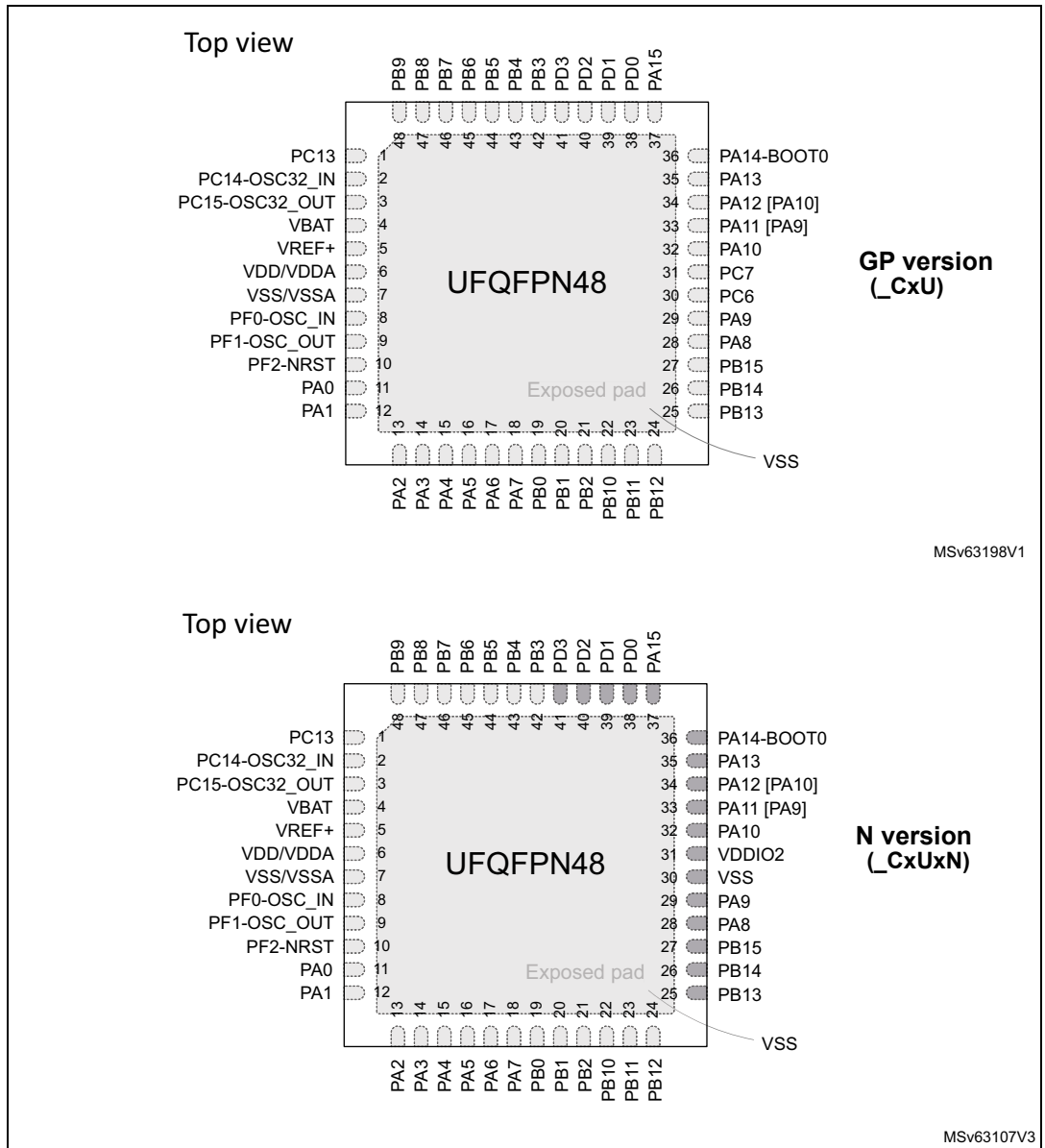

1. The I/O pads supplied by V_{DDIO2} are shown in gray.

Figure 7. STM32G0B1NxY WLCSP52 ballout

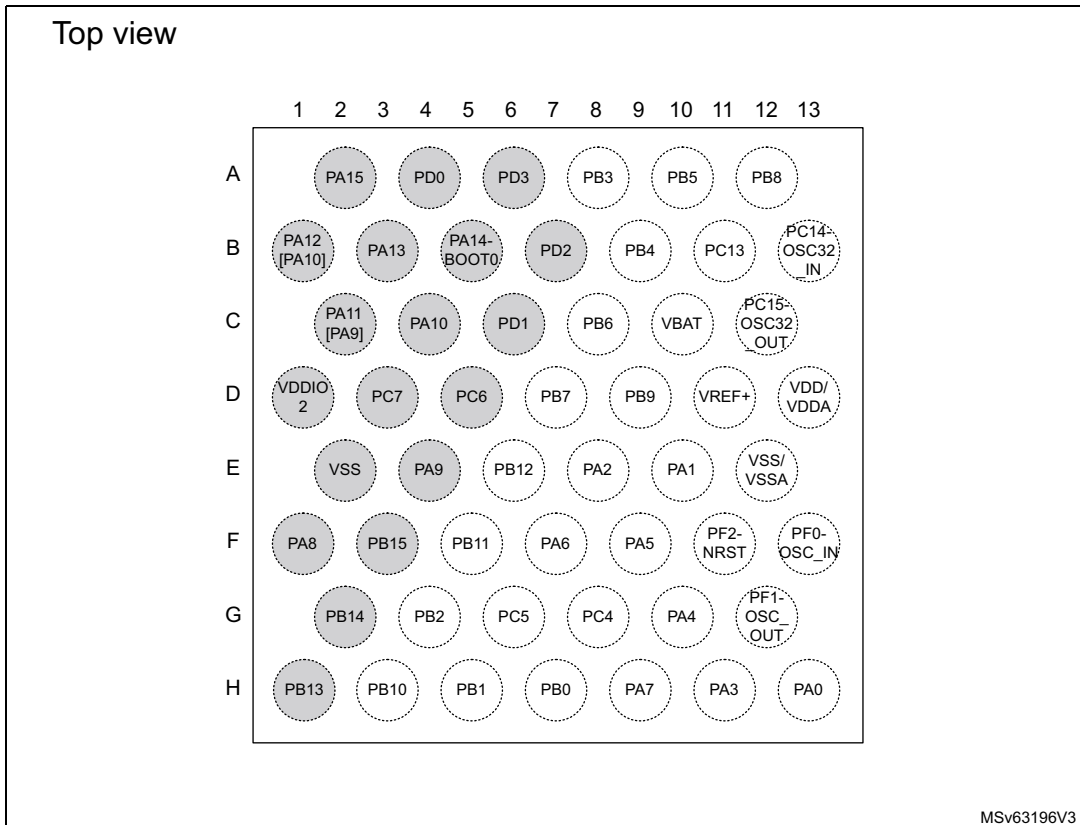

1. The I/O pads supplied by V_{DDIO2} are shown in gray.

Figure 8. STM32G0B1RxT LQFP64 pinout

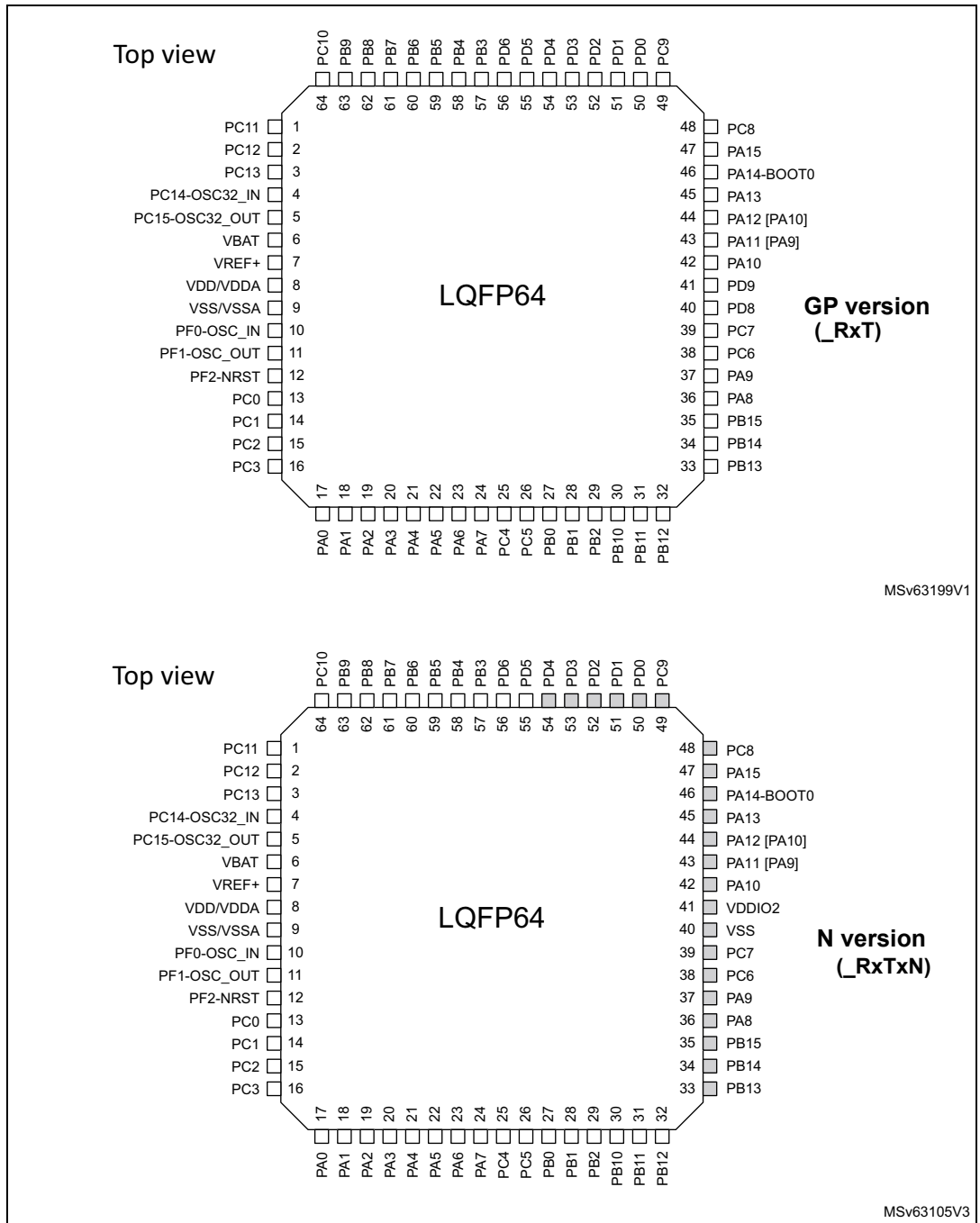

1. The I/O pins supplied by V_{DDIO2} are shown in gray.

Figure 9. STM32G0B1Rxl UFBGA64 ballout

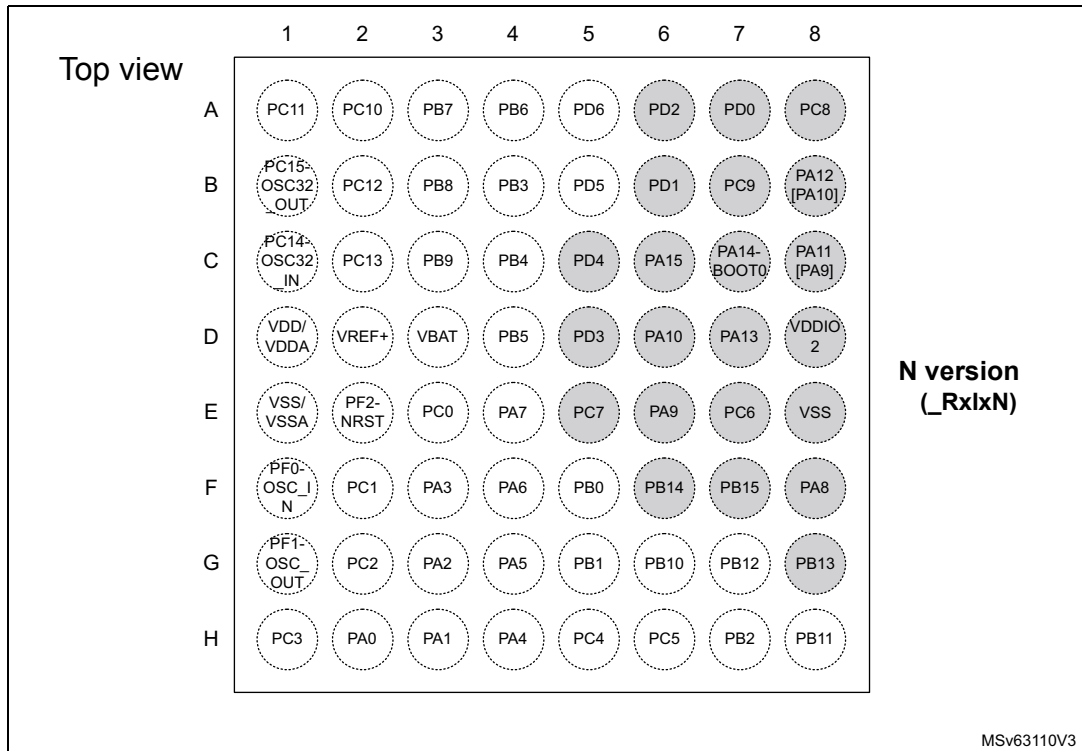

1. The I/O balls supplied by V_{DDIO2} are shown in gray.

Figure 10. STM32G0B1MxT LQFP80 pinout

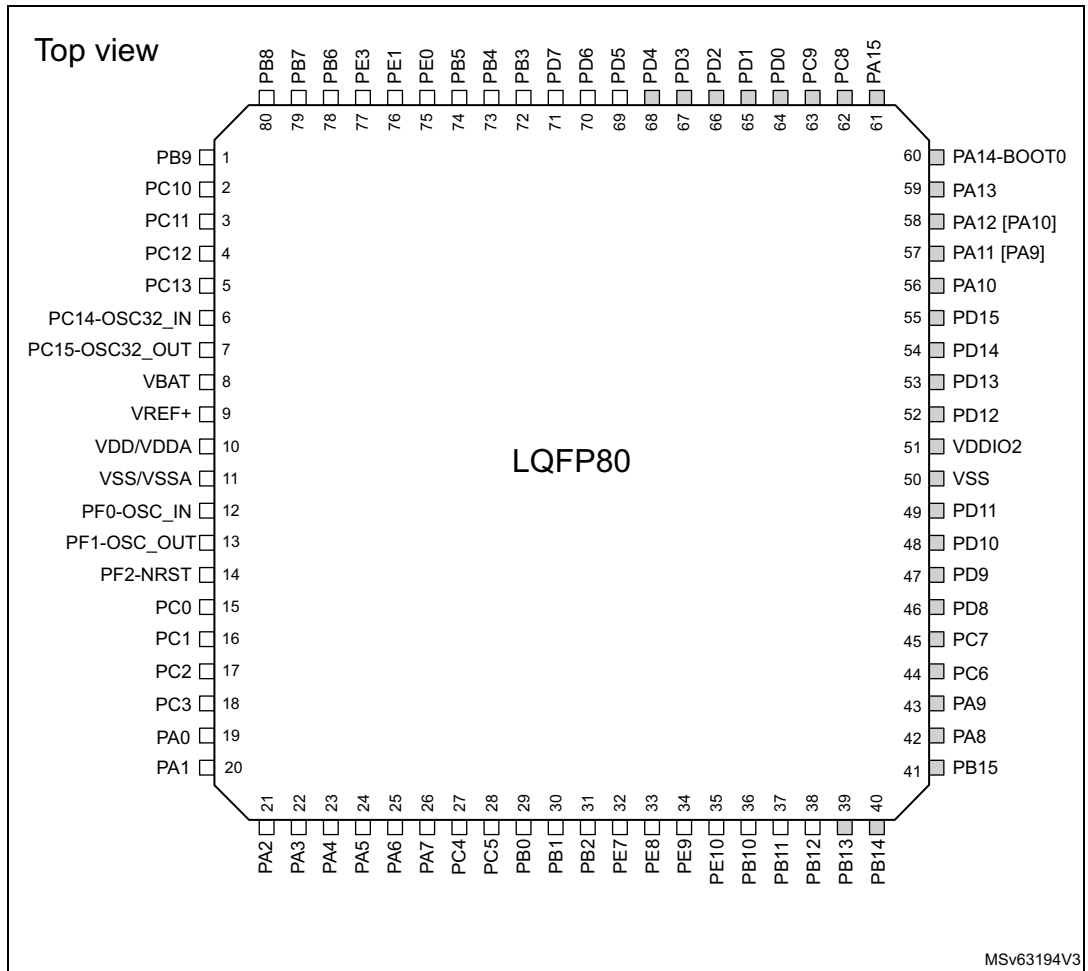

1. The I/O pins supplied by V_{DDIO2} are shown in gray.

Figure 11. STM32G0B1VxT LQFP100 pinout

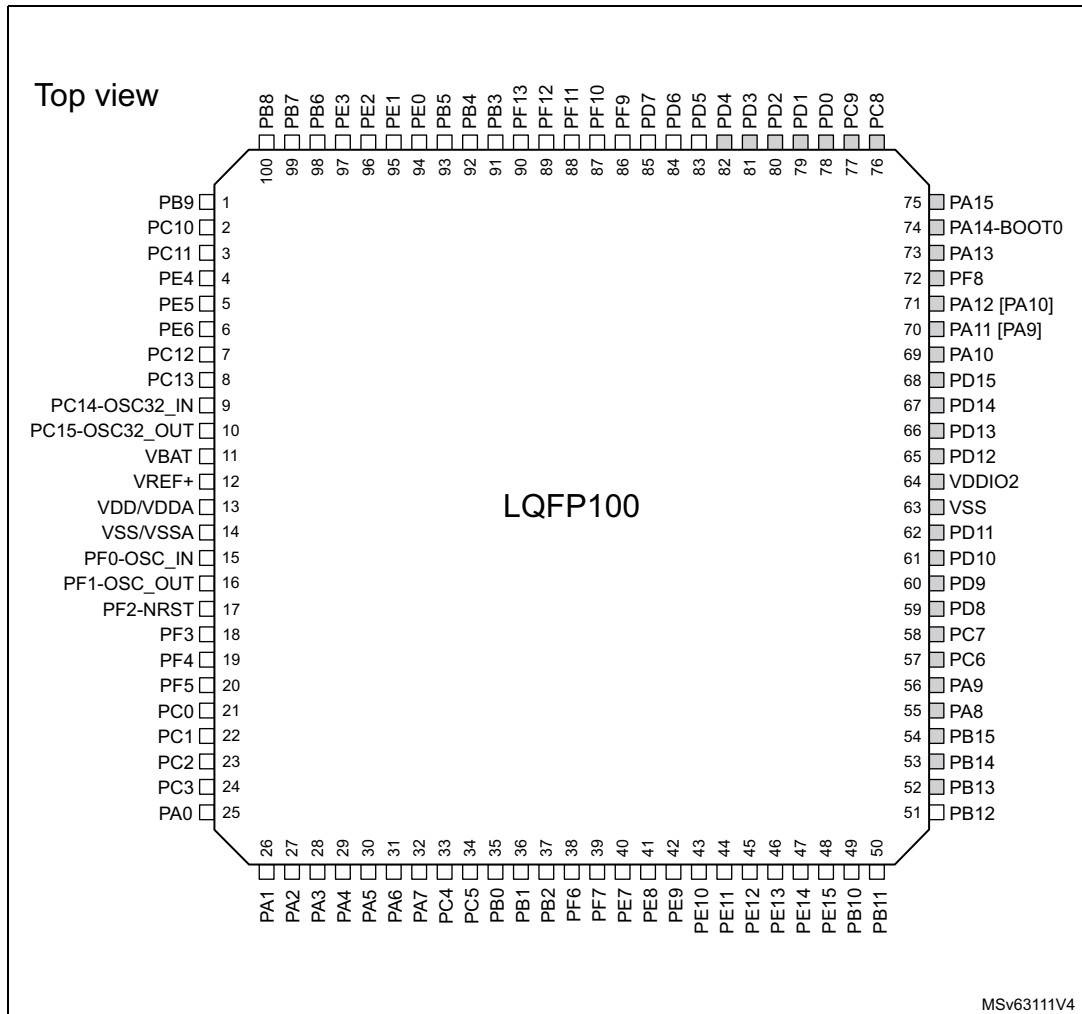

1. The I/O pins supplied by V_{DDIO2} are shown in gray.

Figure 12. STM32G0B1Vxl UFBGA100 ballout

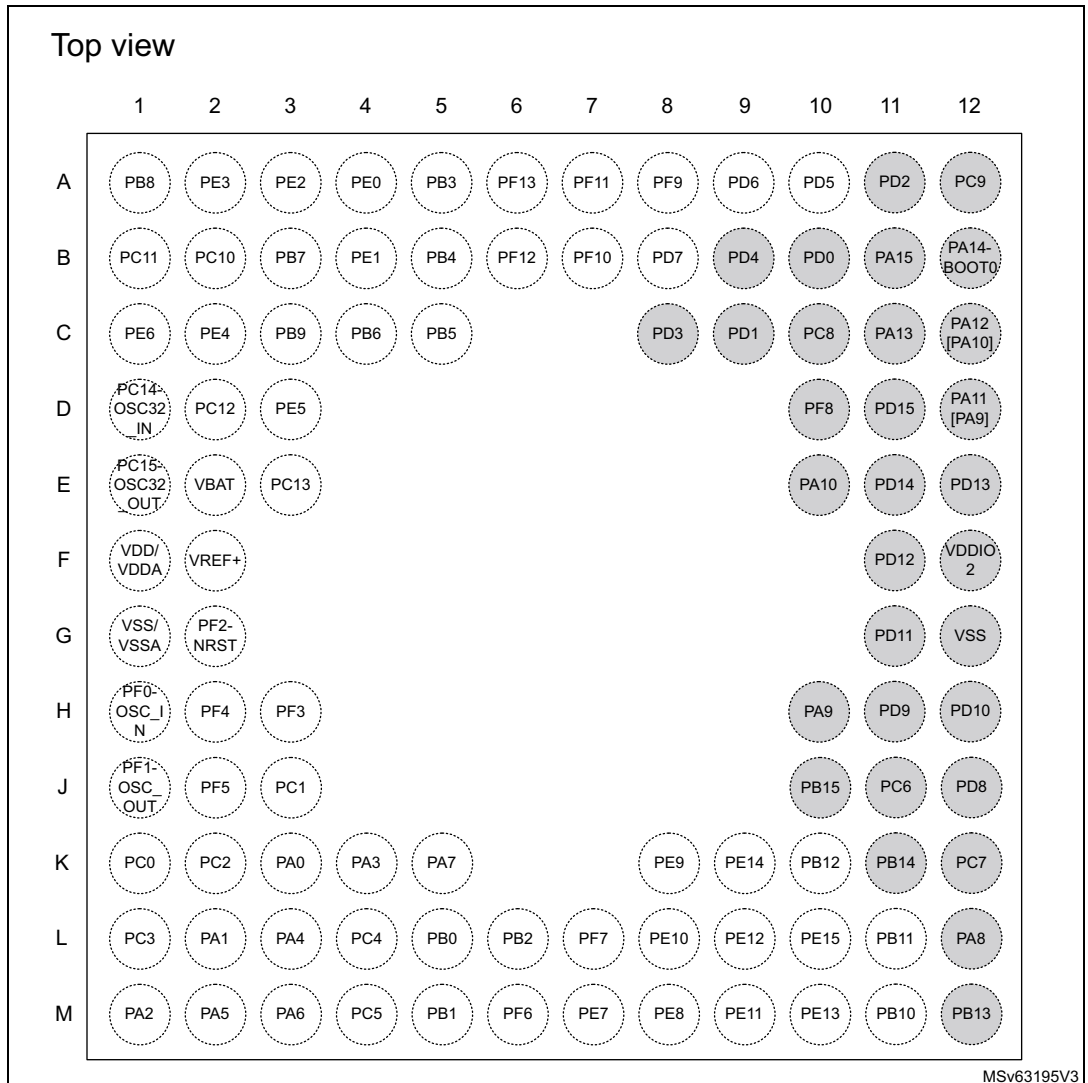

1. The I/O balls supplied by V_{DDIO2} are shown in gray.

Table 11. Terms and symbols used in *Pin assignment and description* table

Column	Symbol	Definition
Pin name	Terminal name corresponds to its by-default function at reset, unless otherwise specified in parenthesis under the pin name.	
Pin type	S	Supply pin
	I	Input only pin
	I/O	Input / output pin
I/O structure	FT	5 V tolerant I/O
	TT	3.6 V tolerant I/O
	RST	Reset pin with embedded weak pull-up resistor
	Options for TT or FT I/Os	
	_f	I/O, Fm+ capable
	_a	I/O, with analog switch function
	_c	I/O, USB Type-C PD capable
	e	I/O, with switchable diode to V{DDIOx}
	_d	I/O, USB Type-C PD Dead Battery function
	_u	I/O, with USB function
_s	I/O, supplied from VDDIO2 only	
Note	Upon reset, all I/Os are set as analog inputs, unless otherwise specified.	
Pin functions	Alternate functions	Functions selected through GPIOx_AFR registers
	Additional functions	Functions directly selected/enabled through peripheral registers



Table 12. Pin assignment and description

Pin number										Pin name	Pin type	I/O structure	Note	Alternate functions	Additional functions	
LQFP32 / UFQFPN32 - GP	LQFP32 / UFQFPN32 - N	LQFP48 / UFQFPN48 - GP	LQFP48 / UFQFPN48 - N	WLCSP52	LQFP64 - GP	LQFP64 - N	UFBGA64 - N	LQFP80	LQFP100							UFBGA100
-	-	-	-	-	64	64	A2	2	2	B2	PC10	I/O	FT	-	USART3_TX, USART4_TX, TIM1_CH3, SPI3_SCK	-
-	-	-	-	-	1	1	A1	3	3	B1	PC11	I/O	FT	-	USART3_RX, USART4_RX, TIM1_CH4, SPI3_MISO	-
-	-	-	-	-	-	-	-	-	4	C2	PE4	I/O	FT	-	TIM3_CH2	-
-	-	-	-	-	-	-	-	-	5	D3	PE5	I/O	FT	-	TIM3_CH3	-
-	-	-	-	-	-	-	-	-	6	C1	PE6	I/O	FT	-	TIM3_CH4	TAMP_IN3, WKUP3
-	-	-	-	-	2	2	B2	4	7	D2	PC12	I/O	FT	-	LPTIM1_IN1, UCPD1_FRSTX, TIM14_CH1, USART5_TX, SPI3_MOSI	-
-	-	1	1	B11	3	3	C2	5	8	E3	PC13	I/O	FT	(1)(2)	TIM1_BKIN	TAMP_IN1, RTC_TS, RTC_OUT1, WKUP2
-	-	2	2	B13	4	4	C1	6	9	D1	PC14-OSC32_IN	I/O	FT	(1)(2)	TIM1_BKIN2	OSC32_IN
2	2	-	-	-	-	-	-	-	-	-	PC14-OSC32_IN	I/O	FT	(1)(2)	TIM1_BKIN2	OSC32_IN, OSC_IN
3	3	3	3	C12	5	5	B1	7	10	E1	PC15-OSC32_OUT	I/O	FT	(1)(2)	OSC32_EN, OSC_EN, TIM15_BKIN	OSC32_OUT
-	-	4	4	C10	6	6	D3	8	11	E2	VBAT	S	-	-	-	-
-	-	5	5	D11	7	7	D2	9	12	F2	VREF+	S	-	-	-	VREFBUF_OUT
4	4	6	6	D13	8	8	D1	10	13	F1	VDD/VDDA	S	-	-	-	-
5	5	7	7	E12	9	9	E1	11	14	G1	VSS/VSSA	S	-	-	-	-
-	-	8	8	F13	10	10	F1	12	15	H1	PF0-OSC_IN	I/O	FT	-	CRS1_SYNC, EVENTOUT, TIM14_CH1	OSC_IN



Table 12. Pin assignment and description (continued)

Pin number											Pin name	Pin type	I/O structure	Note	Alternate functions	Additional functions
LQFP32 / UFQFPN32 - GP	LQFP32 / UFQFPN32 - N	LQFP48 / UFQFPN48 - GP	LQFP48 / UFQFPN48 - N	WLCSP52	LQFP64 - GP	LQFP64 - N	UFBGA64 - N	LQFP80	LQFP100	UFBGA100						
-	-	9	9	G12	11	11	G1	13	16	J1	PF1-OSC_OUT	I/O	FT	-	OSC_EN, EVENTOUT, TIM15_CH1N	OSC_OUT
6	6	10	10	F11	12	12	E2	14	17	G2	PF2-NRST	I/O	RST, FT	(3)	MCO, LPUART2_TX, LPUART2_RTS_DE	NRST
-	-	-	-	-	-	-	-	-	18	H3	PF3	I/O	FT	-	LPUART2_RX, USART6_RTS_DE_CK	-
-	-	-	-	-	-	-	-	-	19	H2	PF4	I/O	FT	-	LPUART1_TX	-
-	-	-	-	-	-	-	-	-	20	J2	PF5	I/O	FT	-	LPUART1_RX	-
-	-	-	-	-	13	13	E3	15	21	K1	PC0	I/O	FT_a	-	LPTIM1_IN1, LPUART1_RX, LPTIM2_IN1, LPUART2_TX, USART6_TX, I2C3_SCL, COMP3_OUT	COMP3_INM7
-	-	-	-	-	14	14	F2	16	22	J3	PC1	I/O	FT_a	-	LPTIM1_OUT, LPUART1_TX, TIM15_CH1, LPUART2_RX, USART6_RX, I2C3_SDA	COMP3_INP1
-	-	-	-	-	15	15	G2	17	23	K2	PC2	I/O	FT	-	LPTIM1_IN2, SPI2_MISO/I2S2_MCK, TIM15_CH2, FDCAN2_RX, COMP3_OUT	-
-	-	-	-	-	16	16	H1	18	24	L1	PC3	I/O	FT	-	LPTIM1_ETR, SPI2_MOSI/I2S2_SD, LPTIM2_ETR, FDCAN2_TX	-
7	7	11	11	H13	17	17	H2	19	25	K3	PA0	I/O	FT_a	-	SPI2_SCK/I2S2_CK, USART2_CTS, TIM2_CH1_ETR, USART4_TX, LPTIM1_OUT, UCPD2_FRSTX, COMP1_OUT	COMP1_INM8, ADC_IN0, TAMP_IN2, WKUP1
8	8	12	12	E10	18	18	H3	20	26	L2	PA1	I/O	FT_ea	-	SPI1_SCK/I2S1_CK, USART2_RTS_DE_CK, TIM2_CH2, USART4_RX, TIM15_CH1N, I2C1_SMBA, EVENTOUT	COMP1_INP2, ADC_IN1
9	9	13	13	E8	19	19	G3	21	27	M1	PA2	I/O	FT_a	-	SPI1_MOSI/I2S1_SD, USART2_TX, TIM2_CH3, UCPD1_FRSTX, TIM15_CH1, LPUART1_TX, COMP2_OUT	COMP2_INM8, ADC_IN2, WKUP4, LSCO



Table 12. Pin assignment and description (continued)

Pin number											Pin name	Pin type	I/O structure	Note	Alternate functions	Additional functions
LQFP32 / UFQFPN32 - GP	LQFP32 / UFQFPN32 - N	LQFP48 / UFQFPN48 - GP	LQFP48 / UFQFPN48 - N	WLCSP52	LQFP64 - GP	LQFP64 - N	UFBGA64 - N	LQFP80	LQFP100	UFBGA100						
10	10	14	14	H11	20	20	F3	22	28	K4	PA3	I/O	FT_ea	-	SPI2_MISO/I2S2_MCK, USART2_RX, TIM2_CH4, UCPD2_FRSTX, TIM15_CH2, LPUART1_RX, EVENTOUT	COMP2_INP2, ADC_IN3
-	-	15	15	G10	21	21	H4	23	29	L3	PA4	I/O	TT_a	-	SPI1_NSS/I2S1_WS, SPI2_MOSI/I2S2_SD, USART6_TX, TIM14_CH1, LPTIM2_OUT, UCPD2_FRSTX, EVENTOUT, SPI3_NSS	ADC_IN4, DAC1_OUT1, RTC_OUT2
11	11	-	-	-	-	-	-	-	-	-	PA4	I/O	TT_a	-	SPI1_NSS/I2S1_WS, SPI2_MOSI/I2S2_SD, USART6_TX, TIM14_CH1, LPTIM2_OUT, UCPD2_FRSTX, EVENTOUT, SPI3_NSS	ADC_IN4, DAC1_OUT1, TAMP_IN1, RTC_TS, RTC_OUT1, WKUP2
12	12	16	16	F9	22	22	G4	24	30	M2	PA5	I/O	TT_ea	-	SPI1_SCK/I2S1_CK, CEC, TIM2_CH1_ETR, USART6_RX, USART3_TX, LPTIM2_ETR, UCPD1_FRSTX, EVENTOUT	ADC_IN5, DAC1_OUT2
13	13	17	17	F7	23	23	F4	25	31	M3	PA6	I/O	FT_ea	-	SPI1_MISO/I2S1_MCK, TIM3_CH1, TIM1_BKIN, USART6_CTS, USART3_CTS, TIM16_CH1, LPUART1_CTS, COMP1_OUT, I2C2_SDA, I2C3_SDA	ADC_IN6
14	14	18	18	H9	24	24	E4	26	32	K5	PA7	I/O	FT_a	-	SPI1_MOSI/I2S1_SD, TIM3_CH2, TIM1_CH1N, USART6_RTS_DE_CK, TIM14_CH1, TIM17_CH1, UCPD1_FRSTX, COMP2_OUT, I2C2_SCL, I2C3_SCL	ADC_IN7
-	-	-	-	G8	25	25	H5	27	33	L4	PC4	I/O	FT_a	-	USART3_TX, USART1_TX, TIM2_CH1_ETR, FDCAN1_RX	COMP1_INM7, ADC_IN17
-	-	-	-	G6	26	26	H6	28	34	M4	PC5	I/O	FT_a	-	USART3_RX, USART1_RX, TIM2_CH2, FDCAN1_TX	COMP1_INP0, ADC_IN18, WKUP5



Table 12. Pin assignment and description (continued)

Pin number											Pin name	Pin type	I/O structure	Note	Alternate functions	Additional functions
LQFP32 / UFQFPN32 - GP	LQFP32 / UFQFPN32 - N	LQFP48 / UFQFPN48 - GP	LQFP48 / UFQFPN48 - N	WLCSP52	LQFP64 - GP	LQFP64 - N	UFBGA64 - N	LQFP80	LQFP100	UFBGA100						
15	15	19	19	H7	27	27	F5	29	35	L5	PB0	I/O	FT_ea	-	SPI1_NSS/I2S1_WS, TIM3_CH3, TIM1_CH2N, FDCAN2_RX, USART3_RX, LPTIM1_OUT, UCPD1_FRSTX, COMP1_OUT, USART5_TX, LPUART2_CTS	COMP3_INP0, ADC_IN8
16	16	20	20	H5	28	28	G5	30	36	M5	PB1	I/O	FT_ea	-	TIM14_CH1, TIM3_CH4, TIM1_CH3N, FDCAN2_TX, USART3_RTS_DE_CK, LPTIM2_IN1, LPUART1_RTS_DE, COMP3_OUT, USART5_RX, LPUART2_RTS_DE	COMP1_INM6, ADC_IN9
17	-	21	21	G4	29	29	H7	31	37	L6	PB2	I/O	FT_ea	-	SPI2_MISO/I2S2_MCK, MCO2, USART3_TX, LPTIM1_OUT, EVENTOUT	COMP1_INP1, COMP3_INM6, ADC_IN10
-	-	-	-	-	-	-	-	-	38	M6	PF6	I/O	FT	-	LPUART1_RTS_DE	-
-	-	-	-	-	-	-	-	-	39	L7	PF7	I/O	FT	-	LPUART1_CTS, USART5_CTS	-
-	-	-	-	-	-	-	-	32	40	M7	PE7	I/O	FT_a	-	TIM1_ETR, USART5_RTS_DE_CK	COMP3_INP2
-	-	-	-	-	-	-	-	33	41	M8	PE8	I/O	FT_a	-	USART4_TX, TIM1_CH1N	COMP3_INM8
-	-	-	-	-	-	-	-	34	42	K8	PE9	I/O	FT	-	USART4_RX, TIM1_CH1	-
-	-	-	-	-	-	-	-	35	43	L8	PE10	I/O	FT	-	TIM1_CH2N, USART5_TX	-
-	-	-	-	-	-	-	-	-	44	M9	PE11	I/O	FT	-	TIM1_CH2, USART5_RX	-
-	-	-	-	-	-	-	-	-	45	L9	PE12	I/O	FT	-	SPI1_NSS/I2S1_WS, TIM1_CH3N	-
-	-	-	-	-	-	-	-	-	46	M10	PE13	I/O	FT	-	SPI1_SCK/I2S1_CK, TIM1_CH3	-
-	-	-	-	-	-	-	-	-	47	K9	PE14	I/O	FT	-	SPI1_MISO/I2S1_MCK, TIM1_CH4, TIM1_BKIN2	-
-	-	-	-	-	-	-	-	-	48	L10	PE15	I/O	FT	-	SPI1_MOSI/I2S1_SD, TIM1_BKIN	-



Table 12. Pin assignment and description (continued)

Pin number											Pin name	Pin type	I/O structure	Note	Alternate functions	Additional functions
LQFP32 / UFQFPN32 - GP	LQFP32 / UFQFPN32 - N	LQFP48 / UFQFPN48 - GP	LQFP48 / UFQFPN48 - N	WLCSP52	LQFP64 - GP	LQFP64 - N	UFBGA64 - N	LQFP80	LQFP100	UFBGA100						
-	-	22	22	H3	30	30	G6	36	49	M11	PB10	I/O	FT_fa	-	CEC, LPUART1_RX, TIM2_CH3, USART3_TX, SPI2_SCK/I2S2_CK, I2C2_SCL, COMP1_OUT	ADC_IN11
-	-	23	23	F5	31	31	H8	37	50	L11	PB11	I/O	FT_fa	-	SPI2_MOSI/I2S2_SD, LPUART1_TX, TIM2_CH4, USART3_RX, I2C2_SDA, COMP2_OUT	ADC_IN15
-	-	24	24	E6	32	32	G7	38	51	K10	PB12	I/O	FT_fa	-	SPI2_NSS/I2S2_WS, LPUART1_RTS_DE, TIM1_BKIN, FDCAN2_RX, TIM15_BKIN, UCPD2_FRSTX, EVENTOUT, I2C2_SMBA	ADC_IN16
-	-	25	25	H1	33	33	G8	39	52	M12	PB13	I/O	FT_fs	-	SPI2_SCK/I2S2_CK, LPUART1_CTS, TIM1_CH1N, FDCAN2_TX, USART3_CTS, TIM15_CH1N, I2C2_SCL, EVENTOUT	-
-	-	26	26	G2	34	34	F6	40	53	K11	PB14	I/O	FT_fs	-	SPI2_MISO/I2S2_MCK, UCPD1_FRSTX, TIM1_CH2N, USART3_RTS_DE_CK, TIM15_CH1, I2C2_SDA, EVENTOUT, USART6_RTS_DE_CK	-
-	17	27	27	F3	35	35	F7	41	54	J10	PB15	I/O	FT_fcs	(4)	SPI2_MOSI/I2S2_SD, TIM1_CH3N, TIM15_CH1N, TIM15_CH2, EVENTOUT, USART6_CTS	UCPD1_CC2, RTC_REFIN
18	18	28	28	F1	36	36	F8	42	55	L12	PA8	I/O	FT_fcs	(4)	MCO, SPI2_NSS/I2S2_WS, TIM1_CH1, CRS1_SYNC, LPTIM2_OUT, EVENTOUT, I2C2_SMBA	UCPD1_CC1
19	19	29	29	E4	37	37	E6	43	56	H10	PA9	I/O	FT_fds	(4)	MCO, USART1_TX, TIM1_CH2, SPI2_MISO/I2S2_MCK, TIM15_BKIN, I2C1_SCL, EVENTOUT, I2C2_SCL	UCPD1_DBCC1
20	-	30	-	D5	38	38	E7	44	57	J11	PC6	I/O	FT_s	-	UCPD1_FRSTX, TIM3_CH1, TIM2_CH3, LPUART2_TX	-
-	-	31	-	D3	39	39	E5	45	58	K12	PC7	I/O	FT_s	-	UCPD2_FRSTX, TIM3_CH2, TIM2_CH4, LPUART2_RX	-



Table 12. Pin assignment and description (continued)

Pin number										Pin name	Pin type	I/O structure	Note	Alternate functions	Additional functions	
LQFP32 / UFQFPN32 - GP	LQFP32 / UFQFPN32 - N	LQFP48 / UFQFPN48 - GP	LQFP48 / UFQFPN48 - N	WLCSP52	LQFP64 - GP	LQFP64 - N	UFBGA64 - N	LQFP80	LQFP100							UFBGA100
-	-	-	-	-	40	-	-	46	59	J12	PD8	I/O	FT_s	-	USART3_TX, SPI1_SCK/I2S1_CK, LPTIM1_OUT	-
-	-	-	-	-	41	-	-	47	60	H11	PD9	I/O	FT_s	-	USART3_RX, SPI1_NSS/I2S1_WS, TIM1_BKIN2	-
-	-	-	-	-	-	-	-	48	61	H12	PD10	I/O	FT_s	-	MCO	-
-	-	-	-	-	-	-	-	49	62	G11	PD11	I/O	FT_s	-	USART3_CTS, LPTIM2_ETR	-
-	-	-	30	E2	-	40	E8	50	63	G12	VSS	S	-	-	-	-
-	20	-	31	D1	-	41	D8	51	64	F12	VDDIO2	S	-	-	-	-
-	-	-	-	-	-	-	-	52	65	F11	PD12	I/O	FT_s	-	USART3_RTS_DE_CK, LPTIM2_IN1, TIM4_CH1, FDCAN1_RX	-
-	-	-	-	-	-	-	-	53	66	E12	PD13	I/O	FT_s	-	LPTIM2_OUT, TIM4_CH2, FDCAN1_TX	-
-	-	-	-	-	-	-	-	54	67	E11	PD14	I/O	FT_s	-	LPUART2_CTS, TIM4_CH3, FDCAN2_RX	-
-	-	-	-	-	-	-	-	55	68	D11	PD15	I/O	FT_s	-	CRS1_SYNC, LPUART2_RTS_DE, TIM4_CH4, FDCAN2_TX	-
21	21	32	32	C4	42	42	D6	56	69	E10	PA10	I/O	FT_fds	(4)	SPI2_MOSI/I2S2_SD, USART1_RX, TIM1_CH3, MCO2, TIM17_BKIN, I2C1_SDA, EVENTOUT, I2C2_SDA	UCPD1_DBCC2
22	22	33	33	C2	43	43	C8	57	70	D12	PA11 [PA9]	I/O	FT_fus	(5)	SPI1_MISO/I2S1_MCK, USART1_CTS, TIM1_CH4, FDCAN1_RX, TIM1_BKIN2, I2C2_SCL, COMP1_OUT	USB_DM
23	23	34	34	B1	44	44	B8	58	71	C12	PA12 [PA10]	I/O	FT_fus	(5)	SPI1_MOSI/I2S1_SD, USART1_RTS_DE_CK, TIM1_ETR, FDCAN1_TX, I2S_CKIN, I2C2_SDA, COMP2_OUT	USB_DP
-	-	-	-	-	-	-	-	-	72	D10	PF8	I/O	FT_s	-	-	-



Table 12. Pin assignment and description (continued)

Pin number											Pin name	Pin type	I/O structure	Note	Alternate functions	Additional functions
LQFP32 / UFQFPN32 - GP	LQFP32 / UFQFPN32 - N	LQFP48 / UFQFPN48 - GP	LQFP48 / UFQFPN48 - N	WLCSP52	LQFP64 - GP	LQFP64 - N	UFBGA64 - N	LQFP80	LQFP100	UFBGA100						
24	24	35	35	B3	45	45	D7	59	73	C11	PA13	I/O	FT_es	(6)	SWDIO, IR_OUT, USB_NOE, EVENTOUT, LPUART2_RX	-
25	25	36	36	B5	46	46	C7	60	74	B12	PA14-BOOT0	I/O	FT_s	(6)	SWCLK, USART2_TX, EVENTOUT, LPUART2_TX	BOOT0
26	-	37	37	A2	47	47	C6	61	75	B11	PA15	I/O	FT_s	-	SPI1_NSS/I2S1_WS, USART2_RX, TIM2_CH1_ETR, MCO2, USART4_RTS_DE_CK, USART3_RTS_DE_CK, USB_NOE, EVENTOUT, I2C2_SMBA, SPI3_NSS	-
-	-	-	-	-	48	48	A8	62	76	C10	PC8	I/O	FT_s	-	UCPD2_FRSTX, TIM3_CH3, TIM1_CH1, LPUART2_CTS	-
-	-	-	-	-	49	49	B7	63	77	A12	PC9	I/O	FT_s	-	I2S_CKIN, TIM3_CH4, TIM1_CH2, LPUART2_RTS_DE, USB_NOE	-
-	26	38	38	A4	50	50	A7	64	78	B10	PD0	I/O	FT_cs	(4)	EVENTOUT, SPI2_NSS/I2S2_WS, TIM16_CH1, FDCAN1_RX	UCPD2_CC1
-	27	39	39	C6	51	51	B6	65	79	C9	PD1	I/O	FT_ds	(4)	EVENTOUT, SPI2_SCK/I2S2_CK, TIM17_CH1, FDCAN1_TX	UCPD2_DBCC1
-	28	40	40	B7	52	52	A6	66	80	A11	PD2	I/O	FT_cs	(4)	USART3_RTS_DE_CK, TIM3_ETR, TIM1_CH1N, USART5_RX	UCPD2_CC2
-	29	41	41	A6	53	53	D5	67	81	C8	PD3	I/O	FT_ds	(4)	USART2_CTS, SPI2_MISO/I2S2_MCK, TIM1_CH2N, USART5_TX	UCPD2_DBCC2
-	-	-	-	-	54	54	C5	68	82	B9	PD4	I/O	FT_s	-	USART2_RTS_DE_CK, SPI2_MOSI/I2S2_SD, TIM1_CH3N, USART5_RTS_DE_CK	-
-	-	-	-	-	55	55	B5	69	83	A10	PD5	I/O	FT	-	USART2_TX, SPI1_MISO/I2S1_MCK, TIM1_BKIN, USART5_CTS	-
-	-	-	-	-	56	56	A5	70	84	A9	PD6	I/O	FT	-	USART2_RX, SPI1_MOSI/I2S1_SD, LPTIM2_OUT	-



Table 12. Pin assignment and description (continued)

Pin number											Pin name	Pin type	I/O structure	Note	Alternate functions	Additional functions
LQFP32 / UFQFPN32 - GP	LQFP32 / UFQFPN32 - N	LQFP48 / UFQFPN48 - GP	LQFP48 / UFQFPN48 - N	WLCSP52	LQFP64 - GP	LQFP64 - N	UFBGA64 - N	LQFP80	LQFP100	UFBGA100						
-	-	-	-	-	-	-	-	71	85	B8	PD7	I/O	FT	-	MCO2	-
-	-	-	-	-	-	-	-	-	86	A8	PF9	I/O	FT	-	USART6_TX	-
-	-	-	-	-	-	-	-	-	87	B7	PF10	I/O	FT	-	USART6_RX	-
-	-	-	-	-	-	-	-	-	88	A7	PF11	I/O	FT	-	USART6_RTS_DE_CK	-
-	-	-	-	-	-	-	-	-	89	B6	PF12	I/O	FT	-	TIM15_CH1, USART6_CTS	-
-	-	-	-	-	-	-	-	-	90	A6	PF13	I/O	FT	-	TIM15_CH2	-
27	-	42	42	A8	57	57	B4	72	91	A5	PB3	I/O	FT_a	-	SPI1_SCK/I2S1_CK, TIM1_CH2, TIM2_CH2, USART5_TX, USART1_RTS_DE_CK, I2C3_SCL, EVENTOUT, I2C2_SCL, SPI3_SCK	COMP2_INM6
28	-	43	43	B9	58	58	C4	73	92	B5	PB4	I/O	FT_a	-	SPI1_MISO/I2S1_MCK, TIM3_CH1, USART5_RX, USART1_CTS, TIM17_BKIN, I2C3_SDA, EVENTOUT, I2C2_SDA, SPI3_MISO	COMP2_INP0
29	-	44	44	A10	59	59	D4	74	93	C5	PB5	I/O	FT	-	SPI1_MOSI/I2S1_SD, TIM3_CH2, TIM16_BKIN, FDCAN2_RX, LPTIM1_IN1, I2C1_SMBA, COMP2_OUT, USART5_RTS_DE_CK, SPI3_MOSI	WKUP6
-	-	-	-	-	-	-	-	75	94	A4	PE0	I/O	FT	-	TIM16_CH1, EVENTOUT, TIM4_ETR	-
-	-	-	-	-	-	-	-	76	95	B4	PE1	I/O	FT	-	TIM17_CH1, EVENTOUT	-
-	-	-	-	-	-	-	-	-	96	A3	PE2	I/O	FT	-	TIM3_ETR	-
-	-	-	-	-	-	-	-	77	97	A2	PE3	I/O	FT	-	TIM3_CH1	-

Table 12. Pin assignment and description (continued)

Pin number										Pin name	Pin type	I/O structure	Note	Alternate functions	Additional functions	
LQFP32 / UFQFPN32 - GP	LQFP32 / UFQFPN32 - N	LQFP48 / UFQFPN48 - GP	LQFP48 / UFQFPN48 - N	WLCSP52	LQFP64 - GP	LQFP64 - N	UFPGA64 - N	LQFP80	LQFP100							UFPGA100
30	30	45	45	C8	60	60	A4	78	98	C4	PB6	I/O	FT_fa	-	USART1_TX, TIM1_CH3, TIM16_CH1N, FDCAN2_TX, SPI2_MISO/I2S2_MCK, LPTIM1_ETR, I2C1_SCL, EVENTOUT, USART5_CTS, TIM4_CH1, LPUART2_TX	COMP2_INP1
31	31	46	46	D7	61	61	A3	79	99	B3	PB7	I/O	FT_fa	-	USART1_RX, SPI2_MOSI/I2S2_SD, TIM17_CH1N, USART4_CTS, LPTIM1_IN2, I2C1_SDA, EVENTOUT, TIM4_CH2, LPUART2_RX	COMP2_INM7, PVD_IN
32	32	47	47	A12	62	62	B3	80	100	A1	PB8	I/O	FT_f	-	CEC, SPI2_SCK/I2S2_CK, TIM16_CH1, FDCAN1_RX, USART3_TX, TIM15_BKIN, I2C1_SCL, EVENTOUT, USART6_TX, TIM4_CH3	-
1	1	48	48	D9	63	63	C3	1	1	C3	PB9	I/O	FT_f	-	IR_OUT, UCPD2_FRSTX, TIM17_CH1, FDCAN1_TX, USART3_RX, SPI2_NSS/I2S2_WS, I2C1_SDA, EVENTOUT, USART6_RX, TIM4_CH4	-

- PC13, PC14 and PC15 are supplied through the power switch. Since the switch only provides a limited amount of current (3 mA), the use of GPIOs PC13 to PC15 in output mode is limited:
 - The speed should not exceed 2 MHz with a maximum load of 30 pF
 - These GPIOs can be used as current sinks but not as current sources.
- After an RTC domain power-up, PC13, PC14 and PC15 operate as GPIOs. Their function then depends on the content of the RTC registers. The RTC registers are not reset upon system reset. For details on how to manage these GPIOs, refer to the RTC domain and RTC register descriptions in the RM0444 reference manual.
- RST I/O structure when the PF2-NRST pin is configured as reset (input or input/output mode), FT I/O structure when the PF2-NRST pin is configured as GPIO.
- Upon reset, a pull-down resistor might be present on PA8, PB15, PD0, or PD2 depending on voltage level on PA9, PA10, PD1, and PD3, respectively. In order to disable this resistor, strobe the UCPDx_STROBE bits in SYSCFG_CFGR1 register during start-up sequence.
- Pins PA9/PA10 can be remapped in place of pins PA11/PA12 (default mapping), using SYSCFG_CFGR1 register.
- Upon reset, these pins are configured as SW debug alternate functions, and the internal pull-up on PA13 pin and the internal pull-down on PA14 pin are activated.



Table 13. Port A alternate function mapping (AF0 to AF7)

Port	AF0	AF1	AF2	AF3	AF4	AF5	AF6	AF7
PA0	SPI2_SCK/ I2S2_CK	USART2_CTS	TIM2_CH1_ETR	-	USART4_TX	LPTIM1_OUT	UCPD2_FRSTX	COMP1_OUT
PA1	SPI1_SCK/ I2S1_CK	USART2_RTS _DE_CK	TIM2_CH2	-	USART4_RX	TIM15_CH1N	I2C1_SMBA	EVENTOUT
PA2	SPI1_MOSI/ I2S1_SD	USART2_TX	TIM2_CH3	-	UCPD1_FRSTX	TIM15_CH1	LPUART1_TX	COMP2_OUT
PA3	SPI2_MISO/ I2S2_MCK	USART2_RX	TIM2_CH4	-	UCPD2_FRSTX	TIM15_CH2	LPUART1_RX	EVENTOUT
PA4	SPI1_NSS/ I2S1_WS	SPI2_MOSI/ I2S2_SD	-	USART6_TX	TIM14_CH1	LPTIM2_OUT	UCPD2_FRSTX	EVENTOUT
PA5	SPI1_SCK/ I2S1_CK	CEC	TIM2_CH1_ETR	USART6_RX	USART3_TX	LPTIM2_ETR	UCPD1_FRSTX	EVENTOUT
PA6	SPI1_MISO/ I2S1_MCK	TIM3_CH1	TIM1_BKIN	USART6_CTS	USART3_CTS	TIM16_CH1	LPUART1_CTS	COMP1_OUT
PA7	SPI1_MOSI/ I2S1_SD	TIM3_CH2	TIM1_CH1N	USART6_RTS _DE_CK	TIM14_CH1	TIM17_CH1	UCPD1_FRSTX	COMP2_OUT
PA8	MCO	SPI2_NSS/ I2S2_WS	TIM1_CH1	-	CRS1_SYNC	LPTIM2_OUT	-	EVENTOUT
PA9	MCO	USART1_TX	TIM1_CH2	-	SPI2_MISO/ I2S2_MCK	TIM15_BKIN	I2C1_SCL	EVENTOUT
PA10	SPI2_MOSI/ I2S2_SD	USART1_RX	TIM1_CH3	MCO2	-	TIM17_BKIN	I2C1_SDA	EVENTOUT
PA11	SPI1_MISO/ I2S1_MCK	USART1_CTS	TIM1_CH4	FDCAN1_RX	-	TIM1_BKIN2	I2C2_SCL	COMP1_OUT
PA12	SPI1_MOSI/ I2S1_SD	USART1_RTS _DE_CK	TIM1_ETR	FDCAN1_TX	-	I2S_CKIN	I2C2_SDA	COMP2_OUT
PA13	SWDIO	IR_OUT	USB_NOE	-	-	-	-	EVENTOUT
PA14	SWCLK	USART2_TX	-	-	-	-	-	EVENTOUT
PA15	SPI1_NSS/ I2S1_WS	USART2_RX	TIM2_CH1_ETR	MCO2	USART4_RTS _DE_CK	USART3_RTS _DE_CK	USB_NOE	EVENTOUT



Table 14. Port A alternate function mapping (AF8 to AF15)

Port	AF8	AF9	AF10	AF11	AF12	AF13	AF14	AF15
PA0	-	-	-	-	-	-	-	-
PA1	-	-	-	-	-	-	-	-
PA2	-	-	-	-	-	-	-	-
PA3	-	-	-	-	-	-	-	-
PA4	-	SPI3_NSS	-	-	-	-	-	-
PA5	-	-	-	-	-	-	-	-
PA6	I2C2_SDA	I2C3_SDA	-	-	-	-	-	-
PA7	I2C2_SCL	I2C3_SCL	-	-	-	-	-	-
PA8	I2C2_SMBA	-	-	-	-	-	-	-
PA9	I2C2_SCL	-	-	-	-	-	-	-
PA10	I2C2_SDA	-	-	-	-	-	-	-
PA11	-	-	-	-	-	-	-	-
PA12	-	-	-	-	-	-	-	-
PA13	-	-	LPUART2_RX	-	-	-	-	-
PA14	-	-	LPUART2_TX	-	-	-	-	-
PA15	I2C2_SMBA	SPI3_NSS	-	-	-	-	-	-



Table 15. Port B alternate function mapping (AF0 to AF7)

Port	AF0	AF1	AF2	AF3	AF4	AF5	AF6	AF7
PB0	SPI1_NSS/ I2S1_WS	TIM3_CH3	TIM1_CH2N	FDCAN2_RX	USART3_RX	LPTIM1_OUT	UCPD1_FRSTX	COMP1_OUT
PB1	TIM14_CH1	TIM3_CH4	TIM1_CH3N	FDCAN2_TX	USART3_RTS _DE_CK	LPTIM2_IN1	LPUART1_RTS _DE	COMP3_OUT
PB2	-	SPI2_MISO/ I2S2_MCK	-	MCO2	USART3_TX	LPTIM1_OUT	-	EVENTOUT
PB3	SPI1_SCK/ I2S1_CK	TIM1_CH2	TIM2_CH2	USART5_TX	USART1_RTS _DE_CK	-	I2C3_SCL	EVENTOUT
PB4	SPI1_MISO/ I2S1_MCK	TIM3_CH1	-	USART5_RX	USART1_CTS	TIM17_BKIN	I2C3_SDA	EVENTOUT
PB5	SPI1_MOSI/ I2S1_SD	TIM3_CH2	TIM16_BKIN	FDCAN2_RX	-	LPTIM1_IN1	I2C1_SMBA	COMP2_OUT
PB6	USART1_TX	TIM1_CH3	TIM16_CH1N	FDCAN2_TX	SPI2_MISO/ I2S2_MCK	LPTIM1_ETR	I2C1_SCL	EVENTOUT
PB7	USART1_RX	SPI2_MOSI/ I2S2_SD	TIM17_CH1N	-	USART4_CTS	LPTIM1_IN2	I2C1_SDA	EVENTOUT
PB8	CEC	SPI2_SCK/ I2S2_CK	TIM16_CH1	FDCAN1_RX	USART3_TX	TIM15_BKIN	I2C1_SCL	EVENTOUT
PB9	IR_OUT	UCPD2_FRSTX	TIM17_CH1	FDCAN1_TX	USART3_RX	SPI2_NSS/ I2S2_WS	I2C1_SDA	EVENTOUT
PB10	CEC	LPUART1_RX	TIM2_CH3	-	USART3_TX	SPI2_SCK/ I2S2_CK	I2C2_SCL	COMP1_OUT
PB11	SPI2_MOSI/ I2S2_SD	LPUART1_TX	TIM2_CH4	-	USART3_RX	-	I2C2_SDA	COMP2_OUT
PB12	SPI2_NSS/ I2S2_WS	LPUART1_RTS _DE	TIM1_BKIN	FDCAN2_RX	-	TIM15_BKIN	UCPD2_FRSTX	EVENTOUT
PB13	SPI2_SCK/ I2S2_CK	LPUART1_CTS	TIM1_CH1N	FDCAN2_TX	USART3_CTS	TIM15_CH1N	I2C2_SCL	EVENTOUT

**Table 15. Port B alternate function mapping (AF0 to AF7) (continued)**

Port	AF0	AF1	AF2	AF3	AF4	AF5	AF6	AF7
PB14	SPI2_MISO/ I2S2_MCK	UCPD1_FRSTX	TIM1_CH2N	-	USART3_RTS _DE_CK	TIM15_CH1	I2C2_SDA	EVENTOUT
PB15	SPI2_MOSI/ I2S2_SD	-	TIM1_CH3N	-	TIM15_CH1N	TIM15_CH2	-	EVENTOUT

Table 16. Port B alternate function mapping (AF8 to AF15)

Port	AF8	AF9	AF10	AF11	AF12	AF13	AF14	AF15
PB0	USART5_TX	-	LPUART2_CTS	-	-	-	-	-
PB1	USART5_RX	-	LPUART2_RTS _DE	-	-	-	-	-
PB2	-	-	-	-	-	-	-	-
PB3	I2C2_SCL	SPI3_SCK	-	-	-	-	-	-
PB4	I2C2_SDA	SPI3_MISO	-	-	-	-	-	-
PB5	USART5_RTS _DE_CK	SPI3_MOSI	-	-	-	-	-	-
PB6	USART5_CTS	TIM4_CH1	LPUART2_TX	-	-	-	-	-
PB7	-	TIM4_CH2	LPUART2_RX	-	-	-	-	-
PB8	USART6_TX	TIM4_CH3	-	-	-	-	-	-
PB9	USART6_RX	TIM4_CH4	-	-	-	-	-	-
PB10	-	-	-	-	-	-	-	-
PB11	-	-	-	-	-	-	-	-
PB12	I2C2_SMBA	-	-	-	-	-	-	-
PB13	-	-	-	-	-	-	-	-
PB14	USART6_RTS _DE_CK	-	-	-	-	-	-	-
PB15	USART6_CTS	-	-	-	-	-	-	-



Table 17. Port C alternate function mapping

Port	AF0	AF1	AF2	AF3	AF4	AF5	AF6	AF7
PC0	LPTIM1_IN1	LPUART1_RX	LPTIM2_IN1	LPUART2_TX	USART6_TX	-	I2C3_SCL	COMP3_OUT
PC1	LPTIM1_OUT	LPUART1_TX	TIM15_CH1	LPUART2_RX	USART6_RX	-	I2C3_SDA	-
PC2	LPTIM1_IN2	SPI2_MISO/ I2S2_MCK	TIM15_CH2	FDCAN2_RX	-	-	-	COMP3_OUT
PC3	LPTIM1_ETR	SPI2_MOSI/ I2S2_SD	LPTIM2_ETR	FDCAN2_TX	-	-	-	-
PC4	USART3_TX	USART1_TX	TIM2_CH1_ETR	FDCAN1_RX	-	-	-	-
PC5	USART3_RX	USART1_RX	TIM2_CH2	FDCAN1_TX	-	-	-	-
PC6	UCPD1_FRSTX	TIM3_CH1	TIM2_CH3	LPUART2_TX	-	-	-	-
PC7	UCPD2_FRSTX	TIM3_CH2	TIM2_CH4	LPUART2_RX	-	-	-	-
PC8	UCPD2_FRSTX	TIM3_CH3	TIM1_CH1	LPUART2_CTS	-	-	-	-
PC9	I2S_CKIN	TIM3_CH4	TIM1_CH2	LPUART2_RTS_ DE	-	-	USB_NOE	-
PC10	USART3_TX	USART4_TX	TIM1_CH3	-	SPI3_SCK	-	-	-
PC11	USART3_RX	USART4_RX	TIM1_CH4	-	SPI3_MISO	-	-	-
PC12	LPTIM1_IN1	UCPD1_FRSTX	TIM14_CH1	USART5_TX	SPI3_MOSI	-	-	-
PC13	-	-	TIM1_BKIN	-	-	-	-	-
PC14	-	-	TIM1_BKIN2	-	-	-	-	-
PC15	OSC32_EN	OSC_EN	TIM15_BKIN	-	-	-	-	-



Table 18. Port D alternate function mapping

Port	AF0	AF1	AF2	AF3	AF4	AF5	AF6	AF7
PD0	EVENTOUT	SPI2_NSS/ I2S2_WS	TIM16_CH1	FDCAN1_RX	-	-	-	-
PD1	EVENTOUT	SPI2_SCK/ I2S2_CK	TIM17_CH1	FDCAN1_TX	-	-	-	-
PD2	USART3_RTS _DE_CK	TIM3_ETR	TIM1_CH1N	USART5_RX	-	-	-	-
PD3	USART2_CTS	SPI2_MISO/ I2S2_MCK	TIM1_CH2N	USART5_TX	-	-	-	-
PD4	USART2_RTS _DE_CK	SPI2_MOSI/ I2S2_SD	TIM1_CH3N	USART5_RTS _DE_CK	-	-	-	-
PD5	USART2_TX	SPI1_MISO/ I2S1_MCK	TIM1_BKIN	USART5_CTS	-	-	-	-
PD6	USART2_RX	SPI1_MOSI/ I2S1_SD	LPTIM2_OUT	-	-	-	-	-
PD7	-	-	-	MCO2	-	-	-	-
PD8	USART3_TX	SPI1_SCK/ I2S1_CK	LPTIM1_OUT	-	-	-	-	-
PD9	USART3_RX	SPI1_NSS/ I2S1_WS	TIM1_BKIN2	-	-	-	-	-
PD10	MCO	-	-	-	-	-	-	-
PD11	USART3_CTS	LPTIM2_ETR	-	-	-	-	-	-
PD12	USART3_RTS _DE_CK	LPTIM2_IN1	TIM4_CH1	FDCAN1_RX	-	-	-	-
PD13	-	LPTIM2_OUT	TIM4_CH2	FDCAN1_TX	-	-	-	-
PD14	-	LPUART2_CTS	TIM4_CH3	FDCAN2_RX	-	-	-	-
PD15	CRS1_SYNC	LPUART2_RTS _DE	TIM4_CH4	FDCAN2_TX	-	-	-	-



Table 19. Port E alternate function mapping

Port	AF0	AF1	AF2	AF3	AF4	AF5	AF6	AF7
PE0	TIM16_CH1	EVENTOUT	TIM4_ETR	-	-	-	-	-
PE1	TIM17_CH1	EVENTOUT	-	-	-	-	-	-
PE2	-	TIM3_ETR	-	-	-	-	-	-
PE3	-	TIM3_CH1	-	-	-	-	-	-
PE4	-	TIM3_CH2	-	-	-	-	-	-
PE5	-	TIM3_CH3	-	-	-	-	-	-
PE6	-	TIM3_CH4	-	-	-	-	-	-
PE7	-	TIM1_ETR	-	USART5_RTS_D E_CK	-	-	-	-
PE8	USART4_TX	TIM1_CH1N	-	-	-	-	-	-
PE9	USART4_RX	TIM1_CH1	-	-	-	-	-	-
PE10	-	TIM1_CH2N	-	USART5_TX	-	-	-	-
PE11	-	TIM1_CH2	-	USART5_RX	-	-	-	-
PE12	SPI1_NSS/ I2S1_WS	TIM1_CH3N	-	-	-	-	-	-
PE13	SPI1_SCK/ I2S1_CK	TIM1_CH3	-	-	-	-	-	-
PE14	SPI1_MISO/I2S1 _MCK	TIM1_CH4	TIM1_BK2	-	-	-	-	-
PE15	SPI1_MOSI/I2S1 _SD	TIM1_BK	-	-	-	-	-	-



Table 20. Port F alternate function mapping

Port	AF0	AF1	AF2	AF3	AF4	AF5	AF6	AF7
PF0	CRS1_SYNC	EVENTOUT	TIM14_CH1	-	-	-	-	-
PF1	OSC_EN	EVENTOUT	TIM15_CH1N	-	-	-	-	-
PF2	MCO	LPUART2_TX	-	LPUART2_RTS_DE	-	-	-	-
PF3	-	LPUART2_RX	-	USART6_RTS_DE_CK	-	-	-	-
PF4	-	LPUART1_TX	-	-	-	-	-	-
PF5	-	LPUART1_RX	-	-	-	-	-	-
PF6	-	LPUART1_RTS_DE	-	-	-	-	-	-
PF7	-	LPUART1_CTS	-	USART5_CTS	-	-	-	-
PF8	-	-	-	-	-	-	-	-
PF9	-	-	-	USART6_TX	-	-	-	-
PF10	-	-	-	USART6_RX	-	-	-	-
PF11	-	-	-	USART6_RTS_DE_CK	-	-	-	-
PF12	TIM15_CH1	-	-	USART6_CTS	-	-	-	-
PF13	TIM15_CH2	-	-	-	-	-	-	-

5 Electrical characteristics

5.1 Parameter conditions

Unless otherwise specified, all voltages are referenced to V_{SS} .

Parameter values defined at temperatures or in temperature ranges out of the ordering information scope are to be ignored.

Packages used for characterizing certain electrical parameters may differ from the commercial packages as per the ordering information.

5.1.1 Minimum and maximum values

Unless otherwise specified, the minimum and maximum values are guaranteed in the worst conditions of ambient temperature, supply voltage and frequencies by tests in production on 100% of the devices with an ambient temperature at $T_A = 25\text{ °C}$ and $T_A = T_{A(max)}$ (given by the selected temperature range).

Data based on characterization results, design simulation and/or technology characteristics are indicated in the table footnotes and are not tested in production. Based on characterization, the minimum and maximum values refer to sample tests and represent the mean value plus or minus three times the standard deviation (mean $\pm 3\sigma$).

5.1.2 Typical values

Unless otherwise specified, typical data are based on $T_A = 25\text{ °C}$, $V_{DD} = V_{DDA} = V_{DDIO2} = 3\text{ V}$. They are given only as design guidelines and are not tested.

Typical ADC accuracy values are determined by characterization of a batch of samples from a standard diffusion lot over the full temperature range, where 95% of the devices have an error less than or equal to the value indicated (mean $\pm 2\sigma$).

5.1.3 Typical curves

Unless otherwise specified, all typical curves are given only as design guidelines and are not tested.

5.1.4 Loading capacitor

The loading conditions used for pin parameter measurement are shown in [Figure 13](#).

5.1.5 Pin input voltage

The input voltage measurement on a pin of the device is described in [Figure 14](#).

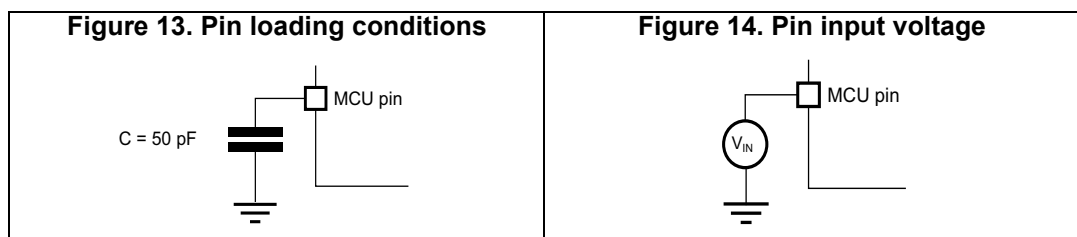

5.1.7 Current consumption measurement

Figure 16. Current consumption measurement scheme

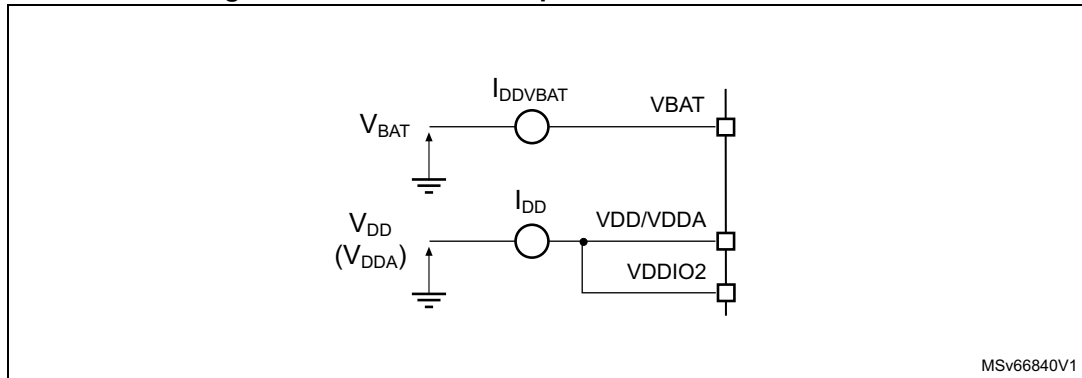

5.2 Absolute maximum ratings

Stresses above the absolute maximum ratings listed in [Table 21](#), [Table 22](#) and [Table 23](#) may cause permanent damage to the device. These are stress ratings only and functional operation of the device at these conditions is not implied. Exposure to maximum rating conditions for extended periods may affect device reliability. The device mission profile (application conditions) is compliant with the JEDEC JESD47 qualification standard.

All voltages are defined with respect to V_{SS} .

Table 21. Voltage characteristics

Symbol	Ratings	Min	Max	Unit
V_{DD}	External supply voltage	-0.3	4.0	V
V_{DDIO2}	External supply voltage for selected I/Os	-0.3	4.0	V
V_{BAT}	External supply voltage on VBAT pin	-0.3	4.0	V
V_{REF+}	External voltage on VREF+ pin	-0.3	Min($V_{DD} + 0.4$, 4.0)	V
$V_{IN}^{(1)}$	Input voltage on FT_xx pins except FT_c and FT_s	-0.3	$V_{DD} + 4.0^{(2)(3)}$	V
	Input voltage on FT_s pins except FT_cs	-0.3	$V_{DDIO2} + 4.0^{(2)}$	
	Input voltage on FT_c pins	-0.3	5.5	
	Input voltage on any other pin	-0.3	4.0	

1. Refer to [Table 22](#) for the maximum allowed injected current values.
2. To sustain a voltage higher than 4 V the internal pull-up/pull-down resistors must be disabled.
3. When an FT_a pin is used by an analog peripheral such as ADC, the maximum V_{IN} is 4 V.

Table 22. Current characteristics

Symbol	Ratings	Max	Unit
$I_{V_{DD}/V_{DDA}, V_{DDIO2}}$	Current into VDD/VDDA and VDDIO2 power pins (source) ⁽¹⁾	100	mA
$I_{V_{SS}/V_{SSA}, V_{SS}}$	Current out of VSS/VSSA and VSS ground pins (sink) ⁽²⁾	100	mA

Table 22. Current characteristics (continued)

Symbol	Ratings	Max	Unit
I _{IO(PIN)}	Output current sunk by any I/O and control pin except FT_f	15	mA
	Output current sunk by any FT_f pin	20	
	Output current sourced by any I/O and control pin	15	
ΣI _{IO(PIN)}	Total output current sunk by sum of all I/Os and control pins	80	mA
	Total output current sourced by sum of all I/Os and control pins	80	
I _{INJ(PIN)} ⁽²⁾	Injected current on a FT_xx pin	-5 / NA ⁽³⁾	mA
	Injected current on a TT_a pin ⁽⁴⁾	-5 / 0	
Σ I _{INJ(PIN)}	Total injected current (sum of all I/Os and control pins) ⁽⁵⁾	25	mA

1. All main power (VDD/VDDA, VDDIO2, VBAT) and ground (VSS/VSSA, VSS) pins must always be connected to the external power supplies, in the permitted range.
2. A positive injection is induced by V_{IN} > V_{DDIOx} while a negative injection is induced by V_{IN} < V_{SS}. I_{INJ(PIN)} must never be exceeded. Refer also to [Table 21: Voltage characteristics](#) for the maximum allowed input voltage values.
3. Positive injection is not possible on these I/Os and does not occur for input voltages lower than the specified maximum value.
4. On these I/Os, any current injection disturbs the analog performances of the device.
5. When several inputs are submitted to a current injection, the maximum Σ|I_{INJ(PIN)}| is the absolute sum of the negative injected currents (instantaneous values).

Table 23. Thermal characteristics

Symbol	Ratings	Value	Unit
T _{STG}	Storage temperature range	-65 to +150	°C
T _J	Maximum junction temperature	150	°C

5.3 Operating conditions

5.3.1 General operating conditions

Table 24. General operating conditions

Symbol	Parameter	Conditions	Min	Max	Unit
f _{HCLK}	Internal AHB clock frequency	-	0	64	MHz
f _{PCLK}	Internal APB clock frequency	-	0	64	
V _{DD}	Standard operating voltage	-	1.7 ⁽¹⁾	3.6	V
V _{DDIO2}	External supply voltage for selected I/Os	-	1.65	3.6	V
V _{DDA}	Analog supply voltage	For ADC and COMP operation	1.62	3.6	V
		For DAC operation	1.8	3.6	
		For VREFBUF operation	2.4	3.6	
V _{BAT}	Backup operating voltage	-	1.55	3.6	V



Table 24. General operating conditions (continued)

Symbol	Parameter	Conditions	Min	Max	Unit
V _{IN}	I/O input voltage	All except: RST, TT_xx, FT_c	-0.3	Min(V _{DD} + 3.6, 5.5) ⁽²⁾	V
		RST	-0.3	V _{DD} + 0.3	
		TT_xx	-0.3	V _{DDA} + 0.3	
		FT_c	-0.3	5.0 ⁽²⁾	
T _A	Ambient temperature ⁽³⁾	Suffix 6 ⁽⁴⁾	-40	85	°C
		Suffix 7 ⁽⁴⁾	-40	105	
		Suffix 3 ⁽⁴⁾	-40	125	
T _J	Junction temperature	Suffix 6 ⁽⁴⁾	-40	105	°C
		Suffix 7 ⁽⁴⁾	-40	125	
		Suffix 3 ⁽⁴⁾	-40	130	

1. When RESET is released functionality is guaranteed down to V_{PDR} min.
2. For operation with voltage higher than V_{DD} + 0.3 V, the internal pull-up and pull-down resistors must be disabled.
3. The T_A(max) applies to P_D(max). At P_D < P_D(max) the ambient temperature is allowed to go higher than T_A(max) provided that the junction temperature T_J does not exceed T_J(max). Refer to [Section 6.12: Thermal characteristics](#).
4. Temperature range digit in the order code. See [Section 7: Ordering information](#).

5.3.2 Operating conditions at power-up / power-down

The parameters given in [Table 25](#) are derived from tests performed under the ambient temperature condition summarized in [Table 24](#).

Table 25. Operating conditions at power-up / power-down

Symbol	Parameter	Conditions	Min	Max	Unit
t _{VDD}	V _{DD} slew rate	V _{DD} rising	-	∞	µs/V
		V _{DD} falling; ULPEN = 0	10	∞	
		V _{DD} falling; ULPEN = 1	100	∞	ms/V

5.3.3 Embedded reset and power control block characteristics

The parameters given in [Table 26](#) are derived from tests performed under the ambient temperature conditions summarized in [Table 24: General operating conditions](#).

Table 26. Embedded reset and power control block characteristics

Symbol	Parameter	Conditions ⁽¹⁾	Min	Typ	Max	Unit
t _{RSTTEMPO} ⁽²⁾	POR temporization when V _{DD} crosses V _{POR}	V _{DD} rising	-	250	400	µs
V _{POR} ⁽²⁾	Power-on reset threshold	-	1.62	1.66	1.70	V
V _{PDR} ⁽²⁾	Power-down reset threshold	-	1.60	1.64	1.69	V
V _{BOR1}	Brownout reset threshold 1	V _{DD} rising	2.05	2.10	2.18	V
		V _{DD} falling	1.95	2.00	2.08	

Table 26. Embedded reset and power control block characteristics (continued)

Symbol	Parameter	Conditions ⁽¹⁾	Min	Typ	Max	Unit
V _{BOR2}	Brownout reset threshold 2	V _{DD} rising	2.20	2.31	2.38	V
		V _{DD} falling	2.10	2.21	2.28	
V _{BOR3}	Brownout reset threshold 3	V _{DD} rising	2.50	2.62	2.68	V
		V _{DD} falling	2.40	2.52	2.58	
V _{BOR4}	Brownout reset threshold 4	V _{DD} rising	2.80	2.91	3.00	V
		V _{DD} falling	2.70	2.81	2.90	
V _{PVD0}	Programmable voltage detector threshold 0	V _{DD} rising	2.05	2.15	2.22	V
		V _{DD} falling	1.95	2.05	2.12	
V _{PVD1}	PVD threshold 1	V _{DD} rising	2.20	2.30	2.37	V
		V _{DD} falling	2.10	2.20	2.27	
V _{PVD2}	PVD threshold 2	V _{DD} rising	2.35	2.46	2.54	V
		V _{DD} falling	2.25	2.36	2.44	
V _{PVD3}	PVD threshold 3	V _{DD} rising	2.50	2.62	2.70	V
		V _{DD} falling	2.40	2.52	2.60	
V _{PVD4}	PVD threshold 4	V _{DD} rising	2.65	2.74	2.87	V
		V _{DD} falling	2.55	2.64	2.77	
V _{PVD5}	PVD threshold 5	V _{DD} rising	2.80	2.91	3.03	V
		V _{DD} falling	2.70	2.81	2.93	
V _{PVD6}	PVD threshold 6	V _{DD} rising	2.90	3.01	3.14	V
		V _{DD} falling	2.80	2.91	3.04	
V _{hyst_POR_PDR}	Hysteresis of V _{POR} and V _{PDR}	Hysteresis in continuous mode	-	20	-	mV
		Hysteresis in other mode	-	30	-	
V _{hyst BOR_PVD}	Hysteresis of V _{BORx} and V _{PVDx}	-	-	100	-	mV
I _{DD(BOR_PVD)} ⁽²⁾	BOR and PVD consumption	-	-	1.1	1.6	μA

1. Continuous mode means Run/Sleep modes, or temperature sensor enable in Low-power run/Low-power sleep modes.

2. Specified by design. Not tested in production.

5.3.4 Embedded voltage reference

The parameters given in [Table 27](#) are derived from tests performed under the ambient temperature and supply voltage conditions summarized in [Table 24: General operating conditions](#).

Table 27. Embedded internal voltage reference

Symbol	Parameter	Conditions	Min	Typ	Max	Unit
V_{REFINT}	Internal reference voltage	$-40^{\circ}\text{C} < T_J < 130^{\circ}\text{C}$	1.182	1.212	1.232	V
$t_{S_vrefint}^{(1)}$	ADC sampling time when reading the internal reference voltage	-	4 ⁽²⁾	-	-	μs
$t_{start_vrefint}$	Start time of reference voltage buffer when ADC is enable	-	-	8	12 ⁽²⁾	μs
$I_{DD(VREFINTBUF)}$	V_{REFINT} buffer consumption from V_{DD} when converted by ADC	-	-	12.5	20 ⁽²⁾	μA
ΔV_{REFINT}	Internal reference voltage spread over the temperature range	$V_{DD} = 3\text{ V}$	-	5	7.5 ⁽²⁾	mV
$T_{Coef_vrefint}$	Temperature coefficient	-	-	30	50 ⁽²⁾	ppm/ $^{\circ}\text{C}$
A_{Coef}	Long term stability	1000 hours, $T = 25^{\circ}\text{C}$	-	300	1000 ⁽²⁾	ppm
V_{DDCoef}	Voltage coefficient	$3.0\text{ V} < V_{DD} < 3.6\text{ V}$	-	250	1200 ⁽²⁾	ppm/V
V_{REFINT_DIV1}	1/4 reference voltage	-	24	25	26	% V_{REFINT}
V_{REFINT_DIV2}	1/2 reference voltage		49	50	51	
V_{REFINT_DIV3}	3/4 reference voltage		74	75	76	

1. The shortest sampling time can be determined in the application by multiple iterations.
2. Specified by design. Not tested in production.

Figure 17. V_{REFINT} vs. temperature

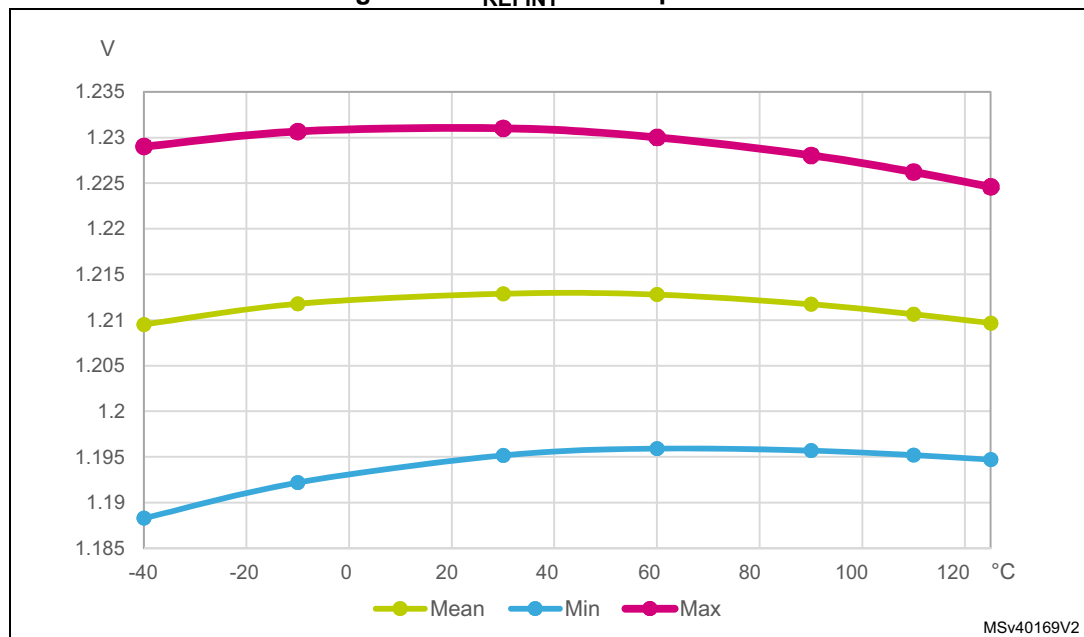

5.3.5 Supply current characteristics

The current consumption is a function of several parameters and factors such as the operating voltage, ambient temperature, I/O pin loading, device software configuration, operating frequencies, I/O pin switching rate, program location in memory and executed binary code.

The current consumption is measured as described in [Figure 16: Current consumption measurement scheme](#).

Typical and maximum current consumption

The MCU is placed under the following conditions:

- All I/O pins are in analog input mode
- All peripherals are disabled except when explicitly mentioned
- The flash memory access time is adjusted with the minimum wait states number, depending on the f_{HCLK} frequency (refer to the table “Number of wait states according to CPU clock (HCLK) frequency” available in the RM0444 reference manual).
- When the peripherals are enabled $f_{PCLK} = f_{HCLK}$
- For flash memory and shared peripherals $f_{PCLK} = f_{HCLK} = f_{HCLKS}$

Unless otherwise stated, values given in [Table 28](#) through [Table 36](#) are derived from tests performed under ambient temperature and supply voltage conditions summarized in [Table 24: General operating conditions](#).

Table 28. Current consumption in Run and Low-power run modes at different die temperatures

Symbol	Parameter	Conditions			Typ			Max ⁽¹⁾			Unit
		General	f _{HCLK}	Fetch from ⁽²⁾	25 °C	85 °C	125 °C	25 °C	85 °C	130 °C	
I _{DD(Run)}	Supply current in Run mode (from flash memory)	Range 1; PLL enabled; f _{HCLK} = f _{HSE_bypass} (≤16 MHz), f _{HCLK} = f _{PLLCLK} (>16 MHz); ⁽³⁾	64 MHz	Flash memory	8.6	8.8	9.4	9.0	9.1	9.7	mA
			56 MHz		7.5	7.8	8.3	7.9	8.0	8.6	
			48 MHz		6.7	7.0	7.6	7.1	7.2	7.8	
			32 MHz		4.6	4.8	5.4	4.8	5.0	5.5	
			24 MHz		3.6	3.8	4.3	3.8	4.1	4.6	
			16 MHz		2.3	2.5	3.0	2.4	2.6	3.2	
			64 MHz	SRAM	8.8	8.9	9.4	9.3	9.4	9.9	
			56 MHz		7.7	7.8	8.3	8.2	8.3	8.8	
			48 MHz		6.9	7.0	7.5	7.3	7.4	7.9	
			32 MHz		4.7	4.8	5.3	5.0	5.1	5.6	
			24 MHz		3.6	3.8	4.3	4.1	4.2	4.7	
			16 MHz		2.3	2.4	2.9	2.5	2.6	3.2	
		Range 2; PLL enabled; f _{HCLK} = f _{HSE_bypass} (≤16 MHz), f _{HCLK} = f _{PLLCLK} (>16 MHz); ⁽³⁾	16 MHz	Flash memory	1.8	2.0	2.4	2.2	2.3	2.9	
			8 MHz		1.0	1.1	1.6	1.3	1.4	2.1	
			2 MHz		0.3	0.4	0.9	0.6	0.9	1.4	
			16 MHz	SRAM	1.9	2.0	2.5	2.3	2.4	3.0	
			8 MHz		1.0	1.1	1.6	1.3	1.5	2.1	
			2 MHz		0.3	0.4	0.9	0.6	0.9	1.4	
I _{DD(LPRun)}	Supply current in Low-power run mode	PLL disabled; f _{HCLK} = f _{HSE_bypass} (> 32 kHz), f _{HCLK} = f _{LSE_bypass} (= 32 kHz); ⁽³⁾	2 MHz	Flash memory	280	415	950	585	845	1515	µA
			1 MHz		155	285	820	530	835	1315	
			500 kHz		90	220	750	475	795	1220	
			125 kHz		45	170	700	445	745	1190	
			32 kHz		30	155	695	430	720	1185	
			2 MHz	SRAM	250	360	855	575	835	1495	
			1 MHz		140	260	730	530	825	1300	
			500 kHz		80	205	650	475	780	1230	
			125 kHz		40	155	635	440	745	1200	
			32 kHz		30	135	625	415	715	1180	

1. Based on characterization results, not tested in production.
2. Prefetch and cache enabled when fetching from flash memory. Code compiled with high optimization for space in SRAM.
3. V_{DD} = 3.0 V for values in Typ columns and 3.6 V for values in Max columns, all peripherals disabled.



Table 29. Typical current consumption in Run and Low-power run modes, depending on code executed

Symbol	Parameter	Conditions			Typ	Unit	Typ	Unit
		General	Code	Fetch from ⁽¹⁾	25 °C		25 °C	
I _{DD(Run)}	Supply current in Run mode	Range 1; f _{HCLK} = f _{PLLCLK} = 64 MHz; (2)	Reduced code ⁽³⁾	Flash memory	8.70	mA	136	μA/MHz
			Coremark		8.15		127	
			Dhrystone 2.1		8.00		125	
			Fibonacci		7.30		114	
			While(1) loop		5.90		92	
			Reduced code ⁽³⁾	SRAM	8.85		138	
			Coremark		9.10		142	
			Dhrystone 2.1		8.95		140	
			Fibonacci		9.85		154	
			While(1) loop		8.85		138	
		Range 2; f _{HCLK} = f _{HS16} = 16 MHz, PLL disabled, (2)	Reduced code ⁽³⁾	Flash memory	2.45	153		
			Coremark		1.90	119		
			Dhrystone 2.1		1.90	119		
			Fibonacci		1.70	106		
			While(1) loop		1.35	84		
			Reduced code ⁽³⁾	SRAM	2.10	131		
			Coremark		2.10	131		
			Dhrystone 2.1		2.05	128		
			Fibonacci		2.25	141		
			While(1) loop		2.05	128		
I _{DD(LPRun)}	Supply current in Low-power run mode	f _{HCLK} = f _{HS16} /8 = 2 MHz; PLL disabled, (2)	Reduced code ⁽³⁾	Flash memory	485	μA	243	μA/MHz
			Coremark		475		238	
			Dhrystone 2.1		480		240	
			Fibonacci		500		250	
			While(1) loop		515		258	
			Reduced code ⁽³⁾	SRAM	490		245	
			Coremark		485		243	
			Dhrystone 2.1		480		240	
			Fibonacci		510		255	
			While(1) loop		480		240	

1. Prefetch and cache enabled when fetching from flash memory. Code compiled with high optimization for space in SRAM.
2. V_{DD} = 3.3 V, all peripherals disabled, cache enabled, prefetch disabled for execution in flash memory and enabled in SRAM



3. Reduced code used for characterization results provided in [Table 28](#).

Table 30. Current consumption in Sleep and Low-power sleep modes

Symbol	Parameter	Conditions			Typ			Max ⁽¹⁾			Unit
		General	Voltage scaling	f _{HCLK}	25 °C	85 °C	125 °C	25 °C	85 °C	130 °C	
I _{DD(Sleep)}	Supply current in Sleep mode	Flash memory enabled; f _{HCLK} = f _{HSE} bypass (≤16 MHz; PLL disabled), f _{HCLK} = f _{PLLCLK} (>16 MHz; PLL enabled); All peripherals disabled	Range 1	64 MHz	1.9	2.0	2.6	2.5	2.6	3.3	mA
				56 MHz	1.7	1.8	2.4	2.2	2.4	3.2	
				48 MHz	1.5	1.6	2.2	1.9	2.1	2.8	
				32 MHz	1.1	1.2	1.8	1.4	1.6	2.3	
				24 MHz	0.9	1.0	1.6	1.2	1.3	2.1	
				16 MHz	0.5	0.6	1.2	0.7	0.9	1.6	
			Range 2	16 MHz	0.4	0.6	1.0	0.6	0.7	1.4	
				8 MHz	0.3	0.4	0.9	0.4	0.5	1.2	
I _{DD(LP Sleep)}	Supply current in Low-power sleep mode	Flash memory disabled; PLL disabled; f _{HCLK} = f _{HSE} bypass (> 32 kHz), f _{HCLK} = f _{LSE} bypass (= 32 kHz); All peripherals disabled		2 MHz	70	200	705	175	500	1325	µA
				1 MHz	48	175	685	145	438	1285	
				500 kHz	37	165	670	130	413	1255	
				125 kHz	28	155	665	105	388	1250	
				32 kHz	26	150	660	90	375	1210	

1. Based on characterization results, not tested in production.

Table 31. Current consumption in Stop 0 mode

Symbol	Parameter	Conditions		Typ			Max ⁽¹⁾			Unit
		HSI kernel	V _{DD}	25 °C	85 °C	125 °C	25 °C	85 °C	130 °C	
I _{DD(Stop 0)}	Supply current in Stop 0 mode	Enabled	1.8 V	290	370	675	370	470	850	µA
			2.4 V	295	370	680	370	470	870	
			3 V	295	375	695	375	475	930	
			3.6 V	300	380	695	375	475	1050	
		Disabled	1.8 V	100	190	505	180	290	680	
			2.4 V	100	195	510	180	290	685	
			3 V	105	195	525	180	295	695	
			3.6 V	105	200	530	185	305	830	

1. Based on characterization results, not tested in production.

Table 32. Current consumption in Stop 1 mode

Symbol	Parameter	Conditions			Typ			Max ⁽¹⁾			Unit
		Flash memory	RTC ⁽²⁾	V _{DD}	25°C	85°C	125°C	25°C	85°C	130°C	
I _{DD(Stop 1)}	Supply current in Stop 1 mode	Not powered	Disabled	1.8 V	2.9	25	105	7.3	78.1	336	µA
				2.4 V	3.1	26	110	9.4	97.5	392	
				3 V	3.3	26	110	14.6	106	440	
				3.6 V	3.6	26	110	17.1	110	500	
			Enabled	1.8 V	3.3	25	105	8.3	78.1	336	
				2.4 V	3.6	26	110	10.9	97.5	392	
				3 V	3.7	26	110	16.3	106	440	
				3.6 V	4.2	27	110	19.9	115	500	
		Powered	Disabled	1.8 V	7.0	30	110	17.5	93.8	352	
				2.4 V	7.3	30	115	22.1	113	410	
				3 V	7.5	30	115	33.1	123	460	
				3.6 V	7.8	31	115	36.9	132	523	

1. Based on characterization results, not tested in production.

2. Clocked by LSI

Table 33. Current consumption in Standby mode

Symbol	Parameter	Conditions		Typ			Max ⁽¹⁾			Unit
		General	V _{DD}	25°C	85°C	125°C	25°C	85°C	130°C	
I _{DD(Standby)}	Supply current in Standby mode ⁽²⁾	RTC disabled	1.8 V	0.1	2.1	9.4	0.8	14	45	µA
			2.4 V	0.1	2.5	11.5	1.2	17	54	
			3.0 V	0.2	3.0	13.5	1.4	18	64	
			3.6 V	0.3	3.5	16.0	1.8	21	74	
		RTC enabled, clocked by LSI;	1.8 V	0.4	2.3	9.7	2.0	15	45	
			2.4 V	0.5	2.8	11.5	2.5	18	55	
			3.0 V	0.7	3.4	14.0	3.0	20	64	
			3.6 V	0.9	4.0	16.0	3.3	23	75	
		IWDG enabled, clocked by LSI	1.8 V	0.3	2.3	9.6	2.1	14	45	
			2.4 V	0.4	2.7	11.5	2.3	17	54	
			3.0 V	0.5	3.3	13.5	2.6	19	64	
			3.6 V	0.7	3.8	16.0	3.0	22	74	
		ENB_ULP = 0	1.8 V	0.7	2.0	9.4	-	-	-	
			2.4 V	0.9	2.4	11.0	-	-	-	
			3.0 V	1.1	2.9	13.5	-	-	-	
			3.6 V	1.3	3.4	15.5	-	-	-	

Table 33. Current consumption in Standby mode (continued)

Symbol	Parameter	Conditions		Typ			Max ⁽¹⁾			Unit
		General	V _{DD}	25°C	85°C	125°C	25°C	85°C	130°C	
$\Delta I_{DD(SRAM)}$	Extra supply current to retain SRAM content ⁽³⁾	SRAM retention enabled	1.8 V	1.0	11.5	57	4.3	41	265	μA
			2.4 V	1.0	11.5	57	4.3	41	265	
			3.0 V	1.1	11.6	58	4.4	41	270	
			3.6 V	1.2	11.6	59	4.4	42	270	

1. Based on characterization results, not tested in production.
2. Without SRAM retention and with ULPEN bit set
3. To be added to I_{DD(Standby)} as appropriate

Table 34. Current consumption in Shutdown mode

Symbol	Parameter	Conditions		Typ			Max ⁽¹⁾			Unit
		RTC	V _{DD}	25 °C	85 °C	125 °C	25 °C	85 °C	130 °C	
I _{DD(Shutdown)}	Supply current in Shutdown mode	Disabled	1.8 V	23	840	7050	240	3210	39200	nA
			2.4 V	38	965	8050	370	3910	44600	
			3.0 V	38	1100	9550	370	4700	51500	
			3.6 V	57	1350	11000	500	5700	59400	
		Enabled, clocked by LSE bypass at 32.768 kHz	1.8 V	235	1050	7400	290	3850	47000	
			2.4 V	320	1250	8400	440	4690	53500	
			3.0 V	425	1500	9950	450	5640	61800	
			3.6 V	550	1850	11500	590	6840	71200	

1. Based on characterization results, not tested in production.

Table 35. Current consumption in VBAT mode

Symbol	Parameter	Conditions		Typ			Unit
		RTC	V _{DD}	25°C	85°C	125°C	
I _{DD(VBAT)}	Supply current in VBAT mode	Enabled, clocked by LSE bypass at 32.768 kHz	1.8 V	195	416	2015	nA
			2.4 V	320	530	2366	
			3.0 V	492	635	2838	
			3.6 V	627	908	3339	
		Enabled, clocked by LSE crystal at 32.768 kHz	1.8 V	130	325	1550	
			2.4 V	160	400	1800	
			3.0 V	210	500	2050	
			3.6 V	285	605	2400	
		Disabled	1.8 V	4	160	1450	
			2.4 V	4	190	1700	
			3.0 V	4	220	1950	
			3.6 V	7	270	2250	

I/O system current consumption

The current consumption of the I/O system has two components: static and dynamic.

I/O static current consumption

All the I/Os used with internal or external pull-up or pull-down resistor generate current consumption when the pin is externally or internally tied low or high, respectively. The value of this current consumption can be simply computed by using the pull-up/pull-down resistor values. For internal pull-up/pull-down resistors, the indicative values are given in [Table 55: I/O static characteristics](#). Any other external load must also be considered to estimate the current consumption.

Additional I/O current consumption is due to I/Os configured as inputs if an intermediate voltage level is externally applied. This current consumption is caused by the input Schmitt trigger circuits used to discriminate the input value. Unless this specific configuration is required by the application, this supply current consumption can be avoided by configuring these I/Os in analog mode. This is notably the case of ADC input pins which should be configured as analog inputs.

Caution: Any floating input pin can also settle to an intermediate voltage level or switch inadvertently, as a result of external electromagnetic noise. To avoid current consumption related to floating pins, they must either be configured in analog mode, or forced internally to a definite digital value. This can be done either by using pull-up/down resistors or by configuring the pins in output mode.

I/O dynamic current consumption

In addition to the internal peripheral current consumption measured previously (see [Table 36: Current consumption of peripherals](#)), the I/Os used by an application also contribute to the current consumption. When an I/O pin switches, it uses the current from the I/O supply voltage to supply the I/O pin circuitry and to charge/discharge the capacitive load (internal and external) connected to the pin:

$$I_{SW} = V_{DDIOx} \times f_{SW} \times C$$

where

I_{SW} is the current sunk by a switching I/O to charge/discharge the capacitive load

V_{DDIOx} is the I/O supply voltage

f_{SW} is the I/O switching frequency

C is the total capacitance seen by the I/O pin: $C = C_{INT} + C_{EXT} + C_S$

C_S is the PCB board capacitance including the pad pin.

The test pin is configured in push-pull output mode and is toggled by software at a fixed frequency.

On-chip peripheral current consumption

The current consumption of the on-chip peripherals is given in the following table. The MCU is placed under the following conditions:

- All I/O pins are in Analog mode
- The given value is calculated by measuring the difference of the current consumptions:
 - when the peripheral is clocked on
 - when the peripheral is clocked off
- Ambient operating temperature and supply voltage conditions summarized in [Table 21: Voltage characteristics](#)
- The power consumption of the digital part of the on-chip peripherals is given in the following table. The power consumption of the analog part of the peripherals (where applicable) is indicated in each related section of the datasheet.

Table 36. Current consumption of peripherals

Peripheral	Bus	Consumption in $\mu\text{A}/\text{MHz}$		
		Range 1	Range 2	Low-power run and sleep
IOPORT Bus	IOPORT	0.5	0.4	0.3
GPIOA	IOPORT	3.1	2.4	3.0
GPIOB	IOPORT	2.9	2.3	3.0
GPIOC	IOPORT	3.0	2.4	2.8
GIOD	IOPORT	2.7	2.2	2.5
GPIOE	IOPORT	1.6	1.4	1.6
GPIOF	IOPORT	2.8	2.3	2.6
Bus matrix	AHB	0.5	0.5	0.5
All AHB Peripherals	AHB	31	26	30
DMA1/DMAMUX	AHB	5.1	4.3	4.9
CRC	AHB	0.4	0.4	0.5
FLASH	AHB	22	18	21
All APB peripherals	APB	120	110	220
AHB to APB bridge ⁽¹⁾	APB	0.2	0.2	0.1
PWR	APB	0.4	0.3	0.4
WWDG	APB	0.4	0.4	0.4
DMA2	APB	1.5	1.3	1.5
TIM1	APB	7.6	6.3	7.2
TIM2	APB	5.2	4.3	4.9
TIM3	APB	4.7	3.9	4.3
TIM4	APB	4.4	3.7	4.2
TIM6	APB	1.2	1.0	1.1
TIM7	APB	0.8	0.7	0.8
TIM14	APB	1.4	1.2	1.3

Table 36. Current consumption of peripherals (continued)

Peripheral	Bus	Consumption in $\mu\text{A}/\text{MHz}$		
		Range 1	Range 2	Low-power run and sleep
TIM15	APB	4.2	3.5	3.9
TIM16	APB	2.7	2.3	2.5
TIM17	APB	0.8	0.7	0.7
LPTIM1	APB	3.3	2.7	3.1
LPTIM2	APB	3.2	2.7	3.1
I2C1	APB	3.6	3.0	3.3
I2C2	APB	3.4	2.8	3.2
I2C3	APB	0.9	0.7	0.8
SPI1	APB	2.2	1.9	2.1
SPI2	APB	2.1	1.7	2.0
SPI3	APB	1.4	1.2	1.3
USART1	APB	7.4	6.2	6.9
USART2	APB	7.4	6.2	7.0
USART3	APB	7.4	6.2	6.9
USART4	APB	2.1	1.8	2.0
USART5	APB	2.3	1.9	2.1
USART6	APB	2.2	1.8	2.1
LPUART1	APB	4.5	3.7	4.2
LPUART2	APB	4.9	4.1	4.6
ADC	APB	2.4	2.0	2.3
DAC1	APB	1.9	1.6	1.8
SYSCFG/VREFBUF/COMP	APB	0.5	0.4	0.5
CEC	APB	0.4	0.3	0.3
CRS	APB	0.2	0.2	0.3
USB	APB	3.3	2.7	3.0
FDCAN	APB	16	13	15
UCPD1	APB	4.0	7.9	59.0 ⁽²⁾
UCPD2	APB	4.0	7.9	59.5 ⁽²⁾

1. The AHB to APB Bridge is automatically active when at least one peripheral is ON on the APB.
2. UCPDx are always clocked by HSI16.

5.3.6 Wakeup time from low-power modes and voltage scaling transition times

The wakeup times given in [Table 37](#) are the latency between the event and the execution of the first user instruction.

Table 37. Low-power mode wakeup times⁽¹⁾

Symbol	Parameter	Conditions	Typ	Max	Unit
t _{WUSLEEP}	Wakeup time from Sleep to Run mode	-	11	11	CPU cycles
t _{WULPSLEEP}	Wakeup time from Low-power sleep mode	Transiting to Low-power-run-mode execution in flash memory not powered in Low-power sleep mode; HCLK = HSI16 / 8 = 2 MHz	11	14	CPU cycles
t _{WUSTOP0}	Wakeup time from Stop 0	Transiting to Run-mode execution in flash memory not powered in Stop 0 mode; HCLK = HSI16 = 16 MHz; Regulator in Range 1 or Range 2	5.6	6	μs
		Transiting to Run-mode execution in SRAM or in flash memory powered in Stop 0 mode; HCLK = HSI16 = 16 MHz; Regulator in Range 1 or Range 2	2	2.4	
t _{WUSTOP1}	Wakeup time from Stop 1	Transiting to Run-mode execution in flash memory not powered in Stop 1 mode; HCLK = HSI16 = 16 MHz; Regulator in Range 1 or Range 2	9.0	11.2	μs
		Transiting to Run-mode execution in SRAM or in flash memory powered in Stop 1 mode; HCLK = HSI16 = 16 MHz; Regulator in Range 1 or Range 2	5	7.5	
		Transiting to Low-power-run-mode execution in flash memory not powered in Stop 1 mode; HCLK = HSI16/8 = 2 MHz; Regulator in low-power mode (LPR = 1 in PWR_CR1)	22	25.3	
		Transiting to Low-power-run-mode execution in SRAM or in flash memory powered in Stop 1 mode; HCLK = HSI16 / 8 = 2 MHz; Regulator in low-power mode (LPR = 1 in PWR_CR1)	18	23.5	
t _{WUSTBY}	Wakeup time from Standby mode	Transiting to Run mode; HCLK = HSI16 = 16 MHz; Regulator in Range 1	14.5	30	μs

Table 37. Low-power mode wakeup times⁽¹⁾ (continued)

Symbol	Parameter	Conditions	Typ	Max	Unit
t _{WUSHDN}	Wakeup time from Shutdown mode	Transiting to Run mode; HCLK = HSI16 = 16 MHz; Regulator in Range 1	258	340	μs
t _{WULPRUN}	Wakeup time from Low-power run mode ⁽²⁾	Transiting to Run mode; HSISYS = HSI16/8 = 2 MHz	5	7	μs

1. Based on characterization results, not tested in production.
2. Time until REGLPF flag is cleared in PWR_SR2.

Table 38. Regulator mode transition times⁽¹⁾

Symbol	Parameter	Conditions	Typ	Max	Unit
t _{VOST}	Transition times between regulator Range 1 and Range 2 ⁽²⁾	HSISYS = HSI16	20	40	μs

1. Based on characterization results, not tested in production.
2. Time until VOSF flag is cleared in PWR_SR2.

Table 39. Wakeup time using LPUART⁽¹⁾

Symbol	Parameter	Conditions	Typ	Max	Unit
t _{WULPUART}	Wakeup time needed to calculate the maximum LPUART baud rate allowing to wakeup up from Stop mode when LPUART clock source is HSI16	Stop mode 0	-	1.7	μs
		Stop mode 1	-	8.5	

1. Specified by design. Not tested in production.

5.3.7 External clock source characteristics

High-speed external user clock generated from an external source

In bypass mode the HSE oscillator is switched off and the input pin is a standard GPIO.

The external clock signal has to respect the I/O characteristics in [Section 5.3.14](#). See [Figure 18](#) for recommended clock input waveform.

Table 40. High-speed external user clock characteristics⁽¹⁾

Symbol	Parameter	Conditions	Min	Typ	Max	Unit
f _{HSE_ext}	User external clock source frequency	Voltage scaling Range 1	-	8	48	MHz
		Voltage scaling Range 2	-	8	26	
V _{HSEH}	OSC_IN input pin high level voltage	-	0.7 V _{DDIO1}	-	V _{DDIO1}	V
V _{HSEL}	OSC_IN input pin low level voltage	-	V _{SS}	-	0.3 V _{DDIO1}	V

Table 40. High-speed external user clock characteristics⁽¹⁾ (continued)

Symbol	Parameter	Conditions	Min	Typ	Max	Unit
$t_{w(HSEH)}$ $t_{w(HSEL)}$	OSC_IN high or low time	Voltage scaling Range 1	7	-	-	ns
		Voltage scaling Range 2	18	-	-	

1. Specified by design. Not tested in production.

Figure 18. High-speed external clock source AC timing diagram

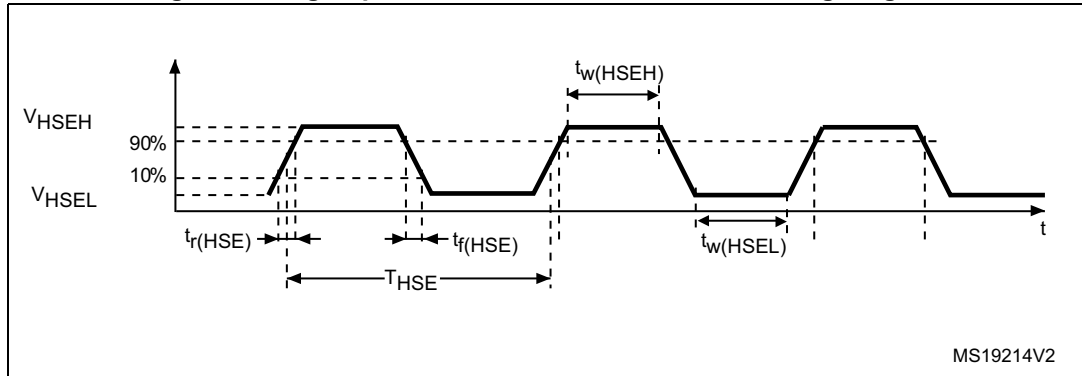

Low-speed external user clock generated from an external source

In bypass mode the LSE oscillator is switched off and the input pin is a standard GPIO.

The external clock signal has to respect the I/O characteristics in [Section 5.3.14](#). See [Figure 19](#) for recommended clock input waveform.

Table 41. Low-speed external user clock characteristics⁽¹⁾

Symbol	Parameter	Conditions	Min	Typ	Max	Unit
f_{LSE_ext}	User external clock source frequency	-	-	32.768	1000	kHz
V_{LSEH}	OSC32_IN input pin high level voltage	-	$0.7 V_{DDIO1}$	-	V_{DDIO1}	V
V_{LSEL}	OSC32_IN input pin low level voltage	-	V_{SS}	-	$0.3 V_{DDIO1}$	V
$t_{w(LSEH)}$ $t_{w(LSEL)}$	OSC32_IN high or low time	-	250	-	-	ns

1. Specified by design. Not tested in production.

Figure 19. Low-speed external clock source AC timing diagram

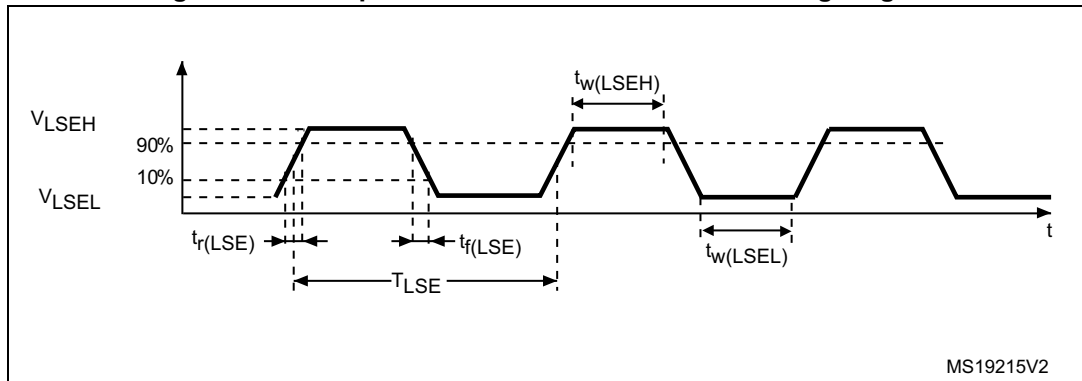

MS19215V2

High-speed external clock generated from a crystal/ceramic resonator

The high-speed external (HSE) clock can be supplied with a 4 to 48 MHz crystal/ceramic resonator oscillator. All the information given in this paragraph are based on design simulation results obtained with typical external components specified in Table 42. In the application, the resonator and the load capacitors have to be placed as close as possible to the oscillator pins in order to minimize output distortion and startup stabilization time. Refer to the crystal resonator manufacturer for more details on the resonator characteristics (frequency, package, accuracy).

Table 42. HSE oscillator characteristics⁽¹⁾

Symbol	Parameter	Conditions ⁽²⁾	Min	Typ	Max	Unit
f _{OSC_IN}	Oscillator frequency	-	4	8	48	MHz
R _F	Feedback resistor	-	-	200	-	kΩ
I _{DD(HSE)}	HSE current consumption	During startup ⁽³⁾	-	-	5.5	mA
		V _{DD} = 3 V, R _m = 30 Ω, CL = 10 pF@8 MHz	-	0.44	-	
		V _{DD} = 3 V, R _m = 45 Ω, CL = 10 pF@8 MHz	-	0.45	-	
		V _{DD} = 3 V, R _m = 30 Ω, CL = 5 pF@48 MHz	-	0.68	-	
		V _{DD} = 3 V, R _m = 30 Ω, CL = 10 pF@48 MHz	-	0.94	-	
G _m	Maximum critical crystal transconductance	Startup	-	-	1.5	mA/V
		t _{SU(HSE)} ⁽⁴⁾	Startup time	V _{DD} is stabilized	-	2

1. Specified by design. Not tested in production.

2. Resonator characteristics given by the crystal/ceramic resonator manufacturer.



3. This consumption level occurs during the first 2/3 of the $t_{SU(HSE)}$ startup time
4. $t_{SU(HSE)}$ is the startup time measured from the moment it is enabled (by software) to a stabilized 8 MHz oscillation is reached. This value is measured for a standard crystal resonator and it can vary significantly with the crystal manufacturer

For C_{L1} and C_{L2} , it is recommended to use high-quality external ceramic capacitors in the 5 pF to 20 pF range (typ.), designed for high-frequency applications, and selected to match the requirements of the crystal or resonator (see [Figure 20](#)). C_{L1} and C_{L2} are usually the same size. The crystal manufacturer typically specifies a load capacitance which is the series combination of C_{L1} and C_{L2} . PCB and MCU pin capacitance must be included (10 pF can be used as a rough estimate of the combined pin and board capacitance) when sizing C_{L1} and C_{L2} .

Note: For information on selecting the crystal, refer to the application note AN2867 “Oscillator design guide for ST microcontrollers” available from the ST website www.st.com.

Figure 20. Typical application with an 8 MHz crystal

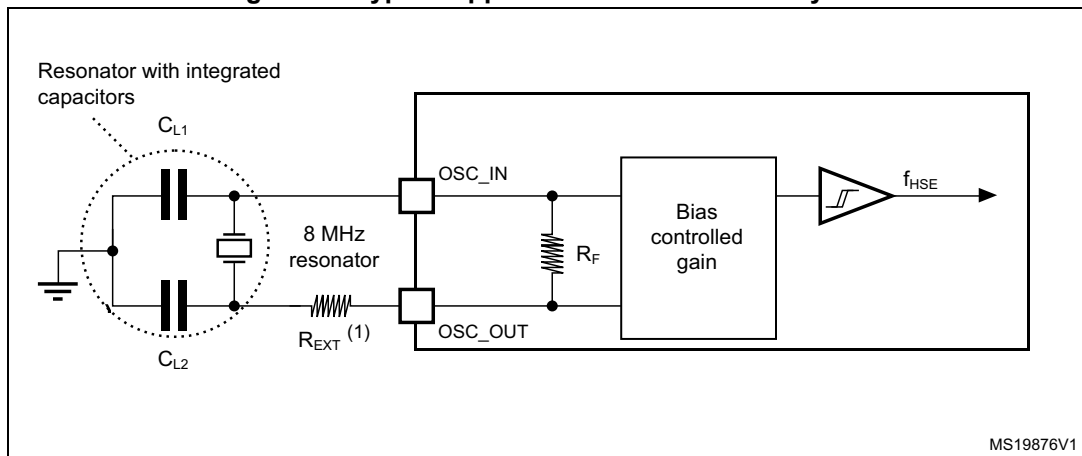

1. R_{EXT} value depends on the crystal characteristics.

Low-speed external clock generated from a crystal resonator

The low-speed external (LSE) clock can be supplied with a 32.768 kHz crystal resonator oscillator. All the information given in this paragraph are based on design simulation results obtained with typical external components specified in [Table 43](#). In the application, the resonator and the load capacitors have to be placed as close as possible to the oscillator pins in order to minimize output distortion and startup stabilization time. Refer to the crystal resonator manufacturer for more details on the resonator characteristics (frequency, package, accuracy).

Table 43. LSE oscillator characteristics ($f_{LSE} = 32.768 \text{ kHz}$)⁽¹⁾

Symbol	Parameter	Conditions ⁽²⁾	Min	Typ	Max	Unit
$I_{DD(LSE)}$	LSE current consumption	LSEDRV[1:0] = 00 Low drive capability	-	250	-	nA
		LSEDRV[1:0] = 01 Medium low drive capability	-	315	-	
		LSEDRV[1:0] = 10 Medium high drive capability	-	500	-	
		LSEDRV[1:0] = 11 High drive capability	-	630	-	
$G_{m_{critmax}}$	Maximum critical crystal gm	LSEDRV[1:0] = 00 Low drive capability	-	-	0.5	$\mu A/V$
		LSEDRV[1:0] = 01 Medium low drive capability	-	-	0.75	
		LSEDRV[1:0] = 10 Medium high drive capability	-	-	1.7	
		LSEDRV[1:0] = 11 High drive capability	-	-	2.7	
$t_{SU(LSE)}$ ⁽³⁾	Startup time	V_{DD} is stabilized	-	2	-	s

1. Specified by design. Not tested in production.
2. Refer to the note and caution paragraphs below the table, and to the application note AN2867 "Oscillator design guide for ST microcontrollers".
3. $t_{SU(LSE)}$ is the startup time measured from the moment it is enabled (by software) to a stabilized 32.768 kHz oscillation is reached. This value is measured for a standard crystal and it can vary significantly with the crystal manufacturer

Note: For information on selecting the crystal, refer to the application note AN2867 "Oscillator design guide for ST microcontrollers" available from the ST website www.st.com.

Figure 21. Typical application with a 32.768 kHz crystal

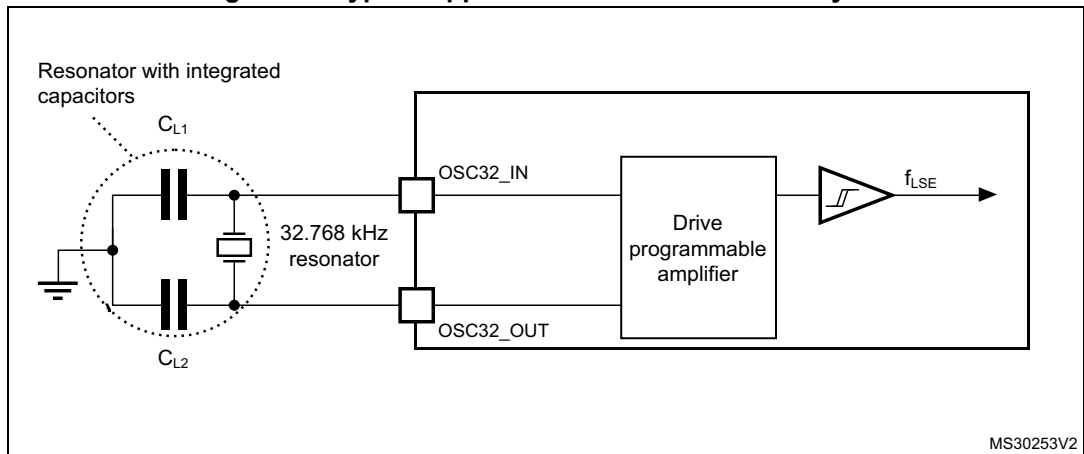

Note: An external resistor is not required between $OSC32_IN$ and $OSC32_OUT$ and it is forbidden to add one.

5.3.8 Internal clock source characteristics

The parameters given in [Table 44](#) are derived from tests performed under ambient temperature and supply voltage conditions summarized in [Table 24: General operating conditions](#). The provided curves are characterization results, not tested in production.

High-speed internal (HSI16) RC oscillator

Table 44. HSI16 oscillator characteristics⁽¹⁾

Symbol	Parameter	Conditions	Min	Typ	Max	Unit
f_{HSI16}	HSI16 Frequency	$V_{\text{DD}}=3.0\text{ V}, T_{\text{A}}=30\text{ }^{\circ}\text{C}$	15.88	-	16.08	MHz
$\Delta_{\text{Temp}}(\text{HSI16})$	HSI16 oscillator frequency drift over temperature	$T_{\text{A}}= 0\text{ to }85\text{ }^{\circ}\text{C}$	-1	-	1	%
		$T_{\text{A}}= -40\text{ to }125\text{ }^{\circ}\text{C}$	-2	-	1.5	%
$\Delta_{\text{VDD}}(\text{HSI16})$	HSI16 oscillator frequency drift over V_{DD}	$V_{\text{DD}}=1.62\text{ V to }3.6\text{ V}$	-0.1	-	0.05	%
TRIM	HSI16 frequency user trimming step	From code 127 to 128	-8	-6	-4	%
		From code 63 to 64 From code 191 to 192	-5.8	-3.8	-1.8	
		For all other code increments	0.2	0.3	0.4	
$D_{\text{HSI16}}^{(2)}$	Duty Cycle	-	45	-	55	%
$t_{\text{su}}(\text{HSI16})^{(2)}$	HSI16 oscillator start-up time	-	-	0.8	1.2	μs
$t_{\text{stab}}(\text{HSI16})^{(2)}$	HSI16 oscillator stabilization time	-	-	3	5	μs
$I_{\text{DD}}(\text{HSI16})^{(2)}$	HSI16 oscillator power consumption	-	-	155	190	μA

1. Based on characterization results, not tested in production.
2. Specified by design. Not tested in production.

Figure 22. HSI16 frequency vs. temperature

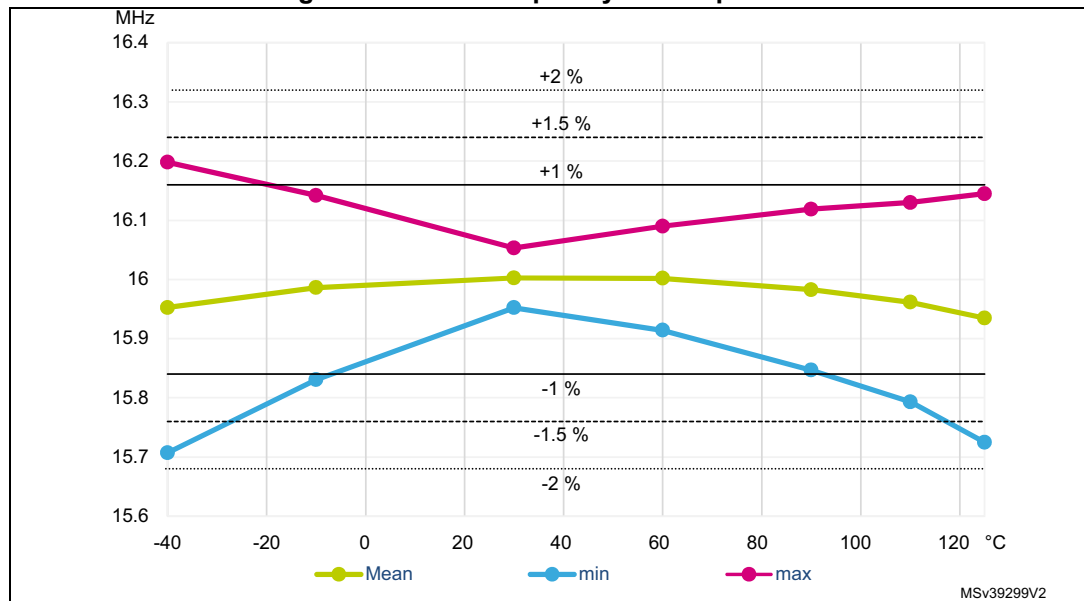

High-speed internal 48 MHz (HSI48) RC oscillator

Table 45. HSI48 oscillator characteristics⁽¹⁾

Symbol	Parameter	Conditions	Min	Typ	Max	Unit
f _{HSI48}	HSI48 Frequency	V _{DD} =3.0V, T _A =30°C	-	48	-	MHz
TRIM	HSI48 user trimming step	-	-	0.11 ⁽²⁾	0.18 ⁽²⁾	%
USER TRIM COVERAGE	HSI48 user trimming coverage	±64 steps	±6 ⁽³⁾	±7 ⁽³⁾	-	%
DuCy(HSI48)	Duty Cycle	-	45 ⁽²⁾	-	55 ⁽²⁾	%
ACC _{HSI48_REL}	Accuracy of the HSI48 oscillator over temperature (factory calibrated)	V _{DD} = 3.0 V to 3.6 V, T _A = -15 to 85 °C	-	-	±3 ⁽³⁾	%
		V _{DD} = 1.65 V to 3.6 V, T _A = -40 to 125 °C	-	-	±4.5 ⁽³⁾	
D _{VDD} (HSI48)	HSI48 oscillator frequency drift with V _{DD}	V _{DD} = 3 V to 3.6 V	-	0.025 ⁽³⁾	0.05 ⁽³⁾	%
		V _{DD} = 1.65 V to 3.6 V	-	0.05 ⁽³⁾	0.1 ⁽³⁾	
t _{su} (HSI48)	HSI48 oscillator start-up time	-	-	2.5 ⁽²⁾	6 ⁽²⁾	µs
I _{DD} (HSI48)	HSI48 oscillator power consumption	-	-	340 ⁽²⁾	380 ⁽²⁾	µA
N _T jitter	Next transition jitter Accumulated jitter on 28 cycles ⁽⁴⁾	-	-	+/-0.15 ⁽²⁾	-	ns
P _T jitter	Paired transition jitter Accumulated jitter on 56 cycles ⁽⁴⁾	-	-	+/-0.25 ⁽²⁾	-	ns

1. V_{DD} = 3 V, T_A = -40 to 125°C unless otherwise specified.
2. Specified by design. Not tested in production.
3. Evaluated by characterization. Not tested in production.
4. Jitter measurement are performed without clock source activated in parallel.

Figure 23. HSI48 frequency versus temperature

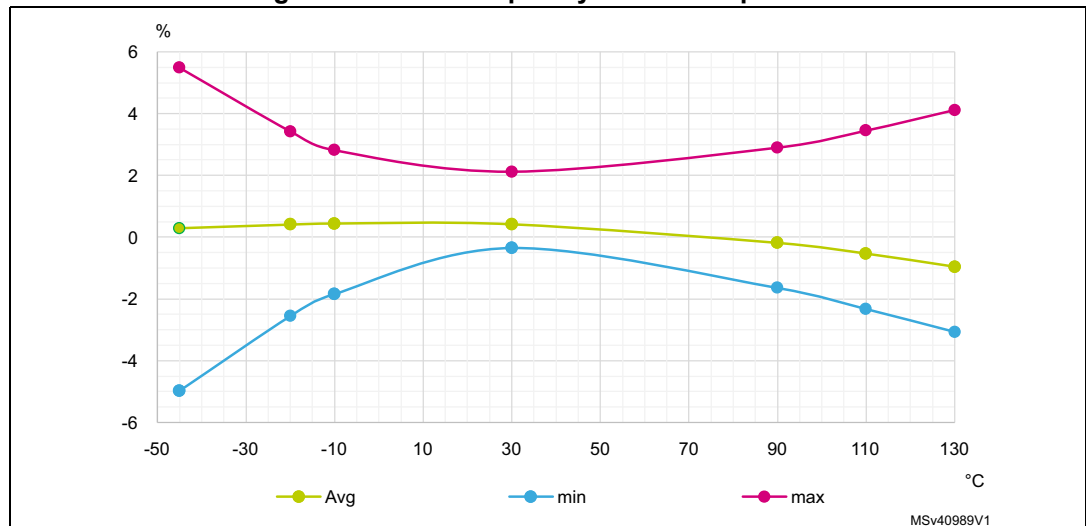

Low-speed internal (LSI) RC oscillator

Table 46. LSI oscillator characteristics⁽¹⁾

Symbol	Parameter	Conditions	Min	Typ	Max	Unit
f _{LSI}	LSI frequency	V _{DD} = 3.0 V, T _A = 30 °C	31.04	-	32.96	kHz
		V _{DD} = 1.62 V to 3.6 V, T _A = -40 to 125 °C	29.5	-	34	
t _{SU(LSI)} ⁽²⁾	LSI oscillator start-up time	-	-	80	130	µs
t _{STAB(LSI)} ⁽²⁾	LSI oscillator stabilization time	5% of final frequency	-	125	180	µs
I _{DD(LSI)} ⁽²⁾	LSI oscillator power consumption	-	-	110	180	nA

1. Based on characterization results, not tested in production.
2. Specified by design. Not tested in production.

5.3.9 PLL characteristics

The parameters given in [Table 47](#) are derived from tests performed under temperature and V_{DD} supply voltage conditions summarized in [Table 24: General operating conditions](#).

Table 47. PLL characteristics⁽¹⁾

Symbol	Parameter	Conditions	Min	Typ	Max	Unit
f _{PLL_IN}	PLL input clock frequency ⁽²⁾	-	2.66	-	16	MHz
D _{PLL_IN}	PLL input clock duty cycle	-	45	-	55	%
f _{PLL_P_OUT}	PLL multiplier output clock P	Voltage scaling Range 1	3.09	-	122	MHz
		Voltage scaling Range 2	3.09	-	40	
f _{PLL_Q_OUT}	PLL multiplier output clock Q	Voltage scaling Range 1	12	-	128	MHz
		Voltage scaling Range 2	12	-	33	
f _{PLL_R_OUT}	PLL multiplier output clock R	Voltage scaling Range 1	12	-	64	MHz
		Voltage scaling Range 2	12	-	16	
f _{VCO_OUT}	PLL VCO output	Voltage scaling Range 1	96	-	344	MHz
		Voltage scaling Range 2	96	-	128	
t _{LOCK}	PLL lock time	-	-	15	40	µs
Jitter	RMS cycle-to-cycle jitter	System clock 56 MHz	-	50	-	±ps
	RMS period jitter		-	40	-	
I _{DD(PLL)}	PLL power consumption on V _{DD} ⁽¹⁾	VCO freq = 96 MHz	-	200	260	µA
		VCO freq = 192 MHz	-	300	380	
		VCO freq = 344 MHz	-	520	650	

1. Specified by design. Not tested in production.
2. Make sure to use the appropriate division factor M to obtain the specified PLL input clock values.



5.3.10 Flash memory characteristics

Table 48. Flash memory characteristics⁽¹⁾

Symbol	Parameter	Conditions	Typ	Max	Unit
t_{prog}	64-bit programming time	-	85	125	μs
$t_{\text{prog_row}}$	Row (32 double word) programming time	Normal programming	2.7	4.6	ms
		Fast programming	1.7	2.8	
$t_{\text{prog_page}}$	Page (2 Kbyte) programming time	Normal programming	21.8	36.6	ms
		Fast programming	13.7	22.4	
t_{ERASE}	Page (2 Kbyte) erase time	-	22.0	40.0	ms
$t_{\text{prog_bank}}$	Bank (512 Kbyte ⁽²⁾) programming time	Normal programming	2.8	4.7	s
		Fast programming	1.8	2.9	
t_{ME}	Mass erase time	-	22.1	40.1	ms
$I_{\text{DD(FlashA)}}$	Average consumption from V_{DD}	Programming	3	-	mA
		Page erase	3	-	
		Mass erase	5	-	
$I_{\text{DD(FlashP)}}$	Maximum current (peak)	Programming, 2 μs peak duration	7	-	mA
		Erase, 41 μs peak duration	7	-	

1. Specified by design. Not tested in production.
2. Values provided also apply to devices with less flash memory than one 512 Kbyte bank

Table 49. Flash memory endurance and data retention

Symbol	Parameter	Conditions	Min ⁽¹⁾	Unit
N_{END}	Endurance	$T_{\text{A}} = -40$ to $+105$ °C	10	kcycles
t_{RET}	Data retention	1 kcycle ⁽²⁾ at $T_{\text{A}} = 85$ °C	30	Years
		1 kcycle ⁽²⁾ at $T_{\text{A}} = 105$ °C	15	
		1 kcycle ⁽²⁾ at $T_{\text{A}} = 125$ °C	7	
		10 kcycles ⁽²⁾ at $T_{\text{A}} = 55$ °C	30	
		10 kcycles ⁽²⁾ at $T_{\text{A}} = 85$ °C	15	
		10 kcycles ⁽²⁾ at $T_{\text{A}} = 105$ °C	10	

1. Evaluated by characterization. Not tested in production.
2. Cycling performed over the whole temperature range.

5.3.11 EMC characteristics

Susceptibility tests are performed on a sample basis during device characterization.

Functional EMS (electromagnetic susceptibility)

While a simple application is executed on the device (toggling 2 LEDs through I/O ports), the device is stressed by two electromagnetic events until a failure occurs. The failure is indicated by the LEDs:

- **Electrostatic discharge (ESD)** (positive and negative) is applied to all device pins until a functional disturbance occurs. This test is compliant with the IEC 61000-4-2 standard.
- **FTB:** A Burst of Fast Transient voltage (positive and negative) is applied to V_{DD} and V_{SS} through a 100 pF capacitor, until a functional disturbance occurs. This test is compliant with the IEC 61000-4-4 standard.

A device reset allows normal operations to be resumed.

The test results are given in [Table 50](#). They are based on the EMS levels and classes defined in application note AN1709.

Table 50. EMS characteristics

Symbol	Parameter	Conditions	Level/Class
V_{FESD}	Voltage limits to be applied on any I/O pin to induce a functional disturbance	$V_{DD} = 3.3\text{ V}$, $T_A = +25\text{ °C}$, $f_{HCLK} = 64\text{ MHz}$, LQFP100, conforming to IEC 61000-4-2	2B
V_{EFTB}	Fast transient voltage burst limits to be applied through 100 pF on V_{DD} and V_{SS} pins to induce a functional disturbance	$V_{DD} = 3.3\text{ V}$, $T_A = +25\text{ °C}$, $f_{HCLK} = 64\text{ MHz}$, LQFP100, conforming to IEC 61000-4-4	5A

Designing hardened software to avoid noise problems

EMC characterization and optimization are performed at component level with a typical application environment and simplified MCU software. It should be noted that good EMC performance is highly dependent on the user application and the software in particular.

Therefore it is recommended that the user applies EMC software optimization and prequalification tests in relation with the EMC level requested for his application.

Software recommendations

The software flowchart must include the management of runaway conditions such as:

- corrupted program counter
- unexpected reset
- critical data corruption (for example control registers)

Prequalification trials

Most of the common failures (unexpected reset and program counter corruption) can be reproduced by manually forcing a low state on the NRST pin or the Oscillator pins for 1 second.

To complete these trials, ESD stress can be applied directly on the device, over the range of specification values. When unexpected behavior is detected, the software can be hardened to prevent unrecoverable errors occurring (see application note AN1015).

Electromagnetic Interference (EMI)

The electromagnetic field emitted by the device are monitored while a simple application is executed (toggling 2 LEDs through the I/O ports). This emission test is compliant with IEC 61967-2 standard which specifies the test board and the pin loading.

Table 51. EMI characteristics

Symbol	Parameter	Conditions	Monitored frequency band	Value	Unit
S _{EMI}	Peak ⁽¹⁾	f _{HSE} = 8 MHz f _{HCLK} = 64 MHz V _{DD} = 3.6 V, T _A = 25 °C, LQFP100 package compliant with IEC 61967-2	0.1 MHz to 30 MHz	9	dBµV
			30 MHz to 130 MHz	16	
			130 MHz to 1 GHz	4	
			1 GHz to 2 GHz	8	
	Level ⁽²⁾		0.1 MHz to 2 GHz	2.5	-

1. Refer to AN1709 “EMI radiated test” section.
2. Refer to AN1709 “EMI level classification” section

5.3.12 Electrical sensitivity characteristics

Based on three different tests (ESD, LU) using specific measurement methods, the device is stressed in order to determine its performance in terms of electrical sensitivity.

Electrostatic discharge (ESD)

Electrostatic discharges (a positive then a negative pulse separated by 1 second) are applied to the pins of each sample according to each pin combination. The sample size depends on the number of supply pins in the device (3 parts × (n+1) supply pins). This test conforms to the ANSI/JEDEC standard.

Table 52. ESD absolute maximum ratings

Symbol	Ratings	Conditions	Class	Maximum value ⁽¹⁾	Unit
V _{ESD(HBM)}	Electrostatic discharge voltage (human body model)	T _A = +25 °C, conforming to ANSI/ESDA/JEDEC JS-001	2	2000	V
V _{ESD(CDM)}	Electrostatic discharge voltage (charge device model)	T _A = +25 °C, conforming to ANSI/ESDA/JEDEC JS-002	C2a	250	V

1. Based on characterization results, not tested in production.



Static latch-up

Two complementary static tests are required on six parts to assess the latch-up performance:

- A supply overvoltage is applied to each power supply pin.
- A current is injected to each input, output and configurable I/O pin.

These tests are compliant with EIA/JESD 78A IC latch-up standard.

Table 53. Electrical sensitivity

Symbol	Parameter	Conditions	Class
LU	Static latch-up class	T _A = +125 °C conforming to JESD78	II Level A

5.3.13 I/O current injection characteristics

As a general rule, current injection to the I/O pins, due to external voltage below V_{SS} or above V_{DDIOx} (for standard, 3.3 V-capable I/O pins) should be avoided during normal product operation. However, in order to give an indication of the robustness of the microcontroller in cases when abnormal injection accidentally happens, susceptibility tests are performed on a sample basis during device characterization.

Functional susceptibility to I/O current injection

While a simple application is executed on the device, the device is stressed by injecting current into the I/O pins programmed in floating input mode. While current is injected into the I/O pin, one at a time, the device is checked for functional failures.

The failure is indicated by an out-of-range parameter: ADC error above a certain limit (higher than 5 LSB TUE), induced leakage current on adjacent pins out of conventional limits (-5 µA/+0 µA range) or other functional failure (for example reset occurrence or oscillator frequency deviation).

Negative induced leakage current is caused by negative injection and positive induced leakage current is caused by positive injection.

Table 54. I/O current injection susceptibility⁽¹⁾

Symbol	Description		Functional susceptibility		Unit
			Negative injection	Positive injection	
I _{INJ}	Injected current on pin	All except PA4, PA5, PA6, PB0, PB3, and PC0	-5	N/A	mA
		PA4, PA5	-5	0	mA
		PA6, PB0, PB3, and PC0	0	N/A	mA

1. Based on characterization results, not tested in production.



5.3.14 I/O port characteristics

General input/output characteristics

Unless otherwise specified, the parameters given in [Table 55](#) are derived from tests performed under the conditions summarized in [Table 24: General operating conditions](#). All I/Os are designed as CMOS- and TTL-compliant.

Note: For information on GPIO configuration, refer to the application note AN4899 “STM32 GPIO configuration for hardware settings and low-power consumption” available from the ST website www.st.com.

Table 55. I/O static characteristics

Symbol	Parameter	Conditions		Min	Typ	Max	Unit
$V_{IL}^{(1)}$	I/O input low level voltage	All except FT_c	$1.62\text{ V} < V_{DDIOx} < 3.6\text{ V}$	-	-	$0.3 \times V_{DDIOx}^{(2)}$	V
				-	-	$0.39 \times V_{DDIOx} - 0.06^{(3)}$	
		FT_c	$1.62\text{ V} < V_{DDIOx} < 2.7\text{ V}$	-	-	$0.3 \times V_{DDIOx}$	
				-	-	$0.25 \times V_{DDIOx}$	
$V_{IH}^{(1)}$	I/O input high level voltage	All except FT_c	$1.62\text{ V} < V_{DDIOx} < 3.6\text{ V}$	$0.7 \times V_{DDIOx}^{(2)}$	-	-	V
				$0.49 \times V_{DDIOx} + 0.26^{(3)}$	-	-	
		FT_c	$1.62\text{ V} < V_{DDIOx} < 3.6\text{ V}$	$0.7 \times V_{DDIOx}$	-	5	
$V_{hys}^{(3)}$	I/O input hysteresis	TT_xx, FT_xx, RST	$1.62\text{ V} < V_{DDIOx} < 3.6\text{ V}$	-	200	-	mV
I_{lkg}	Input leakage current ⁽³⁾	FT_c	$0 < V_{IN} \leq V_{DDIOx}$	-	-	2000	nA
			$V_{DDIOx} < V_{IN} \leq 5\text{ V}$	-	-	3000 ⁽⁴⁾	
		FT_d	$0 < V_{IN} \leq V_{DDIOx}$	-	-	4500	
			$V_{DDIOx} < V_{IN} \leq 5.5\text{ V}$	-	-	9000 ⁽⁴⁾	
		FT_u	$0 < V_{IN} \leq V_{DDIOx}$	-	-	± 150	
			$V_{DDIOx} \leq V_{IN} \leq V_{DDIOx} + 1\text{ V}$	-	-	2500	
			$V_{DDIOx} + 1\text{ V} < V_{IN} \leq 5.5\text{ V}$	-	-	250	
		Other FT_xx	$0 < V_{IN} \leq V_{DDIOx}$	-	-	± 70	
			$V_{DDIOx} \leq V_{IN} \leq V_{DDIOx} + 1\text{ V}$	-	-	600 ⁽⁴⁾	
			$V_{DDIOx} + 1\text{ V} < V_{IN} \leq 5.5\text{ V}$	-	-	150 ⁽⁴⁾	
		TT_a	$0 < V_{IN} \leq V_{DDIOx}$	-	-	± 150	
			$V_{DDIOx} < V_{IN} \leq V_{DDIOx} + 0.3\text{ V}$	-	-	2000 ⁽⁴⁾	
R_{PU}	Weak pull-up equivalent resistor ⁽⁵⁾	$V_{IN} = V_{SS}$		25	40	55	kΩ

Table 55. I/O static characteristics (continued)

Symbol	Parameter	Conditions	Min	Typ	Max	Unit
R _{PD}	Weak pull-down equivalent resistor ⁽⁵⁾	V _{IN} = V _{DDIOx}	25	40	55	kΩ
C _{IO}	I/O pin capacitance	-	-	5	-	pF

1. Refer to [Figure 24: I/O input characteristics](#).
2. Tested in production.
3. Specified by design. Not tested in production.
4. This value represents the pad leakage of the I/O itself. The total product pad leakage is provided by this formula:
 $I_{Total_Ileak_max} = 10 \mu A + [number\ of\ I/Os\ where\ V_{IN}\ is\ applied\ on\ the\ pad] \times I_{IKG}(Max)$.
5. Pull-up and pull-down resistors are designed with a true resistance in series with a switchable PMOS/NMOS. This PMOS/NMOS contribution to the series resistance is minimal (~10% order).

All I/Os are CMOS- and TTL-compliant (no software configuration required). Their characteristics cover more than the strict CMOS-technology or TTL parameters, as shown in [Figure 24](#).

Figure 24. I/O input characteristics

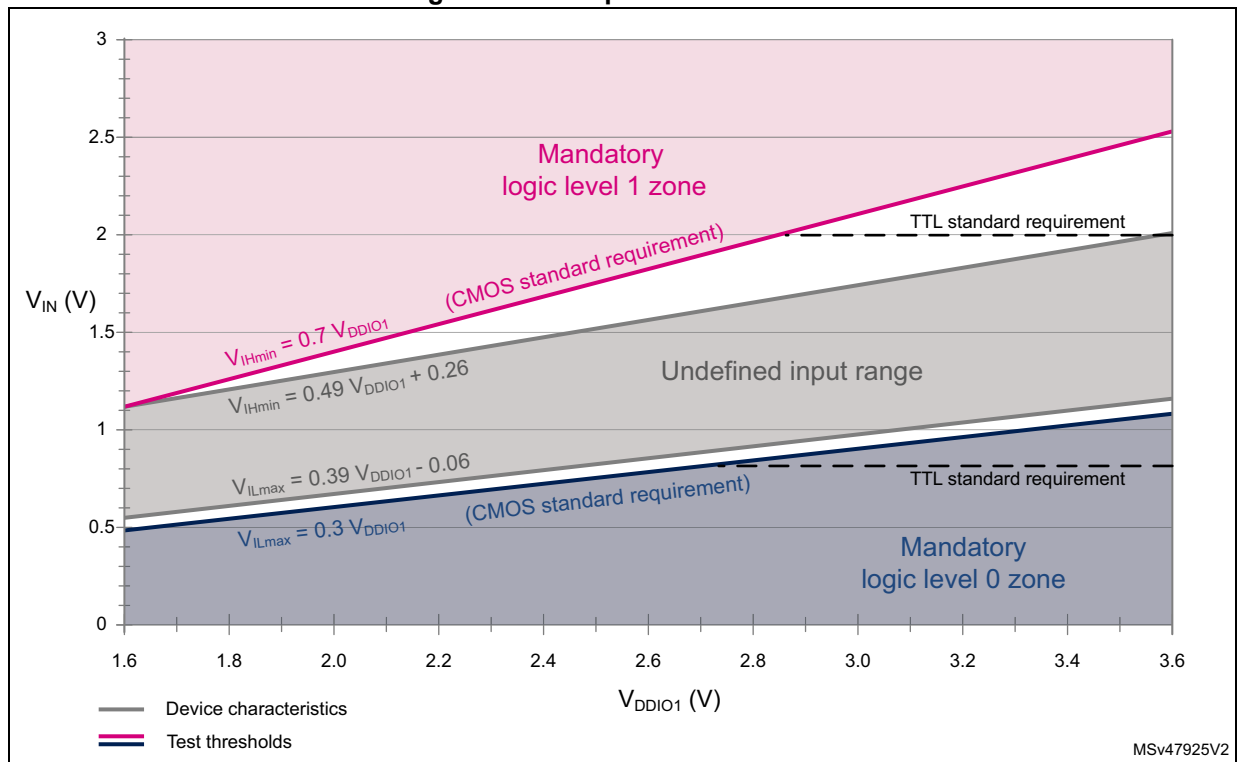

Characteristics of FT_e I/Os

The following table and figure specify input characteristics of FT_e I/Os.

Table 56. Input characteristics of FT_e I/Os

Symbol	Parameter	Conditions	Min	Typ	Max	Unit
I_{INJ}	Injected current on pin	-	-	-	5	mA
$V_{DDIO1}-V_{IN}$	Voltage over V_{DDIO1}	$I_{INJ} = 5 \text{ mA}$	-	-	2	V
R_d	Diode dynamic serial resistor	$I_{INJ} = 5 \text{ mA}$	-	-	300	Ω

Figure 25. Current injection into FT_e input with diode active

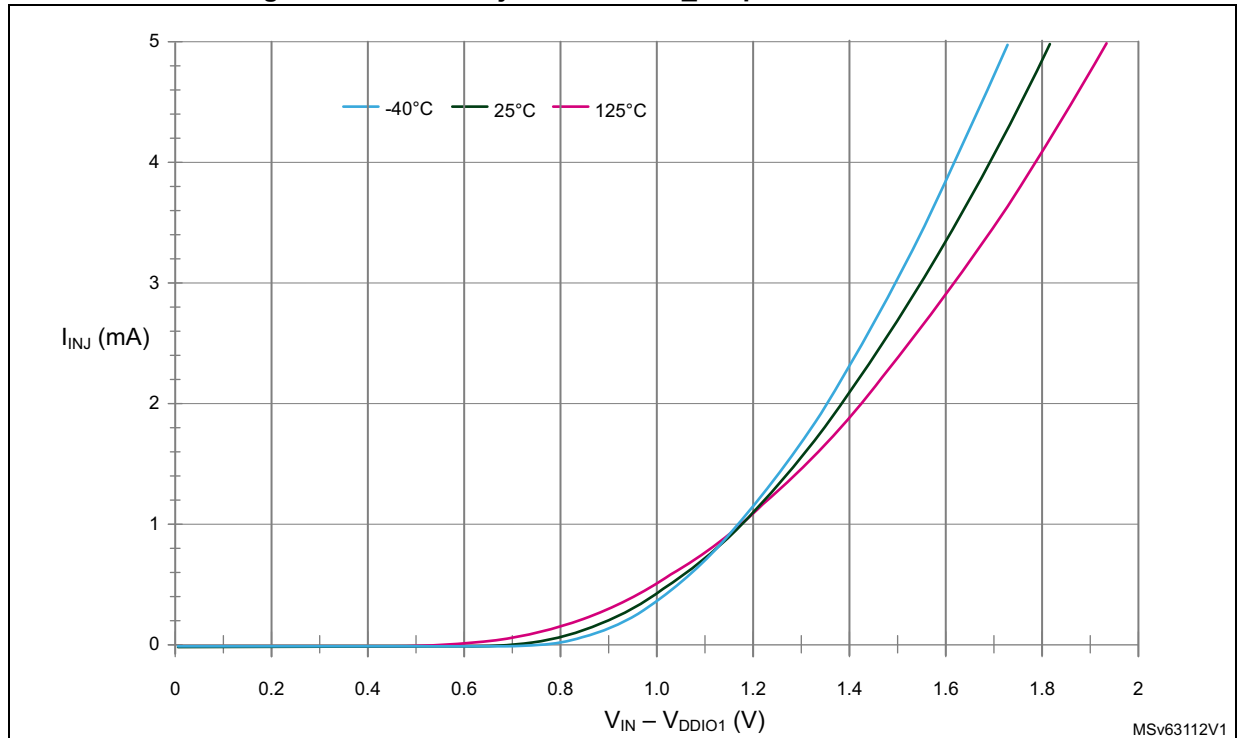

Output driving current

The GPIOs (general purpose input/outputs) can sink or source up to $\pm 8 \text{ mA}$, and up to $\pm 15 \text{ mA}$ with relaxed V_{OL}/V_{OH} .

In the user application, the number of I/O pins which can drive current must be limited to respect the absolute maximum rating specified in [Section 5.2](#):

- The sum of the currents sourced by all the I/Os on V_{DDIO1} , plus the maximum consumption of the MCU sourced on V_{DD} , cannot exceed the absolute maximum rating I_{VDD} (see [Table 21: Voltage characteristics](#)).
- The sum of the currents sunk by all the I/Os on V_{SS} , plus the maximum consumption of the MCU sunk on V_{SS} , cannot exceed the absolute maximum rating I_{VSS} (see [Table 21: Voltage characteristics](#)).

Output voltage levels

Unless otherwise specified, the parameters given in the table below are derived from tests performed under the ambient temperature and supply voltage conditions summarized in [Table 24: General operating conditions](#). All I/Os are CMOS- and TTL-compliant (FT OR TT unless otherwise specified).

Table 57. Output voltage characteristics⁽¹⁾⁽²⁾

Symbol	Parameter	Conditions	Min	Max	Unit
V_{OL}	Output low level voltage for an I/O pin	CMOS port ⁽³⁾	-	0.4	V
V_{OH}	Output high level voltage for an I/O pin	$ I_{IO} = 2 \text{ mA}$ for FT_c I/Os $= 8 \text{ mA}$ for other I/Os $V_{DDIOx} \geq 2.7 \text{ V}$	$V_{DDIOx} - 0.4$	-	V
$V_{OL}^{(4)}$	Output low level voltage for an I/O pin	TTL port ⁽³⁾	-	0.4	V
$V_{OH}^{(4)}$	Output high level voltage for an I/O pin	$ I_{IO} = 2 \text{ mA}$ for FT_c I/Os $= 8 \text{ mA}$ for other I/Os $V_{DDIOx} \geq 2.7 \text{ V}$	2.4	-	V
$V_{OL}^{(4)}$	Output low level voltage for an I/O pin	All I/Os except FT_c	-	1.3	V
$V_{OH}^{(4)}$	Output high level voltage for an I/O pin	$ I_{IO} = 15 \text{ mA}$ $V_{DDIOx} \geq 2.7 \text{ V}$	$V_{DDIOx} - 1.3$	-	V
$V_{OL}^{(4)}$	Output low level voltage for an I/O pin	$ I_{IO} = 1 \text{ mA}$ for FT_c I/Os $= 3 \text{ mA}$ for other I/Os $V_{DDIOx} \geq V_{DD}(\text{min})$	-	0.4	V
$V_{OH}^{(4)}$	Output high level voltage for an I/O pin		$V_{DDIOx} - 0.45$	-	V
$V_{OLFM+}^{(4)}$	Output low level voltage for an FT I/O pin in FM+ mode (FT I/O with _f option)	$ I_{IO} = 20 \text{ mA}$ $V_{DDIOx} \geq 2.7 \text{ V}$	-	0.4	V
		$ I_{IO} = 9 \text{ mA}$ $V_{DDIOx} \geq V_{DD}(\text{min})$	-	0.4	

- The I_{IO} current sourced or sunk by the device must always respect the absolute maximum rating specified in [Table 21: Voltage characteristics](#), and the sum of the currents sourced or sunk by all the I/Os (I/O ports and control pins) must always respect the absolute maximum ratings ΣI_{IO} .
- As PC13, PC14 and PC15 are supplied through the power switch, the sum of currents sourced by those I/Os must not exceed 3 mA.
- TTL and CMOS outputs are compatible with JEDEC standards JESD36 and JESD52.
- Specified by design. Not tested in production.

Output buffer timing characteristics

The definition and values of input/output AC characteristics are given in [Figure 26](#) and [Table 58](#), respectively.

Unless otherwise specified, the parameters given are derived from tests performed under the ambient temperature and supply voltage conditions summarized in [Table 24: General operating conditions](#).

Table 58. Non-FT_c I/O output timing characteristics⁽¹⁾⁽²⁾

Speed	Symbol	Parameter	Conditions	Min	Max	Unit
00	f _{max}	Maximum frequency	C=50 pF, 2.7 V ≤ V _{DDIOx} ≤ 3.6 V	-	2	MHz
			C=50 pF, 1.6 V ≤ V _{DDIOx} ≤ 2.7 V	-	0.35	
			C=10 pF, 2.7 V ≤ V _{DDIOx} ≤ 3.6 V	-	3	
			C=10 pF, 1.6 V ≤ V _{DDIOx} ≤ 2.7 V	-	0.45	
	t _r /t _f	Output rise and fall time	C=50 pF, 2.7 V ≤ V _{DDIOx} ≤ 3.6 V	-	100	ns
			C=50 pF, 1.6 V ≤ V _{DDIOx} ≤ 2.7 V	-	225	
			C=10 pF, 2.7 V ≤ V _{DDIOx} ≤ 3.6 V	-	75	
			C=10 pF, 1.6 V ≤ V _{DDIOx} ≤ 2.7 V	-	150	
01	f _{max}	Maximum frequency	C=50 pF, 2.7 V ≤ V _{DDIOx} ≤ 3.6 V	-	10	MHz
			C=50 pF, 1.6 V ≤ V _{DDIOx} ≤ 2.7 V	-	2	
			C=10 pF, 2.7 V ≤ V _{DDIOx} ≤ 3.6 V	-	15	
			C=10 pF, 1.6 V ≤ V _{DDIOx} ≤ 2.7 V	-	2.5	
	t _r /t _f	Output rise and fall time	C=50 pF, 2.7 V ≤ V _{DDIOx} ≤ 3.6 V	-	30	ns
			C=50 pF, 1.6 V ≤ V _{DDIOx} ≤ 2.7 V	-	60	
			C=10 pF, 2.7 V ≤ V _{DDIOx} ≤ 3.6 V	-	15	
			C=10 pF, 1.6 V ≤ V _{DDIOx} ≤ 2.7 V	-	30	
10	f _{max}	Maximum frequency	C=50 pF, 2.7 V ≤ V _{DDIOx} ≤ 3.6 V	-	30	MHz
			C=50 pF, 1.6 V ≤ V _{DDIOx} ≤ 2.7 V	-	15	
			C=10 pF, 2.7 V ≤ V _{DDIOx} ≤ 3.6 V	-	60	
			C=10 pF, 1.6 V ≤ V _{DDIOx} ≤ 2.7 V	-	30	
	t _r /t _f	Output rise and fall time	C=50 pF, 2.7 V ≤ V _{DDIOx} ≤ 3.6 V	-	11	ns
			C=50 pF, 1.6 V ≤ V _{DDIOx} ≤ 2.7 V	-	22	
			C=10 pF, 2.7 V ≤ V _{DDIOx} ≤ 3.6 V	-	4	
			C=10 pF, 1.6 V ≤ V _{DDIOx} ≤ 2.7 V	-	8	
11	f _{max}	Maximum frequency	C=30 pF, 2.7 V ≤ V _{DDIOx} ≤ 3.6 V	-	60	MHz
			C=30 pF, 1.6 V ≤ V _{DDIOx} ≤ 2.7 V	-	30	
			C=10 pF, 2.7 V ≤ V _{DDIOx} ≤ 3.6 V	-	80 ⁽³⁾	
			C=10 pF, 1.6 V ≤ V _{DDIOx} ≤ 2.7 V	-	40	
	t _r /t _f	Output rise and fall time	C=30 pF, 2.7 V ≤ V _{DDIOx} ≤ 3.6 V	-	5.5	ns
			C=30 pF, 1.6 V ≤ V _{DDIOx} ≤ 2.7 V	-	11	
			C=10 pF, 2.7 V ≤ V _{DDIOx} ≤ 3.6 V	-	2.5	
			C=10 pF, 1.6 V ≤ V _{DDIOx} ≤ 2.7 V	-	5	
Fm+	f _{max}	Maximum frequency	C=50 pF, 1.6 V ≤ V _{DDIOx} ≤ 3.6 V	-	1	MHz
	t _f	Output fall time ⁽⁴⁾		-	5	ns

1. The I/O speed is configured with the OSPEEDRy[1:0] bitfield. The FM+ mode is configured through the SYSCFG_CFGR1 register. Refer to the reference manual RM0444 for the description of the GPIO port configuration.
2. Specified by design. Not tested in production.
3. This value represents the I/O capability but the maximum system frequency is limited to 64 MHz.
4. The fall time is defined between 70% and 30% of the output waveform, according to I²C specification.

Table 59. FT_c I/O output timing characteristics⁽¹⁾⁽²⁾

Speed	Symbol	Parameter	Conditions	Min	Max	Unit
0	f _{max}	Maximum frequency	C=50 pF, 2.7 V ≤ V _{DDIOx} ≤ 3.6 V	-	2	MHz
			C=50 pF, 1.6 V ≤ V _{DDIOx} ≤ 2.7 V	-	1	
	t _r /t _f	Output rise and fall time	C=50 pF, 2.7 V ≤ V _{DDIOx} ≤ 3.6 V	-	170	ns
			C=50 pF, 1.6 V ≤ V _{DDIOx} ≤ 2.7 V	-	330	
1	f _{max}	Maximum frequency	C=50 pF, 2.7 V ≤ V _{DDIOx} ≤ 3.6 V	-	10	MHz
			C=50 pF, 1.6 V ≤ V _{DDIOx} ≤ 2.7 V	-	5	
	t _r /t _f	Output rise and fall time	C=50 pF, 2.7 V ≤ V _{DDIOx} ≤ 3.6 V	-	35	ns
			C=50 pF, 1.6 V ≤ V _{DDIOx} ≤ 2.7 V	-	65	

1. The I/O speed is configured using the OSPEEDRy[0] bit. Refer to the reference manual RM0444 for description of the GPIO port configuration.
2. Specified by design. Not tested in production.

Figure 26. I/O AC characteristics definition

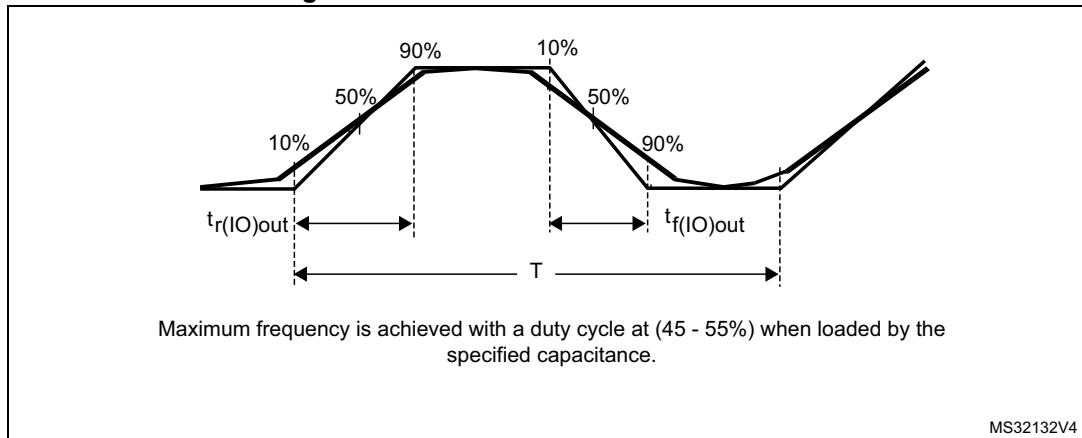

5.3.15 NRST input characteristics

The NRST input driver uses CMOS technology. It is connected to a permanent pull-up resistor, R_{PU}.

Unless otherwise specified, the parameters given in the following table are derived from tests performed under the ambient temperature and supply voltage conditions summarized in [Table 24: General operating conditions](#).

Table 60. NRST pin characteristics⁽¹⁾

Symbol	Parameter	Conditions	Min	Typ	Max	Unit
V _{IL(NRST)}	NRST input low level voltage	-	-	-	0.3 x V _{DDIO1}	V
V _{IH(NRST)}	NRST input high level voltage	-	0.7 x V _{DDIO1}	-	-	V
V _{hys(NRST)}	NRST Schmitt trigger voltage hysteresis	-	-	200	-	mV

Table 60. NRST pin characteristics⁽¹⁾ (continued)

Symbol	Parameter	Conditions	Min	Typ	Max	Unit
R _{PU}	Weak pull-up equivalent resistor ⁽²⁾	V _{IN} = V _{SS}	25	40	55	kΩ
V _{F(NRST)}	NRST input filtered pulse	-	-	-	70	ns
V _{NF(NRST)}	NRST input not filtered pulse	1.7 V ≤ V _{DD} ≤ 3.6 V	350	-	-	ns

1. Specified by design. Not tested in production.
2. The pull-up is designed with a true resistance in series with a switchable PMOS. This PMOS contribution to the series resistance is minimal (~10% order).

Figure 27. Recommended NRST pin protection

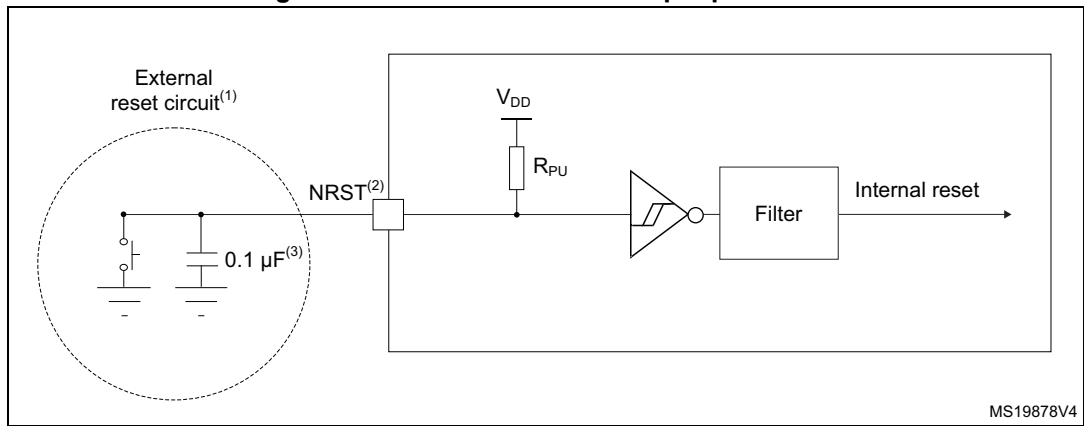

1. The reset network protects the device against parasitic resets.
2. The user must ensure that, upon power-on, the level on the NRST pin can exceed the minimum V_{IH(NRST)} level. Otherwise, the device does not exit the power-on reset. This applies to any PF2-NRST configuration set, the GPIO mode inclusive.
3. The external capacitor on NRST must be placed as close as possible to the device.

5.3.16 Extended interrupt and event controller input (EXTI) characteristics

The pulse on the interrupt input must equal or exceed the minimum length, to guarantee that it is detected by the event controller.

Table 61. EXTI input characteristics⁽¹⁾

Symbol	Parameter	Min	Typ	Max	Unit
PLEC	Pulse length to event controller	20	-	-	ns

1. Specified by design. Not tested in production.

5.3.17 Analog switch booster

Table 62. Analog switch booster characteristics⁽¹⁾

Symbol	Parameter	Min	Typ	Max	Unit
V_{DD}	Supply voltage	1.62 V	-	3.6	V
$t_{SU(BOOST)}$	Booster startup time	-	-	240	μ s
$I_{DD(BOOST)}$	Booster consumption for $1.62\text{ V} \leq V_{DD} \leq 2.0\text{ V}$	-	-	250	μ A
	Booster consumption for $2.0\text{ V} \leq V_{DD} \leq 2.7\text{ V}$	-	-	500	
	Booster consumption for $2.7\text{ V} \leq V_{DD} \leq 3.6\text{ V}$	-	-	900	

1. Specified by design. Not tested in production.

5.3.18 Analog-to-digital converter characteristics

Unless otherwise specified, the parameters given in [Table 63](#) are preliminary values derived from tests performed under ambient temperature, f_{PCLK} frequency and V_{DDA} supply voltage conditions summarized in [Table 24: General operating conditions](#).

Note: *It is recommended to perform a calibration after each power-up.*

Table 63. ADC characteristics⁽¹⁾

Symbol	Parameter	Conditions ⁽²⁾	Min	Typ	Max	Unit
V_{DDA}	Analog supply voltage	-	1.62	-	3.6	V
V_{REF+}	Positive reference voltage	$V_{DDA} \geq 2\text{ V}$	2	-	V_{DDA}	V
		$V_{DDA} < 2\text{ V}$	V_{DDA}			
f_{ADC}	ADC clock frequency	Range 1	0.14	-	35	MHz
		Range 2	0.14	-	16	
$D_{ADC}^{(3)}$	ADC analog clock duty cycle	-	45	-	55	%
f_s	Sampling rate	12 bits	-	-	2.50	MSps
		10 bits	-	-	2.92	
		8 bits	-	-	3.50	
		6 bits	-	-	4.38	
f_{TRIG}	External trigger frequency	$f_{ADC} = 35\text{ MHz}; 12\text{ bits}$	-	-	2.33	MHz
		12 bits	-	-	$f_{ADC}/15$	
$V_{AIN}^{(4)}$	Conversion voltage range	-	V_{SSA}	-	V_{REF+}	V
R_{AIN}	External input impedance	-	-	-	50	k Ω
C_{ADC}	Internal sample and hold capacitor	-	-	5	-	pF

Table 63. ADC characteristics⁽¹⁾ (continued)

Symbol	Parameter	Conditions ⁽²⁾	Min	Typ	Max	Unit
t _{STAB}	ADC power-up time	-	2			Conversion cycle
t _{CAL}	Calibration time	f _{ADC} = 35 MHz	2.35			µs
		-	82			1/f _{ADC}
W _{LATENCY}	ADC_DR register write latency	CKMODE[1:0] = 00	1.5 f _{ADC} + 2 f _{PCLK} cycles	-	1.5 f _{ADC} + 3 f _{PCLK} cycles	-
		CKMODE[1:0] = 01	-	4.5	-	1/f _{PCLK}
		CKMODE[1:0] = 10	-	8.5	-	
		CKMODE[1:0] = 11	-	2.5	-	
t _{LATR}	Trigger conversion latency	CKMODE[1:0] = 00	2	-	3	1/f _{ADC}
		CKMODE[1:0] = 01	6.5			1/f _{PCLK}
		CKMODE[1:0] = 10	12.5			
		CKMODE[1:0] = 11	3.5			
t _s	Sampling time	f _{ADC} = 35 MHz; V _{DDA} > 2V	0.043	-	4.59	µs
			1.5	-	160.5	1/f _{ADC}
		f _{ADC} = 35 MHz; V _{DDA} < 2V	0.1	-	4.59	µs
			3.5	-	160.5	1/f _{ADC}
t _{ADCVREG_STUP}	ADC voltage regulator start-up time	-	-	-	20	µs
t _{CONV}	Total conversion time (including sampling time)	f _{ADC} = 35 MHz Resolution = 12 bits	0.40	-	4.95	µs
		Resolution = 12 bits	t _s + 12.5 cycles for successive approximation = 14 to 173			1/f _{ADC}
t _{IDLE}	Laps of time allowed between two conversions without rearm	-	-	-	100	µs
I _{DDA(ADC)}	ADC consumption from V _{DDA}	f _s = 2.5 MSps	-	410	-	µA
		f _s = 1 MSps	-	164	-	
		f _s = 10 kSps	-	17	-	
I _{DDV(ADC)}	ADC consumption from V _{REF+}	f _s = 2.5 MSps	-	65	-	µA
		f _s = 1 MSps	-	26	-	
		f _s = 10 kSps	-	0.26	-	

1. Specified by design. Not tested in production.
2. I/O analog switch voltage booster must be enabled (BOOSTEN = 1 in the SYSCFG_CFGR1) when V_{DDA} < 2.4 V and disabled when V_{DDA} ≥ 2.4 V.
3. This requirement is granted when the incoming clock (PCLK or ADC asynchronous clock) is divided by two or more in the ADC. For other cases, refer to the reference manual section *ADC clock* for information on how to fulfill this requirement.



4. V_{REF+} is internally connected to V_{DDA} on some packages. Refer to [Section 4: Pinouts, pin description and alternate functions](#) for further details.

Table 64. Maximum ADC R_{AIN}

Resolution	Sampling cycle at 35 MHz	Sampling time at 35 MHz [ns]	Max. $R_{AIN}^{(1)(2)}$ (Ω)
12 bits	1.5 ⁽³⁾	43	50
	3.5	100	680
	7.5	214	2200
	12.5	357	4700
	19.5	557	8200
	39.5	1129	15000
	79.5	2271	33000
	160.5	4586	50000
10 bits	1.5 ⁽³⁾	43	68
	3.5	100	820
	7.5	214	3300
	12.5	357	5600
	19.5	557	10000
	39.5	1129	22000
	79.5	2271	39000
	160.5	4586	50000
8 bits	1.5 ⁽³⁾	43	82
	3.5	100	1500
	7.5	214	3900
	12.5	357	6800
	19.5	557	12000
	39.5	1129	27000
	79.5	2271	50000
	160.5	4586	50000

Table 64. Maximum ADC R_{AIN} (continued)

Resolution	Sampling cycle at 35 MHz	Sampling time at 35 MHz [ns]	Max. R _{AIN} ⁽¹⁾⁽²⁾ (Ω)
6 bits	1.5 ⁽³⁾	43	390
	3.5	100	2200
	7.5	214	5600
	12.5	357	10000
	19.5	557	15000
	39.5	1129	33000
	79.5	2271	50000
	160.5	4586	50000

1. Specified by design. Not tested in production.
2. I/O analog switch voltage booster must be enabled (BOOSTEN = 1 in the SYSCFG_CFGR1) when V_{DDA} < 2.4 V and disabled when V_{DDA} ≥ 2.4 V.
3. Only allowed with V_{DDA} > 2 V

Table 65. ADC accuracy⁽¹⁾⁽²⁾⁽³⁾

Symbol	Parameter	Conditions ⁽⁴⁾	Min	Typ	Max	Unit
ET	Total unadjusted error	V _{DDA} = V _{REF+} = 3 V; f _{ADC} = 35 MHz; f _s ≤ 2.5 MSps; T _A = 25 °C	-	±3	±4	LSB
		2 V < V _{DDA} =V _{REF+} < 3.6 V; f _{ADC} = 35 MHz; f _s ≤ 2.5 MSps; T _A = entire range	-	±3	±6.5	
		1.65 V < V _{DDA} =V _{REF+} < 3.6 V; T _A = entire range Range 1: f _{ADC} = 35 MHz; f _s ≤ 2.2 MSps; Range 2: f _{ADC} = 16 MHz; f _s ≤ 1.1 MSps;	-	±3	±7.5	
EO	Offset error	V _{DDA} = V _{REF+} = 3 V; f _{ADC} = 35 MHz; f _s ≤ 2.5 MSps; T _A = 25 °C	-	±1.5	±2	LSB
		2 V < V _{DDA} = V _{REF+} < 3.6 V; f _{ADC} = 35 MHz; f _s ≤ 2.5 MSps; T _A = entire range	-	±1.5	±4.5	
		1.65 V < V _{DDA} =V _{REF+} < 3.6 V; T _A = entire range Range 1: f _{ADC} = 35 MHz; f _s ≤ 2.2 MSps; Range 2: f _{ADC} = 16 MHz; f _s ≤ 1.1 MSps;	-	±1.5	±5.5	

Table 65. ADC accuracy⁽¹⁾⁽²⁾⁽³⁾ (continued)

Symbol	Parameter	Conditions ⁽⁴⁾	Min	Typ	Max	Unit
EG	Gain error	$V_{DDA} = V_{REF+} = 3\text{ V};$ $f_{ADC} = 35\text{ MHz}; f_s \leq 2.5\text{ MSps};$ $T_A = 25\text{ }^\circ\text{C}$	-	± 3	± 3.5	LSB
		$2\text{ V} < V_{DDA} = V_{REF+} < 3.6\text{ V};$ $f_{ADC} = 35\text{ MHz}; f_s \leq 2.5\text{ MSps};$ $T_A = \text{entire range}$	-	± 3	± 5	
		$1.65\text{ V} < V_{DDA} = V_{REF+} < 3.6\text{ V};$ $T_A = \text{entire range}$ Range 1: $f_{ADC} = 35\text{ MHz}; f_s \leq 2.2\text{ MSps};$ Range 2: $f_{ADC} = 16\text{ MHz}; f_s \leq 1.1\text{ MSps};$	-	± 3	± 6.5	
ED	Differential linearity error	$V_{DDA} = V_{REF+} = 3\text{ V};$ $f_{ADC} = 35\text{ MHz}; f_s \leq 2.5\text{ MSps};$ $T_A = 25\text{ }^\circ\text{C}$	-	± 1.2	± 1.5	LSB
		$2\text{ V} < V_{DDA} = V_{REF+} < 3.6\text{ V};$ $f_{ADC} = 35\text{ MHz}; f_s \leq 2.5\text{ MSps};$ $T_A = \text{entire range}$	-	± 1.2	± 1.5	
		$1.65\text{ V} < V_{DDA} = V_{REF+} < 3.6\text{ V};$ $T_A = \text{entire range}$ Range 1: $f_{ADC} = 35\text{ MHz}; f_s \leq 2.2\text{ MSps};$ Range 2: $f_{ADC} = 16\text{ MHz}; f_s \leq 1.1\text{ MSps};$	-	± 1.2	± 1.5	
EL	Integral linearity error	$V_{DDA} = V_{REF+} = 3\text{ V};$ $f_{ADC} = 35\text{ MHz}; f_s \leq 2.5\text{ MSps};$ $T_A = 25\text{ }^\circ\text{C}$	-	± 2.5	± 3	LSB
		$2\text{ V} < V_{DDA} = V_{REF+} < 3.6\text{ V};$ $f_{ADC} = 35\text{ MHz}; f_s \leq 2.5\text{ MSps};$ $T_A = \text{entire range}$	-	± 2.5	± 3	
		$1.65\text{ V} < V_{DDA} = V_{REF+} < 3.6\text{ V};$ $T_A = \text{entire range}$ Range 1: $f_{ADC} = 35\text{ MHz}; f_s \leq 2.2\text{ MSps};$ Range 2: $f_{ADC} = 16\text{ MHz}; f_s \leq 1.1\text{ MSps};$	-	± 2.5	± 3.5	
ENOB	Effective number of bits	$V_{DDA} = V_{REF+} = 3\text{ V};$ $f_{ADC} = 35\text{ MHz}; f_s \leq 2.5\text{ MSps};$ $T_A = 25\text{ }^\circ\text{C}$	10.1	10.2	-	bit
		$2\text{ V} < V_{DDA} = V_{REF+} < 3.6\text{ V};$ $f_{ADC} = 35\text{ MHz}; f_s \leq 2.5\text{ MSps};$ $T_A = \text{entire range}$	9.6	10.2	-	
		$1.65\text{ V} < V_{DDA} = V_{REF+} < 3.6\text{ V};$ $T_A = \text{entire range}$ Range 1: $f_{ADC} = 35\text{ MHz}; f_s \leq 2.2\text{ MSps};$ Range 2: $f_{ADC} = 16\text{ MHz}; f_s \leq 1.1\text{ MSps};$	9.5	10.2	-	

Table 65. ADC accuracy⁽¹⁾⁽²⁾⁽³⁾ (continued)

Symbol	Parameter	Conditions ⁽⁴⁾	Min	Typ	Max	Unit
SINAD	Signal-to-noise and distortion ratio	$V_{DDA} = V_{REF+} = 3\text{ V};$ $f_{ADC} = 35\text{ MHz}; f_s \leq 2.5\text{ MSps};$ $T_A = 25\text{ }^\circ\text{C}$	62.5	63	-	dB
		$2\text{ V} < V_{DDA} = V_{REF+} < 3.6\text{ V};$ $f_{ADC} = 35\text{ MHz}; f_s \leq 2.5\text{ MSps};$ $T_A = \text{entire range}$	59.5	63	-	
		$1.65\text{ V} < V_{DDA} = V_{REF+} < 3.6\text{ V};$ $T_A = \text{entire range}$ Range 1: $f_{ADC} = 35\text{ MHz}; f_s \leq 2.2\text{ MSps};$ Range 2: $f_{ADC} = 16\text{ MHz}; f_s \leq 1.1\text{ MSps};$	59	63	-	
SNR	Signal-to-noise ratio	$V_{DDA} = V_{REF+} = 3\text{ V};$ $f_{ADC} = 35\text{ MHz}; f_s \leq 2.5\text{ MSps};$ $T_A = 25\text{ }^\circ\text{C}$	63	64	-	dB
		$2\text{ V} < V_{DDA} = V_{REF+} < 3.6\text{ V};$ $f_{ADC} = 35\text{ MHz}; f_s \leq 2.5\text{ MSps};$ $T_A = \text{entire range}$	60	64	-	
		$1.65\text{ V} < V_{DDA} = V_{REF+} < 3.6\text{ V};$ $T_A = \text{entire range}$ Range 1: $f_{ADC} = 35\text{ MHz}; f_s \leq 2.2\text{ MSps};$ Range 2: $f_{ADC} = 16\text{ MHz}; f_s \leq 1.1\text{ MSps};$	60	64	-	
THD	Total harmonic distortion	$V_{DDA} = V_{REF+} = 3\text{ V};$ $f_{ADC} = 35\text{ MHz}; f_s \leq 2.5\text{ MSps};$ $T_A = 25\text{ }^\circ\text{C}$	-	-74	-73	dB
		$2\text{ V} < V_{DDA} = V_{REF+} < 3.6\text{ V};$ $f_{ADC} = 35\text{ MHz}; f_s \leq 2.5\text{ MSps};$ $T_A = \text{entire range}$	-	-74	-70	
		$1.65\text{ V} < V_{DDA} = V_{REF+} < 3.6\text{ V};$ $T_A = \text{entire range}$ Range 1: $f_{ADC} = 35\text{ MHz}; f_s \leq 2.2\text{ MSps};$ Range 2: $f_{ADC} = 16\text{ MHz}; f_s \leq 1.1\text{ MSps};$	-	-74	-70	

1. Based on characterization results, not tested in production.
2. ADC DC accuracy values are measured after internal calibration.
3. Injecting negative current on any analog input pin significantly reduces the accuracy of A-to-D conversion of signal on another analog input. It is recommended to add a Schottky diode (pin to ground) to analog pins susceptible to receive negative current.
4. I/O analog switch voltage booster enabled (BOOSTEN = 1 in the SYSCFG_CFGR1) when $V_{DDA} < 2.4\text{ V}$ and disabled when $V_{DDA} \geq 2.4\text{ V}$.

Figure 28. ADC accuracy characteristics

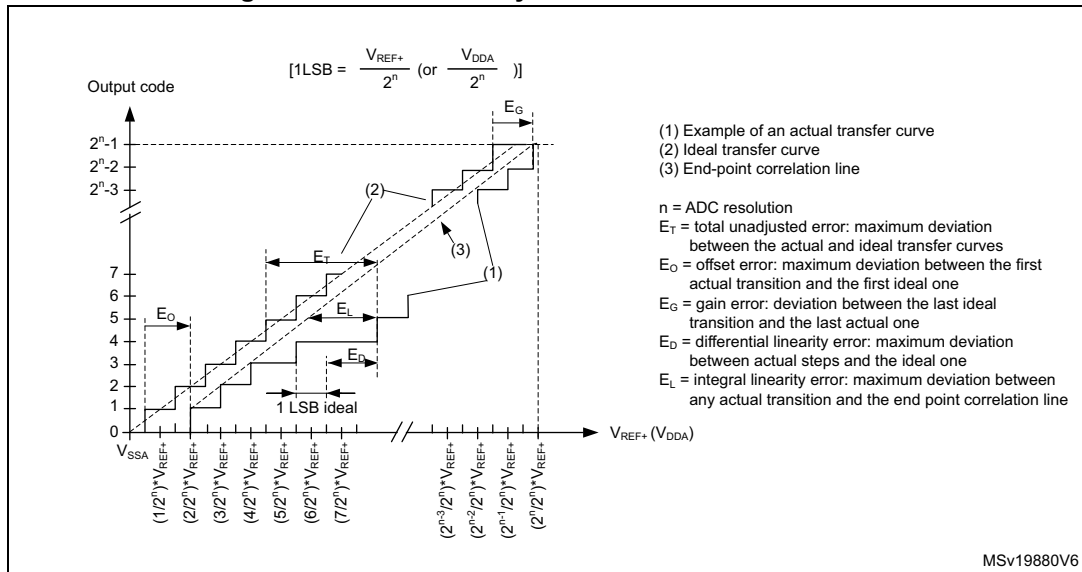
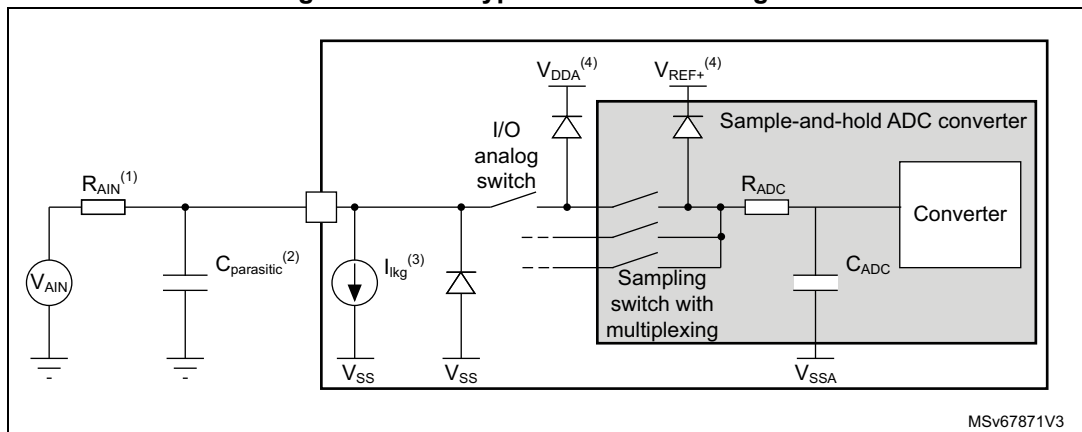

Figure 29. ADC typical connection diagram



1. Refer to [Table 63: ADC characteristics](#) for the values of R_{AIN} and C_{ADC} .
2. $C_{parasitic}$ represents the capacitance of the PCB (dependent on soldering and PCB layout quality) plus the pad capacitance (refer to [Table 55: I/O static characteristics](#) for the value of the pad capacitance). A high $C_{parasitic}$ value downgrades conversion accuracy. To remedy this, f_{ADC} should be reduced.
3. Refer to [Table 55: I/O static characteristics](#) for the values of I_{Ikg} .
4. Refer to [Figure 15: Power supply scheme](#).

General PCB design guidelines

Power supply decoupling should be performed as shown in [Figure 15: Power supply scheme](#). The 100 nF capacitor should be ceramic (good quality) and it should be placed as close as possible to the chip.

5.3.19 Digital-to-analog converter characteristics

Table 66. DAC characteristics⁽¹⁾

Symbol	Parameter	Conditions	Min	Typ	Max	Unit	
V _{DDA}	Analog supply voltage for DAC ON	DAC output buffer OFF, DAC_OUT pin not connected (internal connection only)	1.71	-	3.6	V	
		Other modes	1.80	-			
V _{REF+}	Positive reference voltage	DAC output buffer OFF, DAC_OUT pin not connected (internal connection only)	1.71	-	V _{DDA}	V	
		Other modes	1.80	-			
R _L	Resistive load	DAC output buffer ON	connected to V _{SSA}	5	-	-	kΩ
			connected to V _{DDA}	25	-	-	
R _O	Output Impedance	DAC output buffer OFF	9.6	11.7	13.8	kΩ	
R _{BON}	Output impedance sample and hold mode, output buffer ON	V _{DD} = 2.7 V	-	-	2	kΩ	
		V _{DD} = 2.0 V	-	-	3.5		
R _{BOFF}	Output impedance sample and hold mode, output buffer OFF	V _{DD} = 2.7 V	-	-	16.5	kΩ	
		V _{DD} = 2.0 V	-	-	18.0		
C _L	Capacitive load	DAC output buffer ON	-	-	50	pF	
C _{SH}		Sample and hold mode	-	0.1	1	μF	
V _{DAC_OUT}	Voltage on DAC_OUT output	DAC output buffer ON	0.2	-	V _{REF+} - 0.2	V	
		DAC output buffer OFF	0	-	V _{REF+}		
t _{SETTLING}	Settling time (full scale: for a 12-bit code transition between the lowest and the highest input codes when DAC_OUT reaches final value ±0.5LSB, ±1 LSB, ±2 LSB, ±4 LSB, ±8 LSB)	Normal mode DAC output buffer ON CL ≤ 50 pF, RL ≥ 5 kΩ	±0.5 LSB	-	1.7	3	μs
			±1 LSB	-	1.6	2.9	
			±2 LSB	-	1.55	2.85	
			±4 LSB	-	1.48	2.8	
			±8 LSB	-	1.4	2.75	
		Normal mode DAC output buffer OFF, ±1LSB, CL = 10 pF	-	2	2.5		
t _{WAKEUP} ⁽²⁾	Wakeup time from off state (setting the ENx bit in the DAC Control register) until final value ±1 LSB	Normal mode DAC output buffer ON CL ≤ 50 pF, RL ≥ 5 kΩ	-	4.2	7.5	μs	
		Normal mode DAC output buffer OFF, CL ≤ 10 pF	-	2	5		
PSRR	V _{DDA} supply rejection ratio	Normal mode DAC output buffer ON CL ≤ 50 pF, RL = 5 kΩ, DC	-	-80	-28	dB	

Table 66. DAC characteristics⁽¹⁾ (continued)

Symbol	Parameter	Conditions	Min	Typ	Max	Unit	
$T_{W_to_W}$	Minimum time between two consecutive writes into the DAC_DORx register to guarantee a correct DAC_OUT for a small variation of the input code (1 LSB)	DAC_MCR:MODEx[2:0] = 000 or 001 CL ≤ 50 pF; RL ≥ 5 kΩ	1	-	-	μs	
		DAC_MCR:MODEx[2:0] = 010 or 011 CL ≤ 10 pF	1.4	-	-		
t_{SAMP}	Sampling time in sample and hold mode (code transition between the lowest input code and the highest input code when DACOUT reaches final value ±1LSB)	DAC_OUT pin connected				ms	
		DAC output buffer ON, C _{SH} = 100 nF	-	0.7	3.5		
		DAC output buffer OFF, C _{SH} = 100 nF	-	10.5	18		
		DAC_OUT pin not connected (internal connection only)	-	2	3.5	μs	
I_{leak}	Output leakage current	Sample and hold mode, DAC_OUT pin connected	-	-	-(3)	nA	
C_{iint}	Internal sample and hold capacitor	-	5.2	7	8.8	pF	
t_{TRIM}	Middle code offset trim time	DAC output buffer ON	50	-	-	μs	
V_{offset}	Middle code offset for 1 trim code step	V _{REF+} = 3.6 V	-	1500	-	μV	
		V _{REF+} = 1.8 V	-	750	-		
$I_{DDA(DAC)}$	DAC consumption from V _{DDA}	DAC output buffer ON	No load, middle code (0x800)	-	315	500	μA
			No load, worst code (0xF1C)	-	450	670	
		DAC output buffer OFF	No load, middle code (0x800)	-	-	0.2	
		Sample and hold mode, C _{SH} = 100 nF	-	$315 \times \frac{T_{on}}{T_{on} + T_{off}}^{(4)}$	$670 \times \frac{T_{on}}{T_{on} + T_{off}}^{(4)}$		

Table 66. DAC characteristics⁽¹⁾ (continued)

Symbol	Parameter	Conditions	Min	Typ	Max	Unit	
I _{DDV(DAC)}	DAC consumption from V _{REF+}	DAC output buffer ON	No load, middle code (0x800)	-	185	240	μA
			No load, worst code (0xF1C)	-	340	400	
		DAC output buffer OFF	No load, middle code (0x800)	-	155	205	
		Sample and hold mode, buffer ON, C _{SH} = 100 nF, worst case	-	185 × $\frac{T_{on}}{T_{off}^{(4)}}$	400 × $\frac{T_{on}}{T_{off}^{(4)}}$		
		Sample and hold mode, buffer OFF, C _{SH} = 100 nF, worst case	-	155 × $\frac{T_{on}}{T_{off}^{(4)}}$	205 × $\frac{T_{on}}{T_{off}^{(4)}}$		

1. Specified by design. Not tested in production.
2. In buffered mode, the output can overshoot above the final value for low input code (starting from min value).
3. Refer to [Table 55: I/O static characteristics](#).
4. T_{on} is the Refresh phase duration. T_{off} is the Hold phase duration. Refer to RM0444 reference manual for more details.

Figure 30. 12-bit buffered / non-buffered DAC

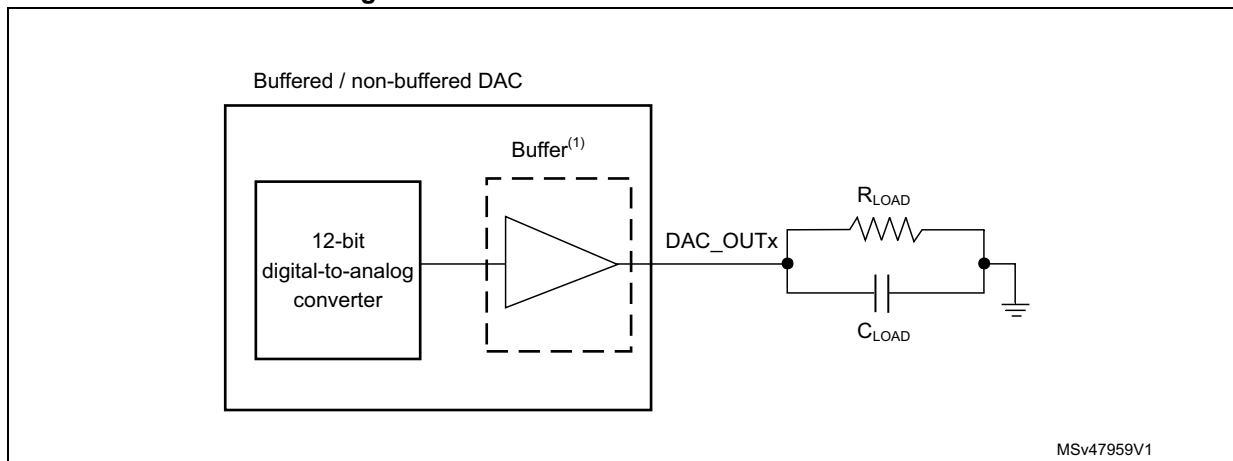

1. The DAC integrates an output buffer that can be used to reduce the output impedance and to drive external loads directly without the use of an external operational amplifier. The buffer can be bypassed by configuring the BOFFx bit in the DAC_CR register.

Table 67. DAC accuracy⁽¹⁾

Symbol	Parameter	Conditions	Min	Typ	Max	Unit
DNL	Differential non linearity ⁽²⁾	DAC output buffer ON	-	-	±2	LSB
		DAC output buffer OFF	-	-	±2	
-	monotonicity	10 bits	guaranteed			LSB

Table 67. DAC accuracy⁽¹⁾ (continued)

Symbol	Parameter	Conditions	Min	Typ	Max	Unit	
INL	Integral non linearity ⁽³⁾	DAC output buffer ON CL ≤ 50 pF, RL ≥ 5 kΩ	-	-	±4	LSB	
		DAC output buffer OFF CL ≤ 50 pF, no RL	-	-	±4		
Offset	Offset error at code 0x800 ⁽³⁾	DAC output buffer ON CL ≤ 50 pF, RL ≥ 5 kΩ	V _{REF+} = 3.6 V	-	-	±12	LSB
			V _{REF+} = 1.8 V	-	-	±25	
		DAC output buffer OFF CL ≤ 50 pF, no RL	-	-	±8		
Offset1	Offset error at code 0x001 ⁽⁴⁾	DAC output buffer OFF CL ≤ 50 pF, no RL	-	-	±5	LSB	
OffsetCal	Offset Error at code 0x800 after calibration	DAC output buffer ON CL ≤ 50 pF, RL ≥ 5 kΩ	V _{REF+} = 3.6 V	-	-	±5	LSB
			V _{REF+} = 1.8 V	-	-	±7	
Gain	Gain error ⁽⁵⁾	DAC output buffer ON CL ≤ 50 pF, RL ≥ 5 kΩ	-	-	±0.5	%	
		DAC output buffer OFF CL ≤ 50 pF, no RL	-	-	±0.5		
TUE	Total unadjusted error	DAC output buffer ON CL ≤ 50 pF, RL ≥ 5 kΩ	-	-	±30	LSB	
		DAC output buffer OFF CL ≤ 50 pF, no RL	-	-	±12		
TUECal	Total unadjusted error after calibration	DAC output buffer ON CL ≤ 50 pF, RL ≥ 5 kΩ	-	-	±23	LSB	
SNR	Signal-to-noise ratio	DAC output buffer ON CL ≤ 50 pF, RL ≥ 5 kΩ 1 kHz, BW 500 kHz	-	71.2	-	dB	
		DAC output buffer OFF CL ≤ 50 pF, no RL, 1 kHz BW 500 kHz	-	71.6	-		
THD	Total harmonic distortion	DAC output buffer ON CL ≤ 50 pF, RL ≥ 5 kΩ, 1 kHz	-	-78	-	dB	
		DAC output buffer OFF CL ≤ 50 pF, no RL, 1 kHz	-	-79	-		
SINAD	Signal-to-noise and distortion ratio	DAC output buffer ON CL ≤ 50 pF, RL ≥ 5 kΩ, 1 kHz	-	70.4	-	dB	
		DAC output buffer OFF CL ≤ 50 pF, no RL, 1 kHz	-	71	-		

Table 67. DAC accuracy⁽¹⁾ (continued)

Symbol	Parameter	Conditions	Min	Typ	Max	Unit
ENOB	Effective number of bits	DAC output buffer ON CL ≤ 50 pF, RL ≥ 5 kΩ, 1 kHz	-	11.4	-	bits
		DAC output buffer OFF CL ≤ 50 pF, no RL, 1 kHz	-	11.5	-	

1. Specified by design. Not tested in production.
2. Difference between two consecutive codes - 1 LSB.
3. Difference between measured value at Code i and the value at Code i on a line drawn between Code 0 and last Code 4095.
4. Difference between the value measured at Code (0x001) and the ideal value.
5. Difference between ideal slope of the transfer function and measured slope computed from code 0x000 and 0xFF when buffer is OFF, and from code giving 0.2 V and (V_{REF+} - 0.2) V when buffer is ON.

5.3.20 Voltage reference buffer characteristics

Table 68. VREFBUF characteristics⁽¹⁾

Symbol	Parameter	Conditions	Min	Typ	Max	Unit	
V _{DDA}	VREFBUF operating voltage	VRS = 0	2.4	-	3.6	V	
		VRS = 1	2.8	-	3.6		
V _{REFBUF_OUT}	Voltage reference output	I _{load} = 100 μA T = 30 °C	VRS = 0	2.038 ⁽²⁾	2.042	2.046	V
			VRS = 1	2.497 ⁽²⁾	2.5	2.503	
TRIM	Trim step resolution	-	-	±0.05	±0.1	%	
CL	Load capacitor	-	0.5	1	1.5	μF	
esr	Equivalent Serial Resistor of C _{load}	-	-	-	2	Ω	
I _{load}	Static load current	-	-	-	4	mA	
I _{line_reg}	Line regulation	2.8 V ≤ V _{DDA} ≤ 3.6 V	I _{load} = 500 μA	-	200	1000	ppm/V
			I _{load} = 4 mA	-	100	500	
I _{load_reg}	Load regulation	500 μA ≤ I _{load} ≤ 4 mA	Normal mode	-	50	500	ppm/mA
T _{Coeff_vrefbuf}	Temperature coefficient of VREFBUF ⁽³⁾	-40 °C < T _J < +125 °C		-	-	50	ppm/ °C
PSRR	Power supply rejection	DC	40	60	-	dB	
		100 kHz	25	40	-		
t _{START}	Start-up time	CL = 0.5 μF ⁽⁴⁾	-	300	350	μs	
		CL = 1.1 μF ⁽⁴⁾	-	500	650		
		CL = 1.5 μF ⁽⁴⁾	-	650	800		

Table 68. VREFBUF characteristics⁽¹⁾ (continued)

Symbol	Parameter	Conditions	Min	Typ	Max	Unit
I_{INRUSH}	Control of maximum DC current drive on VREFBUF_OUT during start-up phase ⁽⁵⁾	-	-	8	-	mA
$I_{DDA(VREFBUF)}$	VREFBUF consumption from V_{DDA}	$I_{load} = 0 \mu A$	-	16	25	μA
		$I_{load} = 500 \mu A$	-	18	30	
		$I_{load} = 4 mA$	-	35	50	

1. Specified by design. Not tested in production.
2. If the V_{DDA} is below the VREFBUF operating voltage, the voltage reference buffer can not maintain accurately the output voltage and it could drop down to $V_{DDA} - 150mV$.
3. The temperature coefficient at VREF+ output is the sum of $T_{Coeff_vrefint}$ and $T_{Coeff_vrefbuf}$.
4. The capacitive load must include a 100 nF capacitor in order to cut-off the high frequency noise.
5. To correctly control the VREFBUF inrush current during start-up phase and scaling change, the V_{DDA} voltage should be in the range [2.4 V to 3.6 V] and [2.8 V to 3.6 V] respectively for VRS = 0 and VRS = 1.

5.3.21 Comparator characteristics

Table 69. COMP characteristics⁽¹⁾

Symbol	Parameter	Conditions	Min	Typ	Max	Unit	
V_{DDA}	Analog supply voltage	-	1.62	-	3.6	V	
V_{IN}	Comparator input voltage range	-	0	-	V_{DDA}	V	
$V_{BG}^{(2)}$	Scaler input voltage	-	V_{REFINT}			V	
V_{SC}	Scaler offset voltage	-	-	± 5	± 10	mV	
$I_{DDA(SCALER)}$	Scaler static consumption from V_{DDA}	BRG_EN=0 (bridge disable)	-	200	300	nA	
		BRG_EN=1 (bridge enable)	-	0.8	1	μA	
t_{START_SCALER}	Scaler startup time	-	-	100	200	μs	
t_{START}	Comparator startup time to reach propagation delay specification	High-speed mode	-	-	5	μs	
		Medium-speed mode	-	-	15		
t_D	Propagation delay	200 mV step; 100 mV overdrive	High-speed mode	-	30	50	ns
			Medium-speed mode	-	0.3	0.6	μs
		>200 mV step; 100 mV overdrive	High-speed mode	-	-	70	ns
			Medium-speed mode	-	-	1.2	μs
V_{offset}	Comparator offset error	Full common mode range	-	± 5	± 20	mV	

Table 69. COMP characteristics⁽¹⁾ (continued)

Symbol	Parameter	Conditions		Min	Typ	Max	Unit
V_{hys}	Comparator hysteresis	No hysteresis		-	0	-	mV
		Low hysteresis		-	10	-	
		Medium hysteresis		-	20	-	
		High hysteresis		-	30	-	
$I_{DDA(Comp)}$	Comparator consumption from V_{DDA}	Medium-speed mode	Static	-	5	7.5	μA
			With 50 kHz and ± 100 mV overdrive square signal	-	6	-	
		High-speed mode	Static	-	250	400	
			With 50 kHz and ± 100 mV overdrive square signal	-	250	-	

1. Specified by design. Not tested in production.
2. Refer to [Table 27: Embedded internal voltage reference](#).

5.3.22 Temperature sensor characteristics

Table 70. TS characteristics

Symbol	Parameter	Min	Typ	Max	Unit
$T_L^{(1)}$	V_{TS} linearity with temperature	-	± 1	± 2	$^{\circ}C$
Avg_Slope ⁽²⁾	Average slope	2.3	2.5	2.7	mV/ $^{\circ}C$
V_{30}	Voltage at 30 $^{\circ}C$ (± 5 $^{\circ}C$) ⁽³⁾	0.742	0.76	0.785	V
$t_{START(TS_BUF)}^{(1)}$	Sensor Buffer Start-up time in continuous mode ⁽⁴⁾	-	8	15	μs
$t_{START}^{(1)}$	Start-up time when entering in continuous mode ⁽⁴⁾	-	70	120	μs
$t_{S_temp}^{(1)}$	ADC sampling time when reading the temperature	5	-	-	μs
$I_{DD(TS)}^{(1)}$	Temperature sensor consumption from V_{DD} , when selected by ADC	-	4.7	7	μA

1. Specified by design. Not tested in production.
2. Based on characterization results, not tested in production.
3. Measured at $V_{DDA} = 3.0 V \pm 10 mV$. The V_{30} ADC conversion result is stored in the TS_CAL1 byte.
4. Continuous mode means Run/Sleep modes, or temperature sensor enable in Low-power run/Low-power sleep modes.

5.3.23 V_{BAT} monitoring characteristics

Table 71. V_{BAT} monitoring characteristics

Symbol	Parameter	Min	Typ	Max	Unit
R	Resistor bridge for V_{BAT}	-	39	-	k Ω
Q	Ratio on V_{BAT} measurement	-	3	-	-

Table 71. V_{BAT} monitoring characteristics (continued)

Symbol	Parameter	Min	Typ	Max	Unit
Er ⁽¹⁾	Error on Q	-10	-	10	%
t _{S_vbat} ⁽¹⁾	ADC sampling time when reading the VBAT	12	-	-	µs

1. Specified by design. Not tested in production.

Table 72. V_{BAT} charging characteristics

Symbol	Parameter	Conditions	Min	Typ	Max	Unit
R _{BC}	Battery charging resistor	VBRS = 0	-	5	-	kΩ
		VBRS = 1	-	1.5	-	

5.3.24 Timer characteristics

The parameters given in the following tables are specified by design and not tested in production. Refer to [Section 5.3.14: I/O port characteristics](#) for details on the input/output alternate function characteristics (output compare, input capture, external clock, PWM output).

Table 73. TIMx⁽¹⁾ characteristics

Symbol	Parameter	Conditions	Min	Max	Unit
t _{res(TIM)}	Timer resolution time	-	1	-	t _{TIMxCLK}
		f _{TIMxCLK} = 64 MHz	15.625	-	ns
f _{EXT}	Timer external clock frequency on CH1 to CH4	-	0	f _{TIMxCLK} /2	MHz
		f _{TIMxCLK} = 64 MHz	0	40	
Res _{TIM}	Timer resolution	TIMx (except TIM2)	-	16	bit
		TIM2	-	32	
t _{COUNTER}	16-bit counter clock period	-	1	65536	t _{TIMxCLK}
		f _{TIMxCLK} = 64 MHz	0.015625	1024	µs
t _{MAX_COUNT}	Maximum possible count with 32-bit counter	-	-	65536 × 65536	t _{TIMxCLK}
		f _{TIMxCLK} = 64 MHz	-	67.10	s

1. TIMx is used as a general term to refer to a timer (for example, TIM1).

Table 74. IWDG min/max timeout period at 32 kHz LSI clock⁽¹⁾

Prescaler divider	PR[2:0] bits	Min timeout RL[11:0]= 0x000	Max timeout RL[11:0]= 0xFFFF	Unit
/4	0	0.125	512	ms
/8	1	0.250	1024	
/16	2	0.500	2048	
/32	3	1.0	4096	
/64	4	2.0	8192	
/128	5	4.0	16384	
/256	6 or 7	8.0	32768	

1. The exact timings further depend on the phase of the APB interface clock versus the LSI clock, which causes an uncertainty of one RC period.

5.3.25 Characteristics of communication interfaces

I²C-bus interface characteristics

The I²C-bus interface meets timing requirements of the I²C-bus specification and user manual rev. 03 for:

- Standard-mode (Sm): with a bit rate up to 100 kbit/s
- Fast-mode (Fm): with a bit rate up to 400 kbit/s
- Fast-mode Plus (Fm+): with a bit rate up to 1 Mbit/s.

The timings are ensured by design as long as the I2C peripheral is properly configured (refer to the reference manual RM0444) and when the I2CCLK frequency is greater than the minimum shown in the following table.

Table 75. Minimum I2CCLK frequency

Symbol	Parameter	Condition	Typ	Unit	
f _{I2CCLK(min)}	Minimum I2CCLK frequency for correct operation of I2C peripheral	Standard-mode		2	MHz
		Fast-mode	Analog filter enabled	9	
			DNF = 0		
			Analog filter disabled	9	
			DNF = 1		
		Fast-mode Plus	Analog filter enabled	18	
			DNF = 0		
			Analog filter disabled	16	
DNF = 1					

The SDA and SCL I/O requirements are met with the following restrictions: the SDA and SCL I/O pins are not “true” open-drain. When configured as open-drain, the PMOS connected between the I/O pin and V_{DDIO1} is disabled, but is still present. Only FT_f I/O pins

support Fm+ low-level output current maximum requirement. Refer to [Section 5.3.14: I/O port characteristics](#) for the I2C I/Os characteristics.

All I2C SDA and SCL I/Os embed an analog filter. Refer to the following table for its characteristics:

Table 76. I2C analog filter characteristics⁽¹⁾

Symbol	Parameter	Min	Max	Unit
t_{AF}	Limiting duration of spikes suppressed by the filter ⁽²⁾	50	260	ns

1. Based on characterization results, not tested in production.
2. Spikes shorter than the limiting duration are suppressed.

SPI/I²S characteristics

Unless otherwise specified, the parameters given in [Table 77](#) for SPI are derived from tests performed under the ambient temperature, f_{PCLKx} frequency and supply voltage conditions summarized in [Table 24: General operating conditions](#). The additional general conditions are:

- OSPEEDRy[1:0] set to 11 (output speed)
- capacitive load C = 30 pF
- measurement points at CMOS levels: $0.5 \times V_{DD}$

Refer to [Section 5.3.14: I/O port characteristics](#) for more details on the input/output alternate function characteristics (NSS, SCK, MOSI, MISO for SPI).

Table 77. SPI characteristics⁽¹⁾

Symbol	Parameter	Conditions	Min	Typ	Max	Unit
f_{SCK} $1/t_{c(SCK)}$	SPI clock frequency	Master mode $1.65 < V_{DD} < 3.6 \text{ V}$ Range 1	-	-	32	MHz
		Master transmitter $1.65 < V_{DD} < 3.6 \text{ V}$ Range 1			32	
		Slave receiver $1.65 < V_{DD} < 3.6 \text{ V}$ Range 1			32	
		Slave transmitter/full duplex $2.7 < V_{DD} < 3.6 \text{ V}$ Range 1			32	
		Slave transmitter/full duplex $1.65 < V_{DD} < 3.6 \text{ V}$ Range 1			23	
		$1.65 < V_{DD} < 3.6 \text{ V}$ Range 2			8	
$t_{su(NSS)}$	NSS setup time	Slave mode, SPI prescaler = 2	$4 \times T_{PCLK}$	-	-	ns
$t_h(NSS)$	NSS hold time	Slave mode, SPI prescaler = 2	$2 \times T_{PCLK}$	-	-	ns

Table 77. SPI characteristics⁽¹⁾ (continued)

Symbol	Parameter	Conditions	Min	Typ	Max	Unit
$t_{w(SCKH)}$	SCK high time	Master mode	$T_{PCLK} - 1.5$	T_{PCLK}	$T_{PCLK} + 1.5$	ns
$t_{w(SCKL)}$	SCK low time	Master mode	$T_{PCLK} - 1.5$	T_{PCLK}	$T_{PCLK} + 1.5$	ns
$t_{su(MI)}$	Master data input setup time	-	1	-	-	ns
$t_{su(SI)}$	Slave data input setup time	-	1	-	-	ns
$t_{h(MI)}$	Master data input hold time	-	5	-	-	ns
$t_{h(SI)}$	Slave data input hold time	-	1	-	-	ns
$t_{a(SO)}$	Data output access time	Slave mode	9	-	34	ns
$t_{dis(SO)}$	Data output disable time	Slave mode	9	-	16	ns
$t_{v(SO)}$	Slave data output valid time	2.7 < V_{DD} < 3.6 V Range 1	-	9	14	ns
		1.65 < V_{DD} < 3.6 V Range 1	-	9	21	
		1.65 < V_{DD} < 3.6 V Voltage Range 2	-	11	24	
$t_{v(MO)}$	Master data output valid time	-	-	3	5	ns
$t_{h(SO)}$	Slave data output hold time	-	5	-	-	ns
$t_{h(MO)}$	Master data output hold time	-	1	-	-	ns

1. Based on characterization results, not tested in production.

Figure 31. SPI timing diagram - slave mode and CPHA = 0

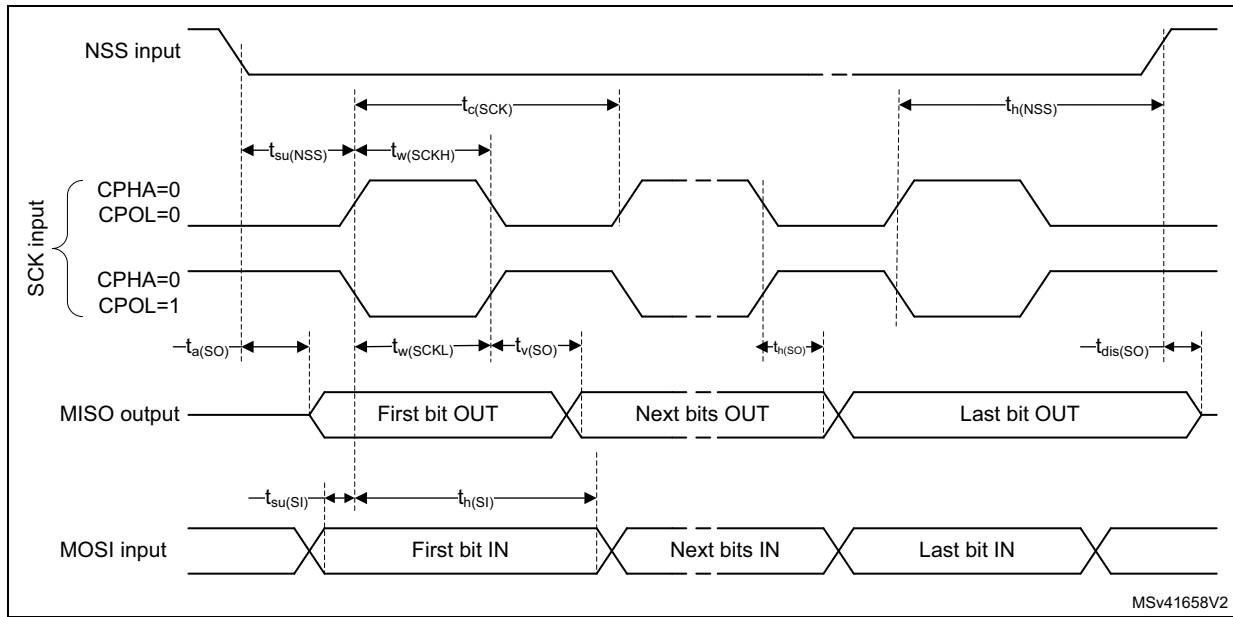

Figure 32. SPI timing diagram - slave mode and CPHA = 1

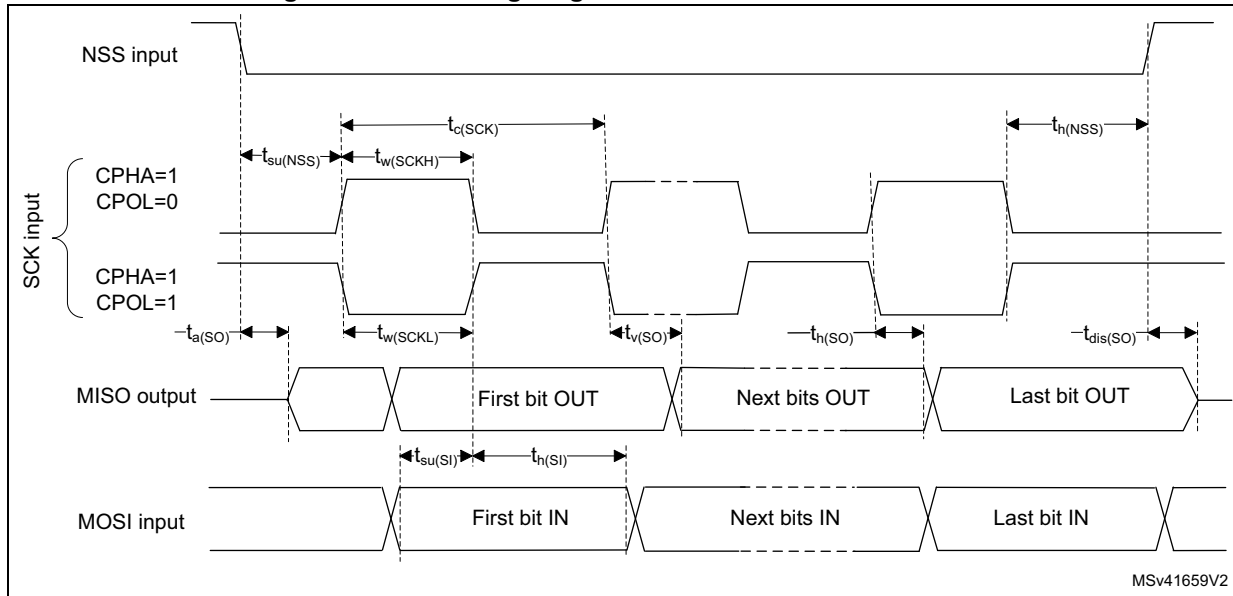
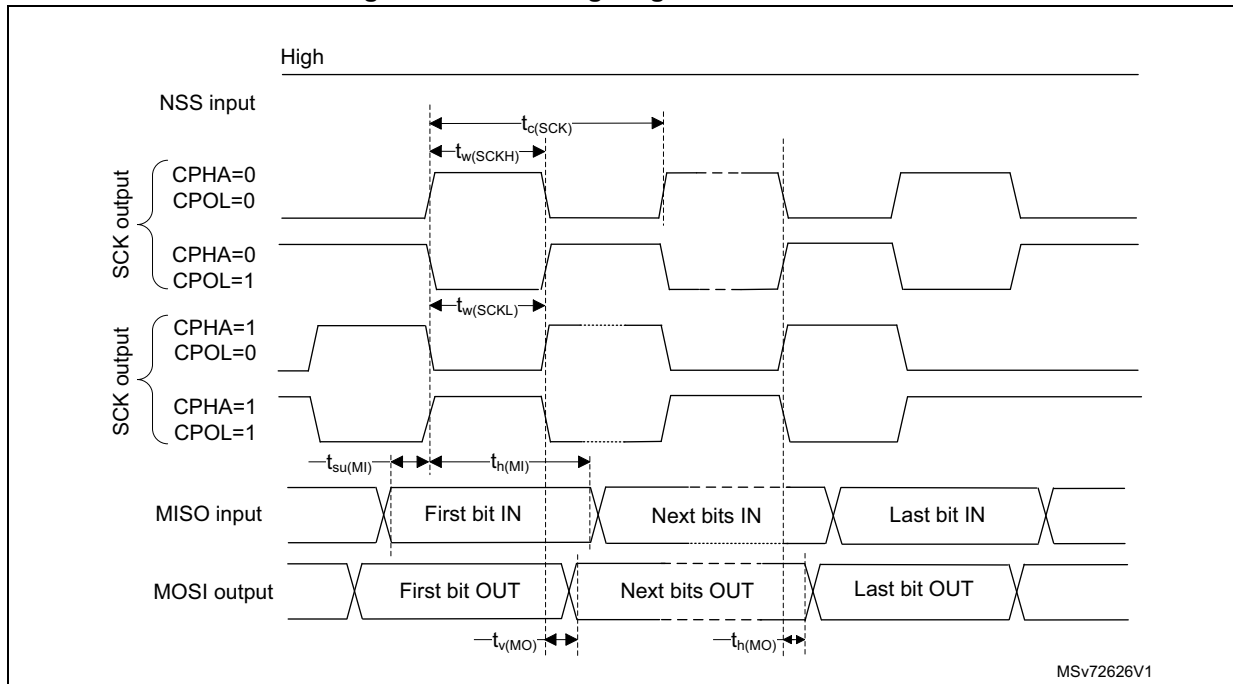

Figure 33. SPI timing diagram - master mode



MSv72626V1

Table 78. I²S characteristics⁽¹⁾

Symbol	Parameter	Conditions	Min	Max	Unit
f_{MCK}	I2S main clock output	$f_{MCK} = 256 \times F_s$; (F_s = audio sampling frequency) $F_{s_{min}} = 8 \text{ kHz}$; $F_{s_{max}} = 192 \text{ kHz}$;	2.048	49.152	MHz
f_{CK}	I2S clock frequency	Master data	-	$64 \times F_s$	MHz
		Slave data	-	$64 \times F_s$	
D_{CK}	I2S clock frequency duty cycle	Slave receiver	30	70	%
$t_{v(WS)}$	WS valid time	Master mode	-	8	ns
$t_{h(WS)}$	WS hold time	Master mode	2	-	ns
$t_{su(WS)}$	WS setup time	Slave mode	4	-	ns
$t_{h(WS)}$	WS hold time	Slave mode	2	-	ns
$t_{su(SD_MR)}$	Data input setup time	Master receiver	4	-	ns
$t_{su(SD_SR)}$		Slave receiver	5	-	ns
$t_{h(SD_MR)}$	Data input hold time	Master receiver	4.5	-	ns
$t_{h(SD_SR)}$		Slave receiver	2	-	ns
$t_{v(SD_ST)}$	Data output valid time - slave transmitter	after enable edge; $2.7 < V_{DD} < 3.6V$	-	16	ns
		after enable edge; $1.65 < V_{DD} < 3.6V$	-	23	
$t_{v(SD_MT)}$	Data output valid time - master transmitter	after enable edge	-	5.5	ns

Table 78. I²S characteristics⁽¹⁾ (continued)

Symbol	Parameter	Conditions	Min	Max	Unit
$t_{h(SD_ST)}$	Data output hold time - slave transmitter	after enable edge	8	-	ns
$t_{h(SD_MT)}$	Data output hold time - master transmitter	after enable edge	1	-	ns

1. Based on characterization results, not tested in production.

Figure 34. I²S slave timing diagram (Philips protocol)

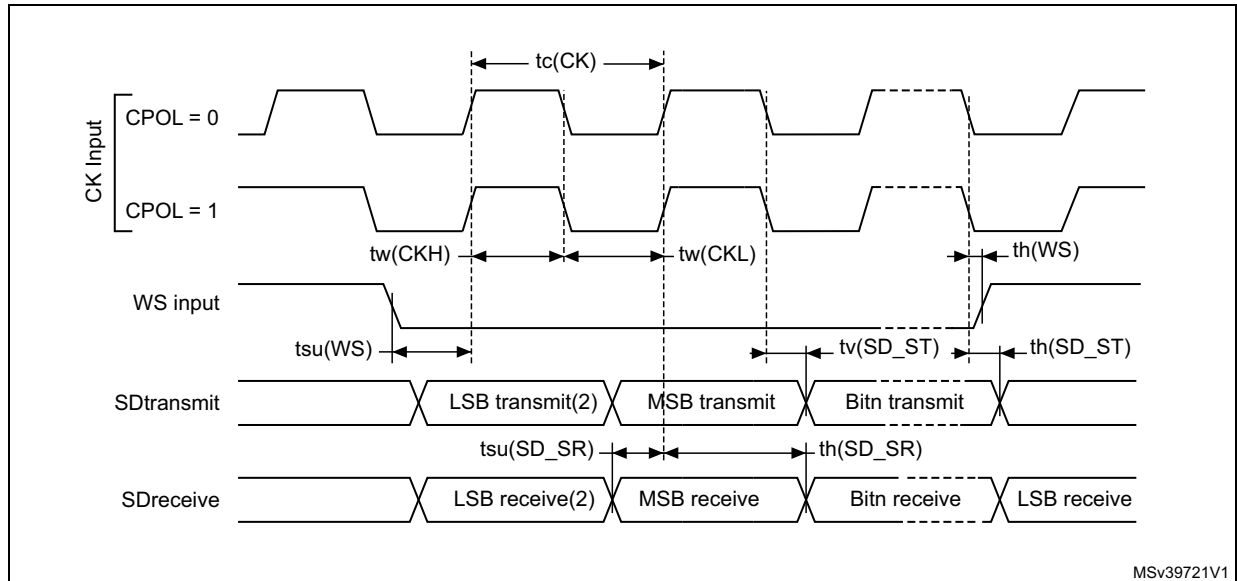

1. Measurement points are done at CMOS levels: $0.3 V_{DDIO1}$ and $0.7 V_{DDIO1}$.
2. LSB transmit/receive of the previously transmitted byte. No LSB transmit/receive is sent before the first byte.

Figure 35. I²S master timing diagram (Philips protocol)

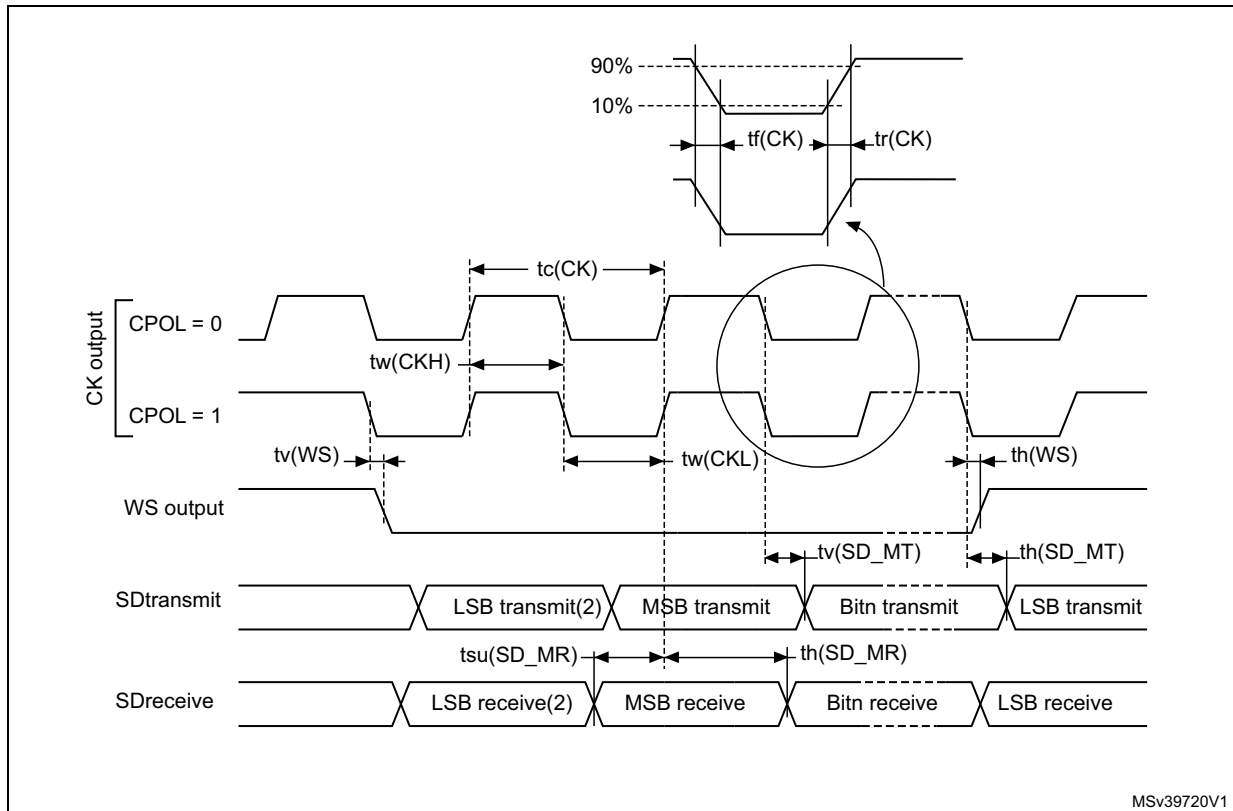

1. Based on characterization results, not tested in production.
2. LSB transmit/receive of the previously transmitted byte. No LSB transmit/receive is sent before the first byte.

USART (SPI mode) characteristics

Unless otherwise specified, the parameters given in [Table 79](#) for USART are derived from tests performed under the ambient temperature, f_{PCLKx} frequency and supply voltage conditions summarized in [Table 24: General operating conditions](#). The additional general conditions are:

- OSPEEDRy[1:0] set to 10 (output speed)
- capacitive load C = 30 pF
- measurement points at CMOS levels: $0.5 \times V_{DD}$

Refer to [Section 5.3.14: I/O port characteristics](#) for more details on the input/output alternate function characteristics (NSS, CK, TX, and RX for USART).

Table 79. USART characteristics in SPI mode

Symbol	Parameter	Conditions	Min	Typ	Max	Unit
f_{CK}	USART clock frequency	Master mode	-	-	8	MHz
		Slave mode	-	-	21	
$t_{su(NSS)}$	NSS setup time	Slave mode	$T_{ker}^{(1)} + 2$	-	-	ns
$t_h(NSS)$	NSS hold time	Slave mode	2	-	-	ns

Table 79. USART characteristics in SPI mode

Symbol	Parameter	Conditions	Min	Typ	Max	Unit
$t_{w(CKH)}$	CK high time	Master mode	$\frac{1}{f_{CK}} / 2 - 1$	$1 / f_{CK} / 2$	$\frac{1}{f_{CK}} / 2 + 1$	ns
$t_{w(CKL)}$	CK low time					ns
$t_{su(RX)}$	Data input setup time	Master mode	$T_{ker}^{(1)} + 2$	-	-	ns
		Slave mode	4	-	-	ns
$t_{h(RX)}$	Data input hold time	Master mode	1	-	-	ns
		Slave mode	0.5	-	-	ns
$t_{v(TX)}$	Data output valid time	Master mode	-	0.5	1	ns
		Slave mode	-	10	19	ns
$t_{h(TX)}$	Data output hold time	Master mode	0	-	-	ns
		Slave mode	7	-	-	ns

1. T_{ker} is the `usart_ker_ck_pres` clock period

Figure 36. USART timing diagram in SPI master mode

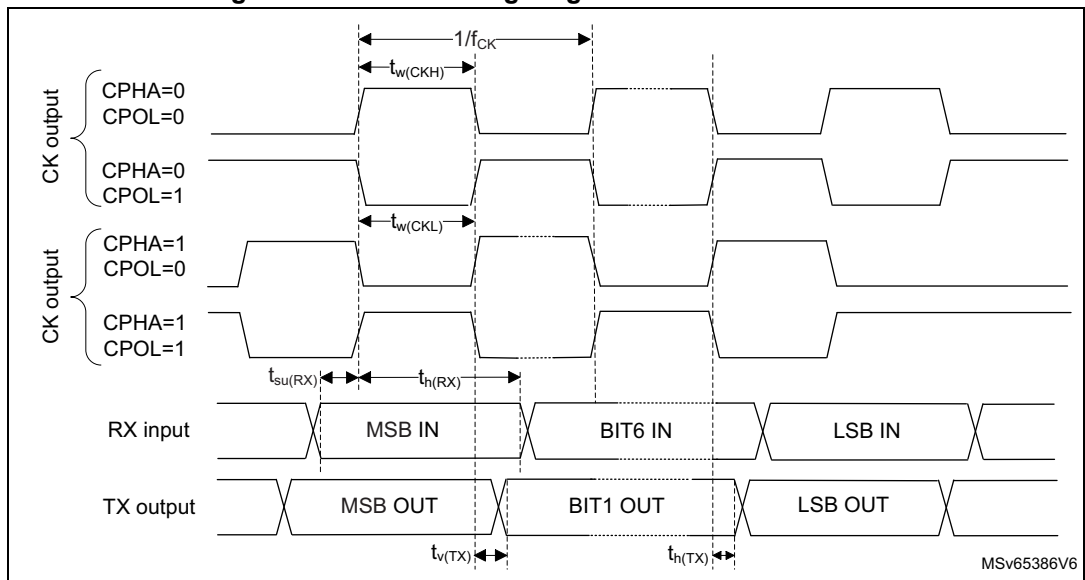
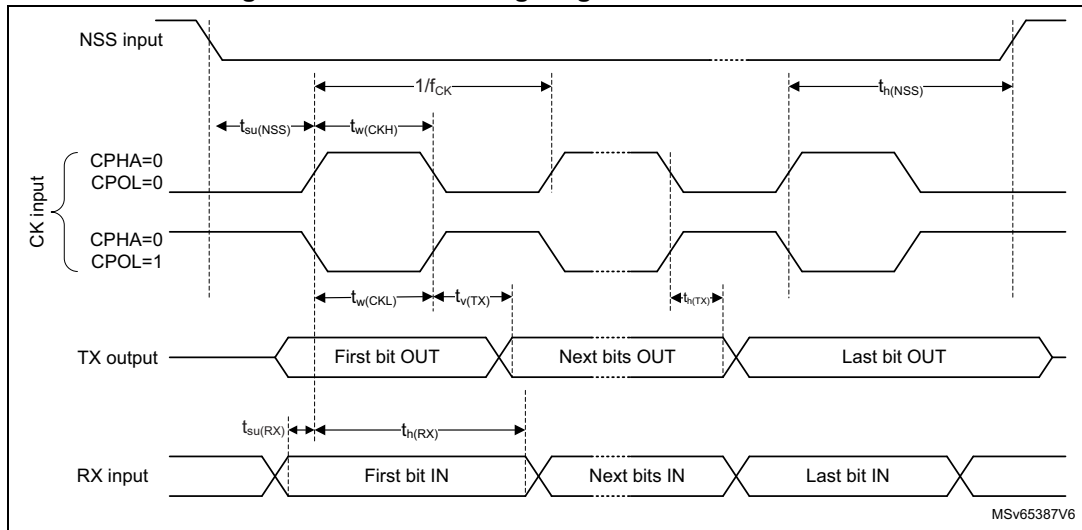

Figure 37. USART timing diagram in SPI slave mode



USB full speed (FS) characteristics

The STM32G0B1xB/xC/xE USB interface is fully compliant with the USB specification version 2.0 and Battery charging rev 1.2 (primary and secondary detection).

Table 80. USB FS electrical characteristics

Symbol	Parameter ⁽¹⁾	Conditions	Min ⁽²⁾	Typ	Max ⁽²⁾	Unit
V _{DDIO2}	USB full speed transceiver operating voltage	-	3.0 ⁽³⁾	-	3.6	V
t _{STARTUP}	USB transceiver startup time	-	-	-	1	μs
R _{PD}	Pull down resistor on PA11, PA12 (USB_FS_DP/DM)	V _{IN} = V _{DD}	14.25	-	24.8	kΩ
R _{PU}	Pull Up Resistor on PA12 (USB_FS_DP)	V _{IN} = V _{SS} , during idle	0.9	1.25	1.575	kΩ
	Pull Up Resistor on PA12 (USB_FS_DP)	V _{IN} = V _{SS} during reception	1.425	2.25	3.09	kΩ
V _{CRS}	Output signal crossover voltage	-	1.3	-	2.0	V
Z _{DRV}	Output driver impedance ⁽⁴⁾	Driving high or low	28	36	44	Ω

1. Specified by design. Not tested in production.
2. All the voltages are measured from the local ground potential.
3. The USB full speed transceiver functionality is ensured down to 2.7 V but not the full USB full speed electrical characteristics which are degraded in the 2.7-to-3.0 V V_{DDIO2} voltage range.
4. No external termination series resistors are required on DP (D+) and DM (D-) pins as the matching impedance is included in the embedded driver.

Figure 38. USB timings – definition of data signal rise and fall time

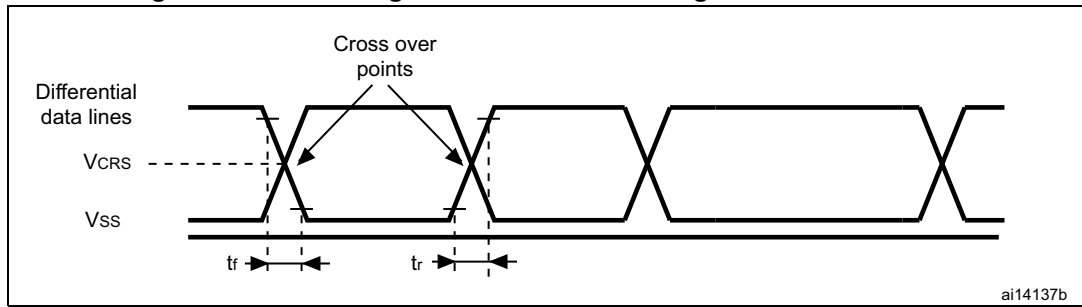

UCPD characteristics

UCPD1 and UCPD2 controllers comply with USB Type-C Rev.2 and USB Power Delivery Rev. 3.0 specifications.

Table 81. UCPD operating conditions

Symbol	Parameter	Conditions	Min	Typ	Max	Unit
V_{DD}	UCPD operating supply voltage	Sink mode only	3.0	3.3	3.6	V
		Sink and source mode	3.135	3.3	3.465	
V_{swing}	Output voltage swing	-	1.05	-	1.2	V
Z_{DRV}	Output driver impedance	Driving high or low	33	-	75	Ω

CAN (controller area network) interface

Refer to [Section 5.3.14: I/O port characteristics](#) for more details on the input/output alternate function characteristics (FDCANx_TX and FDCANx_RX).

6 Package information

In order to meet environmental requirements, ST offers these devices in different grades of ECOPACK packages, depending on their level of environmental compliance. ECOPACK specifications, grade definitions and product status are available at: www.st.com. ECOPACK is an ST trademark.

6.1 Device marking

Refer to technical note “Reference device marking schematics for STM32 microcontrollers and microprocessors” (TN1433) available on www.st.com, for the location of pin 1 / ball A1 as well as the location and orientation of the marking areas versus pin 1 / ball A1.

Parts marked as “ES”, “E” or accompanied by an engineering sample notification letter, are not yet qualified and therefore not approved for use in production. ST is not responsible for any consequences resulting from such use. In no event will ST be liable for the customer using any of these engineering samples in production. ST's Quality department must be contacted prior to any decision to use these engineering samples to run a qualification activity.

A WLCSP simplified marking example (if any) is provided in the corresponding package information subsection.

6.2 LQFP32 package information (5V)

This LQFP is a 32-pin, 7 x 7 mm, low-profile quad flat package.

Note: [Figure 39](#) is not to scale.

Refer to the notes section for the list of notes on [Figure 39](#) and [Table 82](#).

Figure 39. LQFP32 - Outline

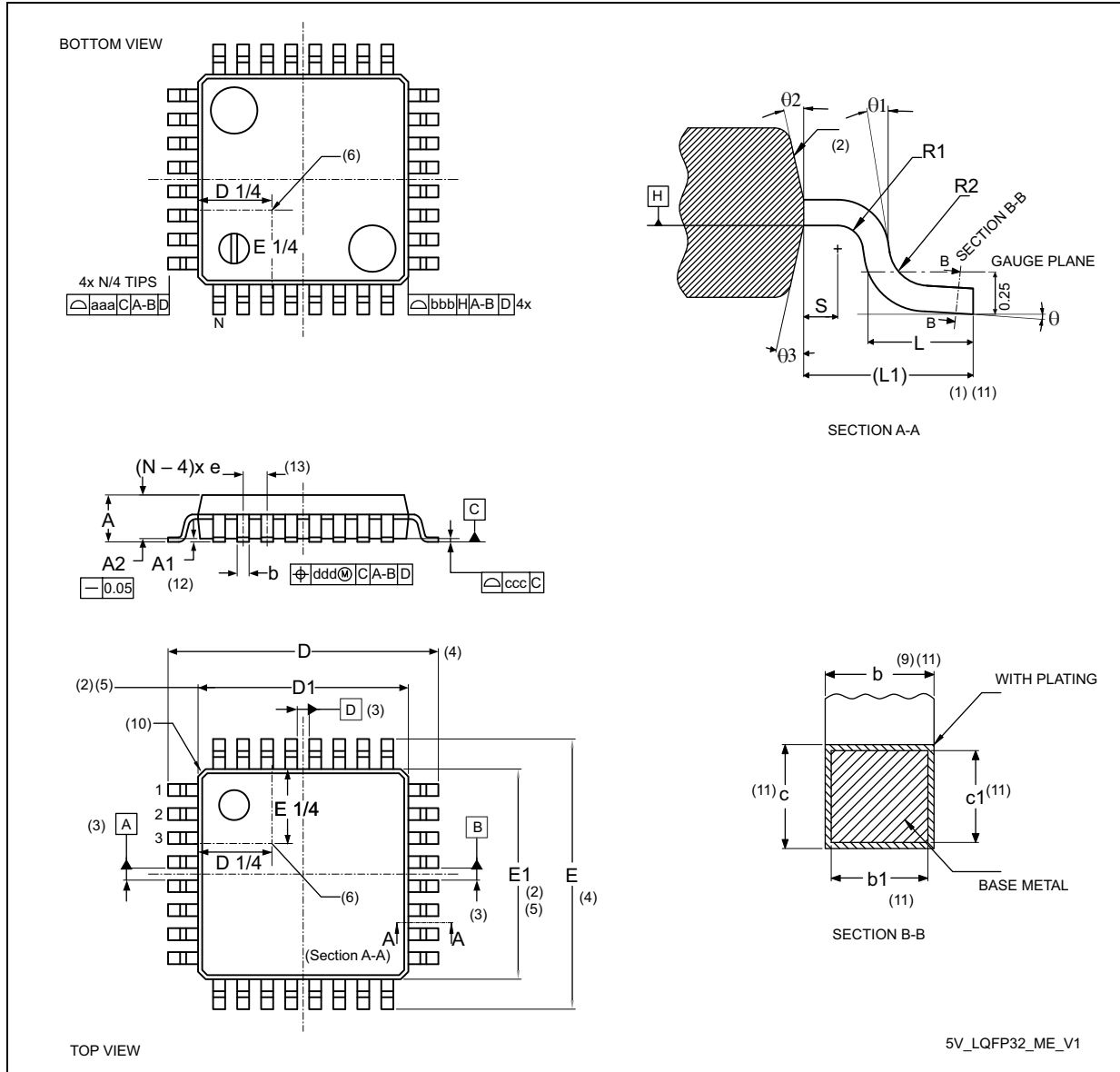

Table 82. LQFP32 - Mechanical data

Symbol	millimeters			inches ⁽¹⁴⁾		
	Min	Typ	Max	Min	Typ	Max
θ	0°	3.5°	7°	0°	3.5°	7°
θ_1	0°	-	-	0°	-	-
θ_2	10°	12°	14°	10°	12°	14°
θ_3	10°	12°	14°	10°	12°	14°
A	-	-	1.60	-	-	0.0630
A1 ⁽¹²⁾	0.05	-	0.15	0.0020	-	0.0059
A2	1.35	1.40	1.45	0.0531	0.0551	0.0571
b ⁽⁹⁾⁽¹¹⁾	0.30	0.37	0.45	0.0118	0.0146	0.0177
b1 ⁽¹¹⁾	0.30	0.35	0.40	0.0118	0.0128	0.0157
c ⁽¹¹⁾	0.09	-	0.20	0.0035	-	0.0079
c1 ⁽¹¹⁾	0.09	-	0.16	0.0035	-	0.0063
D ⁽⁴⁾	9.00 BSC			0.3543 BSC		
D1 ⁽²⁾⁽⁵⁾	7.00 BSC			0.2756 BSC		
e	0.80 BSC			0.0315 BSC		
E ⁽⁴⁾	9.00 BSC			0.3543 BSC		
E1 ⁽²⁾⁽⁵⁾	7.00 BSC			0.2756 BSC		
L	0.45	0.60	0.75	0.0177	0.0236	0.0295
L1	1.00 REF			0.0394 REF		
N ⁽¹³⁾	32					
R1	0.08	-	-	0.0031	-	-
R2	0.08	-	0.20	0.0031	-	0.0079
S	0.20	-	-	0.0079	-	-
aaa ⁽¹⁾⁽⁷⁾⁽¹⁵⁾	0.20			0.0079		
bbb ⁽¹⁾⁽⁷⁾⁽¹⁵⁾	0.20			0.0079		
ccc ⁽¹⁾⁽⁷⁾⁽¹⁵⁾	0.10			0.0039		
ddd ⁽¹⁾⁽⁷⁾⁽¹⁵⁾	0.20			0.0079		

Notes:

1. Dimensioning and tolerancing schemes conform to ASME Y14.5M-1994.
2. The top package body size may be smaller than the bottom package size by as much as 0.15 mm.
3. Datums A-B and D to be determined at datum plane H.
4. To be determined at the seating datum plane C.
5. Dimensions D1 and E1 do not include mold flash or protrusions. Allowable mold flash or protrusions is "0.25 mm" per side. D1 and E1 are maximum plastic body size dimensions including mold mismatch.
6. Details of pin 1 identifier are optional but must be located within the zone indicated.
7. All dimensions are in millimeters.
8. No intrusion is allowed inwards the leads.
9. Dimension b does not include a dambar protrusion. Allowable dambar protrusion shall not cause the lead width to exceed the maximum "b" dimension by more than 0.08 mm. Dambar cannot be located on the lower radius or the foot. The minimum space between the protrusion and an adjacent lead is 0.07 mm for 0.4 mm and 0.5 mm pitch packages.
10. The exact shape of each corner is optional.
11. These dimensions apply to the flat section of the lead between 0.10 mm and 0.25 mm from the lead tip.
12. A1 is defined as the distance from the seating plane to the lowest point on the package body.
13. N is the number of terminal positions for the specified body size.
14. Values in inches are converted from mm and rounded to four decimal digits.
15. Recommended values and tolerances.

Figure 40. LQFP32 – Footprint example

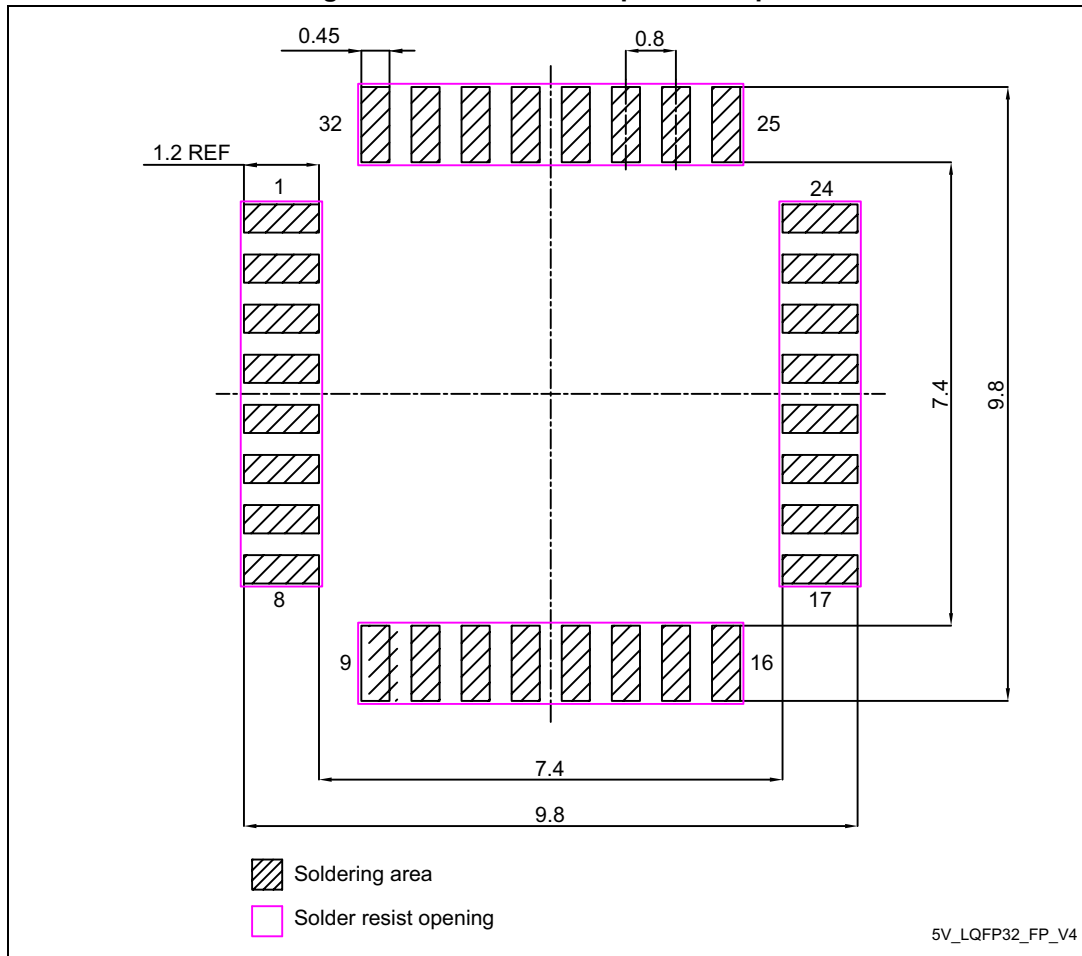

1. Dimensions are expressed in millimeters.

6.3 UFQFPN32 package information (A0B8)

This UFQFPN is a 32-pin, 5 x 5 mm, 0.5 mm pitch ultrathin fine pitch quad flat package.

Note: [Figure 41](#) and [Figure 42](#) are not to scale.
Refer to the notes section for the list of notes on [Figure 41](#), [Table 83](#), and [Table 84](#).

Figure 41. UFQFPN32 - Outline

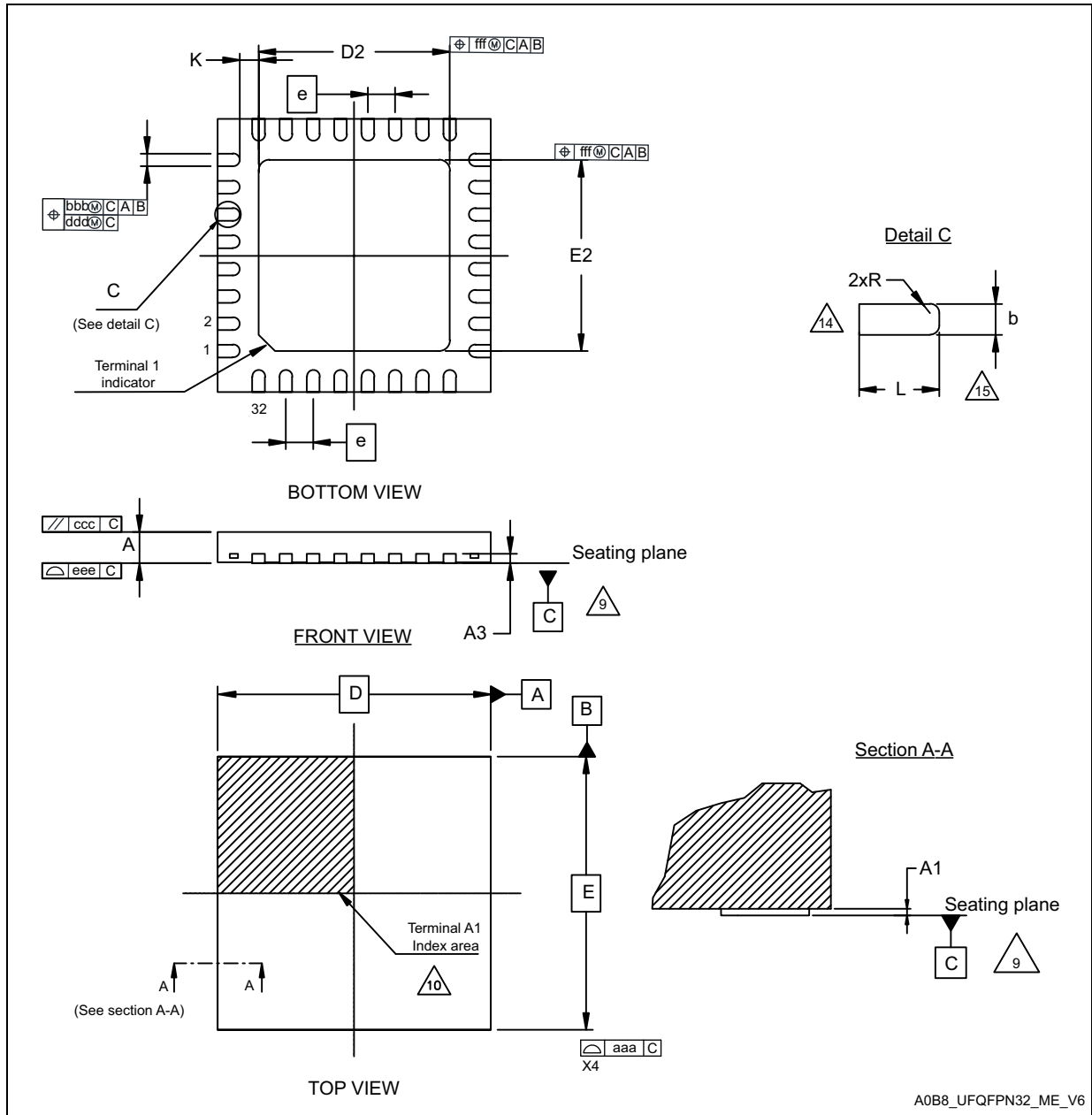

Table 83. UFQFPN32 - Mechanical data

Symbol	Millimeters			Inches ⁽⁸⁾		
	Min	Typ	Max	Min	Typ	Max
A ⁽²⁾⁽³⁾	0.50	0.55	0.60	0.0197	0.0217	0.0236
A1 ⁽⁴⁾	0.00	-	0.05	0.000	-	0.0020
b ⁽⁶⁾⁽¹⁵⁾	0.18	0.25	0.30	0.0071	0.0098	0.0118
D ⁽⁷⁾	5.00 BSC			0.1969 BSC		
D2	3.40	3.50	3.60	0.1339	0.1378	0.1417
E ⁽⁷⁾	5.00 BSC			0.1969 BSC		
E2	3.40	3.50	3.60	0.1339	0.1378	0.1417
e	0.50 BSC			0.0197 BSC		
N ⁽¹²⁾	32					
L ⁽¹⁵⁾	0.30	-	0.50	0.0118	-	0.0197
R	0.09	-	-	0.0035	-	-

Table 84. Tolerance of form and position

Symbol	Millimeters	Inches ⁽⁸⁾
aaa	0.15	0.0059
bbb	0.10	0.0039
ccc	0.10	0.0039
ddd	0.05	0.0020
eee	0.08	0.0315
fff	0.10	0.0039

Notes:

1. Dimensioning and tolerancing schemes conform to ASME Y14.5M-2018 except for European.
2. UFQFPN stands for ultra-thin fine pitch quad flat package no lead: $A \leq 0.60$ mm / Fine pitch $e \leq 1.00$ mm.
3. The profile height, A, is the distance from the seating plane to the highest point on the package. It is measured perpendicular to the seating plane.
4. A1 is the vertical distance from the bottom surface of the plastic body to the nearest metallized package feature.
5. A3 is the distance from the seating plane to the upper surface of the terminals.
6. Dimension b applies to metallized terminal. If the terminal has the optional radius on the other end of the terminal, the dimension b should not be measured in that radius area.
7. BSC stands for BASIC dimensions. It corresponds to the nominal value and has no tolerance.
8. Values in inches are converted from millimeters and rounded to four decimal digits.
9. Primary datum C is defined by the plane established by the contact points of three or more solder balls that support the device when it is placed on top of a planar surface.
10. Terminal A1 identifier and terminal numbering convention must conform to JEP95 SPP-002. Terminal A1 identifier must be located within the zone indicated on the outline drawing. Topside terminal A1 indicator may be a molded, or metallized feature. Optional indicator on bottom surface may be a molded, marked, or metallized feature.
11. ddd coplanarity zone applies to the exposed pad as well as the terminals.
12. N represents the total number of terminals.
13. K gives the minimum separation between any two terminals or the terminals and the edges of the exposed metal heat feature.
14. The inner edge of corner terminals may be chamfered or rounded to achieve minimum gap k. This feature should not affect the terminal width b, which is measured L/2 from the edge of the package body.
15. Dimension b and L are measured at the terminal planting surface.

Table 85. LQFP48 - Mechanical data

Symbol	millimeters			inches ⁽¹⁴⁾		
	Min	Typ	Max	Min	Typ	Max
A	-	-	1.60	-	-	0.0630
A1 ⁽¹²⁾	0.05	-	0.15	0.0020	-	0.0059
A2	1.35	1.40	1.45	0.0531	0.0551	0.0571
b ⁽⁹⁾⁽¹¹⁾	0.17	0.22	0.27	0.0067	0.0087	0.0106
b1 ⁽¹¹⁾	0.17	0.20	0.23	0.0067	0.0079	0.0090
c ⁽¹¹⁾	0.09	-	0.20	0.0035	-	0.0079
c1 ⁽¹¹⁾	0.09	-	0.16	0.0035	-	0.0063
D ⁽⁴⁾	9.00 BSC			0.3543 BSC		
D1 ⁽²⁾⁽⁵⁾	7.00 BSC			0.2756 BSC		
E ⁽⁴⁾	9.00 BSC			0.3543 BSC		
E1 ⁽²⁾⁽⁵⁾	7.00 BSC			0.2756 BSC		
e	0.50 BSC			0.1970 BSC		
L	0.45	0.60	0.75	0.0177	0.0236	0.0295
L1	1.00 REF			0.0394 REF		
N ⁽¹³⁾	48					
θ	0°	3.5°	7°	0°	3.5°	7°
θ1	0°	-	-	0°	-	-
θ2	10°	12°	14°	10°	12°	14°
θ3	10°	12°	14°	10°	12°	14°
R1	0.08	-	-	0.0031	-	-
R2	0.08	-	0.20	0.0031	-	0.0079
S	0.20	-	-	0.0079	-	-
aaa ⁽¹⁾⁽⁷⁾	0.20			0.0079		
bbb ⁽¹⁾⁽⁷⁾	0.20			0.0079		
ccc ⁽¹⁾⁽⁷⁾	0.08			0.0031		
ddd ⁽¹⁾⁽⁷⁾	0.08			0.0031		

Notes:

1. Dimensioning and tolerancing schemes conform to ASME Y14.5M-1994.
2. The Top package body size may be smaller than the bottom package size by as much as 0.15 mm.
3. Datums A-B and D to be determined at datum plane H.
4. To be determined at seating datum plane C.
5. Dimensions D1 and E1 do not include mold flash or protrusions. Allowable mold flash or protrusions is "0.25 mm" per side. D1 and E1 are Maximum plastic body size dimensions including mold mismatch.
6. Details of pin 1 identifier are optional but must be located within the zone indicated.
7. All Dimensions are in millimeters.
8. No intrusion allowed inwards the leads.
9. Dimension "b" does not include dambar protrusion. Allowable dambar protrusion shall not cause the lead width to exceed the maximum "b" dimension by more than 0.08 mm. Dambar cannot be located on the lower radius or the foot. Minimum space between protrusion and an adjacent lead is 0.07 mm for 0.4 mm and 0.5 mm pitch packages.
10. Exact shape of each corner is optional.
11. These dimensions apply to the flat section of the lead between 0.10 mm and 0.25 mm from the lead tip.
12. A1 is defined as the distance from the seating plane to the lowest point on the package body.
13. "N" is the number of terminal positions for the specified body size.
14. Values in inches are converted from mm and rounded to 4 decimal digits.
15. Drawing is not to scale.

Figure 44. LQFP48 - Footprint example

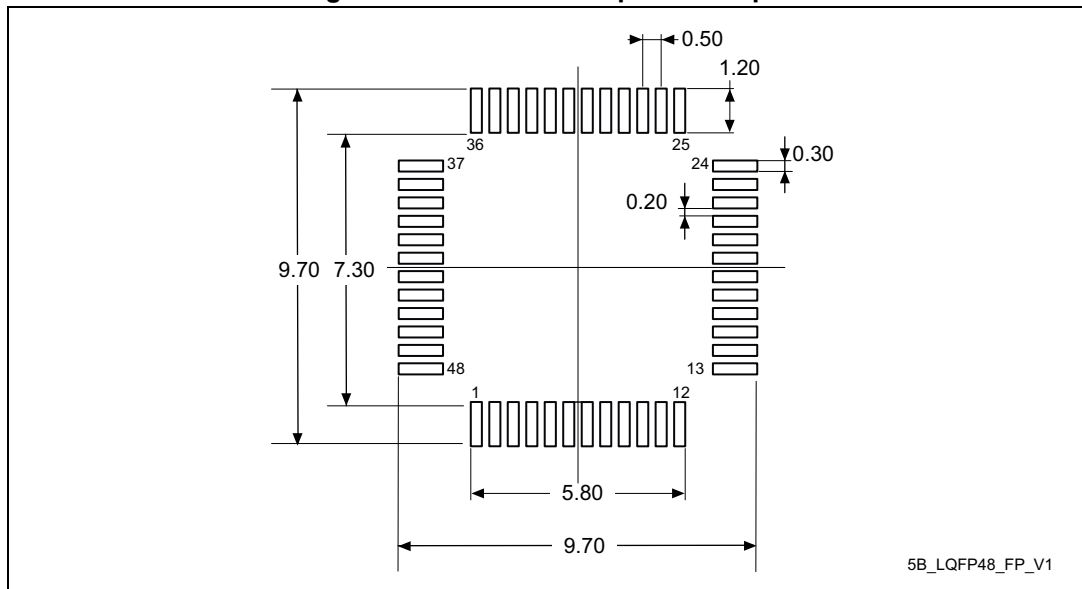

1. Dimensions are expressed in millimeters.

6.5 UFQFPN48 package information (A0B9)

This UFQFPN is a 48-lead, 7 x 7 mm, 0.5 mm pitch, ultra thin fine pitch quad flat package.

Figure 45. UFQFPN48 – Outline

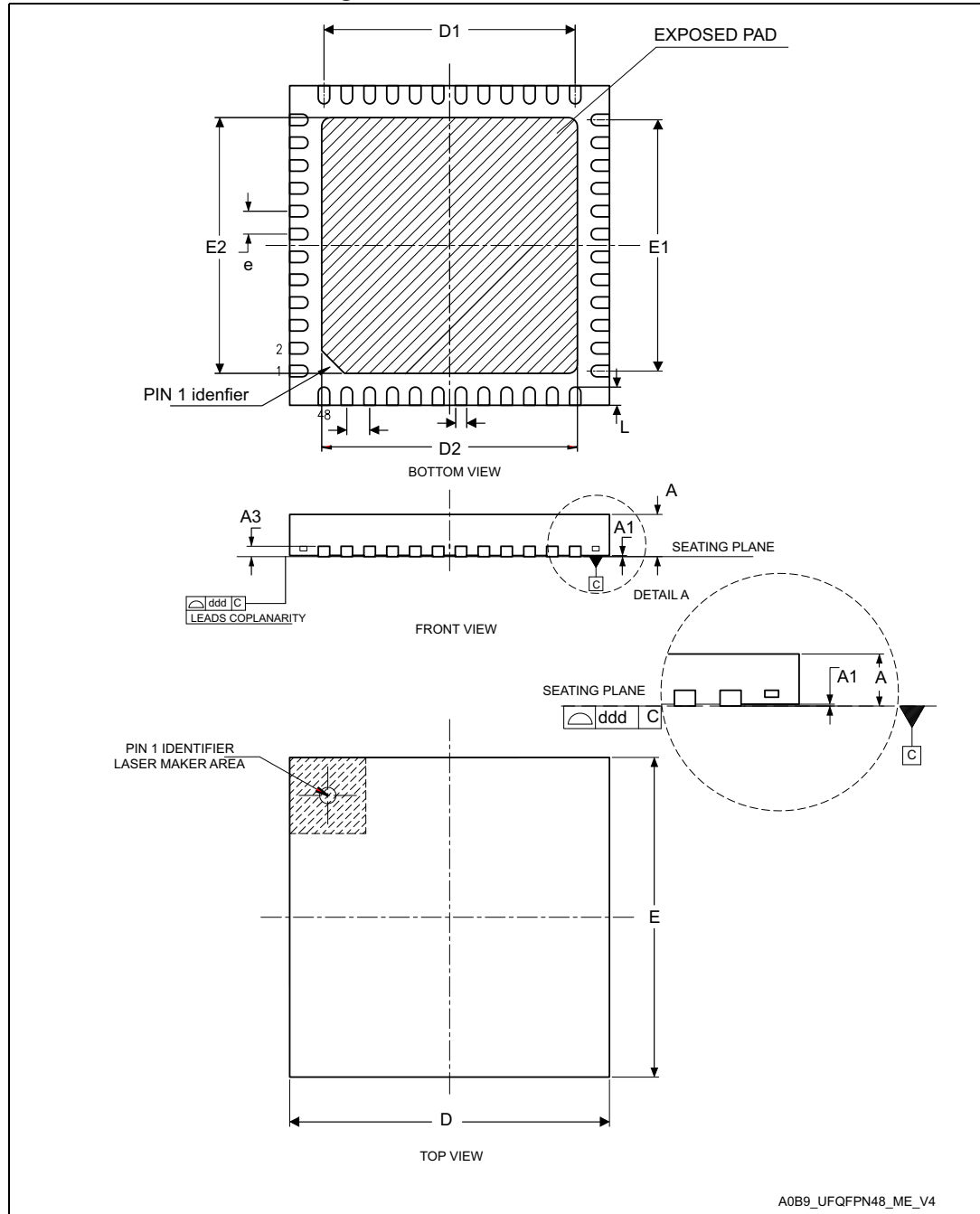

1. Drawing is not to scale.
2. All leads/pads should also be soldered to the PCB to improve the lead/pad solder joint life.
3. There is an exposed die pad on the underside of the UFQFPN48 package. It is recommended to connect and solder this back-side pad to PCB ground.

6.6 WLCSP52 package information (B0BG)

This WLCSP is a 52 balls, 3.15 x 3.09 mm, 0.4 mm pitch, wafer level chip scale package.

Figure 47. WLCSP52 - Outline

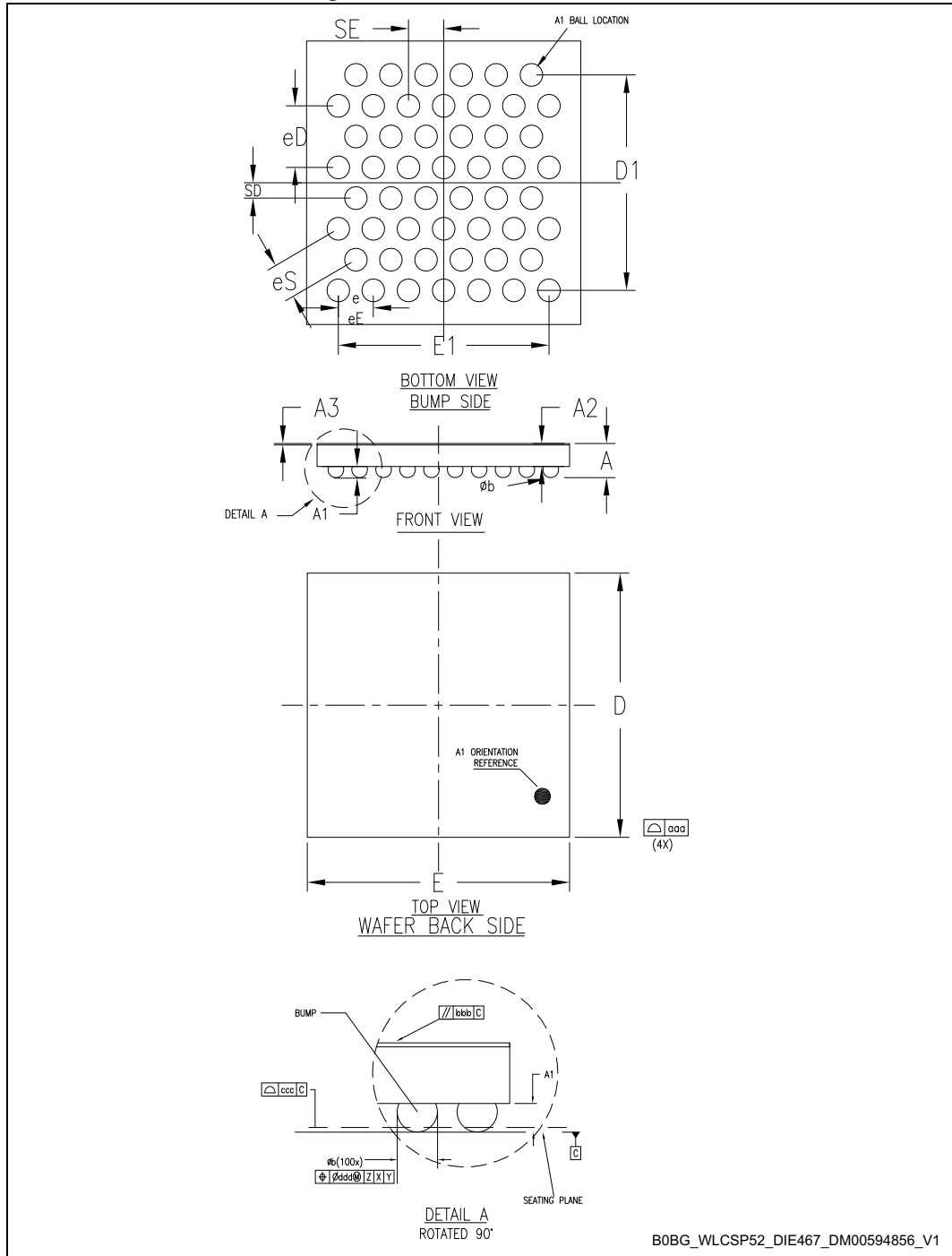

Note: The drawing is not to scale.



Table 87. WLCSP52 - Mechanical data

Symbol ⁽¹⁾	Millimeters			Inches ⁽²⁾		
	Min	Typ	Max	Min	Typ	Max
A ⁽³⁾	-	-	0.58	-	-	0.0228
A1 ⁽⁴⁾	0.13	-	-	0.0051	-	-
A2	-	0.38	-	-	0.0010	-
A3	-	0.025	-	-	0.001	-
b ⁽⁵⁾	0.23	0.26	0.28	0.0091	0.0102	0.0110
D ⁽⁶⁾	3.15 BSC			0.1240 BSC		
E ⁽⁶⁾	3.09 BSC			0.1217 BSC		
E1 ⁽⁶⁾	2.4 BSC			0.0945 BSC		
eD ⁽⁶⁾⁽⁷⁾	0.69 BSC			0.0272 BSC		
eE ⁽⁶⁾⁽⁷⁾	0.4 BSC			0.0157 BSC		
eS ⁽⁶⁾⁽⁷⁾	0.4 BSC			0.0157 BSC		
N ⁽⁸⁾	52					
SD ⁽⁶⁾⁽⁹⁾	0.17 BSC			0.0067 BSC		
SE ⁽⁶⁾⁽⁹⁾	0.4 BSC			0.0157 BSC		

1. Dimensioning and tolerancing schemes are conform to ASME Y14.5M-2018 apart European projection.
2. Values in inches are converted from millimeters and rounded to four decimal digits.
3. The profile height, A, is the distance from the seating plane to the highest point on the package. It is measured perpendicular to the seating plane.
4. A1 is defined as the distance from the seating plane to the lowest point on the package body for CSP or the distance from the seating plane to the land for CSP.
5. Measured at the maximum size of the terminal (ball, land) in a plane parallel to datum C.
6. BSC stands for basic dimensions. It corresponds to the nominal value and has no linear tolerance.
7. e indicates the grid pitch of the solder balls or lands.
8. N represents the total number of balls/lands.
9. Basic dimensions SD and SE are defining the balls/lands matrix position with respect to datums A and B.

Table 88. WLCSP52 - Tolerance of form and position

Symbol ⁽¹⁾	Millimeters			Inches ⁽²⁾		
	Min	Typ	Max	Typ	Min	Max
aaa ⁽³⁾	0.03			0.0012		
bbb ⁽⁴⁾	0.06			0.0024		
ccc ⁽⁵⁾	0.03			0.0012		
ddd ⁽⁶⁾	0.015			0.0006		

1. Dimensioning and tolerancing schemes are conform to ASME Y14.5M-2018 apart European projection.
2. Values in inches are converted from millimeters and rounded to four decimal digits.
3. The profile tolerance controls the location and orientation of the sides of the package.

4. The parallelism tolerance controls the orientation of the top surface of the package with respect to datum C.
5. The profile tolerance controls the location of the crowns of the balls/lands with respect to datum C. Terminal (ball, land) coplanarity.
6. The tolerance of position that controls the location of the pattern of balls/lands with respect to datum's A and B.

Figure 48. WLCSP52 - Footprint example

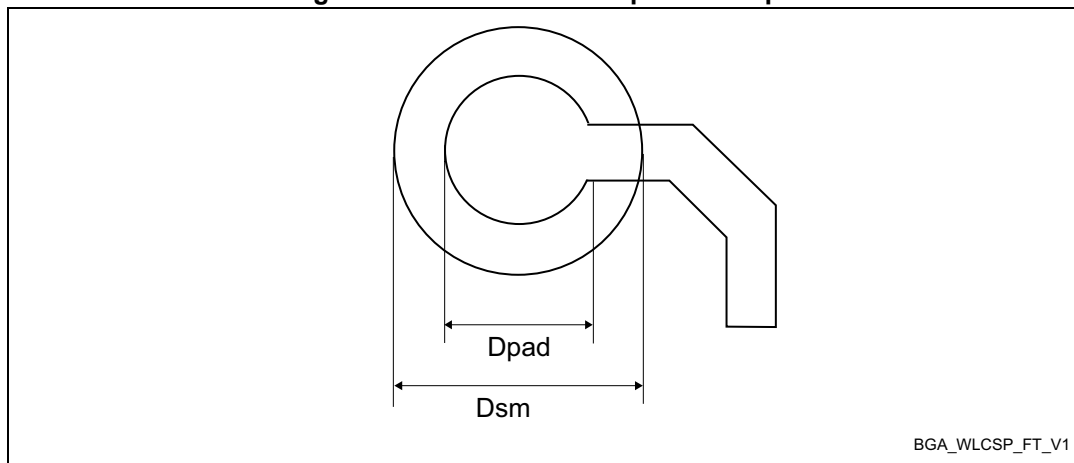

Table 89. WLCSP52 - Example of PCB design rules

Dimension	Values
Pitch	0.4 mm
D_{pad}	0,225 mm
D_{sm}	0.290 mm typ. (depends on soldermask registration tolerance)
Stencil opening	0.250 mm
Stencil thickness	0.100 mm

Device marking

The following figure gives an example of topside marking orientation versus ball A1 identifier location.

The printed markings may differ depending on the supply chain.

Other optional marking or inset/upset marks that identify the parts throughout supply chain operations, are not indicated below.

Figure 49. WLCSP52 package marking example

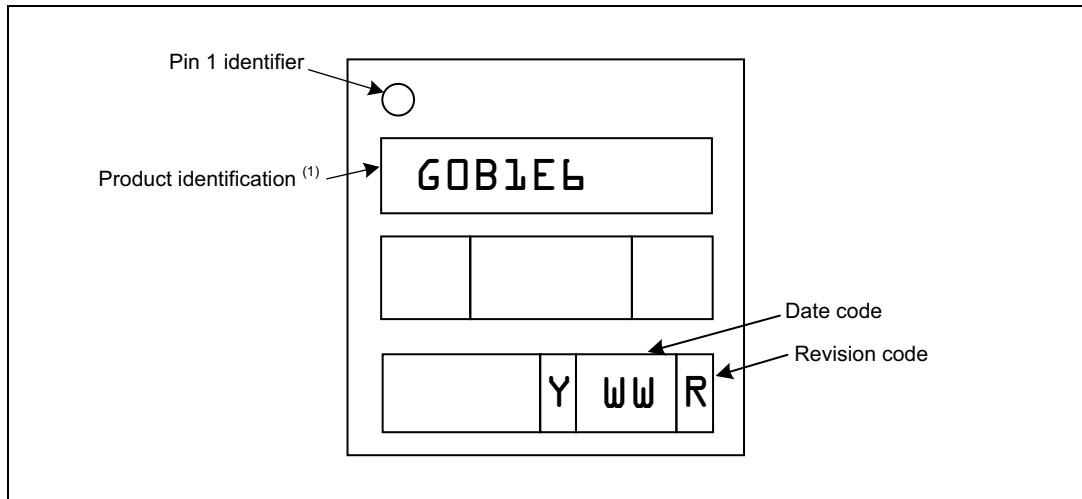

6.7 LQFP64 package information (5W)

This LQFP is a 64-pin, 10 x 10 mm low-profile quad flat package.

Figure 50. LQFP64 - Outline⁽¹⁵⁾

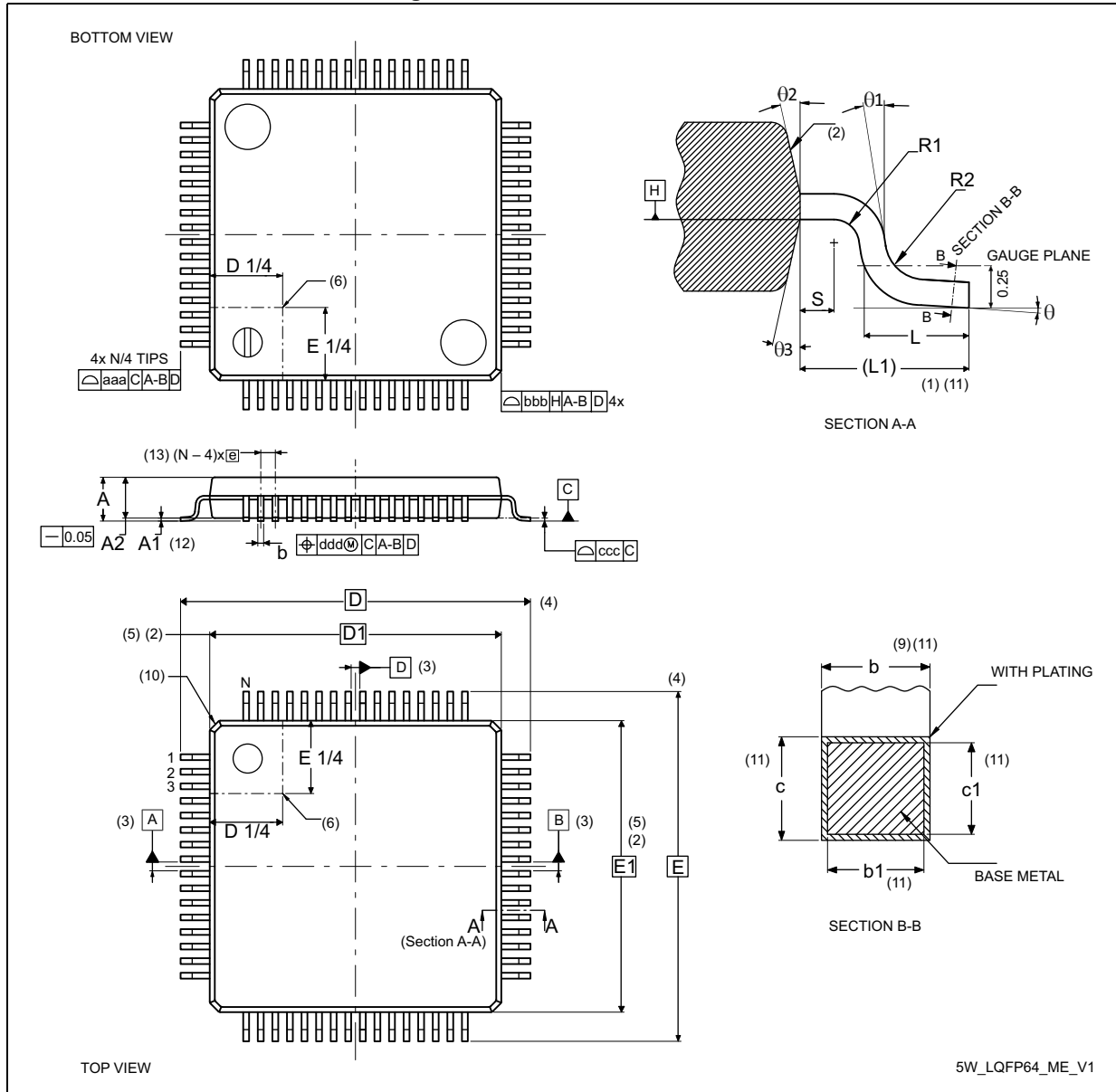

Table 90. LQFP64 - Mechanical data

Symbol	millimeters			inches ⁽¹⁴⁾		
	Min	Typ	Max	Min	Typ	Max
A	-	-	1.60	-	-	0.0630
A1 ⁽¹²⁾	0.05	-	0.15	0.0020	-	0.0059
A2	1.35	1.40	1.45	0.0531	0.0551	0.0570
b ⁽⁹⁾⁽¹¹⁾	0.17	0.22	0.27	0.0067	0.0087	0.0106
b1 ⁽¹¹⁾	0.17	0.20	0.23	0.0067	0.0079	0.0091
c ⁽¹¹⁾	0.09	-	0.20	0.0035	-	0.0079
c1 ⁽¹¹⁾	0.09	-	0.16	0.0035	-	0.0063
D ⁽⁴⁾	12.00 BSC			0.4724 BSC		
D1 ⁽²⁾⁽⁵⁾	10.00 BSC			0.3937 BSC		
E ⁽⁴⁾	12.00 BSC			0.4724 BSC		
E1 ⁽²⁾⁽⁵⁾	10.00 BSC			0.3937 BSC		
e	0.50 BSC			0.1970 BSC		
L	0.45	0.60	0.75	0.0177	0.0236	0.0295
L1	1.00 REF			0.0394 REF		
N ⁽¹³⁾	64					
θ	0°	3.5°	7°	0°	3.5°	7°
θ1	0°	-	-	0°	-	-
θ2	10°	12°	14°	10°	12°	14°
θ3	10°	12°	14°	10°	12°	14°
R1	0.08	-	-	0.0031	-	-
R2	0.08	-	0.20	0.0031	-	0.0079
S	0.20	-	-	0.0079	-	-
aaa ⁽¹⁾	0.20			0.0079		
bbb ⁽¹⁾	0.20			0.0079		
ccc ⁽¹⁾	0.08			0.0031		
ddd ⁽¹⁾	0.08			0.0031		

Notes:

1. Dimensioning and tolerancing schemes conform to ASME Y14.5M-1994.
2. The Top package body size may be smaller than the bottom package size by as much as 0.15 mm.
3. Datums A-B and D to be determined at datum plane H.
4. To be determined at seating datum plane C.
5. Dimensions D1 and E1 do not include mold flash or protrusions. Allowable mold flash or protrusions is "0.25 mm" per side. D1 and E1 are Maximum plastic body size dimensions including mold mismatch.
6. Details of pin 1 identifier are optional but must be located within the zone indicated.
7. All Dimensions are in millimeters.
8. No intrusion allowed inwards the leads.
9. Dimension "b" does not include dambar protrusion. Allowable dambar protrusion shall not cause the lead width to exceed the maximum "b" dimension by more than 0.08 mm. Dambar cannot be located on the lower radius or the foot. Minimum space between protrusion and an adjacent lead is 0.07 mm for 0.4 mm and 0.5 mm pitch packages.
10. Exact shape of each corner is optional.
11. These dimensions apply to the flat section of the lead between 0.10 mm and 0.25 mm from the lead tip.
12. A1 is defined as the distance from the seating plane to the lowest point on the package body.
13. "N" is the number of terminal positions for the specified body size.
14. Values in inches are converted from mm and rounded to 4 decimal digits.
15. Drawing is not to scale.

6.8 UFBGA64 package information (A019)

This UFBGA is a 64-ball, 5 x 5 mm, 0.5 mm pitch ultra profile fine pitch ball grid array package.

Note: See list of notes in the notes section.

Figure 51. UFBGA64 – Outline⁽¹³⁾

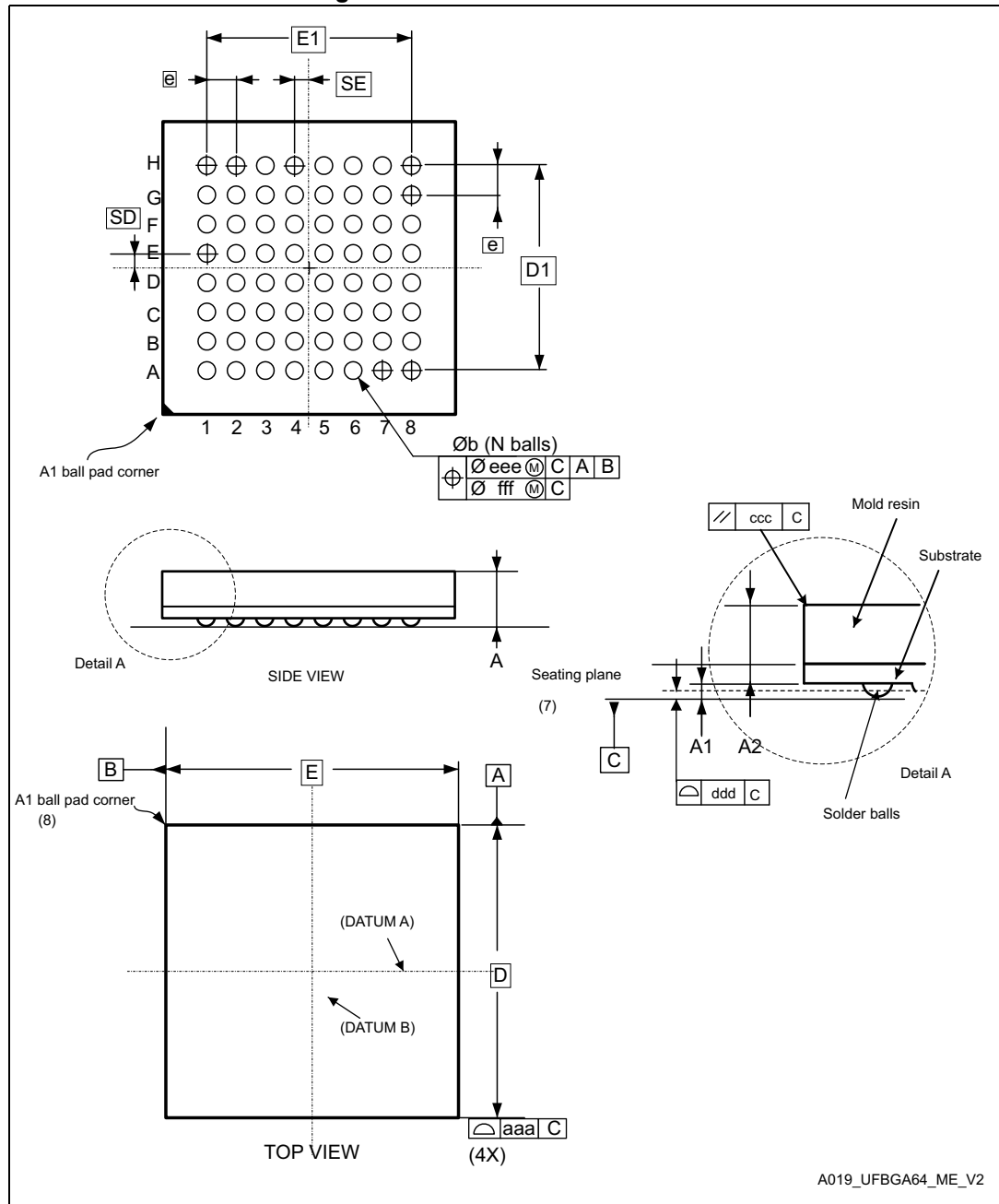

Table 91. UFBGA64 – Mechanical data

Symbol	millimeters ⁽¹⁾			inches ⁽¹²⁾		
	Min	Typ	Max	Min	Typ	Max
A ⁽²⁾⁽³⁾	-	-	0.60	-	-	0.0236
A1 ⁽⁴⁾	0.05	-	-	0.0020	-	-
A2	-	0.43	-	-	0.0169	-
b ⁽⁵⁾	0.23	0.28	0.33	0.0090	0.0110	0.0130
D ⁽⁶⁾	5.00 BSC			0.1969 BSC		
D1	3.50 BSC			0.1378 BSC		
E	5.00 BSC			0.1969 BSC		
E1	3.50 BSC			0.1378 BSC		
e ⁽⁹⁾	0.50 BSC			0.0197 BSC		
N ⁽¹⁰⁾	64					
SD ⁽¹¹⁾	0.25 BSC			0.0098 BSC		
SE ⁽¹¹⁾	0.25 BSC			0.0098 BSC		
aaa	0.15			0.0059		
ccc	0.20			0.0079		
ddd	0.08			0.0031		
eee	0.15			0.0059		
fff	0.05			0.0020		

Notes:

1. Dimensioning and tolerancing schemes conform to ASME Y14.5M-2009 apart European projection.
2. UFBGA stands for ultra profile fine pitch ball grid array: $0.5 \text{ mm} < A \leq 0.65 \text{ mm}$ / fine pitch $e < 1.00 \text{ mm}$.
3. The profile height, A, is the distance from the seating plane to the highest point on the package. It is measured perpendicular to the seating plane.
4. A1 is defined as the distance from the seating plane to the lowest point on the package body.
5. Dimension b is measured at the maximum diameter of the terminal (ball) in a plane parallel to primary datum C.
6. BSC stands for BASIC dimensions. It corresponds to the nominal value and has no tolerance. For tolerances refer to form and position table. On the drawing these dimensions are framed.
7. Primary datum C is defined by the plane established by the contact points of three or more solder balls that support the device when it is placed on top of a planar surface.
8. The terminal (ball) A1 corner must be identified on the top surface of the package by using a corner chamfer, ink or metalized markings, or other feature of package body or

- integral heat slug. A distinguish feature is allowable on the bottom surface of the package to identify the terminal A1 corner. Exact shape of each corner is optional.
9. e represents the solder ball grid pitch.
 10. N represents the total number of balls on the BGA.
 11. Basic dimensions SD and SE are defined with respect to datums A and B. It defines the position of the centre ball(s) in the outer row or column of a fully populated matrix.
 12. Values in inches are converted from mm and rounded to 4 decimal digits.
 13. Drawing is not to scale.

Figure 52. UFBGA64 – Footprint example

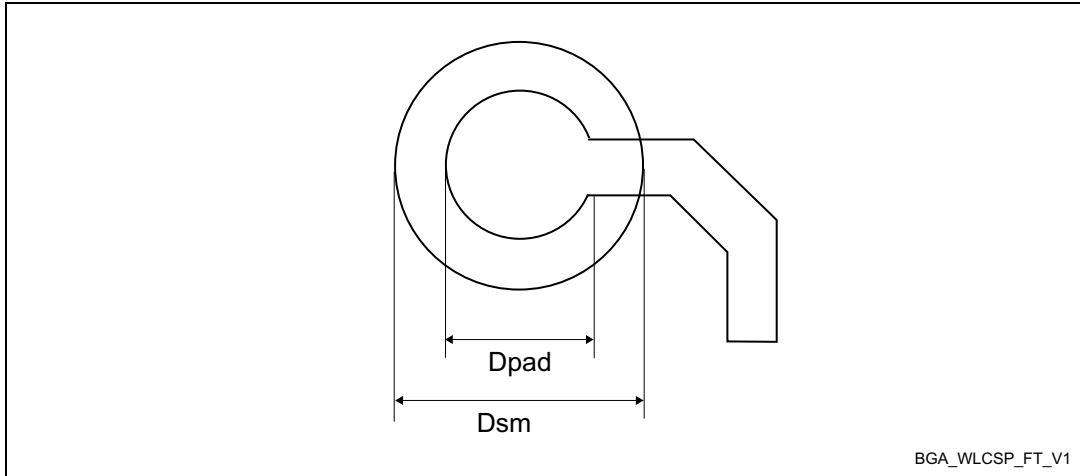

Table 92. UFBGA64 - Example of PCB design rules (0.5 mm pitch BGA)

Dimension	Values
Pitch	0.5 mm
Dpad	0.280 mm
Dsm	0.370 mm typ. (depends on the soldermask registration tolerance)
Stencil opening	0.280 mm
Stencil thickness	Between 0.100 mm and 0.125 mm
Pad trace width	0.100 mm

Table 93. LQFP80 - Mechanical data

Dim.	mm			inches ⁽¹⁴⁾		
	Min	Typ	Max	Min	Typ	Max
A	-	-	1.60	-	-	0.0630
A1 ⁽¹²⁾	0.05	-	0.15	0.0020	-	0.0059
A2	1.35	1.40	1.45	0.0531	0.0551	0.0571
b ⁽⁹⁾⁽¹¹⁾	0.17	0.22	0.27	0.0067	0.0087	0.0106
b1 ⁽¹¹⁾	0.17	0.20	0.23	0.0067	0.0078	0.0090
c ⁽¹¹⁾	0.09	-	0.20	0.0038	-	0.0067
c1 ⁽¹¹⁾	0.09	-	0.16	0.0038	-	0.0063
D	14.00 BSC			0.5512 BSC		
D1	12.00 BSC			0.4724 BSC		
E	14.00 BSC			0.5512 BSC		
E1	12.00 BSC			0.4724 BSC		
e	0.50 BSC			0.0197 BSC		
L	0.45	0.60	0.75	0.0177	0.0236	0.0295
L1	1.00 REF			0.0394 REF		
N ⁽¹³⁾	80					
θ	0°	3.5°	7°	0°	3.5°	7°
θ1	0°	-	-	0°	-	-
θ2	10°	12°	14°	10°	12°	14°
θ3	10°	12°	14°	10°	12°	14°
R1	0.08	-	-	0.0031	-	-
R2	0.08	-	0.20	0.0031	-	0.0079
S	0.20	-	-	0.0079	-	-
aaa ⁽¹⁾	0.20			0.0079		
bbb ⁽¹⁾	0.20			0.0079		
ccc ⁽¹⁾	0.08			0.0031		
ddd ⁽¹⁾	0.08			0.0031		

Notes:

1. Dimensioning and tolerancing schemes conform to ASME Y14.5M-1994.
2. The Top package body size may be smaller than the bottom package size by as much as 0.15 mm.
3. Datums A-B and D to be determined at datum plane H.
4. To be determined at seating datum plane C.
5. Dimensions D1 and E1 do not include mold flash or protrusions. Allowable mold flash or protrusions is "0.25 mm" per side. D1 and E1 are Maximum plastic body size dimensions including mold mismatch.
6. Details of pin 1 identifier are optional but must be located within the zone indicated.
7. All Dimensions are in millimeters.
8. No intrusion allowed inwards the leads.
9. Dimension "b" does not include dambar protrusion. Allowable dambar protrusion shall not cause the lead width to exceed the maximum "b" dimension by more than 0.08 mm. Dambar cannot be located on the lower radius or the foot. Minimum space between protrusion and an adjacent lead is 0.07 mm for 0.4 mm and 0.5 mm pitch packages.
10. Exact shape of each corner is optional.
11. These dimensions apply to the flat section of the lead between 0.10 mm and 0.25 mm from the lead tip.
12. A1 is defined as the distance from the seating plane to the lowest point on the package body.
13. "N" is the number of terminal positions for the specified body size.
14. Values in inches are converted from mm and rounded to 4 decimal digits.
15. Drawing is not to scale.

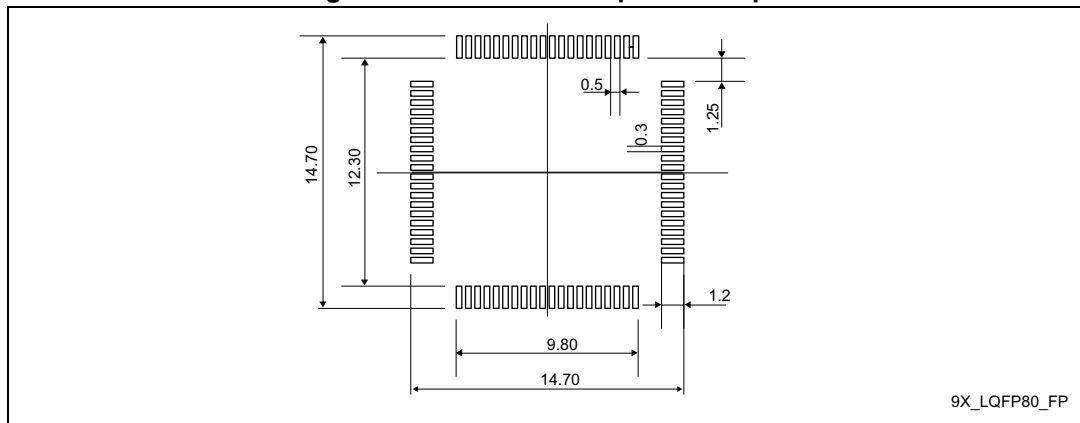
Figure 54. LQFP80 - Footprint example

1. Dimensions are expressed in millimeters.

6.10 LQFP100 package information (1L)

This LQFP is a 100-pin, 14 x 14 mm low-profile quad flat package.

Note: See list of notes in the notes section.

Figure 55. LQFP100 - Outline⁽¹⁵⁾

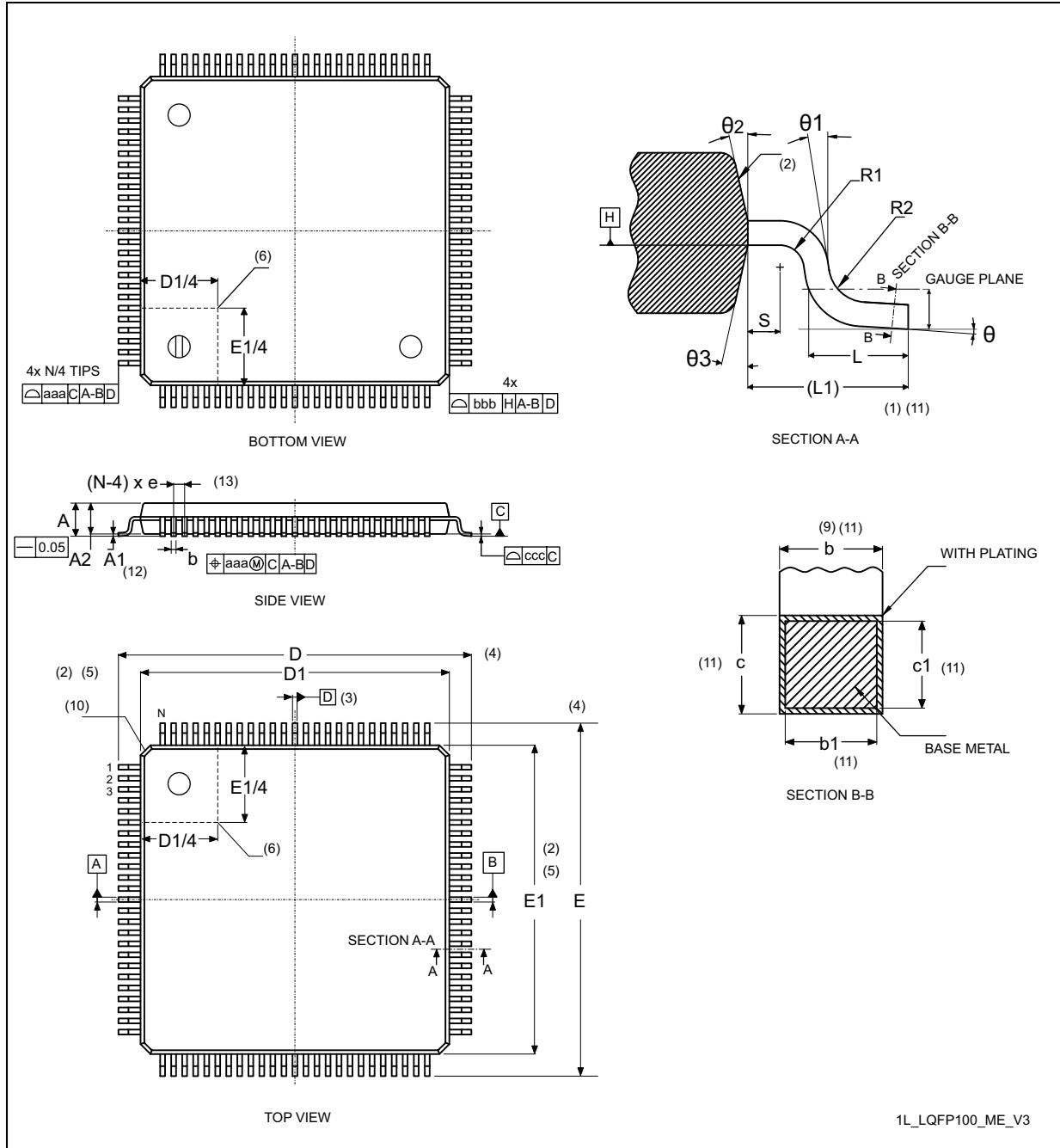

Table 94. LQFP100 - Mechanical data

Symbol	millimeters			inches ⁽¹⁴⁾		
	Min	Typ	Max	Min	Typ	Max
A	-	1.50	1.60	-	0.0590	0.0630
A1 ⁽¹²⁾	0.05	-	0.15	0.0019	-	0.0059
A2	1.35	1.40	1.45	0.0531	0.0551	0.0570
b ⁽⁹⁾⁽¹¹⁾	0.17	0.22	0.27	0.0067	0.0087	0.0106
b1 ⁽¹¹⁾	0.17	0.20	0.23	0.0067	0.0079	0.0090
c ⁽¹¹⁾	0.09	-	0.20	0.0035	-	0.0079
c1 ⁽¹¹⁾	0.09	-	0.16	0.0035	-	0.0063
D ⁽⁴⁾	16.00 BSC			0.6299 BSC		
D1 ⁽²⁾⁽⁵⁾	14.00 BSC			0.5512 BSC		
E ⁽⁴⁾	16.00 BSC			0.6299 BSC		
E1 ⁽²⁾⁽⁵⁾	14.00 BSC			0.5512 BSC		
e	0.50 BSC			0.0197 BSC		
L	0.45	0.60	0.75	0.177	0.0236	0.0295
L1 ⁽¹⁾⁽¹¹⁾	1.00			-	0.0394	-
N ⁽¹³⁾	100					
θ	0°	3.5°	7°	0°	3.5°	7°
θ1	0°	-	-	0°	-	-
θ2	10°	12°	14°	10°	12°	14°
θ3	10°	12°	14°	10°	12°	14°
R1	0.08	-	-	0.0031	-	-
R2	0.08	-	0.20	0.0031	-	0.0079
S	0.20	-	-	0.0079	-	-
aaa ⁽¹⁾	0.20			0.0079		
bbb ⁽¹⁾	0.20			0.0079		
ccc ⁽¹⁾	0.08			0.0031		
ddd ⁽¹⁾	0.08			0.0031		

Notes:

1. Dimensioning and tolerancing schemes conform to ASME Y14.5M-1994.
2. The top package body size may be smaller than the bottom package size by as much as 0.15 mm.
3. Datums A-B and D to be determined at datum plane H.
4. To be determined at the seating datum plane C.
5. Dimensions D1 and E1 do not include mold flash or protrusions. Allowable mold flash or protrusions is 0.25 mm per side. D1 and E1 are maximum plastic body size dimensions including mold mismatch.
6. Details of pin 1 identifier are optional but must be located within the zone indicated.
7. All dimensions are in millimeters.
8. No intrusion is allowed inwards the leads.
9. Dimension b does not include a dambar protrusion. Allowable dambar protrusion shall not cause the lead width to exceed the maximum b dimension by more than 0.08 mm. The dambar cannot be located on the lower radius or the foot. The minimum space between the protrusion and an adjacent lead is 0.07 mm for 0.4 mm and 0.5 mm pitch packages.
10. The exact shape of each corner is optional.
11. These dimensions apply to the flat section of the lead that is between 0.10 mm and 0.25 mm from the lead tip.
12. A1 is defined as the distance from the seating plane to the lowest point on the package body.
13. N is the number of terminal positions for the specified body size.
14. Values in inches are converted from mm and rounded to four decimal digits.
15. Drawing is not to scale.

Figure 56. LQFP100 - Footprint example

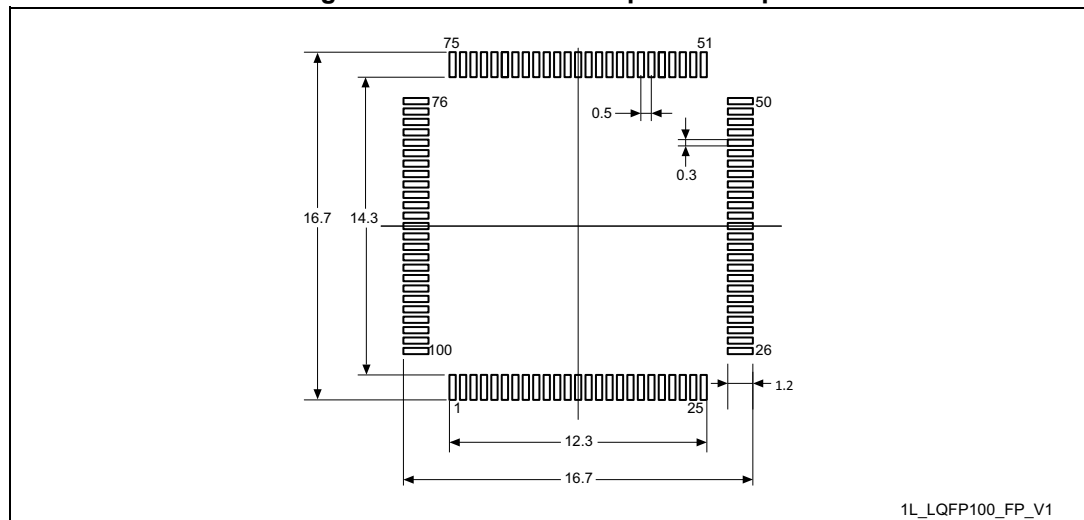

1. Dimensions are expressed in millimeters.

6.11 UFBGA100 package information (A0C2)

This UFBGA is a 100-ball, 7 x 7 mm, 0.50 mm pitch, ultra fine pitch ball grid array package.

Note: See list of notes in the notes section.

Figure 57. UFBGA100 - Outline⁽¹³⁾

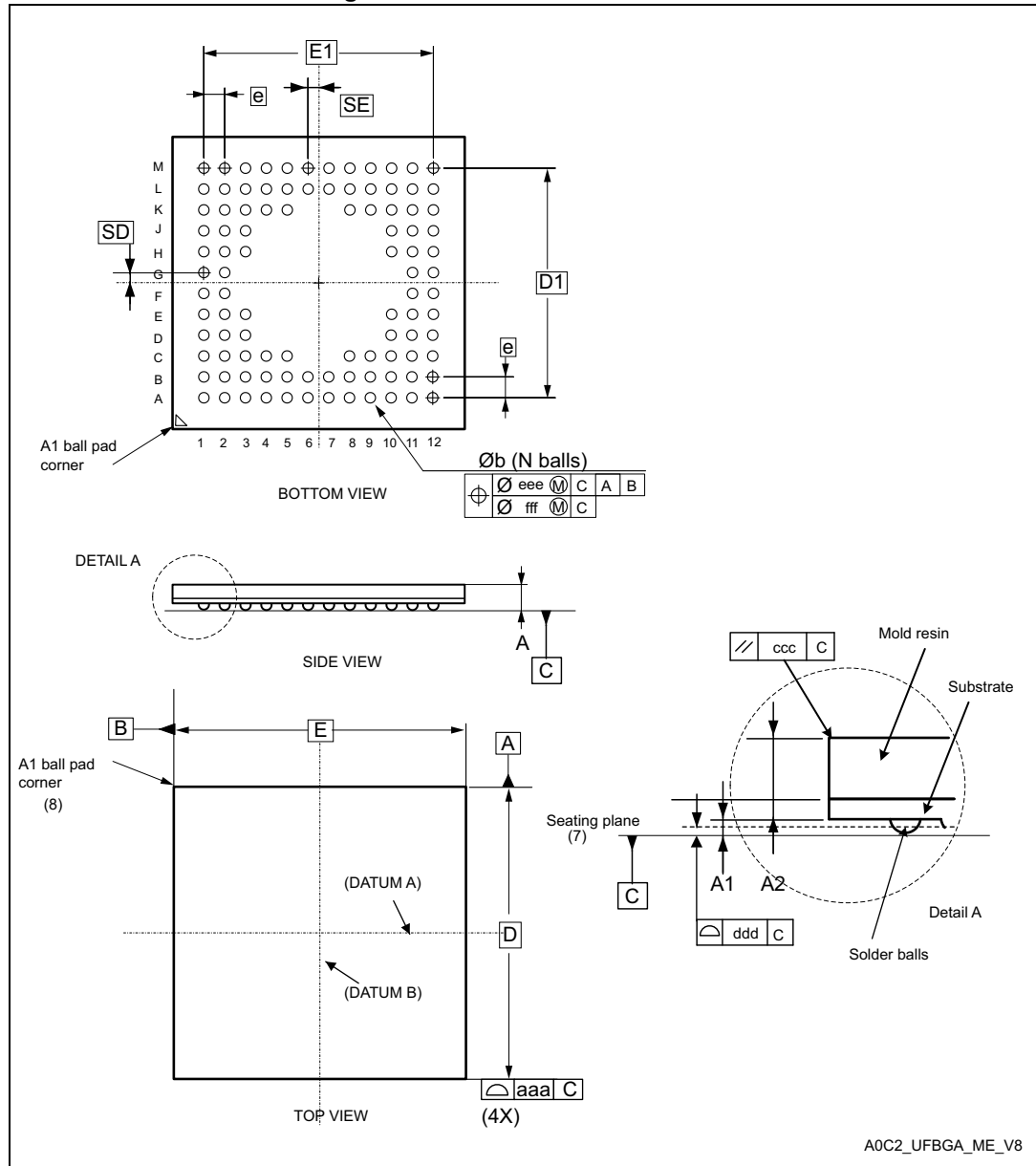

Table 95. UFBGA100 - Mechanical data

Symbol	millimeters ⁽¹⁾			inches ⁽¹²⁾		
	Min.	Typ.	Max.	Min.	Typ.	Max.
A ⁽²⁾⁽³⁾	-	-	0.60	-	-	0.0236
A1 ⁽⁴⁾	0.05	-	-	0.0020	-	-
A2	-	0.43	-	-	0.0169	-
b ⁽⁵⁾	0.23	0.28	0.33	0.0090	0.0110	0.0130
D ⁽⁶⁾	7.00 BSC			0.2756 BSC		
D1	5.50 BSC			0.2165 BSC		
E	7.00 BSC			0.2756 BSC		
E1	5.50 BSC			0.2165 BSC		
e ⁽⁹⁾	0.50 BSC			0.0197 BSC		
N ⁽¹⁰⁾	100					
SD ⁽¹¹⁾	0.25 BSC			0.0098 BSC		
SE ⁽¹¹⁾	0.25 BSC			0.0098 BSC		
aaa	0.15			0.0059		
ccc	0.20			0.0079		
ddd	0.08			0.0031		
eee	0.15			0.0059		
fff	0.05			0.0020		

Notes:

1. Dimensioning and tolerancing schemes conform to ASME Y14.5M-2009 apart European projection.
2. UFBGA stands for ultra profile fine pitch ball grid array: 0.50 mm < A ≤ 0.65 mm / fine pitch e < 1.00 mm.
3. The profile height, A, is the distance from the seating plane to the highest point on the package. It is measured perpendicular to the seating plane.
4. A1 is defined as the distance from the seating plane to the lowest point on the package body.
5. Dimension b is measured at the maximum diameter of the terminal (ball) in a plane parallel to primary datum C.
6. BSC stands for BASIC dimensions. It corresponds to the nominal value and has no tolerance. For tolerances refer to form and position table. On the drawing these dimensions are framed.
7. Primary datum C is defined by the plane established by the contact points of three or more solder balls that support the device when it is placed on top of a planar surface.
8. The terminal (ball) A1 corner must be identified on the top surface of the package by using a corner chamfer, ink or metalized markings, or other feature of package body or

- integral heat slug. A distinguish feature is allowable on the bottom surface of the package to identify the terminal A1 corner. Exact shape of each corner is optional.
9. e represents the solder ball grid pitch.
 10. N represents the total number of balls on the BGA.
 11. Basic dimensions SD and SE are defined with respect to datums A and B. It defines the position of the centre ball(s) in the outer row or column of a fully populated matrix.
 12. Values in inches are converted from mm and rounded to 4 decimal digits.
 13. Drawing is not to scale.

Figure 58. UFBGA100 - Footprint example

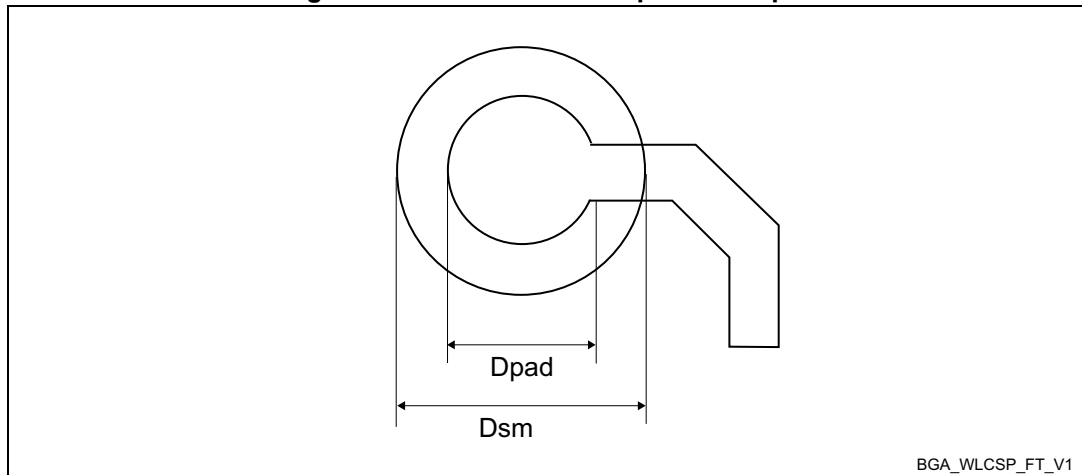

Table 96. UFBGA100 - Example of PCB design rules (0.5 mm pitch BGA)

Dimension	Values
Pitch	0.50 mm
Dpad	0.280 mm
Dsm	0.370 mm typ. (depends on the solder mask registration tolerance)
Stencil opening	0.280 mm
Stencil thickness	Between 0.100 mm and 0.125 mm

6.12 Thermal characteristics

The operating junction temperature T_J must never exceed the maximum given in [Table 24: General operating conditions](#).

The maximum junction temperature in °C that the device can reach if respecting the operating conditions, is:

$$T_J(\text{max}) = T_A(\text{max}) + P_D(\text{max}) \times \Theta_{JA}$$

where:

- $T_A(\text{max})$ is the maximum operating ambient temperature in °C,
- Θ_{JA} is the package junction-to-ambient thermal resistance, in °C/W,
- $P_D = P_{INT} + P_{I/O}$.
 - P_{INT} is power dissipation contribution from product of I_{DD} and V_{DD}
 - $P_{I/O}$ is power dissipation contribution from output ports where:
 $P_{I/O} = \sum (V_{OL} \times I_{OL}) + \sum ((V_{DDIO1} - V_{OH}) \times I_{OH})$,
 taking into account the actual V_{OL} / I_{OL} and V_{OH} / I_{OH} of the I/Os at low and high level in the application.

Table 97. Package thermal characteristics

Symbol	Parameter	Package	Value	Unit
Θ_{JA}	Thermal resistance junction-ambient	LQFP32 7 × 7 mm	59	°C/W
		UFQFPN32 5 × 5 mm	35	
		LQFP48 7 × 7 mm	59	
		UFQFPN48 7 × 7 mm	28	
		WLCSP52 3.09 × 3.15 mm	55	
		LQFP64 10 × 10 mm	53	
		UFBGA64 5 × 5 mm	51	
		LQFP80 12 × 12 mm	51	
		LQFP100 14 × 14 mm	47	
		UFBGA100 7 × 7 mm	48	

Table 97. Package thermal characteristics (continued)

Symbol	Parameter	Package	Value	Unit
Θ_{JB}	Thermal resistance junction-board	LQFP32 7 × 7 mm	27	°C/W
		UFQFPN32 5 × 5 mm	20	
		LQFP48 7 × 7 mm	27	
		UFQFPN48 7 × 7 mm	12	
		WLCSP52 3.09 × 3.15 mm	23	
		LQFP64 10 × 10 mm	25	
		UFBGA64 5 × 5 mm	32	
		LQFP80 12 × 12 mm	24	
		LQFP100 14 × 14 mm	23	
		UFBGA100 7 × 7 mm	30	
Θ_{JC}	Thermal resistance junction-case	LQFP32 7 × 7 mm	13	°C/W
		UFQFPN32 5 × 5 mm	14	
		LQFP48 7 × 7 mm	13	
		UFQFPN48 7 × 7 mm	9	
		WLCSP52 3.09 × 3.15 mm	3	
		LQFP64 10 × 10 mm	11	
		UFBGA64 5 × 5 mm	32	
		LQFP80 12 × 12 mm	10	
		LQFP100 14 × 14 mm	9	
		UFBGA100 7 × 7 mm	12	

6.12.1 Reference document

JESD51-2 Integrated Circuits Thermal Test Method Environment Conditions - Natural Convection (still air). Available from www.jedec.org.

6.12.2 Selecting the product temperature range

The temperature range is specified in the ordering information scheme shown in [Section 7: Ordering information](#).

Each temperature range suffix corresponds to a specific guaranteed ambient temperature at maximum dissipation and to a specific maximum junction temperature.

As applications do not commonly use microcontrollers at their maximum power consumption, it is useful to calculate the exact power consumption and junction temperature to determine which temperature range best suits the application.



The following example shows how to calculate the temperature range needed for a given application.

Example:

Assuming the following worst application conditions:

- ambient temperature $T_A = 50\text{ °C}$ (measured according to JESD51-2)
- $I_{DD} = 50\text{ mA}$; $V_{DD} = 3.6\text{ V}$
- 20 I/Os simultaneously used as output at low level with $I_{OL} = 8\text{ mA}$ ($V_{OL} = 0.4\text{ V}$), and
- 8 I/Os simultaneously used as output at low level with $I_{OL} = 20\text{ mA}$ ($V_{OL} = 1.3\text{ V}$),

the power consumption from power supply P_{INT} is:

$$P_{INT} = 50\text{ mA} \times 3.6\text{ V} = 180\text{ mW},$$

the power loss through I/Os P_{IO} is

$$P_{IO} = 20 \times 8\text{ mA} \times 0.4\text{ V} + 8 \times 20\text{ mA} \times 1.3\text{ V} = 272\text{ mW},$$

and the total power P_D to dissipate is:

$$P_D = 180\text{ mW} + 272\text{ mW} = 452\text{ mW}$$

For a package with $\Theta_{JA} = 65\text{ °C/W}$, the junction temperature stabilizes at:

$$T_J = 50\text{ °C} + (65\text{ °C/W} \times 452\text{ mW}) = 50\text{ °C} + 29.4\text{ °C} = 79.4\text{ °C}$$

As a conclusion, product version with suffix 6 (maximum allowed $T_J = 105\text{ °C}$) is sufficient for this application.

If the same application was used in a hot environment with maximum T_A greater than 75.5 °C , the junction temperature would exceed 105 °C and the product version allowing higher maximum T_J would have to be ordered.

7 Ordering information

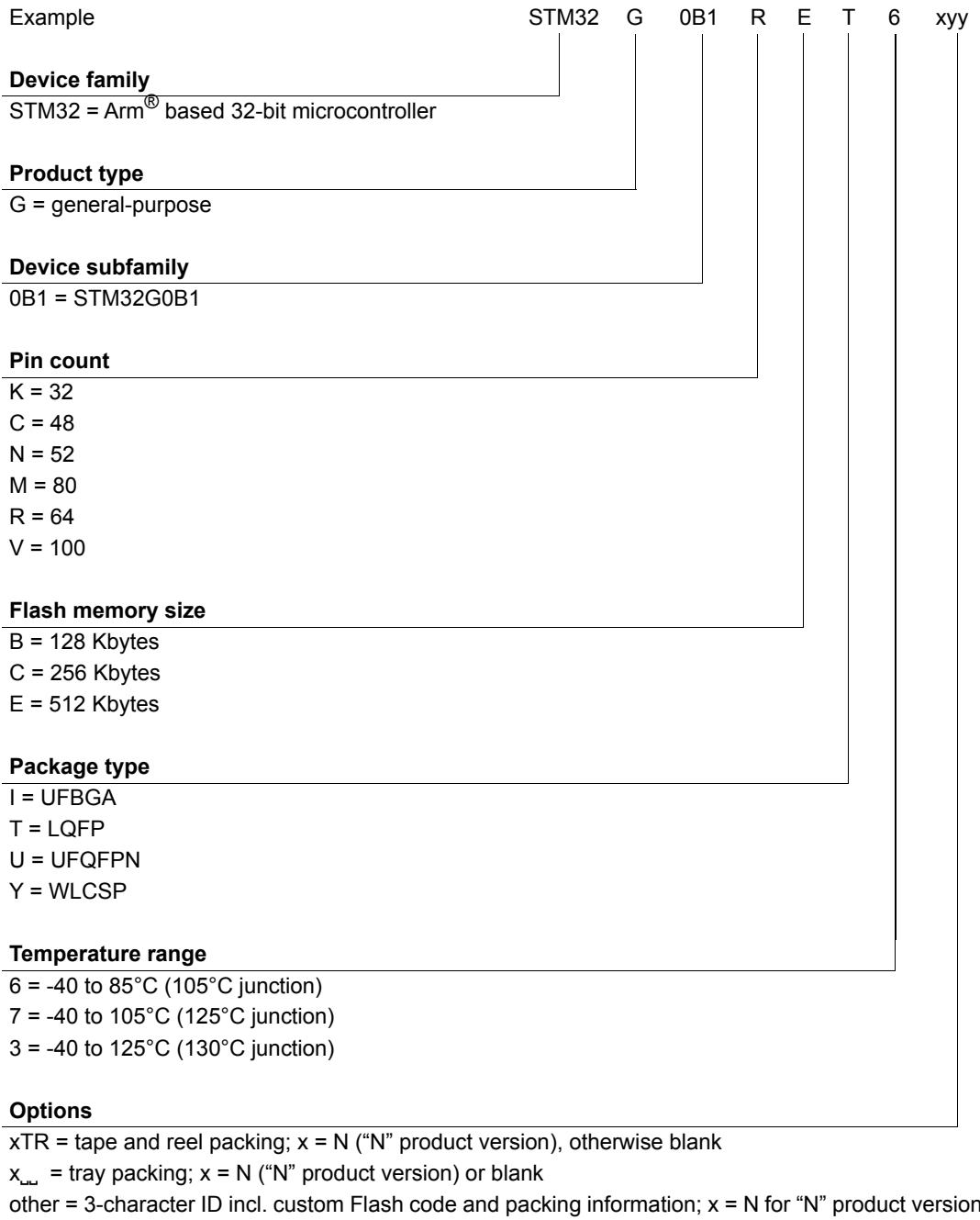

For a list of available options (memory, package, and so on) or for further information on any aspect of this device, contact your nearest ST sales office.



8 Important security notice

The STMicroelectronics group of companies (ST) places a high value on product security, which is why the ST product(s) identified in this documentation may be certified by various security certification bodies and/or may implement our own security measures as set forth herein. However, no level of security certification and/or built-in security measures can guarantee that ST products are resistant to all forms of attacks. As such, it is the responsibility of each of ST's customers to determine if the level of security provided in an ST product meets the customer needs both in relation to the ST product alone, as well as when combined with other components and/or software for the customer end product or application. In particular, take note that:

- ST products may have been certified by one or more security certification bodies, such as Platform Security Architecture (www.psacertified.org) and/or Security Evaluation standard for IoT Platforms (www.trustcb.com). For details concerning whether the ST product(s) referenced herein have received security certification along with the level and current status of such certification, either visit the relevant certification standards website or go to the relevant product page on www.st.com for the most up to date information. As the status and/or level of security certification for an ST product can change from time to time, customers should re-check security certification status/level as needed. If an ST product is not shown to be certified under a particular security standard, customers should not assume it is certified.
- Certification bodies have the right to evaluate, grant and revoke security certification in relation to ST products. These certification bodies are therefore independently responsible for granting or revoking security certification for an ST product, and ST does not take any responsibility for mistakes, evaluations, assessments, testing, or other activity carried out by the certification body with respect to any ST product.
- Industry-based cryptographic algorithms (such as AES, DES, or MD5) and other open standard technologies which may be used in conjunction with an ST product are based on standards which were not developed by ST. ST does not take responsibility for any flaws in such cryptographic algorithms or open technologies or for any methods which have been or may be developed to bypass, decrypt or crack such algorithms or technologies.
- While robust security testing may be done, no level of certification can absolutely guarantee protections against all attacks, including, for example, against advanced attacks which have not been tested for, against new or unidentified forms of attack, or against any form of attack when using an ST product outside of its specification or intended use, or in conjunction with other components or software which are used by customer to create their end product or application. ST is not responsible for resistance against such attacks. As such, regardless of the incorporated security features and/or any information or support that may be provided by ST, each customer is solely responsible for determining if the level of attacks tested for meets their needs, both in relation to the ST product alone and when incorporated into a customer end product or application.
- All security features of ST products (inclusive of any hardware, software, documentation, and the like), including but not limited to any enhanced security features added by ST, are provided on an "AS IS" BASIS. AS SUCH, TO THE EXTENT PERMITTED BY APPLICABLE LAW, ST DISCLAIMS ALL WARRANTIES, EXPRESS OR IMPLIED, INCLUDING BUT NOT LIMITED TO THE IMPLIED WARRANTIES OF MERCHANTABILITY OR FITNESS FOR A PARTICULAR PURPOSE, unless the applicable written and signed contract terms specifically provide otherwise.

9 Revision history

Table 98. Document revision history

Date	Revision	Changes
13-Nov-2020	1	Initial release.
30-Nov-2021	2	<p>Table 1: Device summary table reordered;</p> <p>Updated last paragraph in Section 2: Description;</p> <p>Updated Table 12: Pin assignment and description;</p> <p>Updated Table 68: VREFBUF characteristics;</p> <p>Missing package marking examples added in Section 6: Package information and Figure 42: LQFP32 package marking example corrected;</p> <p>Section : Device marking updated;</p> <p>Updated example in Section 6.12.2: Selecting the product temperature range;</p> <p>Section 6.12: Thermal characteristics - improved UFBGA100, UFBGA64, and LQFP80 Θ_{JA} values as a result of characterization;</p> <p>Updated Section 6.9: LQFP80 package information (9X).</p>
18-Jan-2022	3	<p>Updated Figure 11 to Figure 8 and Figure 5 to Figure 4: marking of VDDIO2-only supplied pins corrected.</p> <p>I/O type “_s” added to Table 11: Terms and symbols used in Pin assignment and description table and Table 12: Pin assignment and description.</p>
12-Dec-2022	4	<p>Added HSI48 in features on the cover page and in Figure 1: Block diagram;</p> <p>Updated Table 2: Features and peripheral counts;</p> <p>Updated Table 12: Pin assignment and description (UFBGA80 corrected to LQFP80) in the header;</p> <p>Updated Section : USB full speed (FS) characteristics;</p> <p>Section UCPD characteristics made a sub-section of Section 5.3.25: Characteristics of communication interfaces;</p> <p>Updated Figure 54: LQFP80 - Outline.</p>
21-Jun-2024	5	<p>Updated cover page figure with packages, Table 2: Features and peripheral counts, Section 1: Introduction, Section 3.5: Boot modes, Section 3.7.1: Power supply schemes, Section 3.7.4: Low-power modes, Section 3.14: Analog-to-digital converter (ADC), Section 3.18.1: Advanced-control timer (TIM1), Section 3.24: Universal serial bus full-speed host/device interface (USB) (title), Section 4: Pinouts, pin description and alternate functions (packages ordered from lowest to highest pin count, PF2-NRST I/O structure), table footnotes “Guaranteed by design” and “Guaranteed by characterization”, Figure 2, Figure 5 through Figure 18, Table 11: Terms and symbols used in Pin assignment and description table, Table 12: Pin assignment and description, Table 13: Port A alternate function mapping (AF0 to AF7), Figure 15: Power supply scheme, Table 22: Current characteristics, Table 24: General operating conditions, sections I/O static current consumption and I/O dynamic current consumption, Table 51: EMI characteristics, Figure 27: Recommended NRST pin protection, Figure 29: ADC typical connection diagram, Figure 31: SPI timing diagram - slave mode and CPHA = 0, Figure 32: SPI timing diagram - slave mode and CPHA = 1, Figure 33: SPI timing diagram - master mode, Table 55: I/O static characteristics, Table 57: Output voltage characteristics, section Output buffer timing characteristics (title), Table 58: Non-FT_c I/O output timing characteristics (footnote 1), Table 59: FT_c I/O output timing characteristics (footnote 1).</p>

Table 98. Document revision history (continued)

Date	Revision	Changes
21-Jun-2024	5	<p>Updated Table 62: Analog switch booster characteristics, Table 63: ADC characteristics (footnote 3, $W_{LATENCY}$), Table 65: ADC accuracy, Table 80: USB FS electrical characteristics, Table 81: UCPD operating conditions, and Section 6: Package information.</p> <p>Added Table 59: FT_c I/O output timing characteristics, Figure 36: USART timing diagram in SPI master mode, Figure 37: USART timing diagram in SPI slave mode, and section Section 8: Important security notice.</p>
17-Feb-2026	6	<p>Updated:</p> <p>Section 1: Introduction, Section 2: Description, Table 3: Access status versus readout protection level and execution modes, Table 7: Timer feature comparison, Figure 15: Power supply scheme, Table 21: Voltage characteristics, Table 22: Current characteristics, Table 63: ADC characteristics, Table 68: VREFBUF characteristics, Table 69: COMP characteristics, Figure 24: I/O input characteristics, Section 6.2: LQFP32 package information (5V), Section 6.3: UFQFPN32 package information (A0B8), Section 6.6: WLCSP52 package information (B0BG), Section 6.9: LQFP80 package information (9X), Section 6.10: LQFP100 package information (1L), Section 6.11: UFBGA100 package information (A0C2), Table 97: Package thermal characteristics.</p> <p>Added Section 5.3.16: Extended interrupt and event controller input (EXTI) characteristics.</p>

IMPORTANT NOTICE – READ CAREFULLY

STMicroelectronics NV and its subsidiaries (“ST”) reserve the right to make changes, corrections, enhancements, modifications, and improvements to ST products and/or to this document at any time without notice.

In the event of any conflict between the provisions of this document and the provisions of any contractual arrangement in force between the purchasers and ST, the provisions of such contractual arrangement shall prevail.

The purchasers should obtain the latest relevant information on ST products before placing orders. ST products are sold pursuant to ST’s terms and conditions of sale in place at the time of order acknowledgment.

The purchasers are solely responsible for the choice, selection, and use of ST products and ST assumes no liability for application assistance or the design of the purchasers’ products.

No license, express or implied, to any intellectual property right is granted by ST herein.

Resale of ST products with provisions different from the information set forth herein shall void any warranty granted by ST for such product.

If the purchasers identify an ST product that meets their functional and performance requirements but that is not designated for the purchasers’ market segment, the purchasers shall contact ST for more information.

ST and the ST logo are trademarks of ST. For additional information about ST trademarks, refer to www.st.com/trademarks. All other product or service names are the property of their respective owners.

Information in this document supersedes and replaces information previously supplied in any prior versions of this document.

© 2026 STMicroelectronics – All rights reserved

